



US00D451041B1

(12) **United States Design Patent**  
**Chen**

(10) **Patent No.:** **US D451,041 S**

(45) **Date of Patent:** **\*\* Nov. 27, 2001**

(54) **TAPE MEASURE**

(75) Inventor: **Jack Chen**, P.O. Box 176, Sparks, NV  
(US) 89432

(73) Assignee: **Jack Chen**, Sparks, NV (US)

(\*\*) Term: **14 Years**

(21) Appl. No.: **29/133,310**

(22) Filed: **Nov. 28, 2000**

(51) **LOC (7) Cl.** ..... **10-04**

(52) **U.S. Cl.** ..... **D10/74; D10/71; D10/72**

(58) **Field of Search** ..... **D10/71, 72, 74;**  
**33/483-494, 755-770**

(56) **References Cited**

**U.S. PATENT DOCUMENTS**

D. 318,435	*	7/1991	Cutler .....	D10/71
D. 339,536		9/1993	Ribron .	
D. 350,703		9/1994	Fifer .	
D. 421,230	*	2/2000	Gilliam et al. ....	D10/72
2,503,398	*	4/1950	Lindsey .....	33/494
2,634,919		4/1953	Strassler .	
3,672,597		6/1972	Williamson .	
3,913,232		10/1975	Marcell .	
4,215,829		8/1980	Boyllin .	
4,247,986	*	2/1981	Burroughs .....	D10/71
4,827,622		5/1989	Makar .	
4,965,944		10/1990	Kuze et al. .	
4,976,037		12/1990	Hines .	
5,079,851		1/1992	Sill .	

**FOREIGN PATENT DOCUMENTS**

848261 9/1952 (DE) .

\* cited by examiner

*Primary Examiner*—Antoine Duval Davis

(74) *Attorney, Agent, or Firm*—Bernhard Kreten

(57) **CLAIM**

The ornamental design for a tape measure, as shown and described.

**DESCRIPTION**

FIG. 1 is a perspective view from above of a tape measure showing my new design.

FIG. 2 is a fragmented top plan view of the tape measure showing only the first 2 and 1/3 foot section;

FIG. 3 is a fragmented top plan view of the tape measure showing only the second 2 and 1/3 foot section;

FIG. 4 is a fragmented top plan view of the tape measure showing only the fourth 2 and 1/3 foot section;

FIG. 5 is a fragmented top plan view of the tape measure showing only the fifth 2 and 1/3 foot section;

FIG. 6 is a fragmented top plan view of the tape measure showing only the sixth 2 and 1/3 foot section;

FIG. 7 is a fragmented top plan view of the tape measure showing only the seventh 2 and 1/3 foot section;

FIG. 8 is a fragmented top plan view of the tape measure showing only the eighth 2 and 1/3 foot section;

FIG. 9 is a fragmented top plan view of the tape measure showing only the ninth 2 and 1/3 foot section;

FIG. 10 is a fragmented top plan view of the tape measure showing only the tenth 2 and 1/3 foot section;

FIG. 11 is a fragmented top plan view of the tape measure showing only the eleventh 2 and 1/3 foot section; and,

FIG. 12 is a fragmented top plan view of the tape measure showing only the twelfth 2 and 1/3 foot section.

The broken-line showing of environmental structure in FIG. 1 is for illustrative purposes only and forms no part of the claimed design.

**1 Claim, 12 Drawing Sheets**

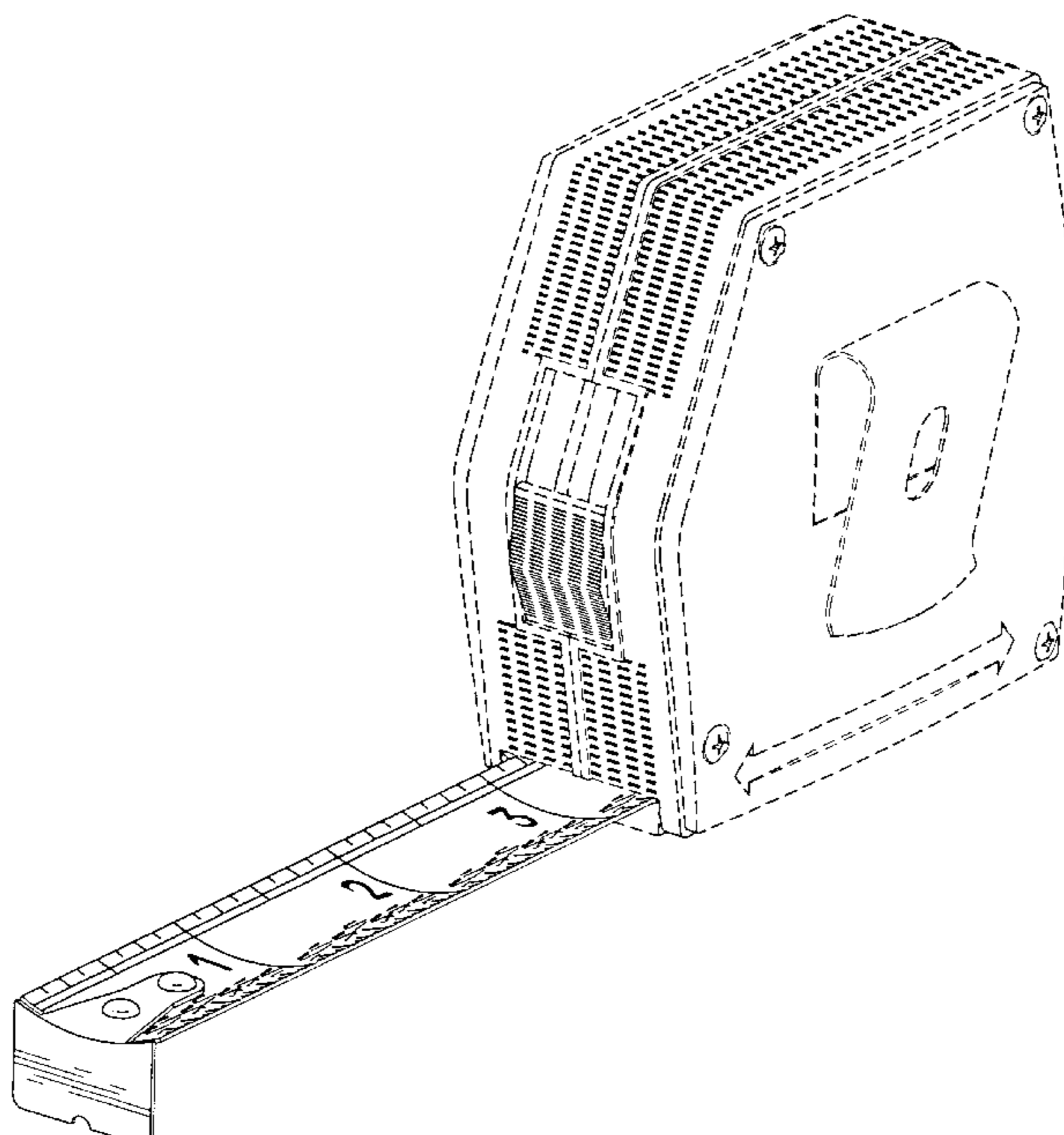

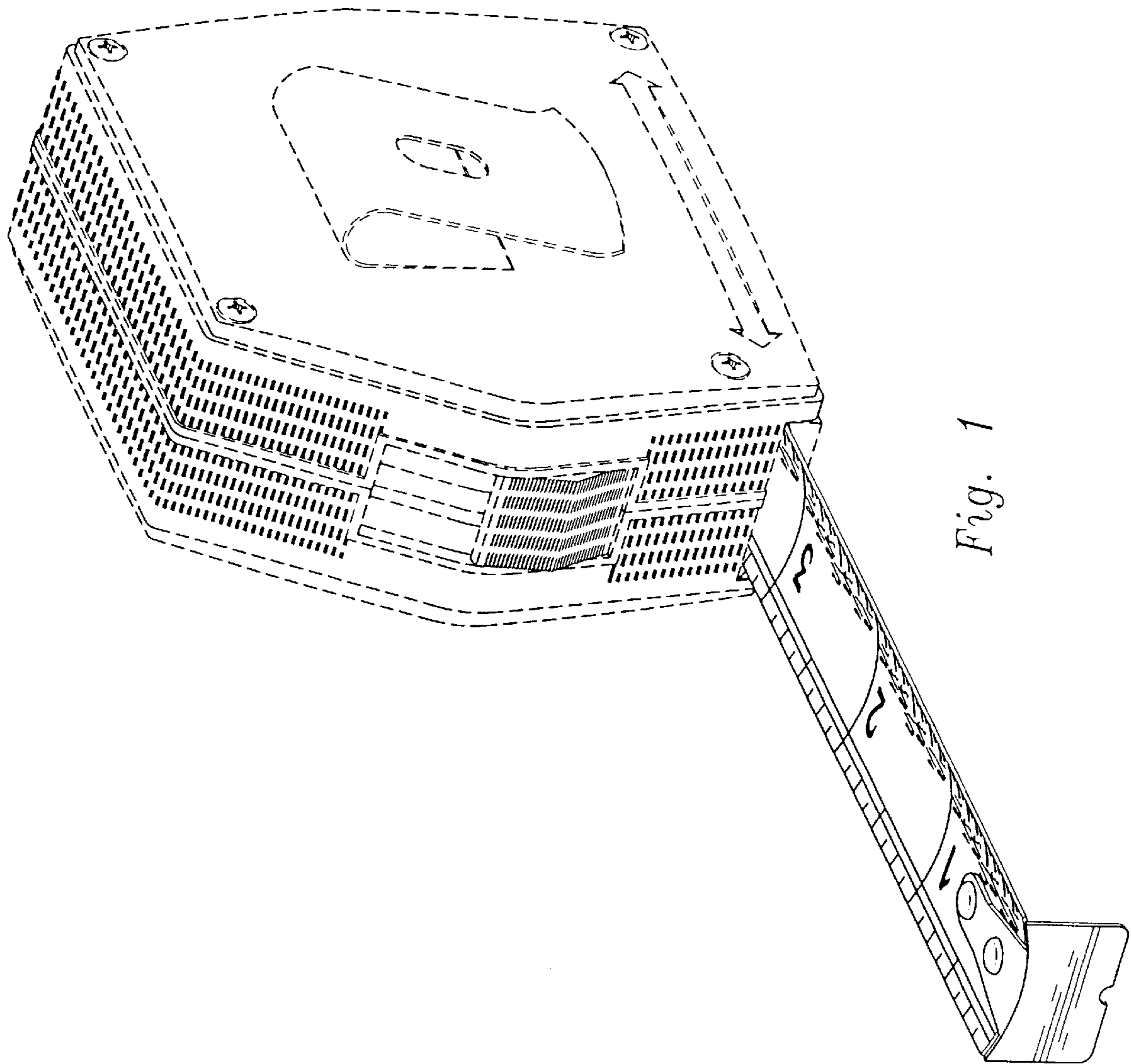

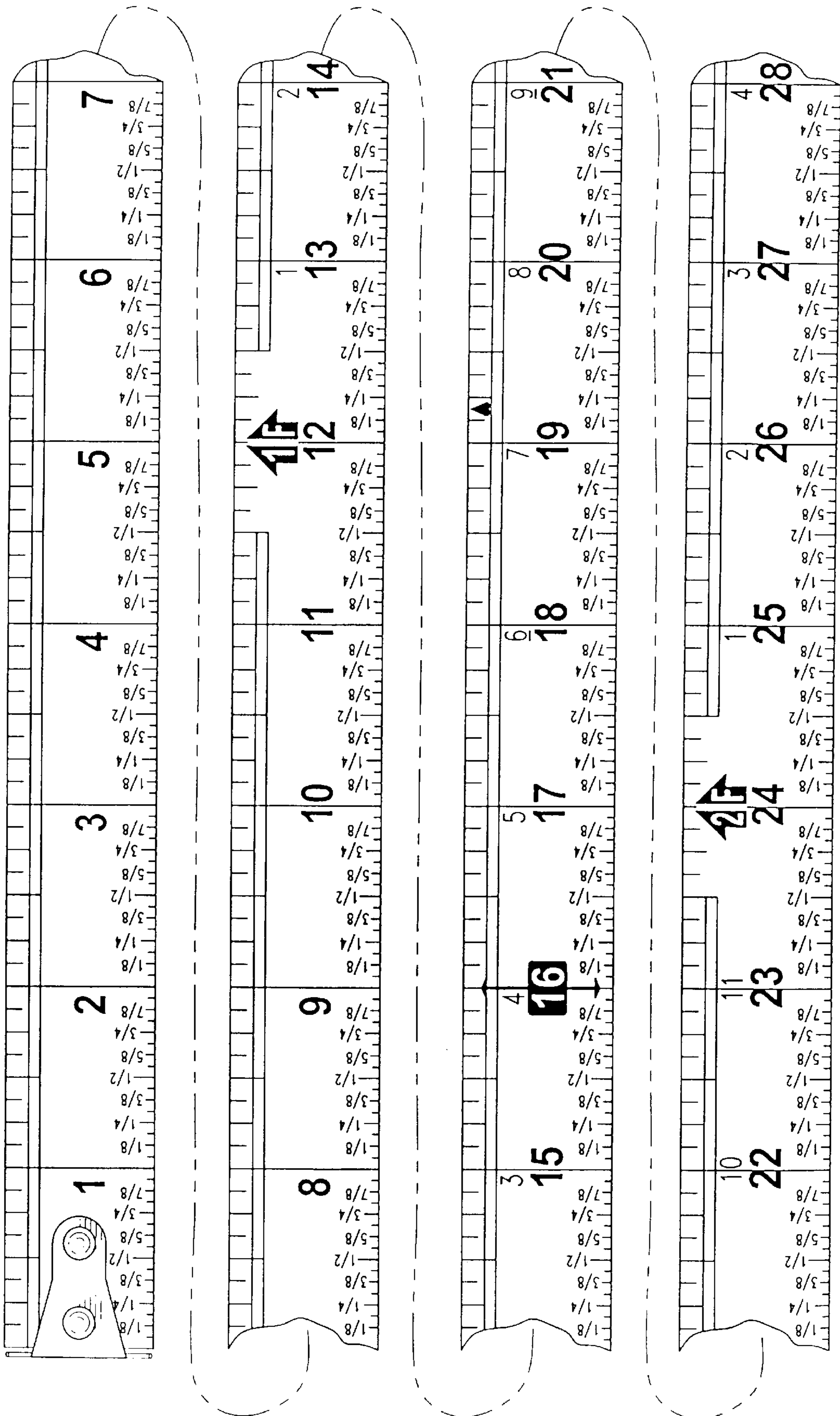

Fig. 2

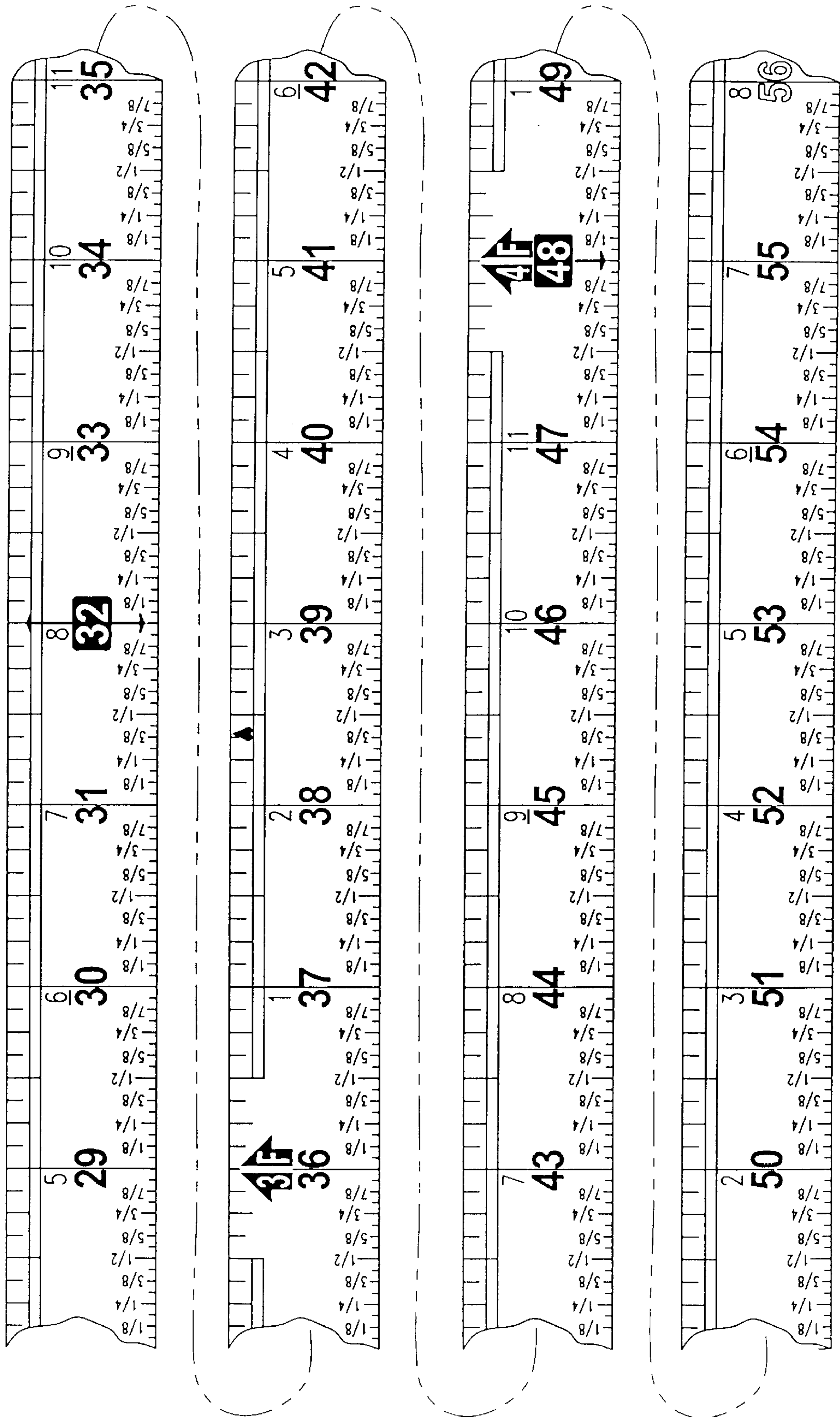

Fig. 3

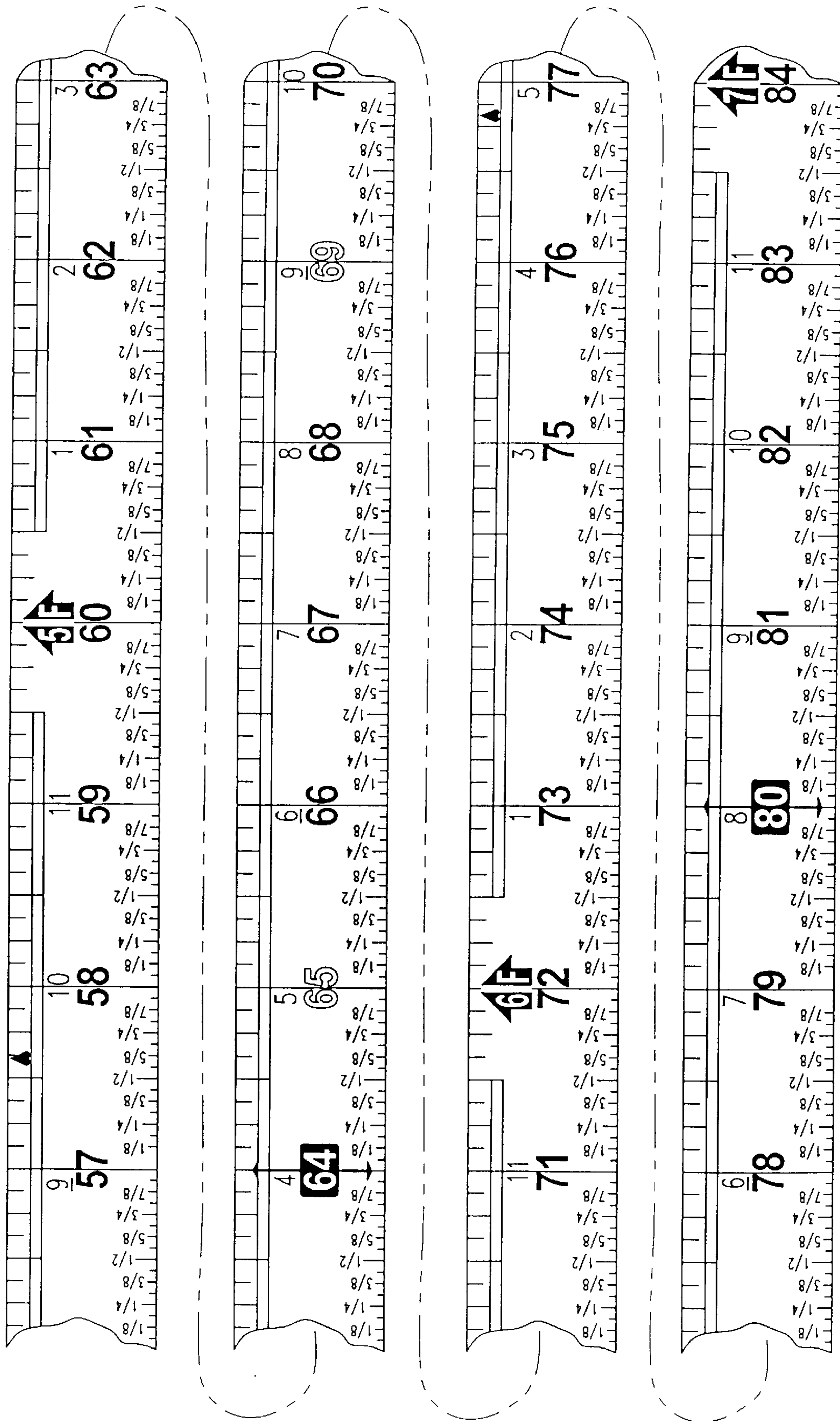

Fig. 4



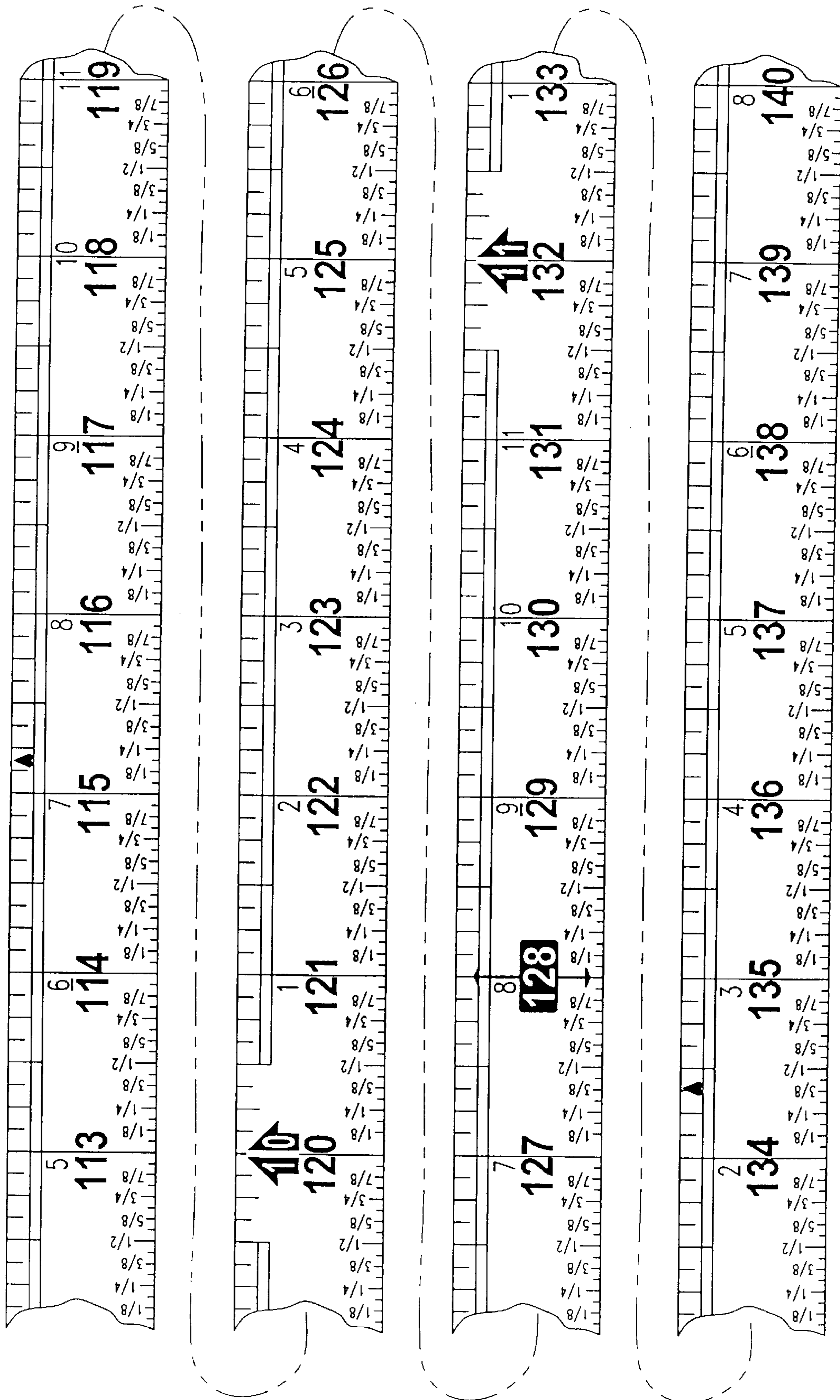

Fig. 6

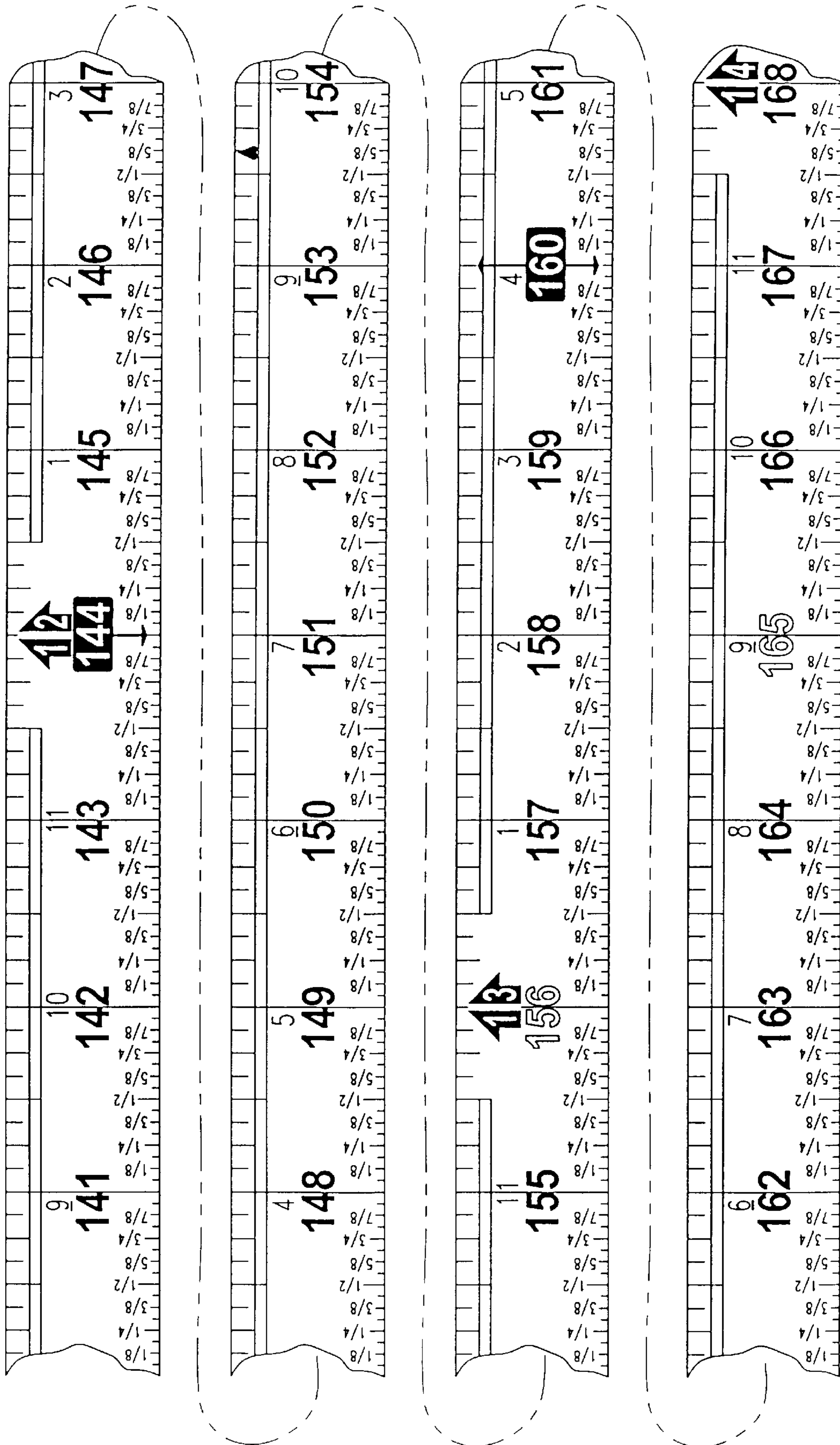

Fig. 7



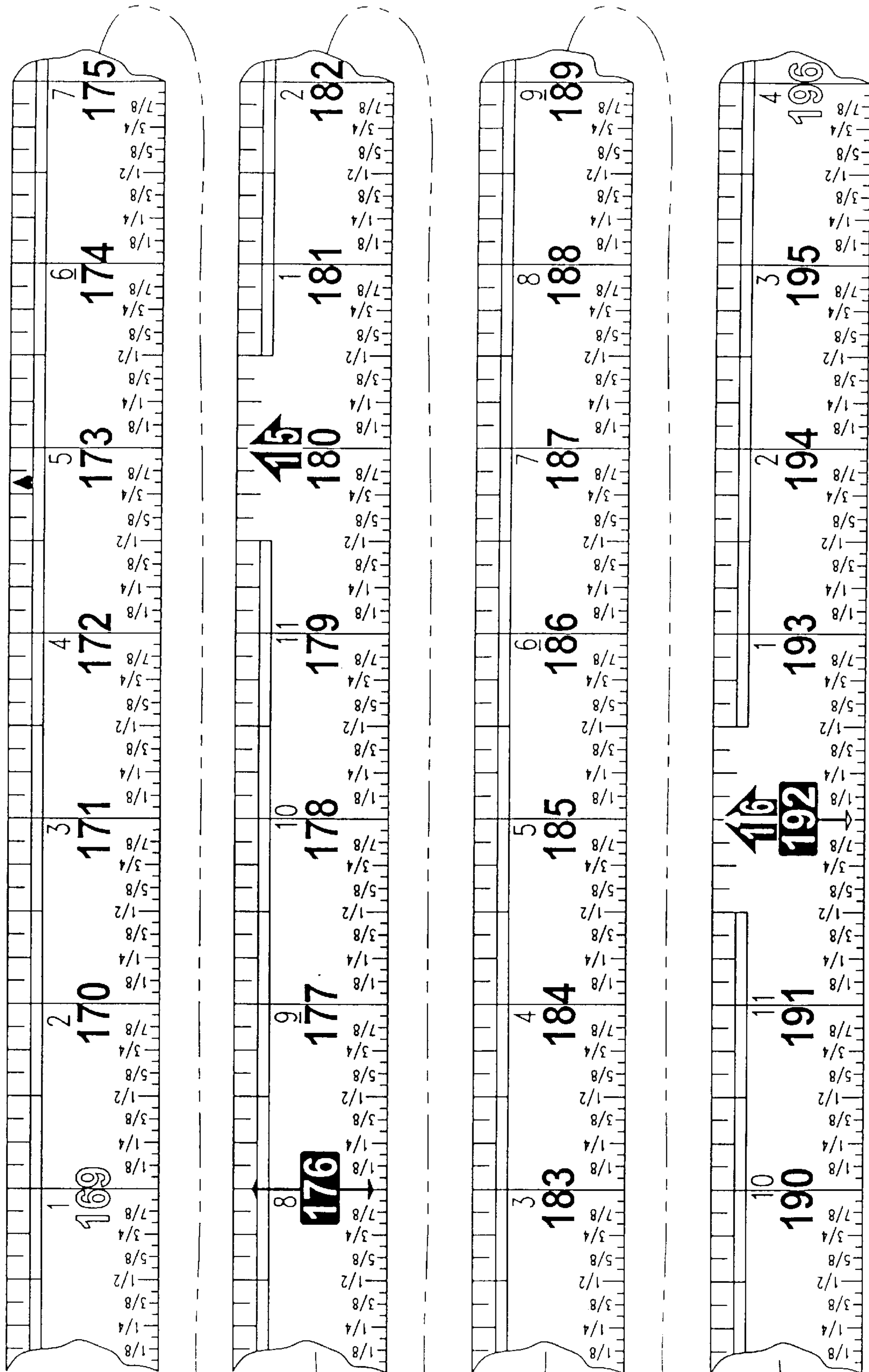

Fig. 8

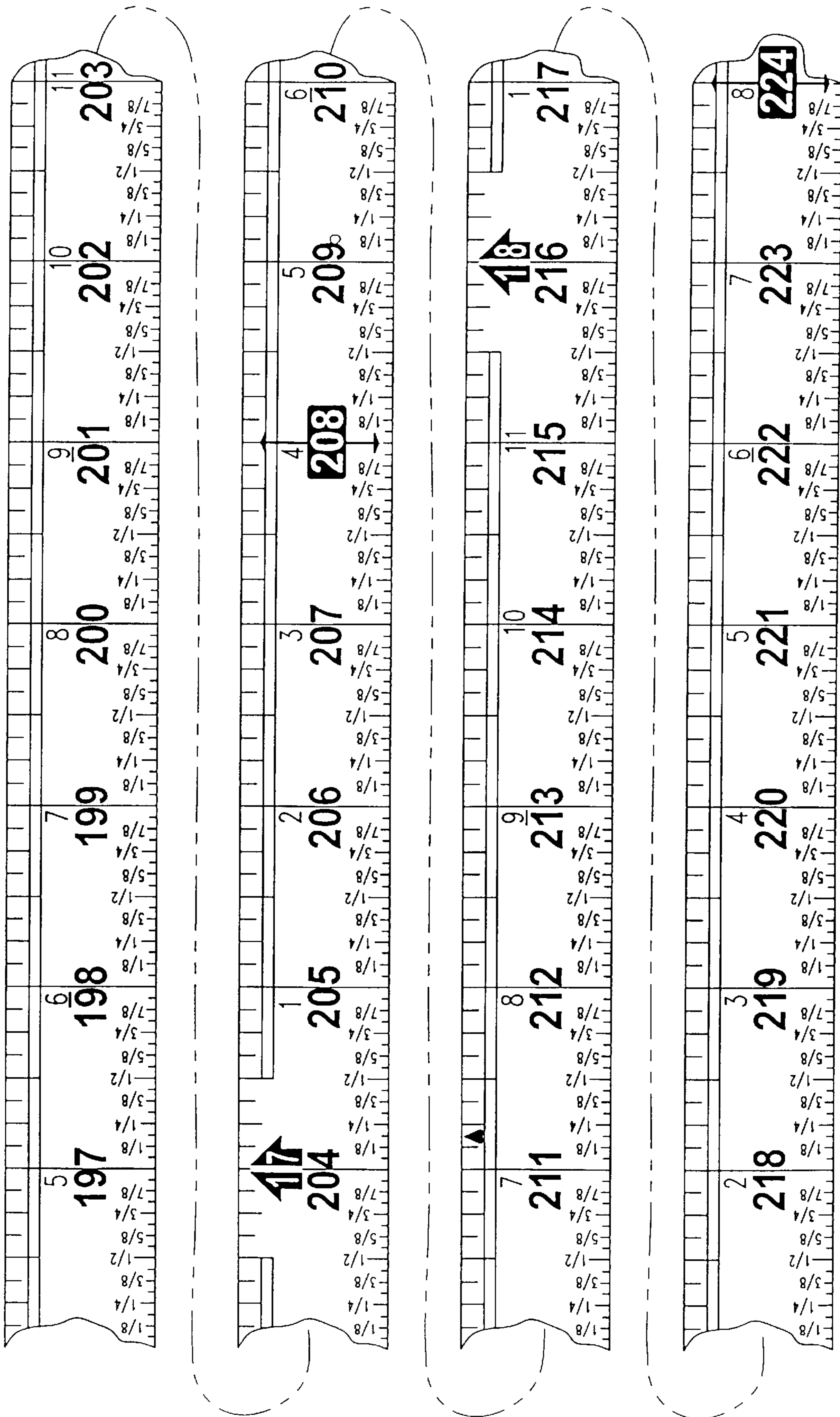

Fig. 9

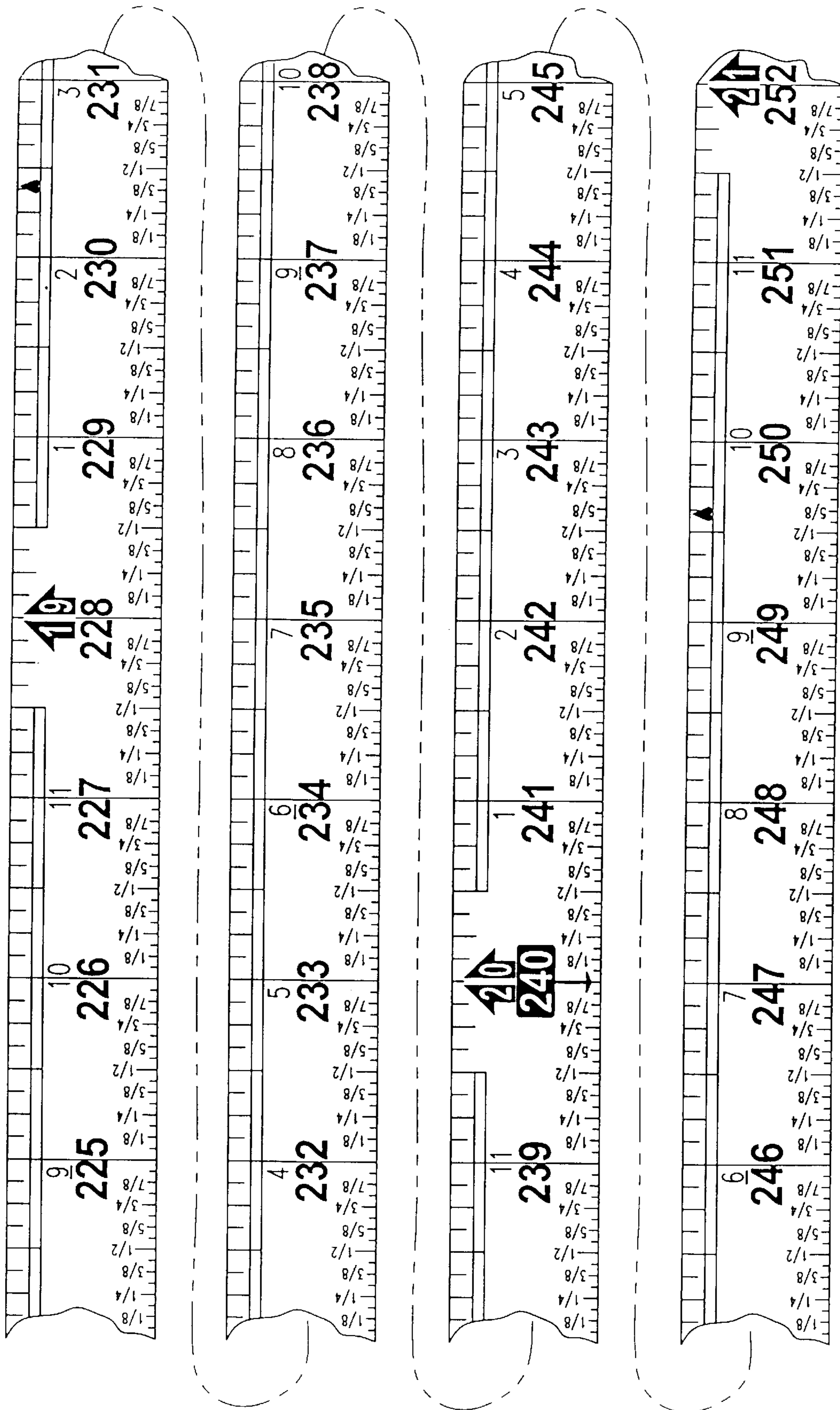

Fig. 10

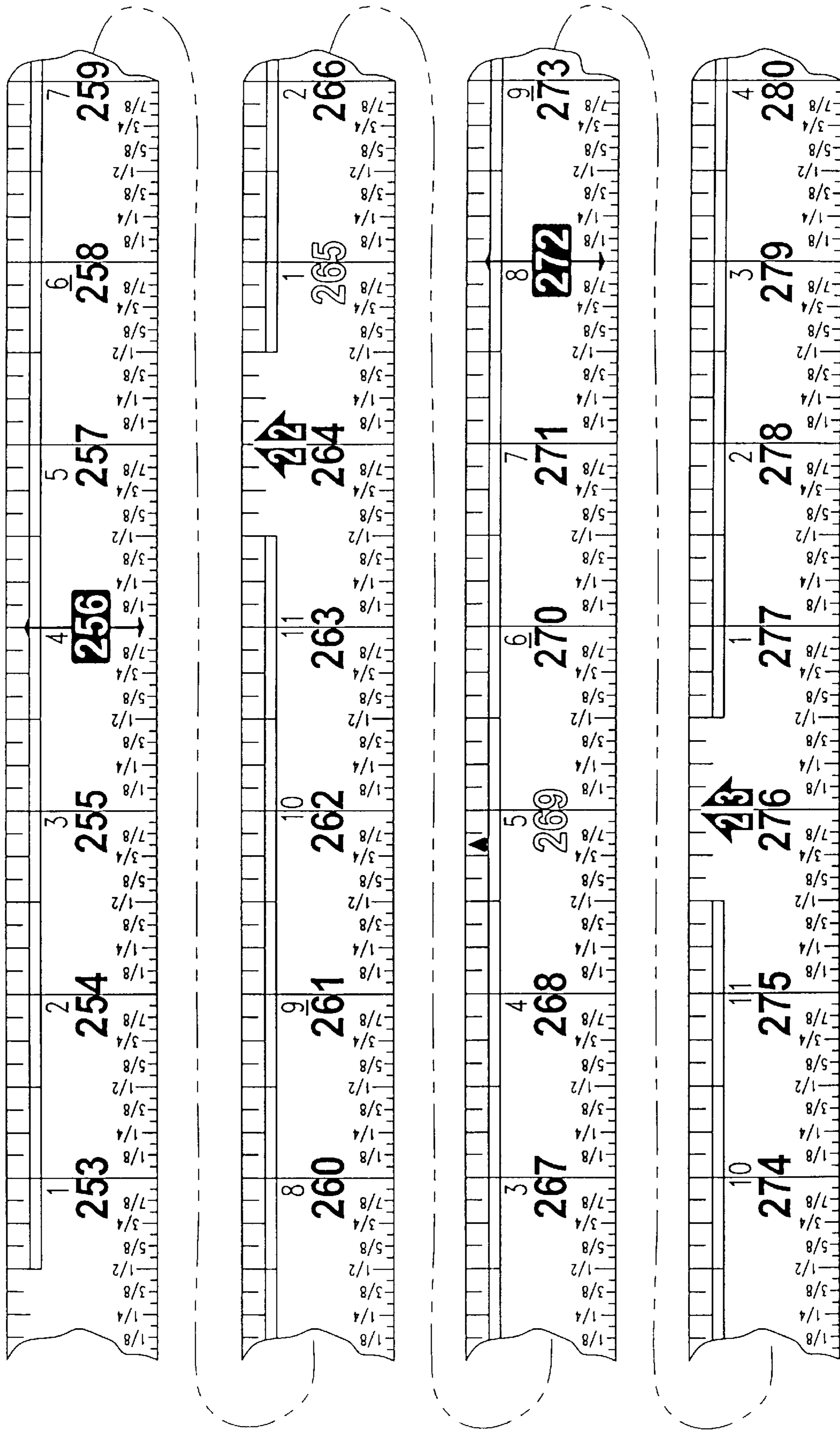

Fig. 11

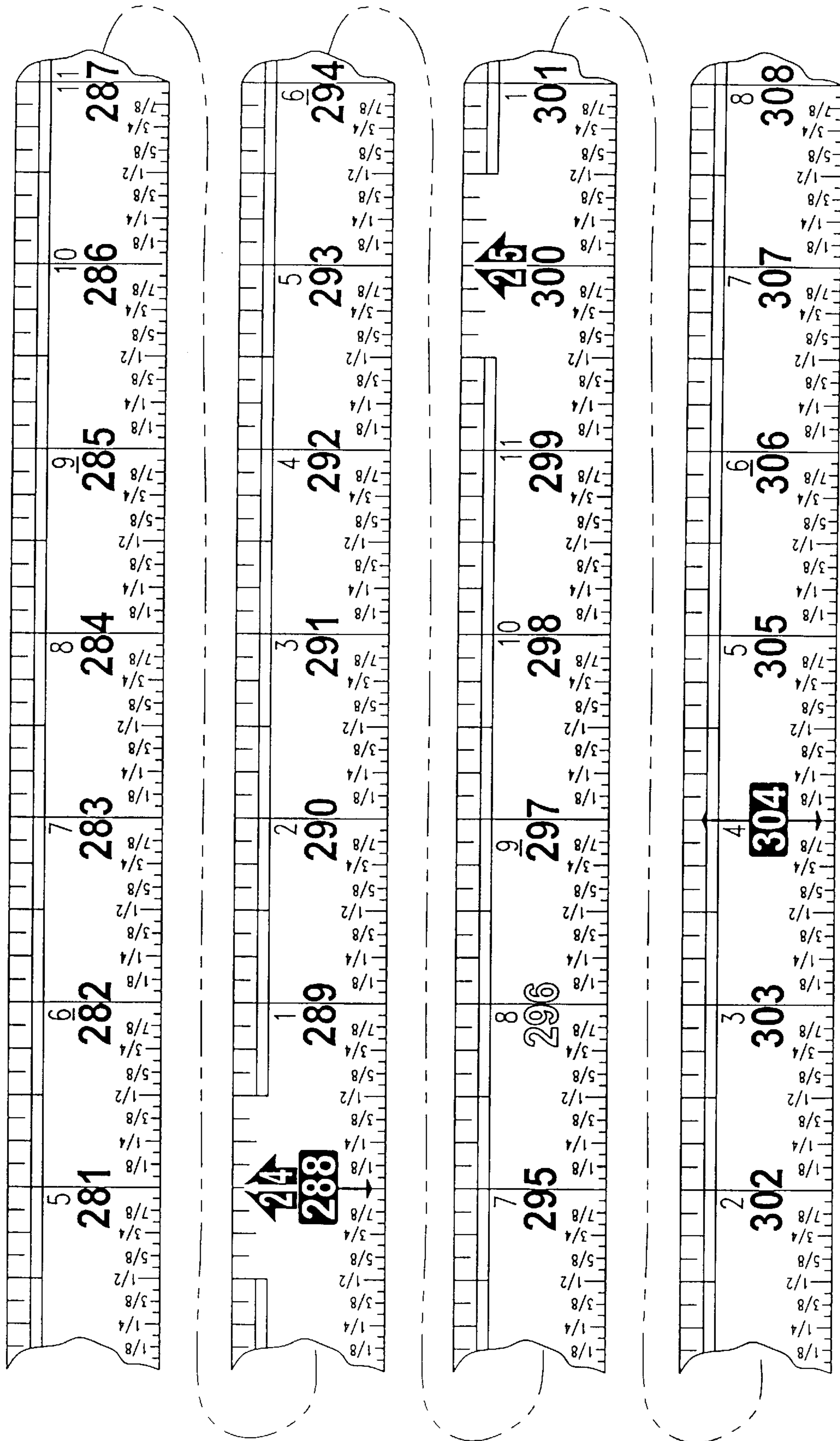

Fig. 12