



US00D450991B1

(12) **United States Design Patent**
Nardozza et al.

(10) **Patent No.:** **US D450,991 S**

(45) **Date of Patent:** **** Nov. 27, 2001**

(54) **CLAMP**

(76) Inventors: **John M. Nardozza**, 61 Town Farm Rd., Chester, NH (US) 03036; **Timothy T. Rockwell**, 175 Elm St., Andover, MA (US) 01810

(**) Term: **14 Years**

(21) Appl. No.: **29/125,399**

(22) Filed: **Jun. 22, 2000**

(51) **LOC (7) Cl.** **08-05**

(52) **U.S. Cl.** **D8/73**

(58) **Field of Search** D8/71-74; 81/249; 29/257

(56) **References Cited**

U.S. PATENT DOCUMENTS

24,194	5/1859	Clackson .	
D. 144,587	4/1946	Ross .	
D. 226,856	5/1973	Leto et al. .	
D. 297,402	8/1988	Williams	D8/73
D. 334,524	4/1993	Pinkney	D8/73
D. 340,632	10/1993	Easley	D8/74
D. 348,816	* 7/1994	Degen	D8/73
D. 358,538	* 5/1995	Cote	D8/73
2,167,897	* 8/1939	Kulp	D8/73
2,221,326	* 11/1940	Holman	269/249
2,244,219	6/1941	Sampson .	
2,384,437	9/1945	Boynton .	

2,771,803	11/1956	Staples et al. .	
2,815,053	12/1957	Walker .	
4,627,604	* 12/1986	Choi	269/249
5,586,378	* 12/1996	Smith	29/257
5,850,680	* 12/1998	Verrier et al.	269/249

* cited by examiner

Primary Examiner—Raphael Barkai

(74) *Attorney, Agent, or Firm*—Pearson & Pearson, LLP

(57) **CLAIM**

The ornamental design for the clamp, as shown and described.

DESCRIPTION

FIG. 1 is a front perspective view of the improved clamp showing my new design;
 FIG. 2 is a front elevational view of the improved clamp thereof;
 FIG. 3 is a rear elevational view of the improved clamp thereof;
 FIG. 4 is a top plan view of the improved clamp;
 FIG. 5 is a bottom plan view of the improved clamp;
 FIG. 6 is a right side elevational view of the improved clamp thereof;
 FIG. 7 is a left side elevational view of the improved clamp thereof; and,
 FIG. 8 is a partial view of the improved clamp from the top.

1 Claim, 6 Drawing Sheets

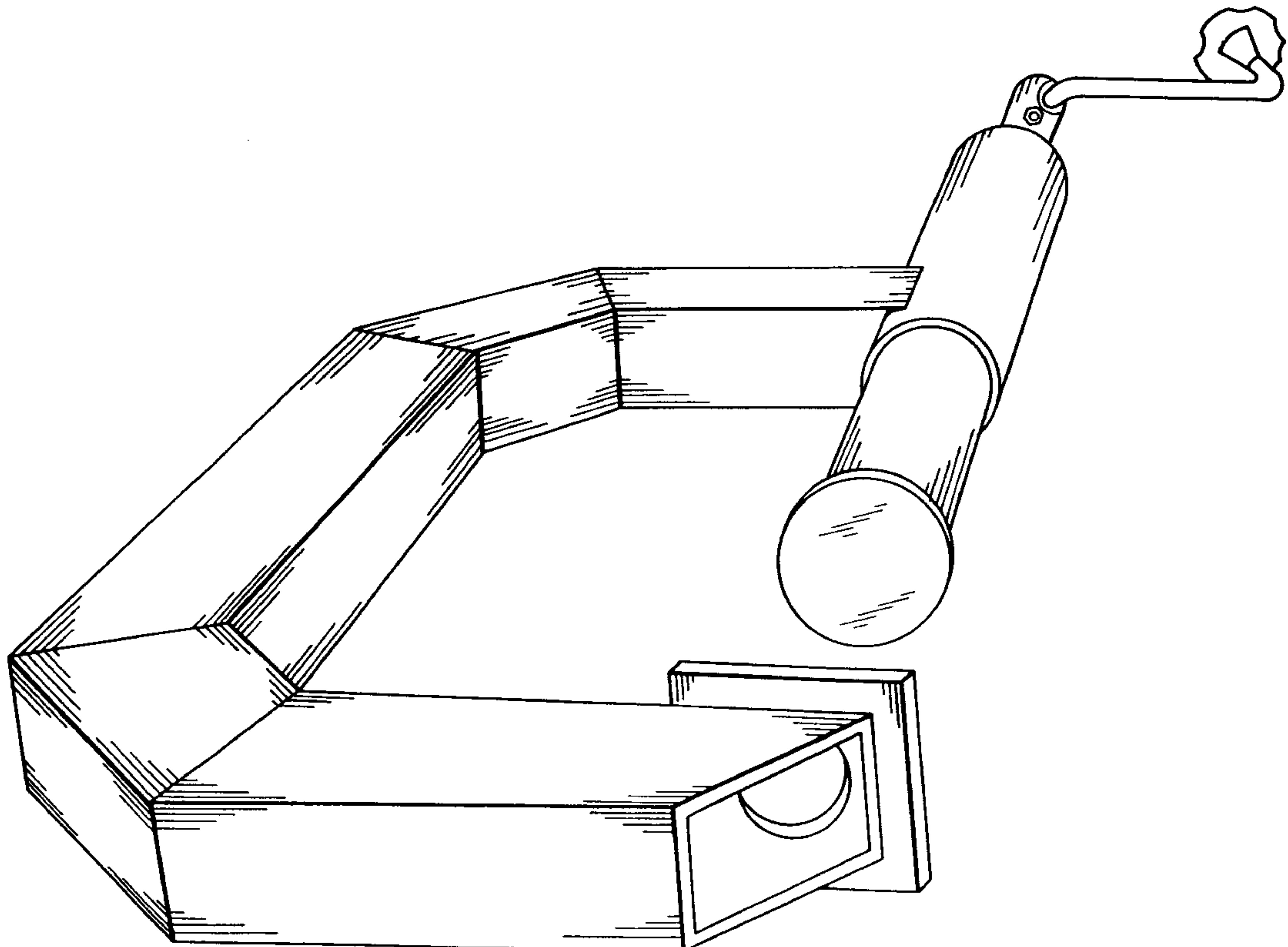

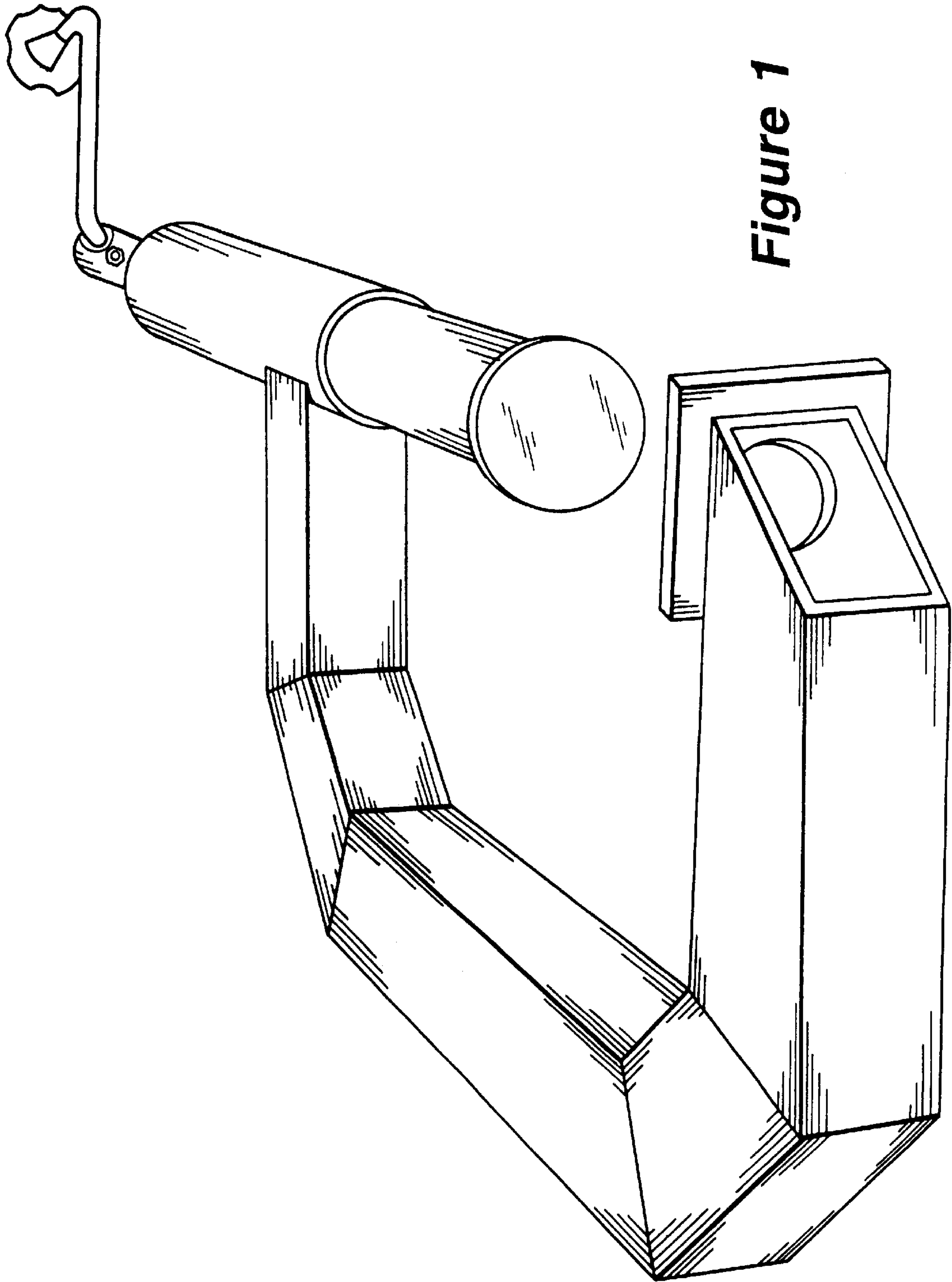
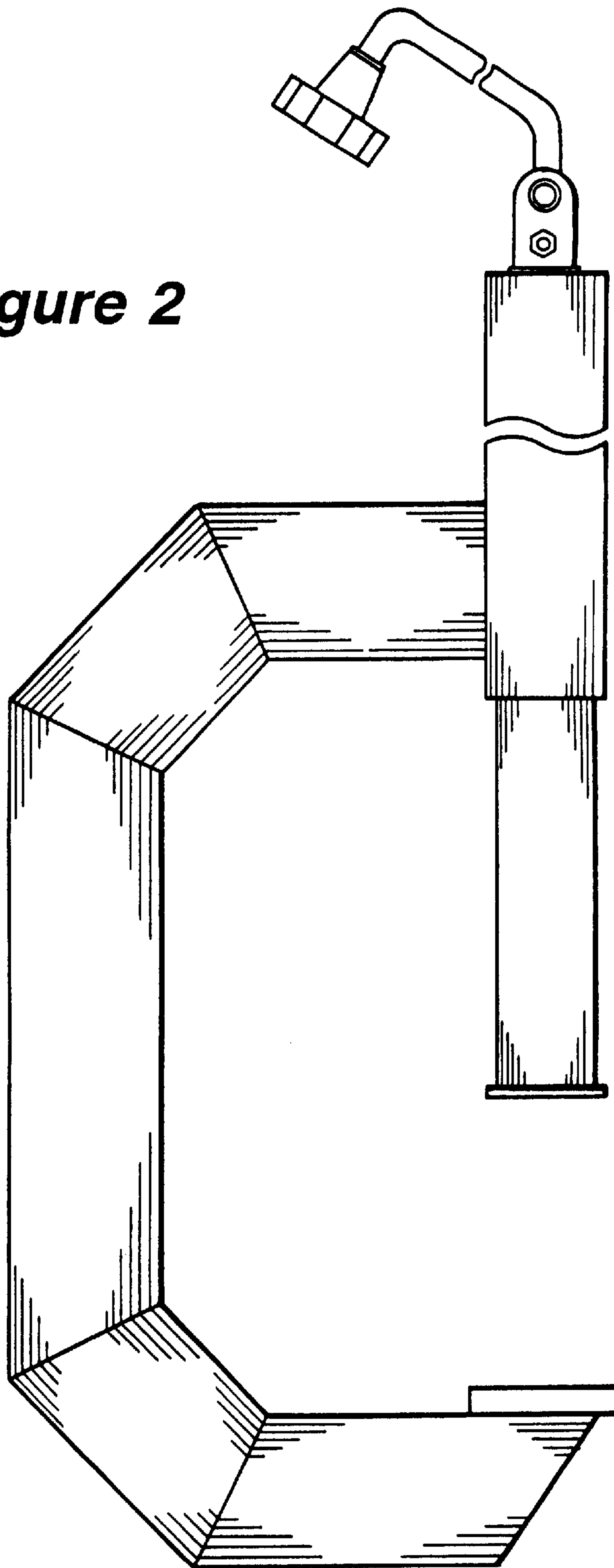

Figure 1

Figure 2



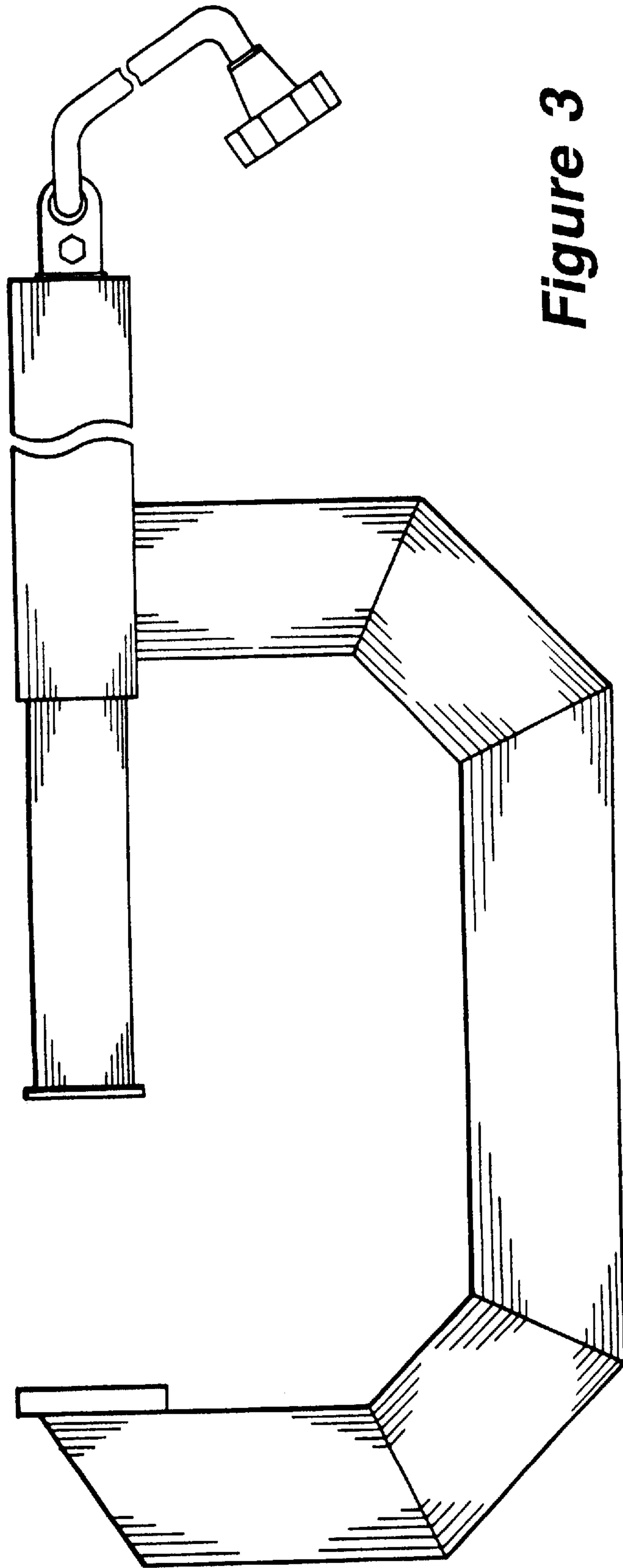

Figure 3

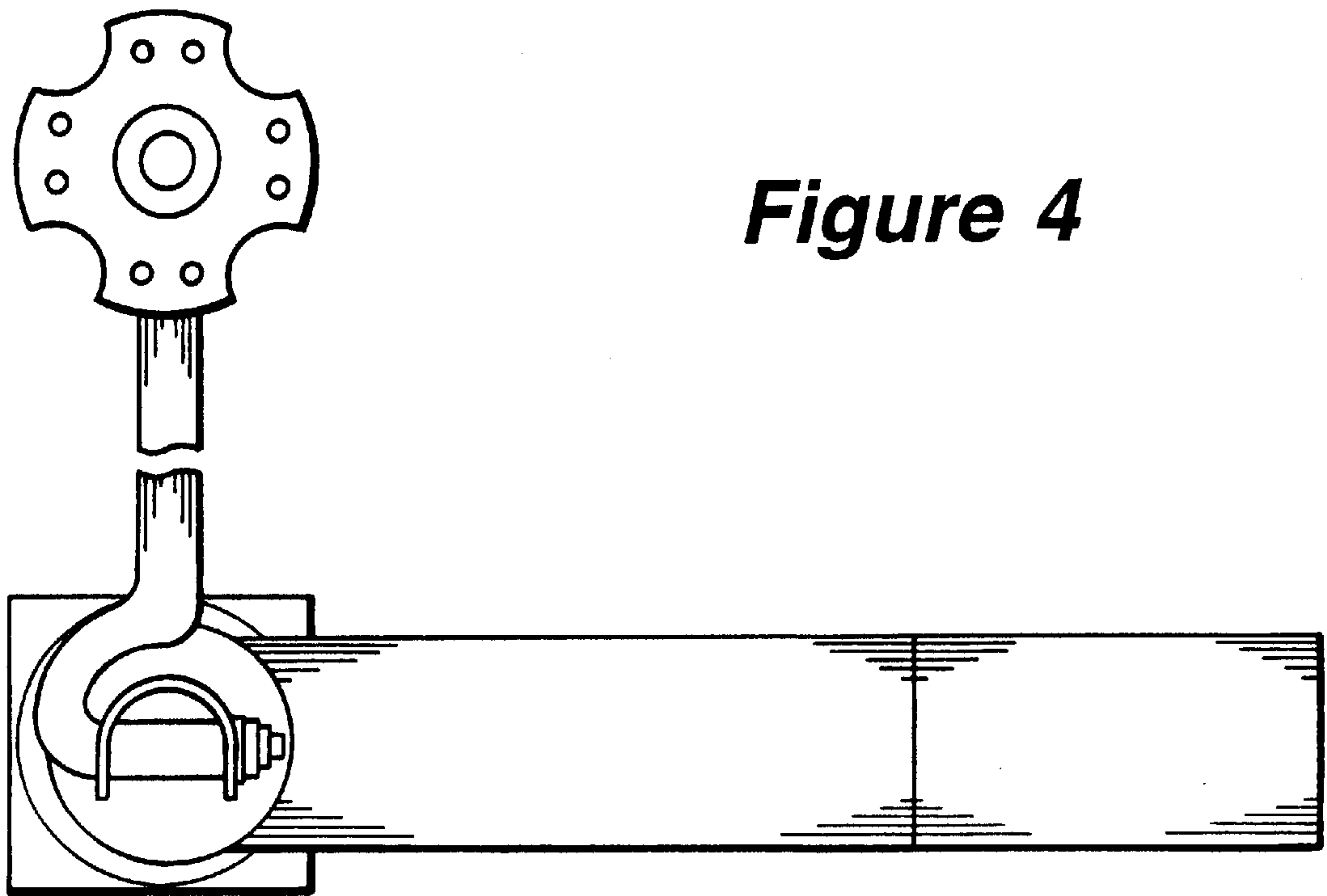

Figure 4

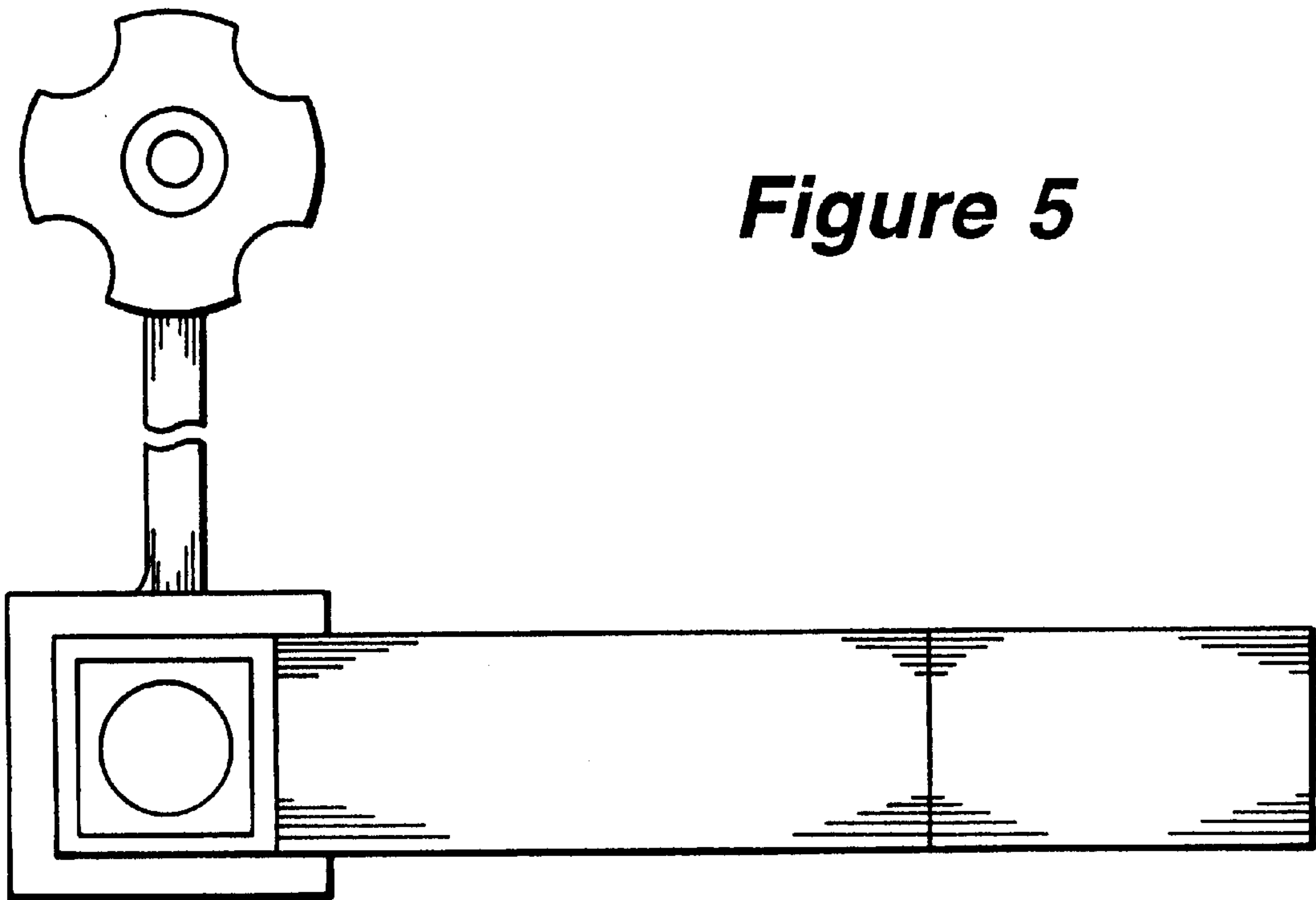

Figure 5

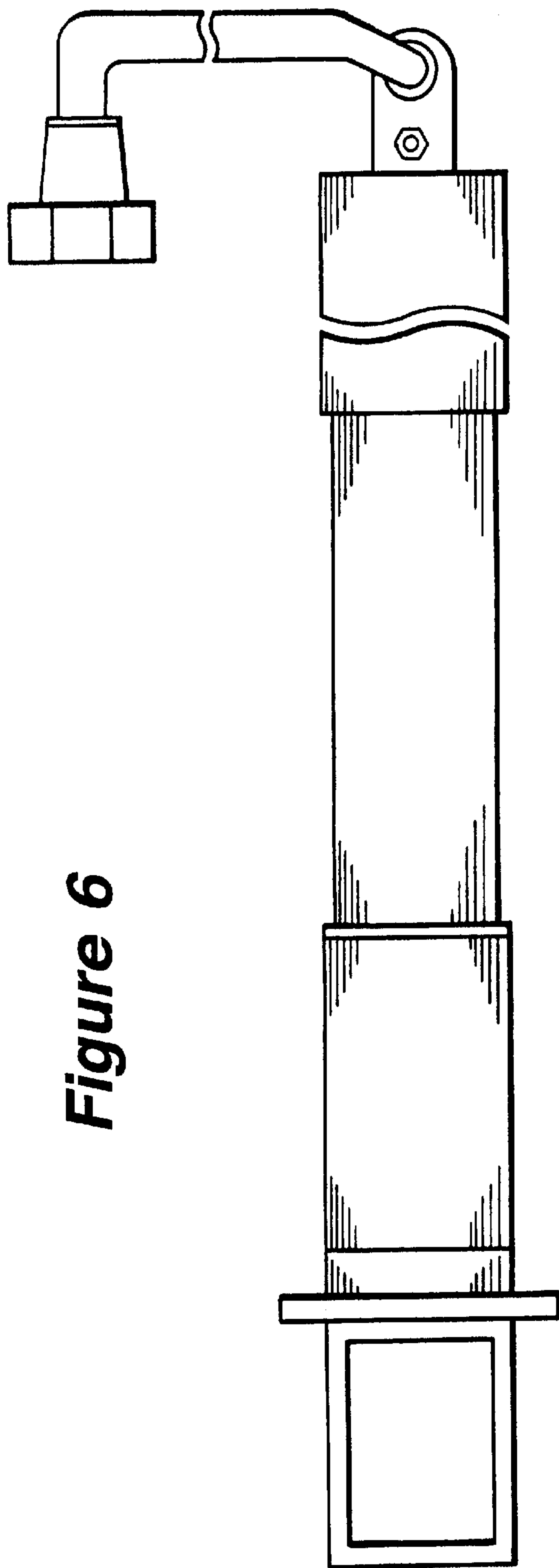

Figure 6

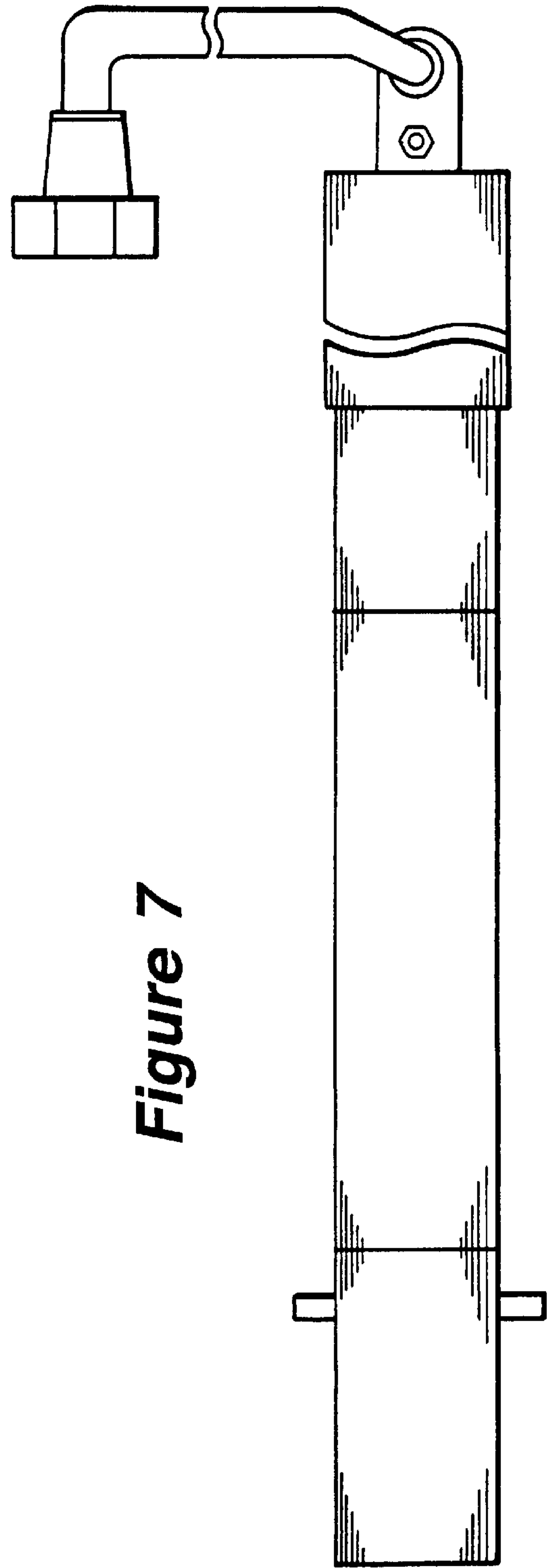

Figure 7

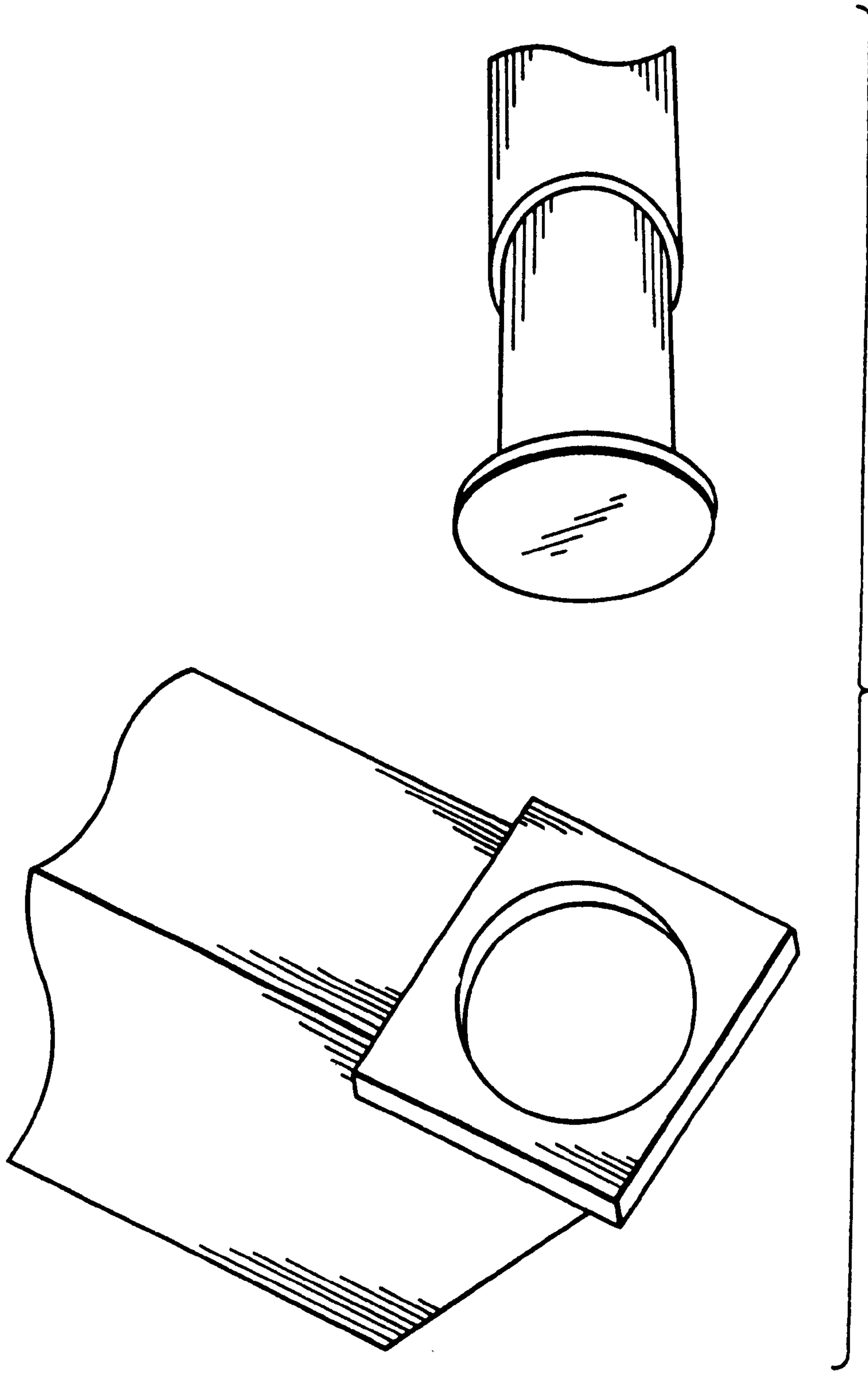

Figure 8