



US00D450948B1

(12) **United States Design Patent**  
**Stafford et al.**

(10) **Patent No.:** **US D450,948 S**

(45) **Date of Patent:** **\*\* Nov. 27, 2001**

(54) **MERCHANDISING FIXTURE**

(75) Inventors: **William Y. Stafford**, Minnetrista; **Judy Bell**, Minneapolis; **Michael Whittier**, Minneapolis; **Jeremy A. Clark**, Minneapolis, all of MN (US)

(73) Assignee: **Target Brands, Inc.**, Minneapolis, MN (US)

(\*\*) Term: **14 Years**

(21) Appl. No.: **29/138,749**

(22) Filed: **Mar. 19, 2001**

(51) **LOC (7) Cl.** ..... **06-04**

(52) **U.S. Cl.** ..... **D6/411**

(58) **Field of Search** ..... D6/343, 397, 409-415, D6/458, 462-468, 477, 479, 475, 455, 456, 546, 548; 108/50.11, 59, 91, 92, 93; 211/13.1, 37, 38, 85.3, 85.4, 30, 34, 42, 49.1, 90.03, 106, 119, 134, 186-189, 181.1, 200, 204-208; 248/441.1, 465.1, 175, 451, 124.1, 448

(56) **References Cited**

**U.S. PATENT DOCUMENTS**

- D. 211,838 7/1968 Gelles .
- D. 263,358 3/1982 Winter et al. .
- D. 277,626 2/1985 Evans .
- D. 290,791 7/1987 Kester .
- D. 291,036 7/1987 Scarpa et al. .
- D. 300,289 3/1989 Walter .
- D. 301,413 6/1989 Rosen .
- D. 314,090 1/1991 Stephens et al. .
- D. 314,286 2/1991 Glassenberg .
- D. 318,194 7/1991 Terrell et al. .
- D. 319,934 9/1991 Terrell et al. .
- D. 321,997 12/1991 Inman .
- D. 322,188 12/1991 Leis et al. .
- D. 326,965 6/1992 Allen .
- D. 327,788 7/1992 Allen .
- D. 328,825 8/1992 Allen .
- D. 328,830 8/1992 Allen .
- D. 331,160 11/1992 Brunner .
- D. 331,331 12/1992 Brunner .

- D. 335,052 4/1993 Barbuto et al. .
- D. 335,592 5/1993 Barthelmess et al. .
- D. 394,360 5/1998 Geier et al. .
- D. 424,320 \* 5/2000 Klein et al. .... D6/411
- 2,896,789 \* 7/1959 Sans et al. .... 211/182 X
- 4,035,941 7/1977 Deffner .
- 4,186,666 2/1980 Honickman .
- 4,191,298 3/1980 Broudy .
- 4,324,076 4/1982 Honickman .
- 4,336,886 6/1982 Azoulay et al. .
- 4,508,231 4/1985 Honickman .
- 4,577,767 3/1986 Geschwender .
- 4,596,195 6/1986 Wenger .
- 4,655,354 4/1987 Cohen .
- 4,736,996 4/1988 Zeichner .
- 4,821,893 4/1989 Wyatt .
- 4,932,539 6/1990 Abinanti .
- 5,090,725 \* 2/1992 Feldner ..... 211/189
- 5,248,047 9/1993 Randhawa .
- 5,332,108 7/1994 Blass .
- 5,529,192 6/1996 Conen et al. .
- 5,542,758 8/1996 Brown .

\* cited by examiner

*Primary Examiner*—Cathron C. Brooks

(74) *Attorney, Agent, or Firm*—Faegre & Benson LLP

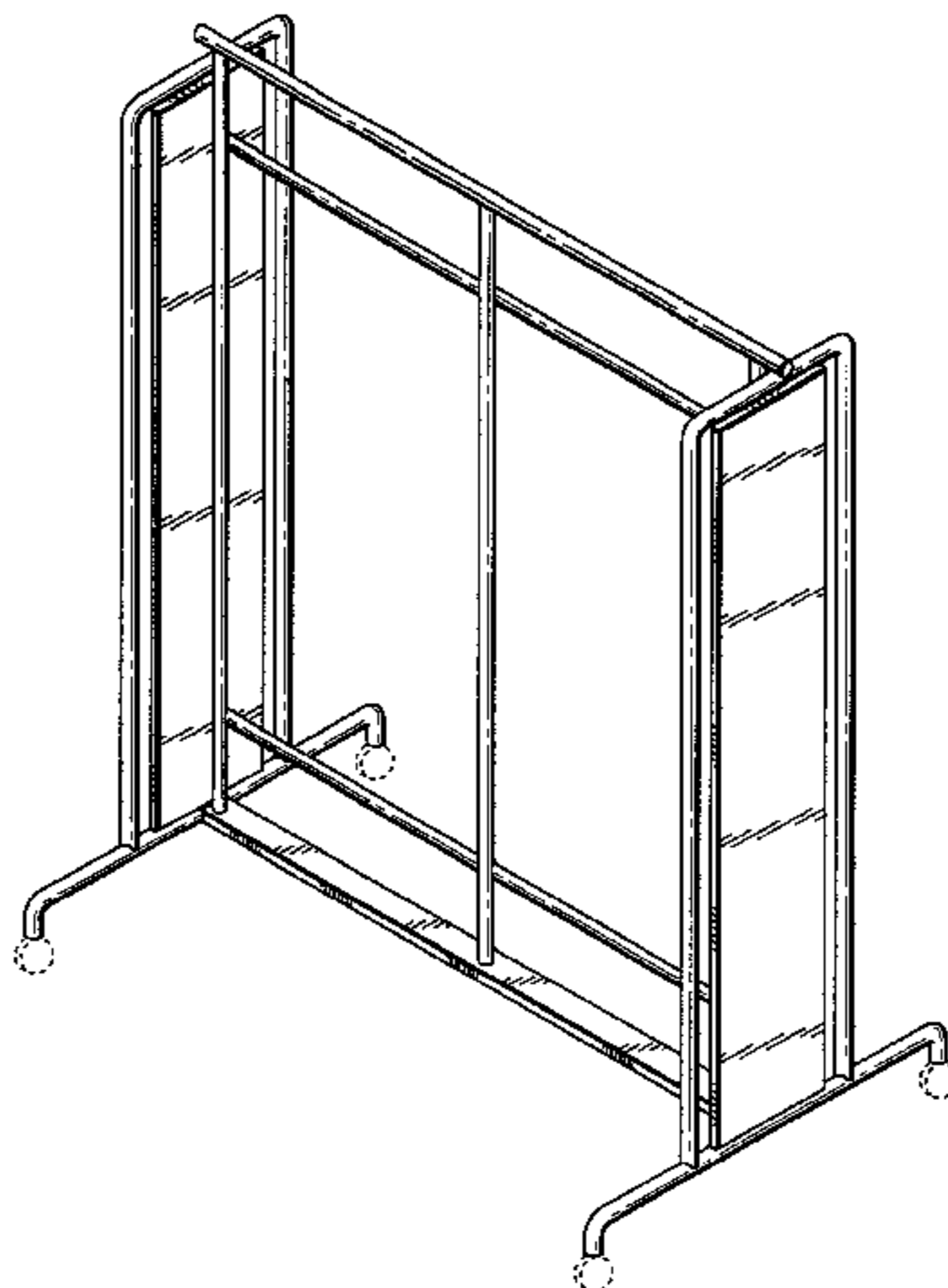
(57) **CLAIM**

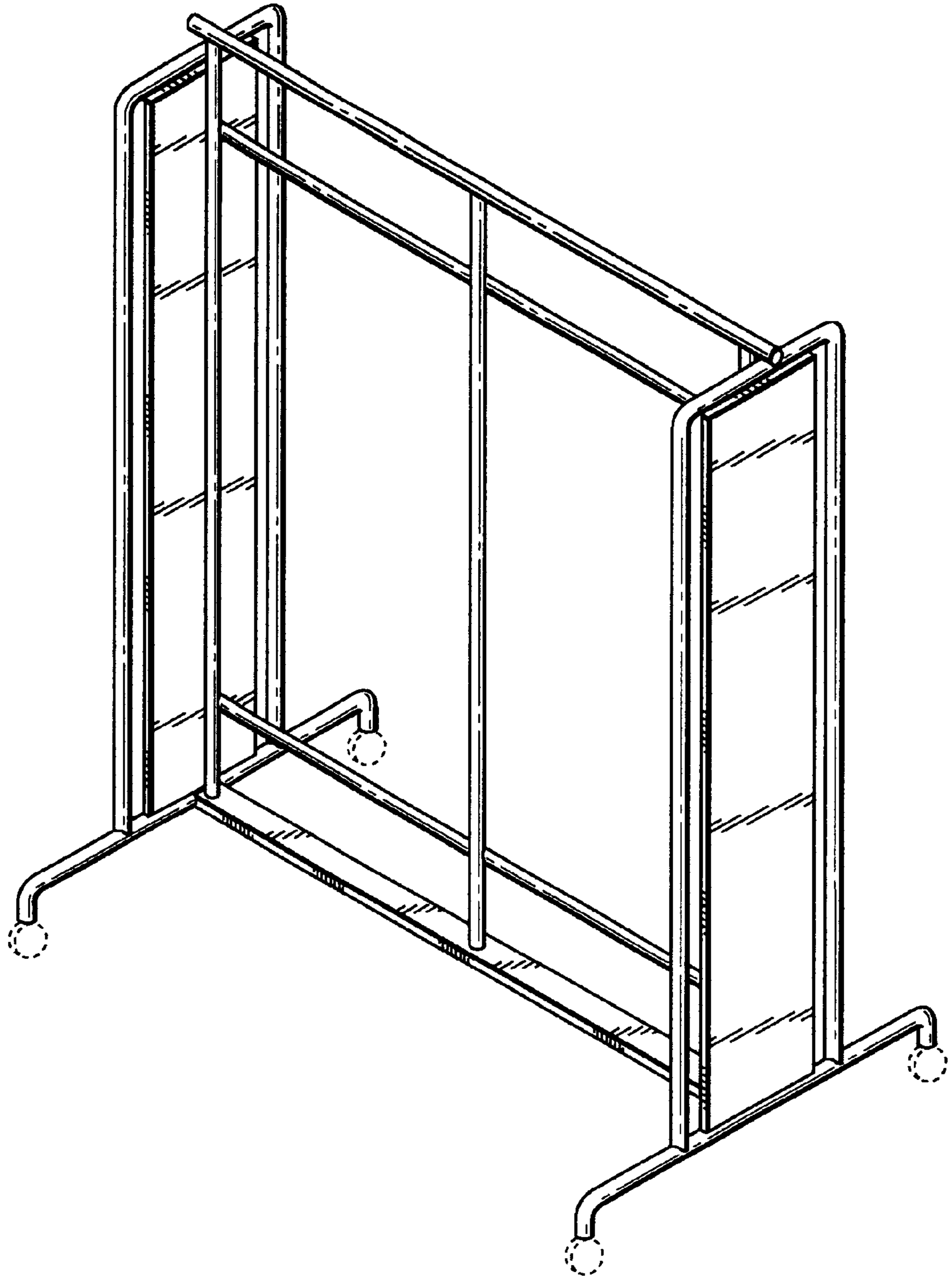
The ornamental design for a merchandising fixture, as shown and described.

**DESCRIPTION**

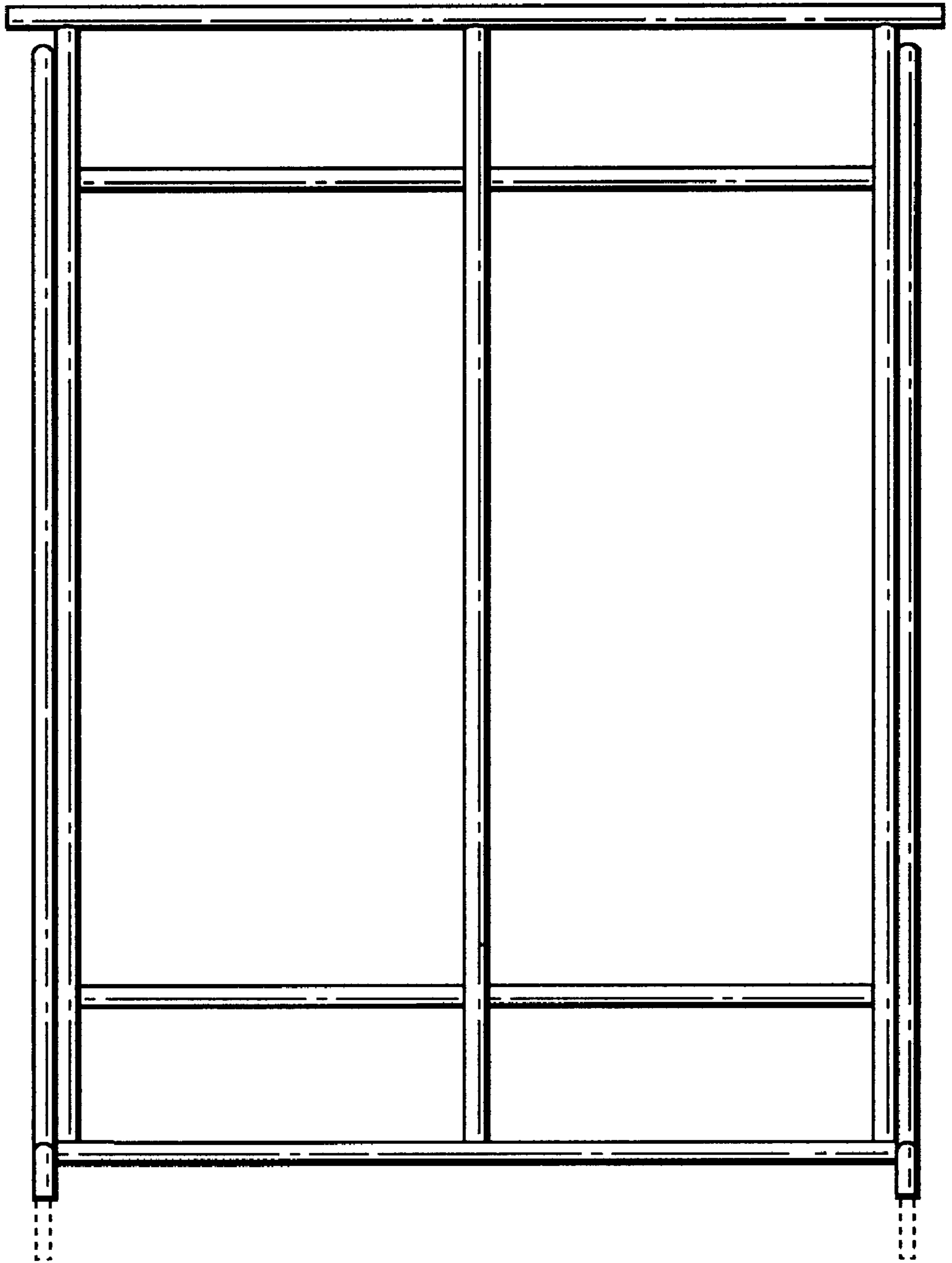
FIG. 1 is a view in perspective of a merchandising fixture. FIG. 2 is a front plan view of the merchandising fixture of FIG. 1. FIG. 3 is a rear plan view of the merchandising fixture of FIG. 1. FIG. 4 is a top view of the merchandising fixture of FIG. 1. FIG. 5 is a bottom view of the merchandising fixture of FIG. 1; and, FIG. 6 is a side view of the merchandising fixture of FIG. 1. The broken lines shown are for illustrative purposes only and form no part of the claimed design.

**1 Claim, 5 Drawing Sheets**

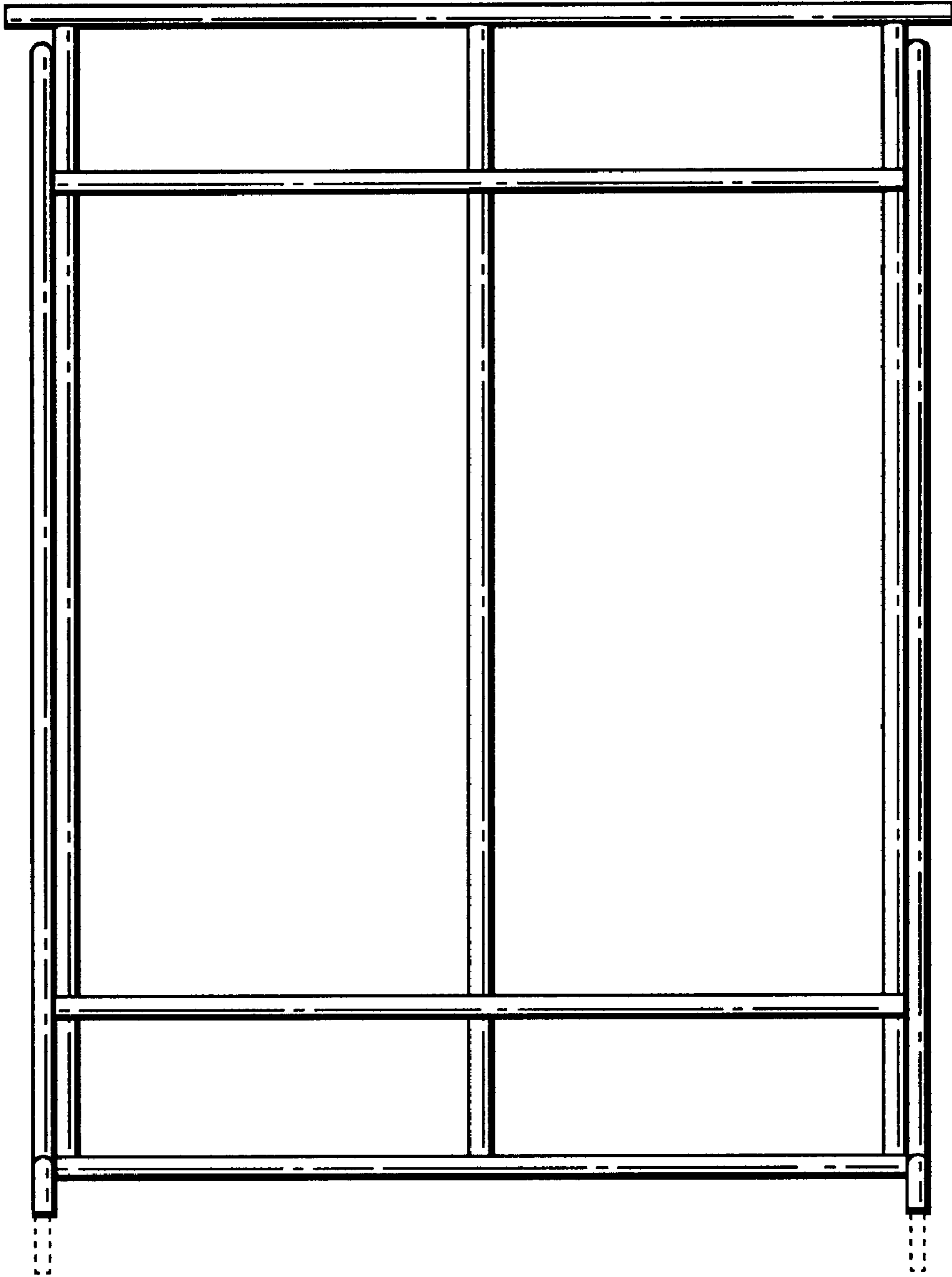




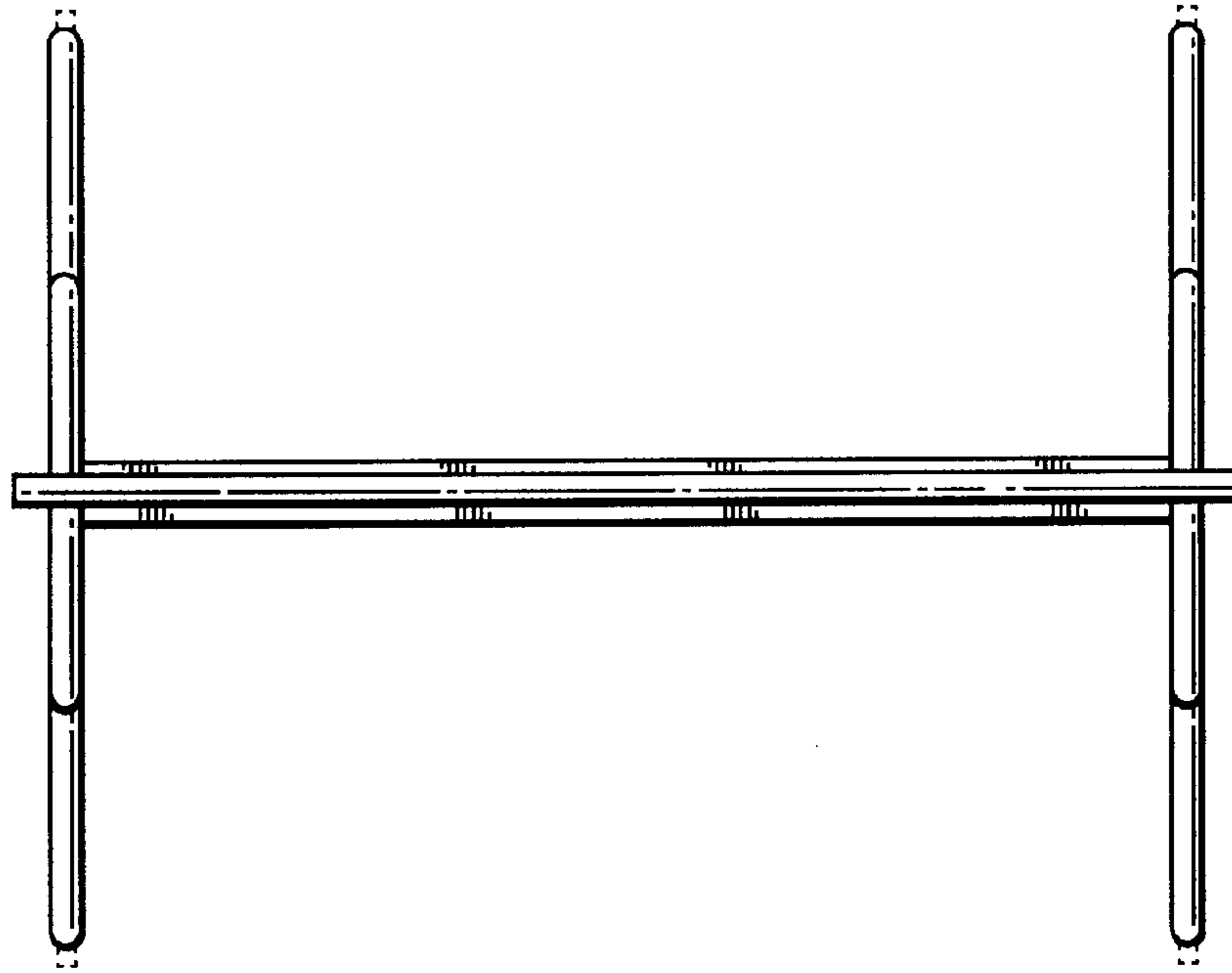
**Fig. 1**



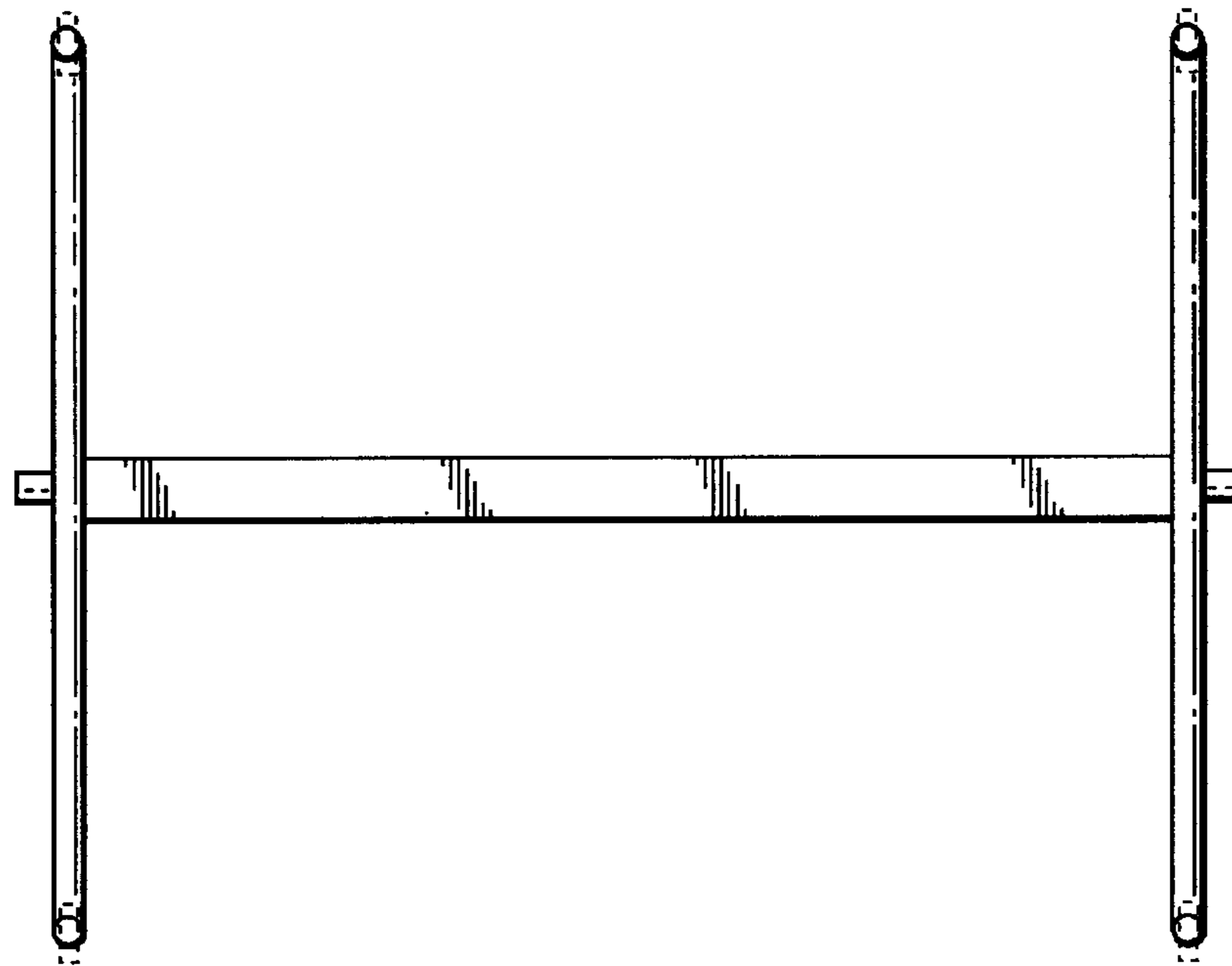
**Fig. 2**



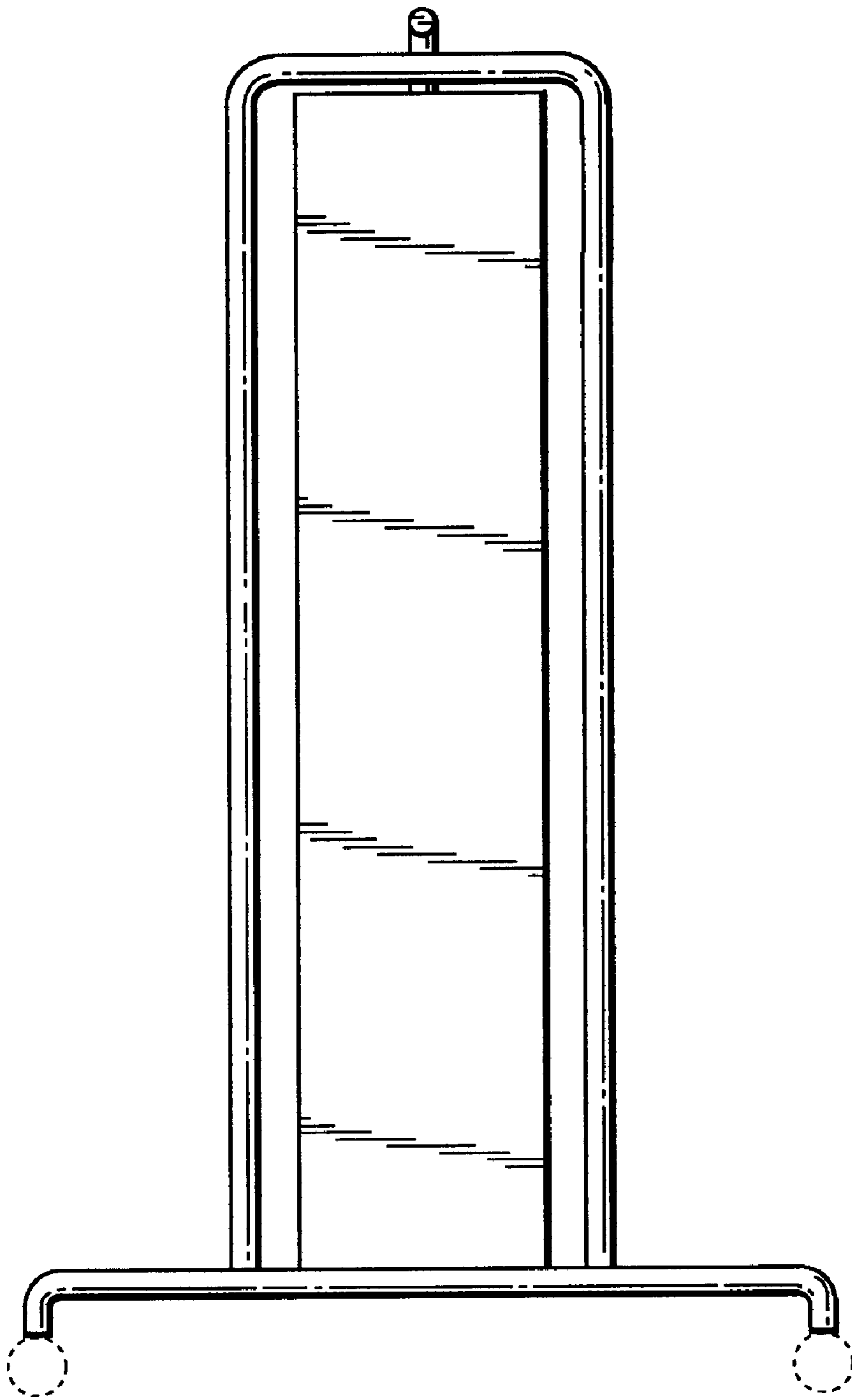
**Fig. 3**



**Fig. 4**



**Fig. 5**



**Fig. 6**