



US00D450819B1

(12) **United States Design Patent**  
**Breshears et al.**

(10) **Patent No.:** **US D450,819 S**

(45) **Date of Patent:** **\*\* Nov. 20, 2001**

(54) **HEATER**

(75) Inventors: **John C. Breshears**, LaCrosse; **Larry R. Romeiser**, Bison, both of KS (US)

(73) Assignee: **Flame Engineering, Inc.**, LaCrosse, KS (US)

(\*\*) Term: **14 Years**

(21) Appl. No.: **29/137,665**

(22) Filed: **Feb. 26, 2001**

(51) **LOC (7) Cl.** ..... **23-03**

(52) **U.S. Cl.** ..... **D23/342**

(58) **Field of Search** ..... D23/314, 324,  
D23/334, 317; 126/58, 64, 65, 85 R

(56) **References Cited**

**U.S. PATENT DOCUMENTS**

- D. 240,628 \* 7/1976 Kapustin .
- D. 270,087 \* 8/1983 Yarwood .
- D. 302,462 \* 7/1989 Pivonka .
- 1,454,556 \* 5/1923 Nietz .

- 1,458,668 \* 6/1923 Taylor .
- 3,623,458 \* 11/1971 Block .
- 4,350,139 \* 9/1982 Robichaud .
- 5,359,945 \* 11/1994 Buckner et al. .
- 5,553,604 \* 9/1996 Frei .

\* cited by examiner

*Primary Examiner*—B. J. Bullock

(74) *Attorney, Agent, or Firm*—Henderson & Sturm LLP

(57) **CLAIM**

The ornamental design for a heater, as shown and described.

**DESCRIPTION**

FIG. 1 is a perspective view of the heater showing our new design;

FIG. 2 is a front elevational view thereof;

FIG. 3 is a left-side elevational view thereof;

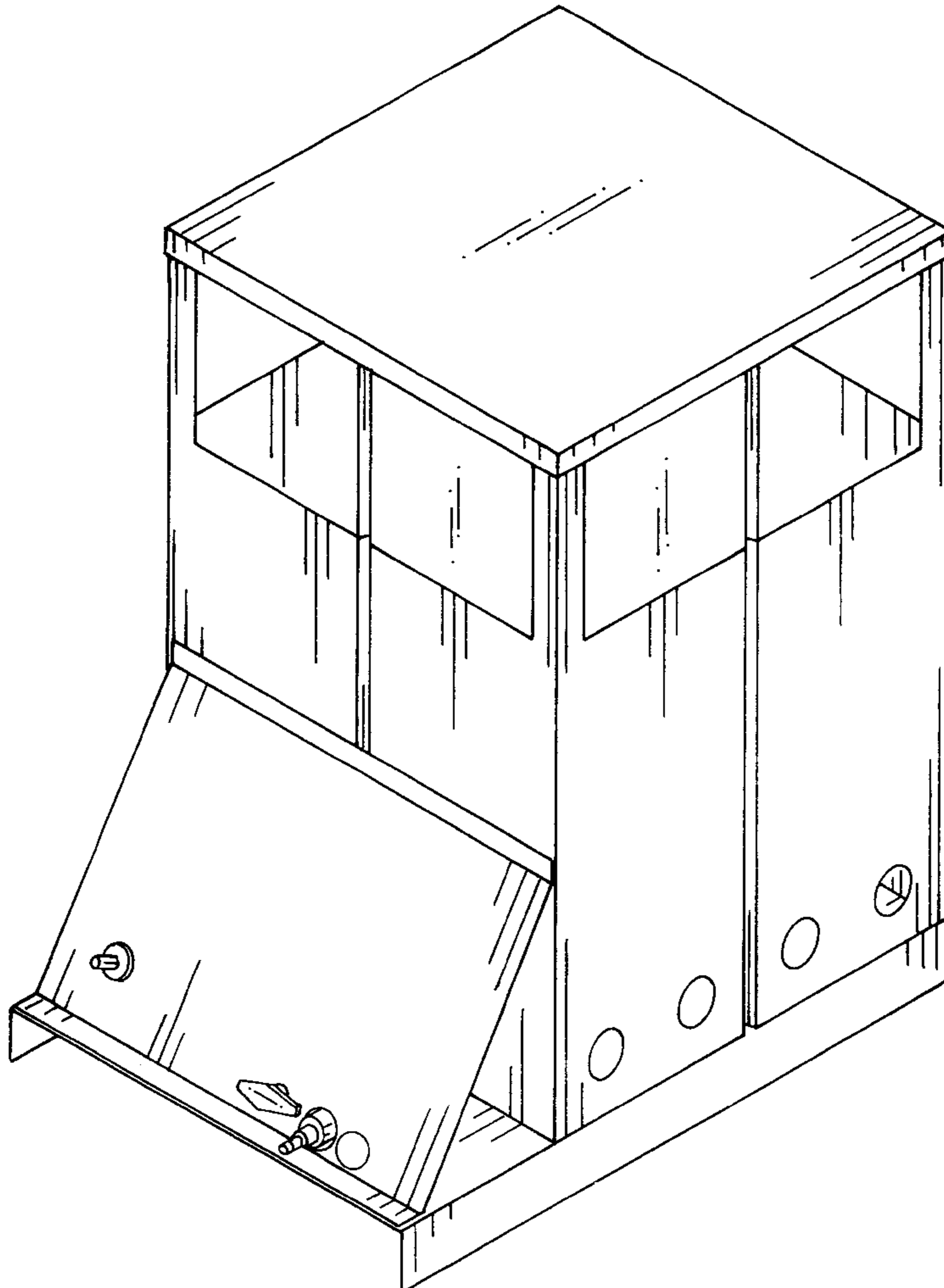
FIG. 4 is a right-side elevational view thereof;

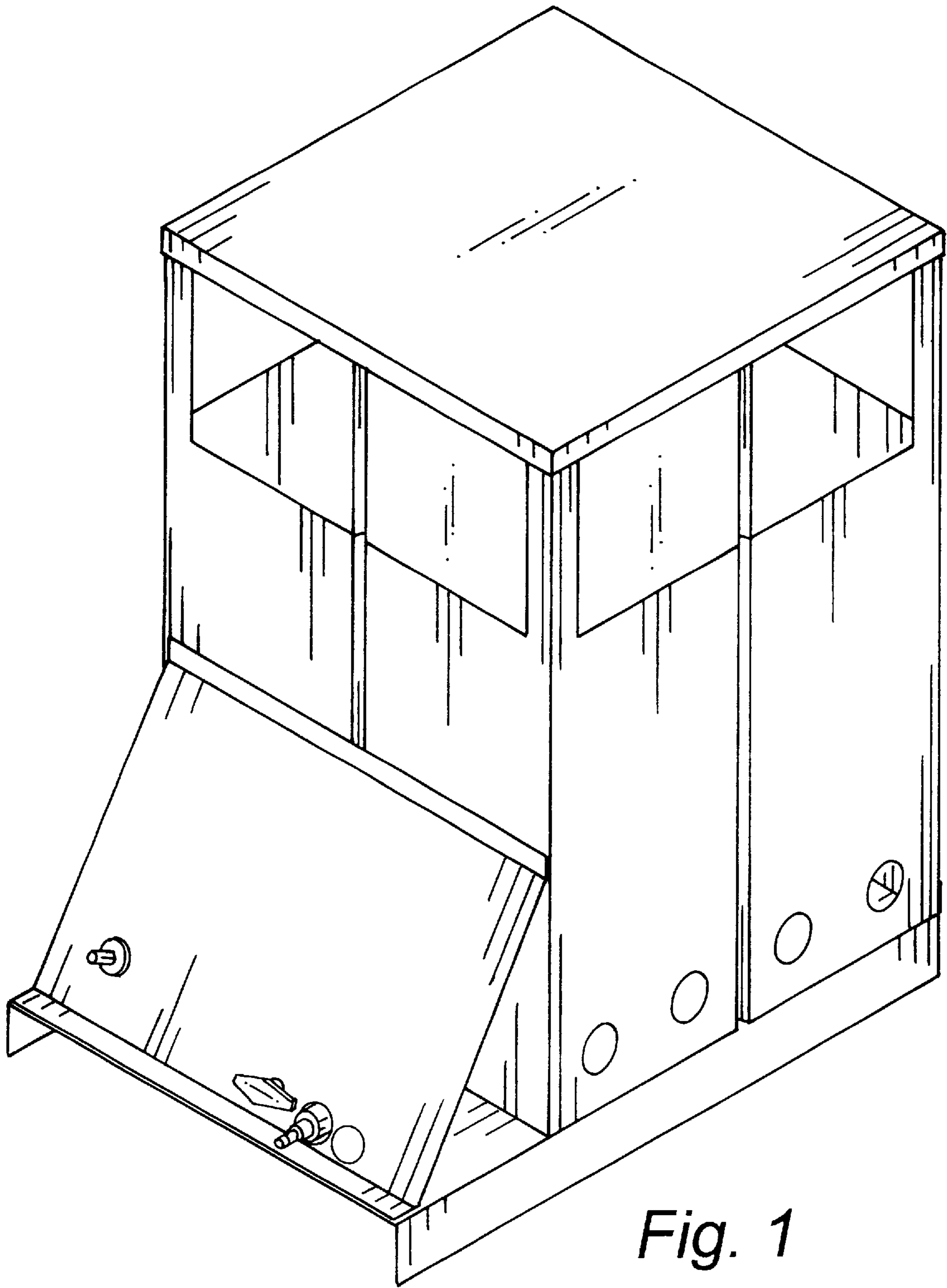
FIG. 5 is a rear elevational view thereof;

FIG. 6 is a top plan view thereof; and,

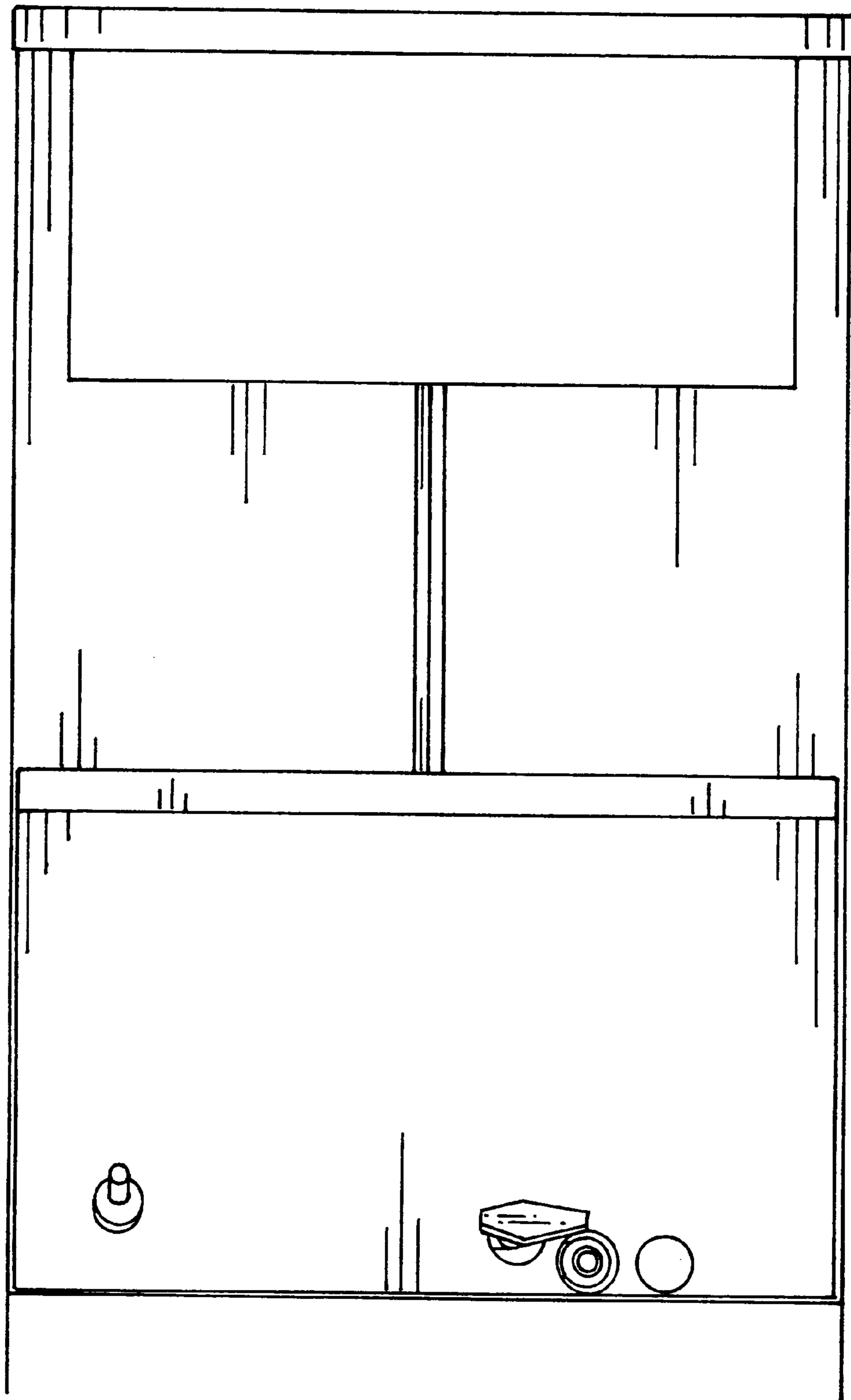
FIG. 7 is a bottom plan view thereof.

**1 Claim, 6 Drawing Sheets**

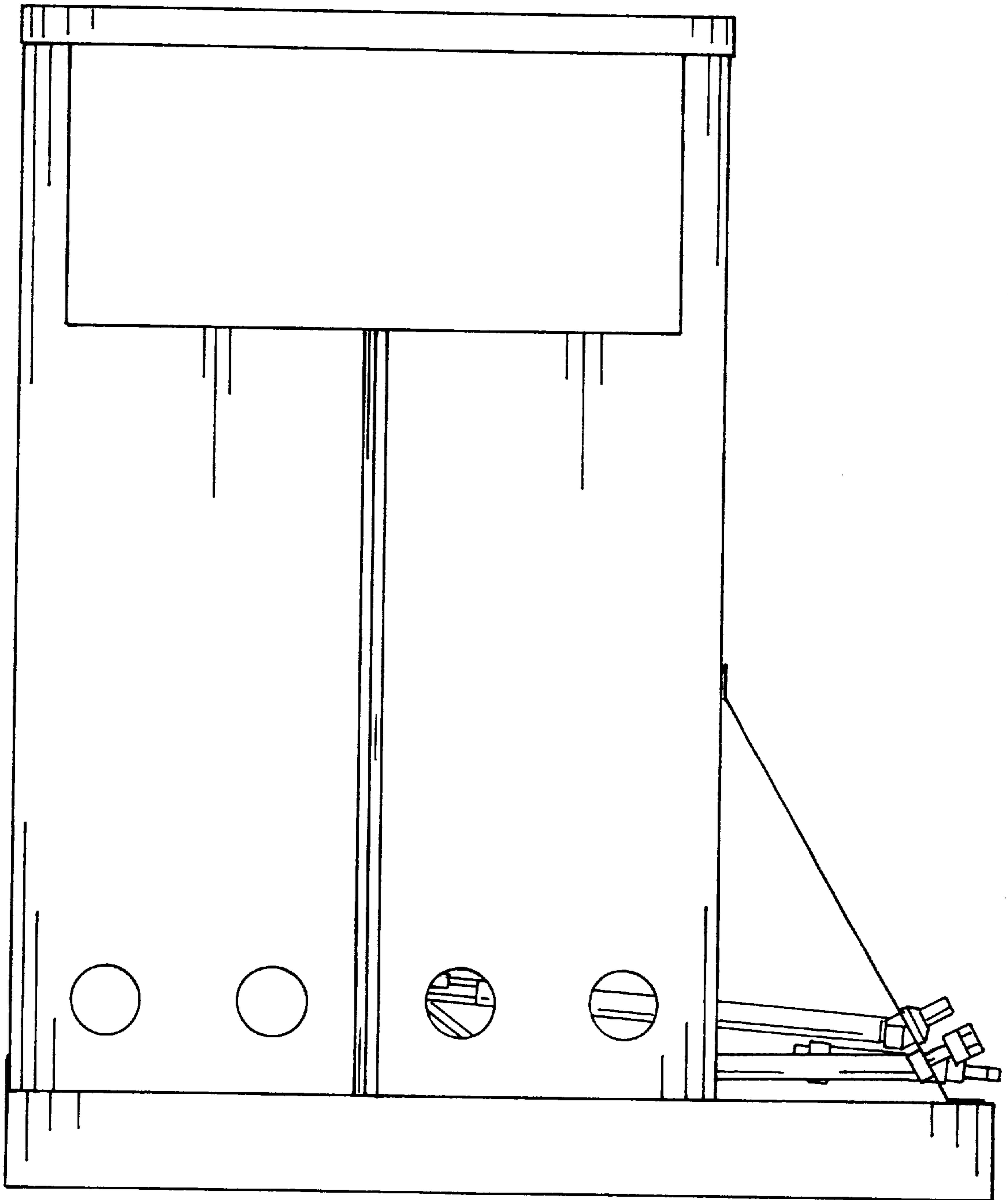




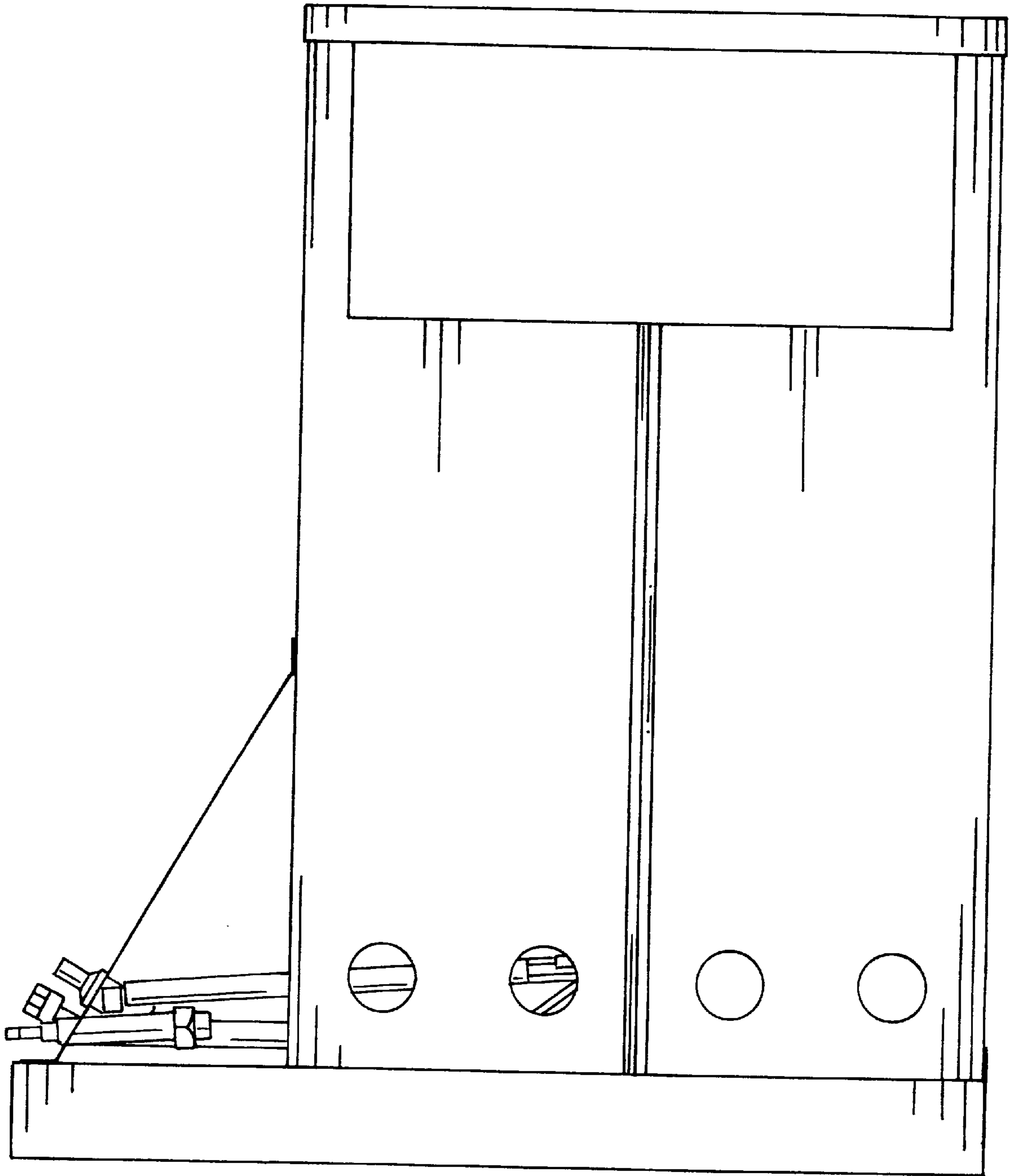
*Fig. 1*



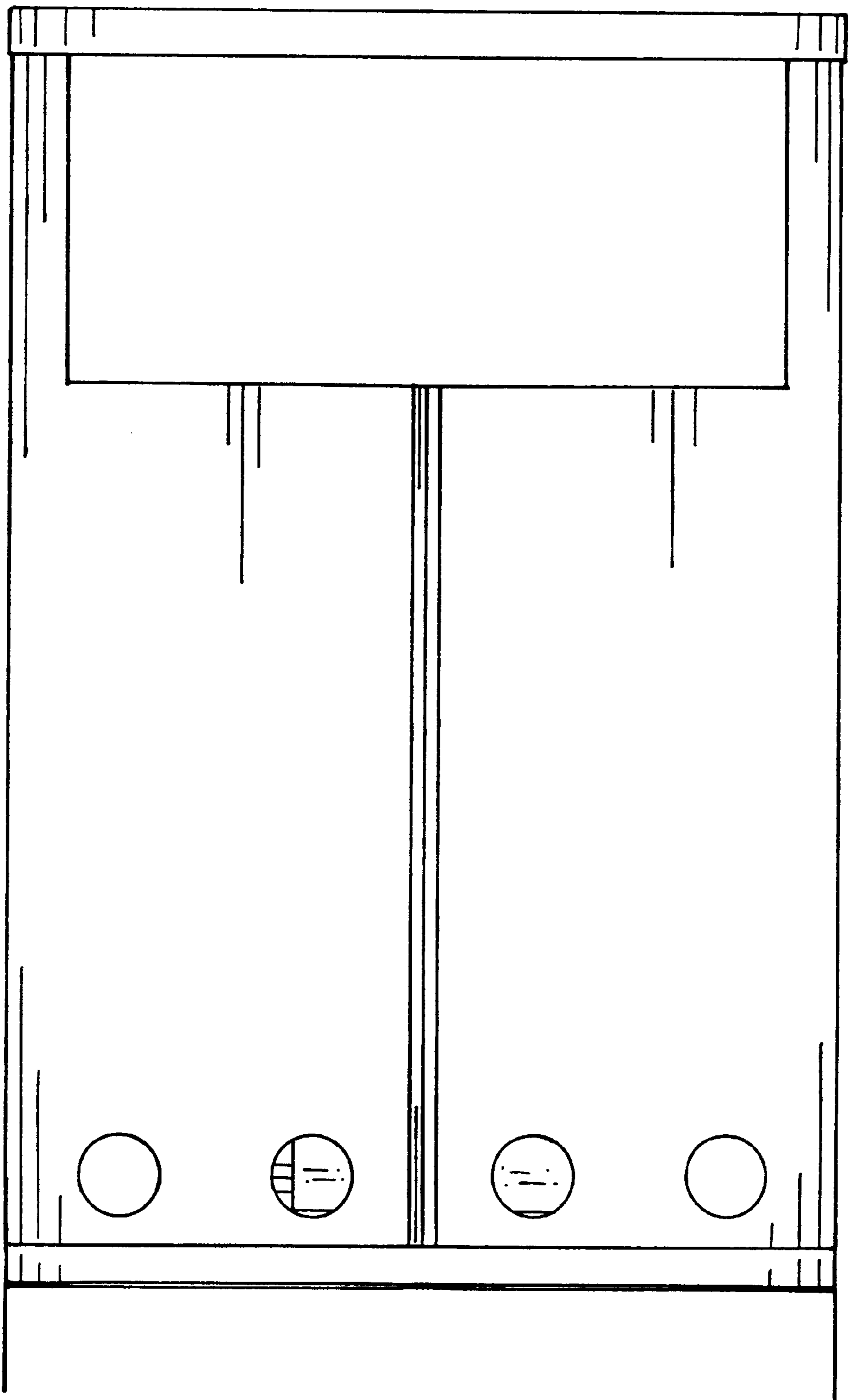
*Fig. 2*



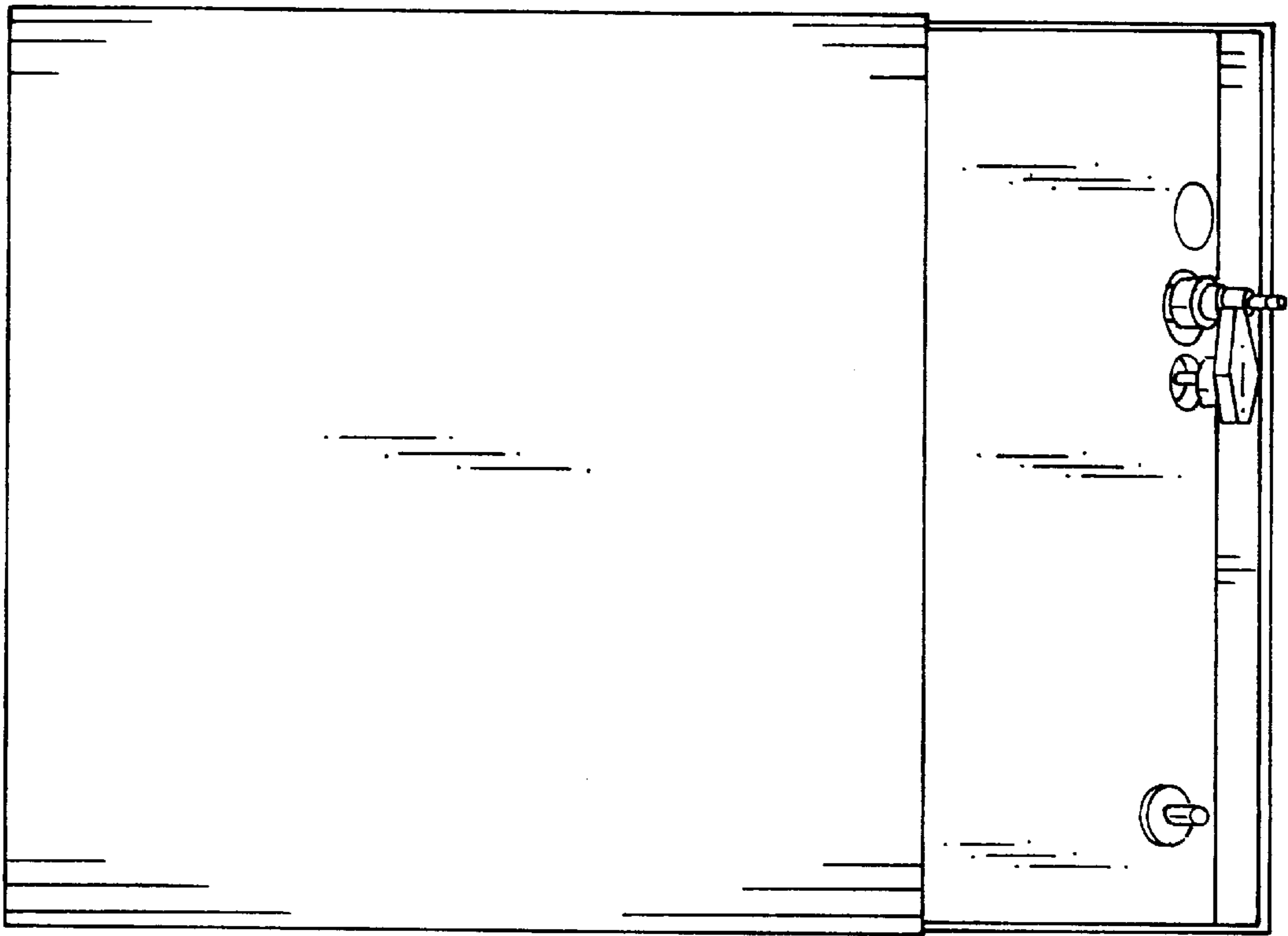
*Fig. 3*



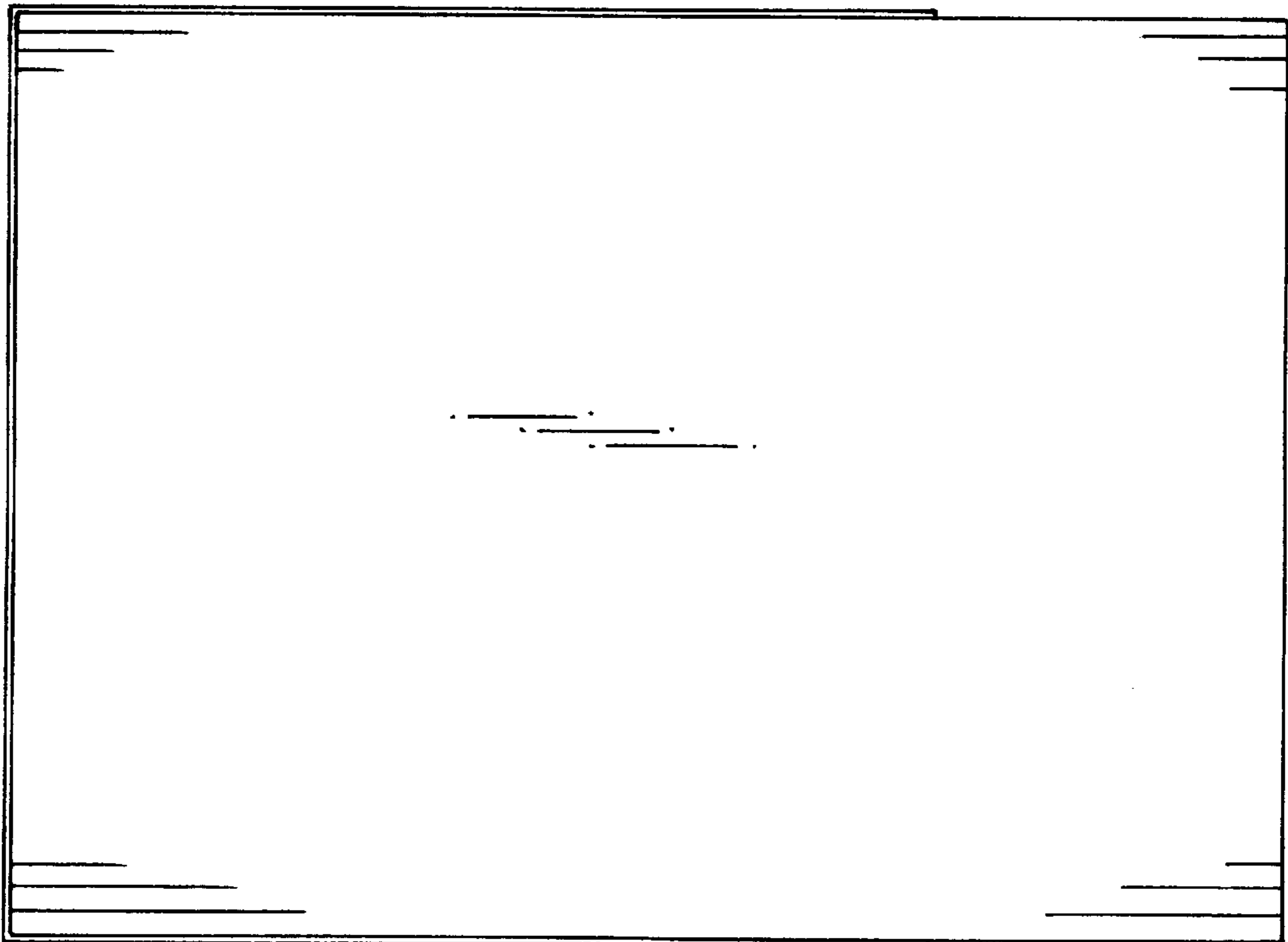
*Fig. 4*



*Fig. 5*



*Fig. 6*



*Fig. 7*