



US00D450561B1

(12) **United States Design Patent**  
**Moore et al.**

(10) **Patent No.:** **US D450,561 S**

(45) **Date of Patent:** **\*\* Nov. 20, 2001**

(54) **BRACKET ASSEMBLY FOR LOAD  
RESTRAINING VEHICULAR BARRIER  
DEVICE**

(75) Inventors: **Donal Moore**, Birmingham; **Brian  
Bateman**, Rochester Hills, both of MI  
(US)

(73) Assignee: **Polytech Netting, L.P.**, Troy, MI (US)

(\*\*) Term: **14 Years**

(21) Appl. No.: **29/126,791**

(22) Filed: **Jul. 24, 2000**

(51) **LOC (7) Cl.** ..... **08-08**

(52) **U.S. Cl.** ..... **D8/349; D8/383; D11/200**

(58) **Field of Search** ..... **D8/349, 383; D11/200,**  
**D11/218; 24/163 R, 68 R, 909, 585, 24,**  
**580; 410/96-97, 145, 106, 104, 148, 116,**  
**101, 100, 110, 146, 118, 137-138; 248/354.1,**  
**354.6, 499**

(56) **References Cited**

**U.S. PATENT DOCUMENTS**

D. 387,014	*	12/1997	Matoba	.....	D11/218
2,669,402		2/1954	Del Mar	.	
2,854,931		10/1958	Campbell	.	
2,997,331		8/1961	Kudner	.	
3,044,800		7/1962	Wicker	.	
3,049,373		8/1962	Biggers	.	
3,169,781		2/1965	Abruzzino	.	
3,190,686		6/1965	Smiler	.	
3,367,707		2/1968	Merriweather	.	
3,486,723		12/1969	Harrison	.	
3,534,998		10/1970	Johnson et al.	.	
3,695,698		10/1972	Trump	.	
4,173,369		11/1979	Roggin	.	
4,213,636		7/1980	King	.	
4,215,895		8/1980	Phillips	.	
4,368,902		1/1983	McDowell	.	
4,763,944		8/1988	Fry et al.	.	
4,846,610	*	7/1989	Schoenleben	.....	410/100

4,919,467		4/1990	Guimelli	.	
5,026,231		6/1991	Moore	.	
5,090,856		2/1992	Moore	.	
5,807,045	*	9/1998	Profit	.....	410/101
5,926,927	*	7/1999	Winkler	.....	24/68 R
5,967,720	*	10/1999	Profit	.....	410/101

**FOREIGN PATENT DOCUMENTS**

34-19758		11/1985	(DE)	.
3738931		6/1989	(DE)	.
2470033		11/1979	(FR)	.
2206548		1/1989	(GB)	.
61-193949		8/1986	(JP)	.

**OTHER PUBLICATIONS**

United Nations Agreement, Regulation No. 17, p. 11, Annex 7 and Annex 9.

\* cited by examiner

*Primary Examiner*—Pamela Burgess

(74) *Attorney, Agent, or Firm*—Young & Basile, P.C.

(57) **CLAIM**

The ornamental design for a bracket assembly for load restraining vehicular barrier device, as shown and described.

**DESCRIPTION**

FIG. 1 is a front perspective view of a bracket assembly for a load restraining vehicular barrier device showing my new design in a pre-assembled condition;

FIG. 2 is a rear perspective view thereof, of a bracket assembly for a load restraining vehicular barrier device;

FIG. 3 is a top plan view of FIG. 1, which is the mirror image of the bottom plan view;

FIG. 4 is a front elevational view of the bracket assembly for a load restraining vehicular barrier device in an assembled condition;

FIG. 5 is a rear elevational view thereof, of the bracket assembly for a load restraining vehicular barrier device;

FIG. 6 is a left end elevational view of FIG. 4; and,

FIG. 7 is a right end elevational view of FIG. 4.

**1 Claim, 2 Drawing Sheets**

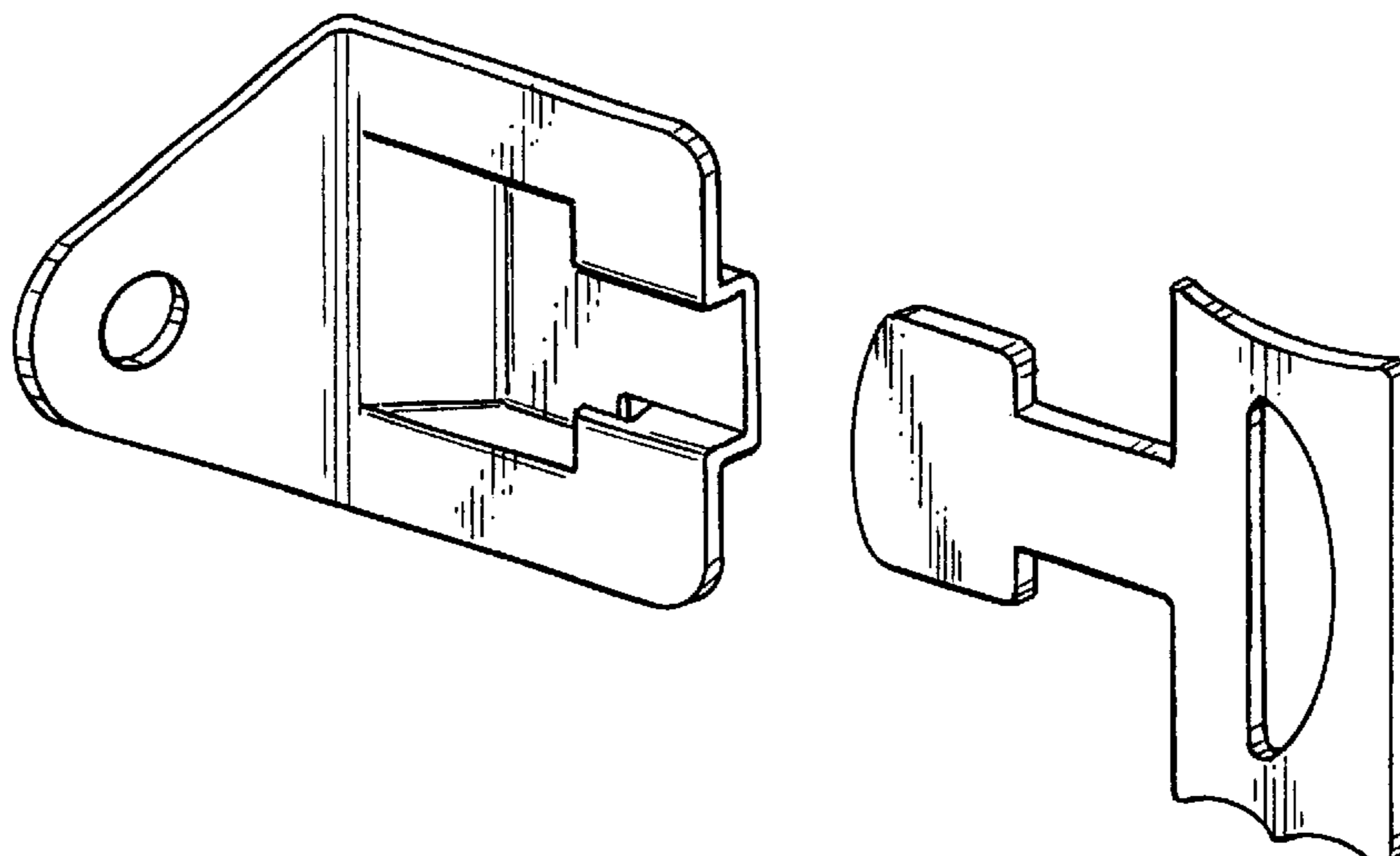

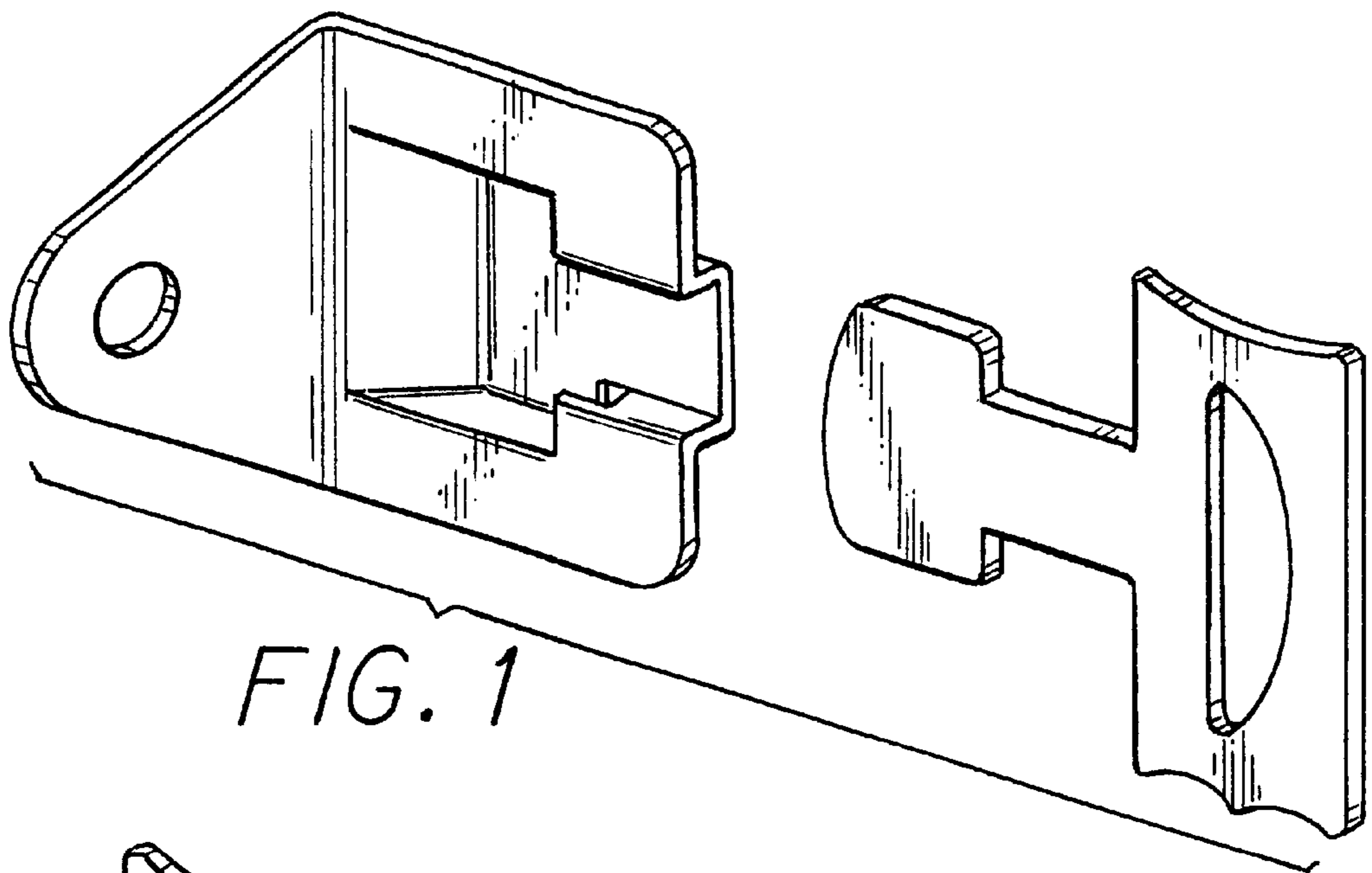

FIG. 1

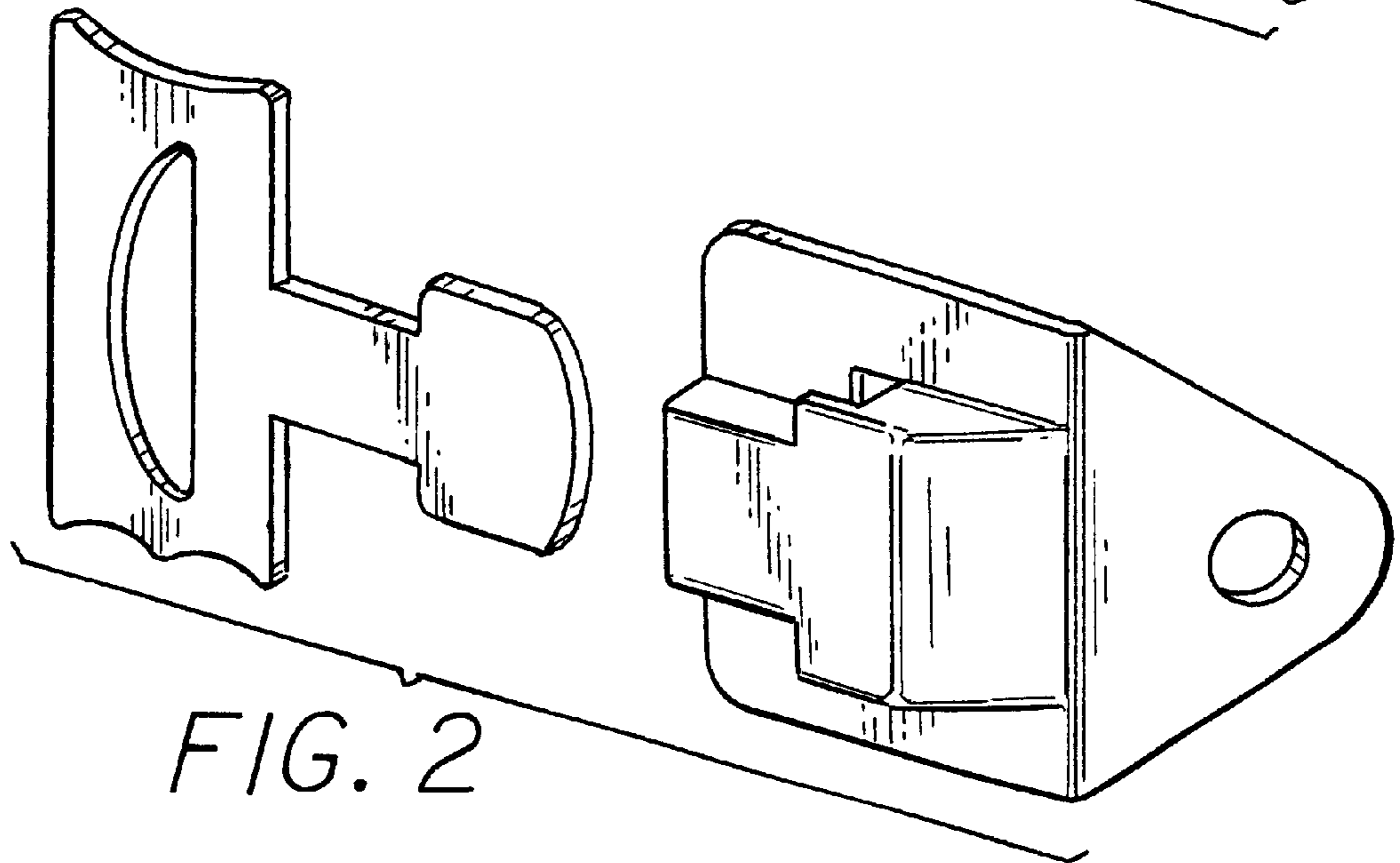

FIG. 2

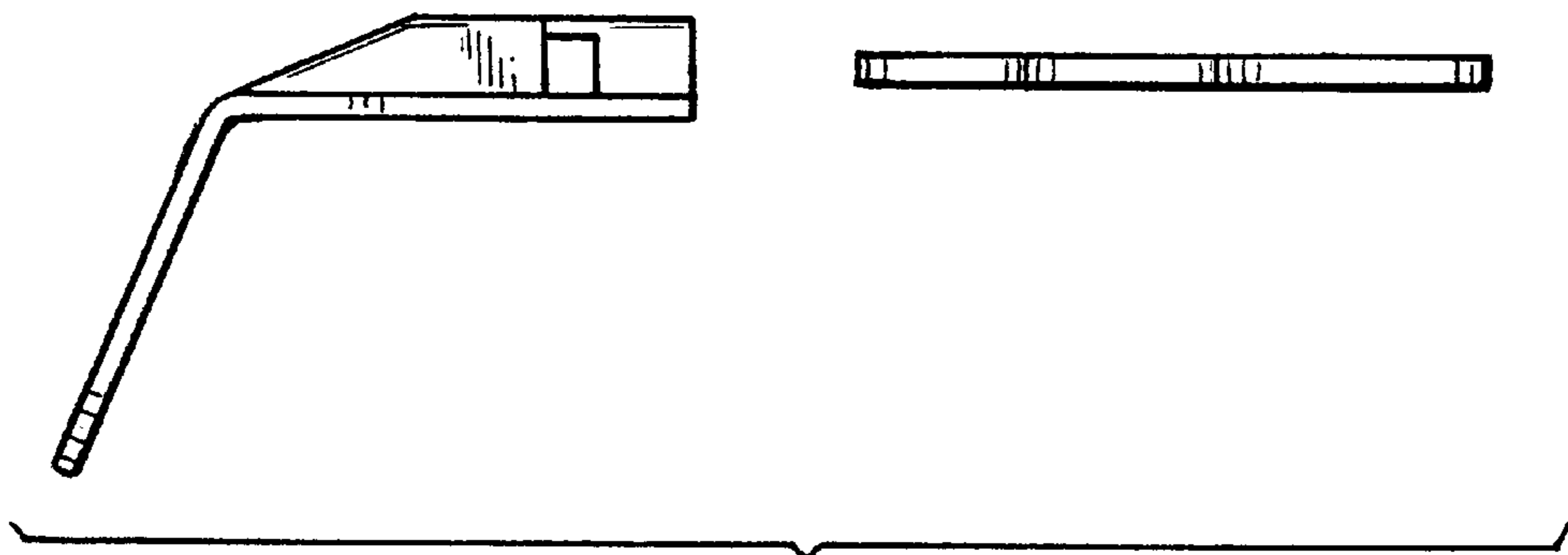

FIG. 3

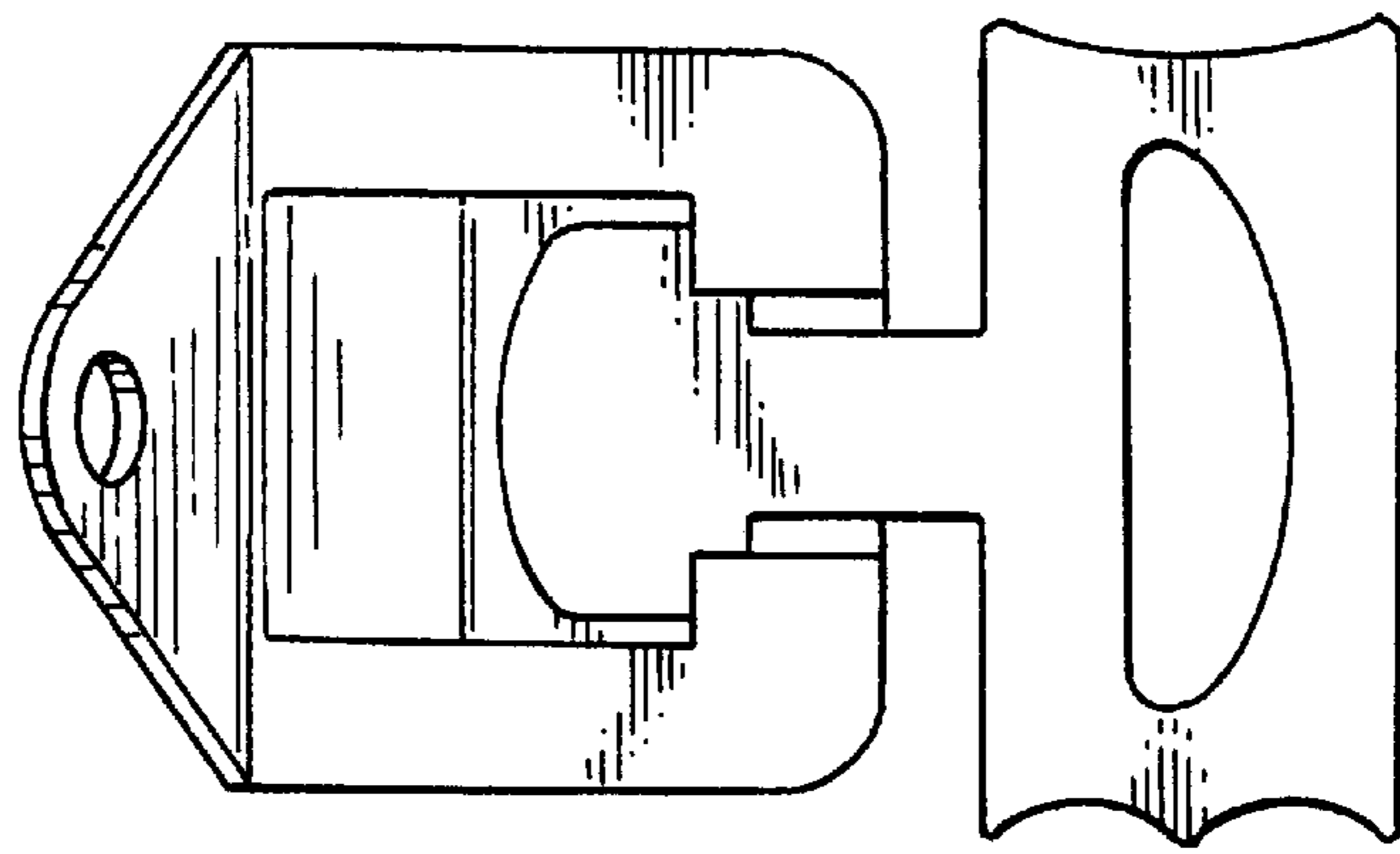

FIG. 4

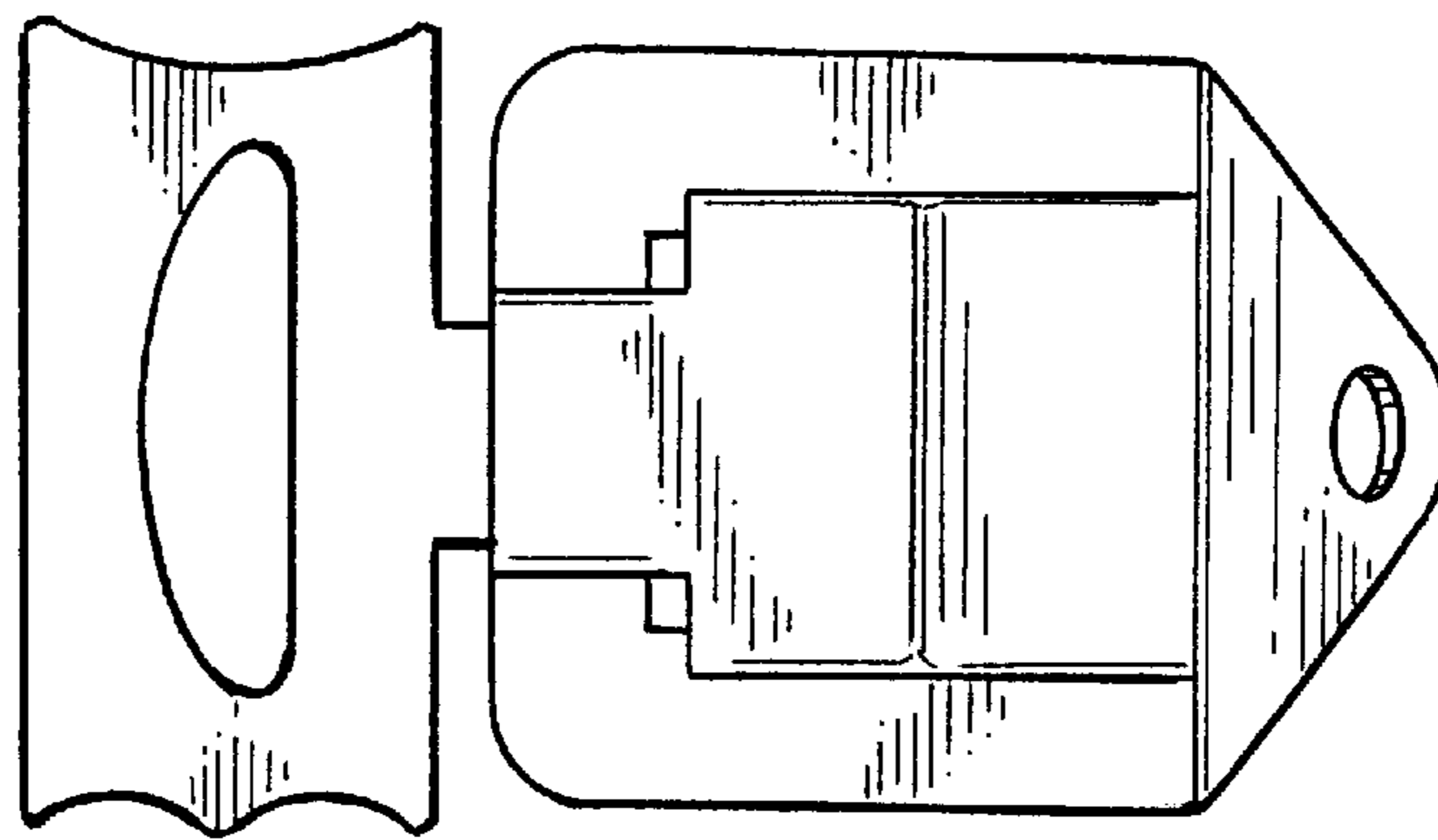

FIG. 5

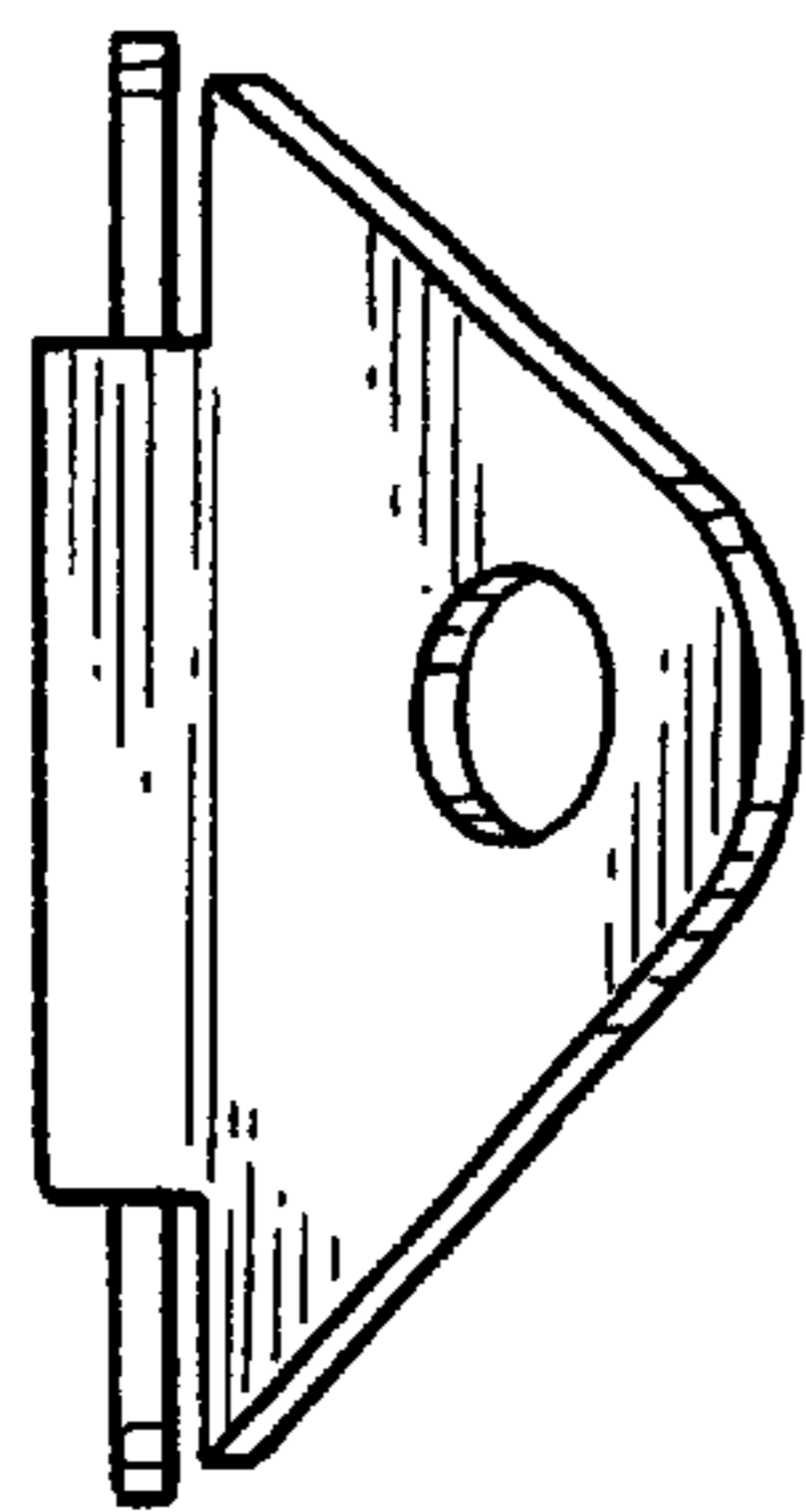

FIG 6

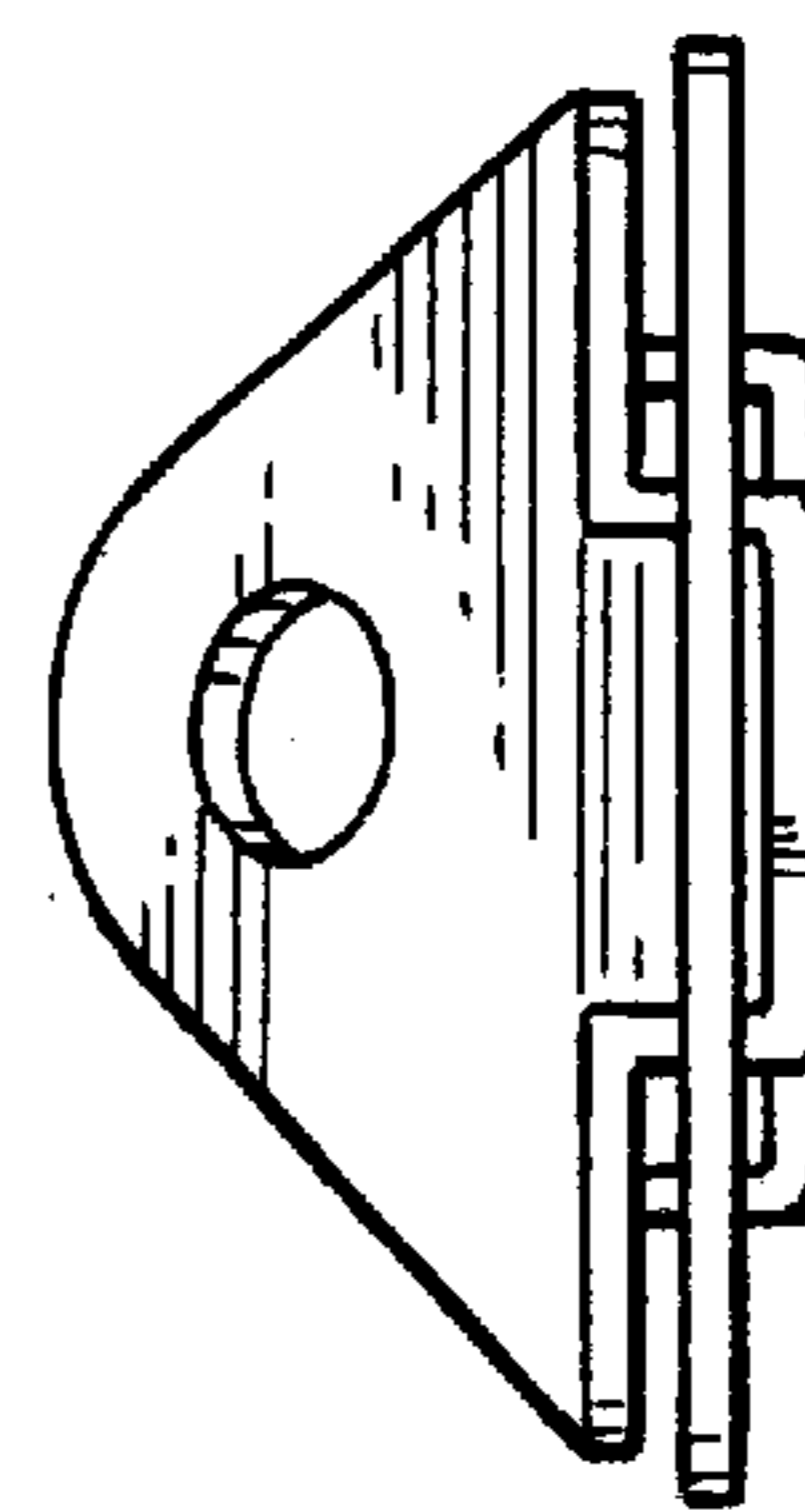

FIG. 7