



US00D450331B1

(12) **United States Design Patent**
Murakami et al.

(10) **Patent No.:** **US D450,331 S**
(45) **Date of Patent:** **** Nov. 13, 2001**

(54) **TRACKED VEHICLE FOR CONSTRUCTION**

OTHER PUBLICATIONS

(75) Inventors: **Yoshiaki Murakami; Shintaro Sakitani; Hirokazu Imashige; Hiroshi Shimokakiuchi**, all of Hiroshima (JP)

U.S. application No. 29/128,802, filed Sep. 1, 2000, Pending.

* cited by examiner

(73) Assignee: **Kobelco Construction Machinery Co., Ltd.**, Hiroshima (JP)

Primary Examiner—Mitchell Siegel

(74) *Attorney, Agent, or Firm*—Oblon, Spivak, McClelland, Maier & Neustadt, P.C.

(**) Term: **14 Years**

(57) **CLAIM**

(21) Appl. No.: **29/128,803**

The ornamental design for a tracked vehicle for construction, as shown and described.

(22) Filed: **Sep. 1, 2000**

(30) **Foreign Application Priority Data**

DESCRIPTION

Mar. 1, 2000 (JP) 12-004296

(51) **LOC (7) Cl.** **12-09**

(52) **U.S. Cl.** **D15/25**

(58) **Field of Search** D15/23-25; 180/9.1, 180/9.2, 89.1, 89.12, 139, 235, 9.62, 14 R; 280/400; 414/694, 698, 699, 722-724

FIG. 1 is a front elevational view of a tracked vehicle for construction showing our design;

FIG. 2 is a rear elevational view thereof;

FIG. 3 is a left side elevational view thereof;

FIG. 4 is a right side elevational view thereof;

FIG. 5 is a top plan view thereof;

FIG. 6 is a bottom plan view thereof;

FIG. 7 is a front elevational view of a second embodiment of a tracked vehicle for construction having transparent windows as illustrated;

FIG. 8 is a rear elevational view thereof;

FIG. 9 is a left side elevational view thereof;

FIG. 10 is a right side elevational view thereof;

FIG. 11 is a top plan view thereof; and,

FIG. 12 is a front elevational view of the first embodiment, the broken line showing of the boom is for illustrative purposes only and forms no part of the claimed design.

(56) **References Cited**

U.S. PATENT DOCUMENTS

- D. 273,384 * 4/1984 Nasu et al. D15/25
- D. 309,313 * 7/1990 Takashima et al. D15/25
- D. 406,152 * 2/1999 Miyaoka et al. D15/25
- D. 409,629 * 5/1999 Miyaoka et al. D15/25
- D. 431,253 * 9/2000 Marchetta et al. D15/25
- D. 432,144 * 10/2000 Kraft et al. D15/25
- D. 432,145 * 10/2000 Kraft et al. D15/25
- D. 433,689 * 11/2000 Kraft et al. D15/25
- D. 436,605 * 1/2001 Shaw et al. D15/25
- D. 440,235 * 4/2001 Kuwae et al. D15/25

1 Claim, 7 Drawing Sheets

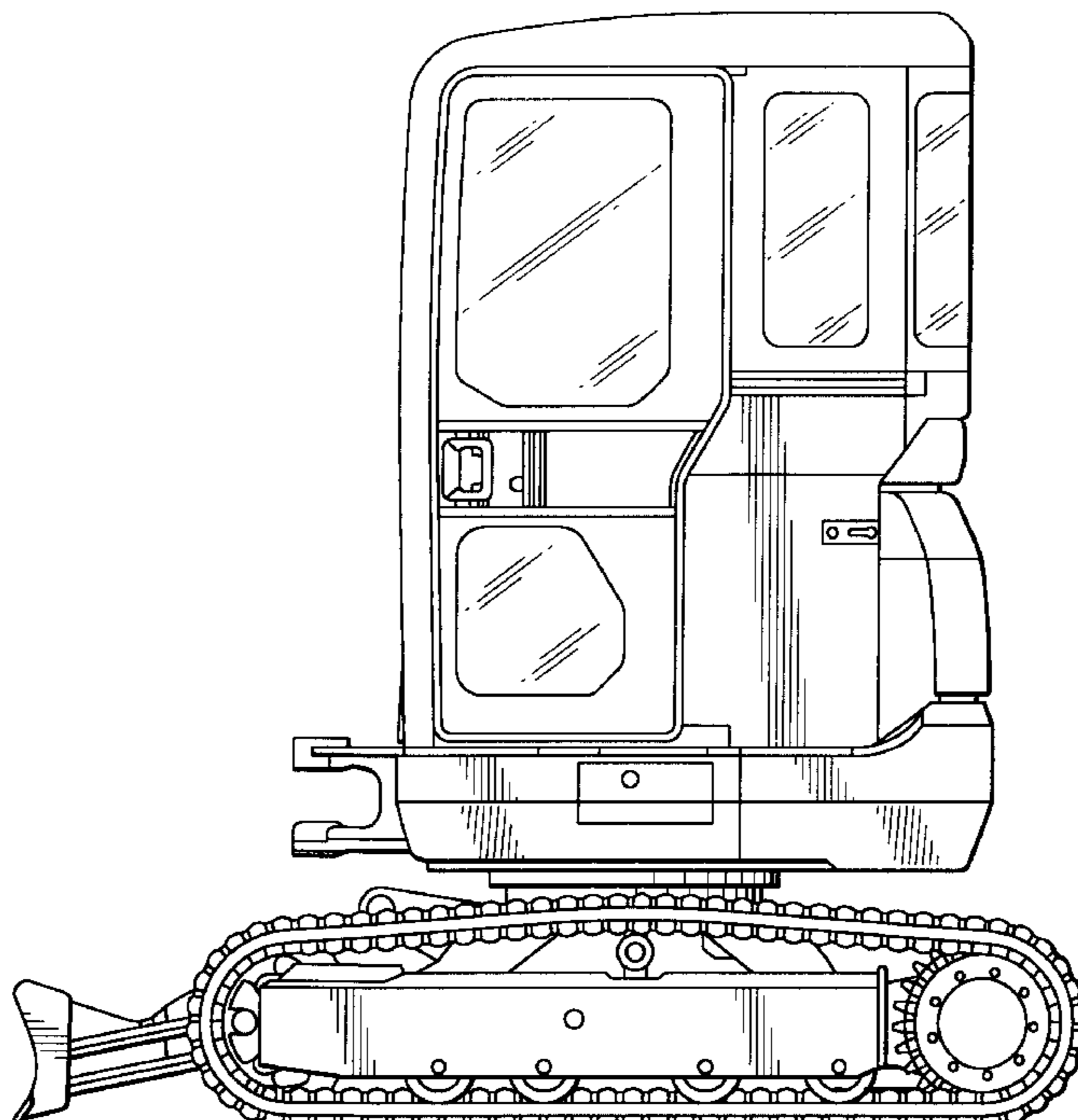

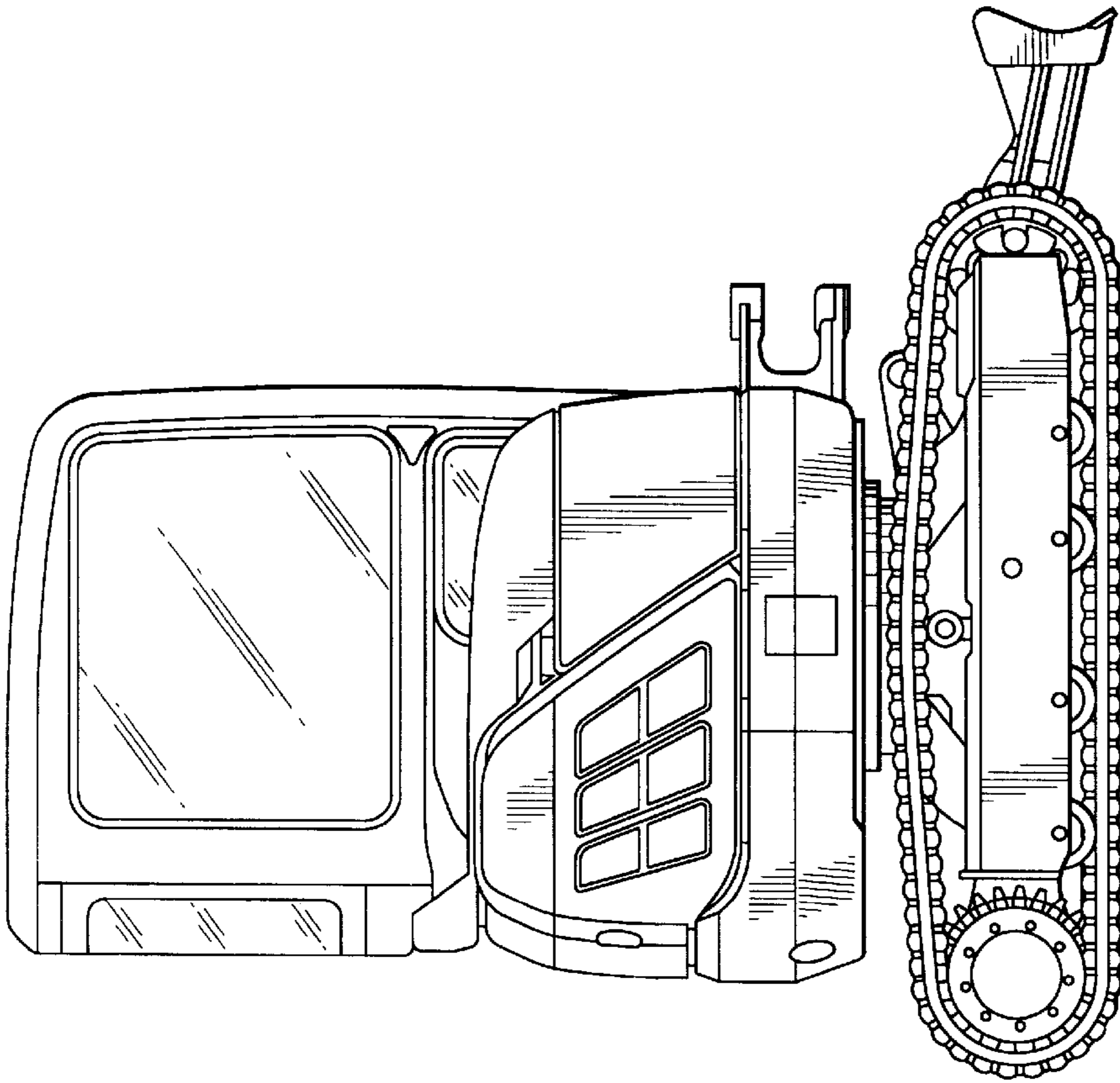

FIG. 2

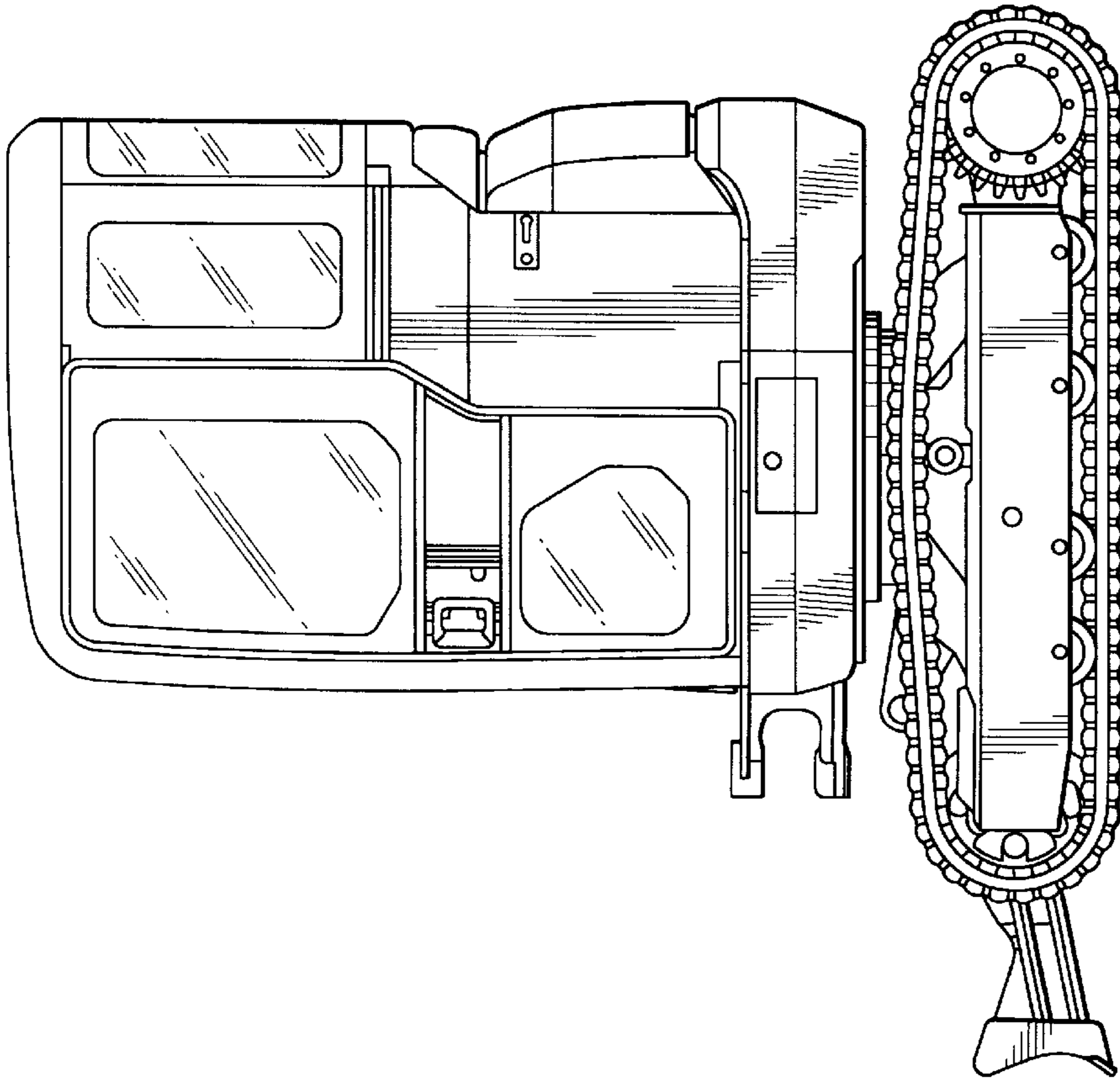

FIG. 1

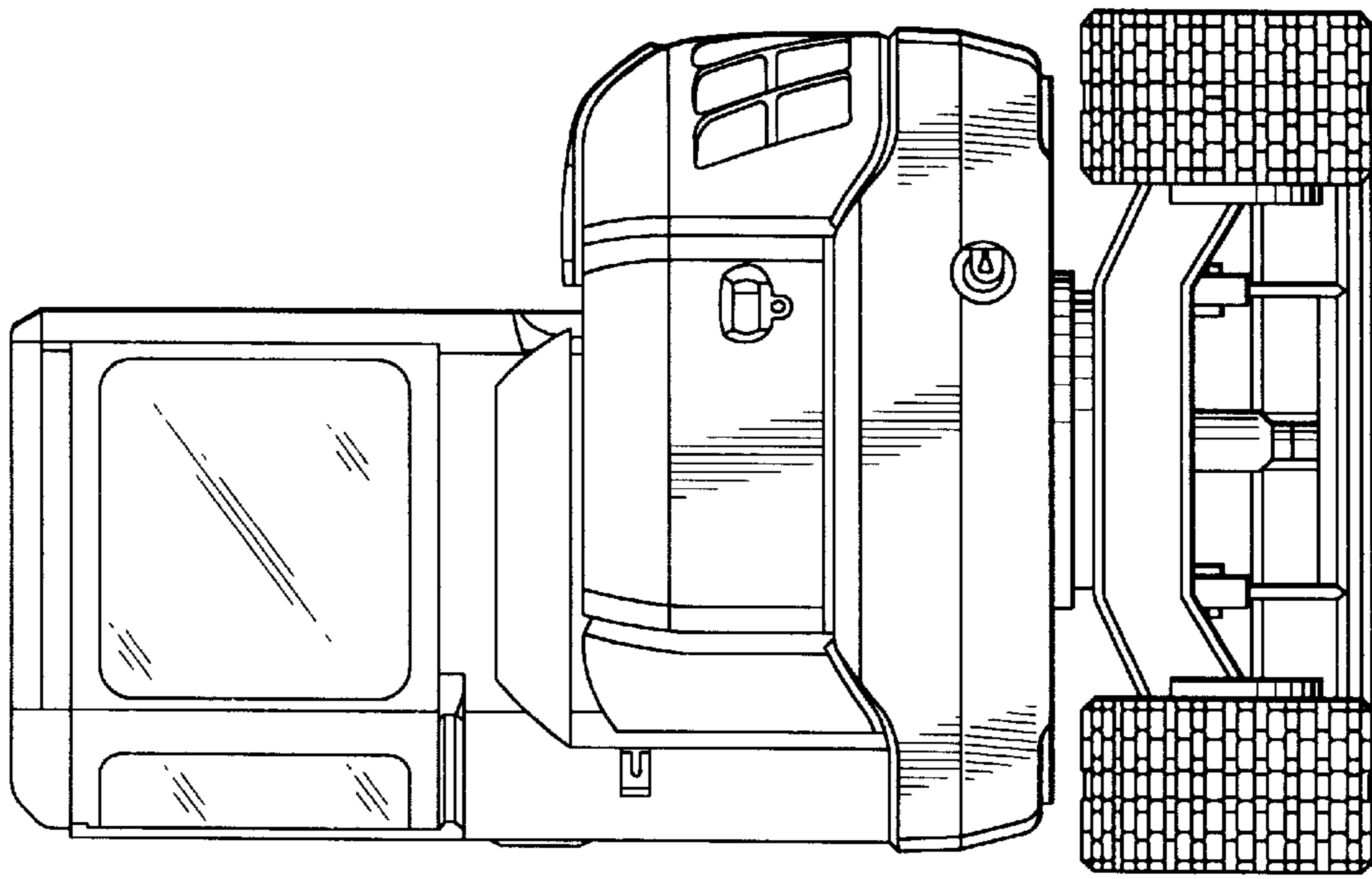

FIG. 4

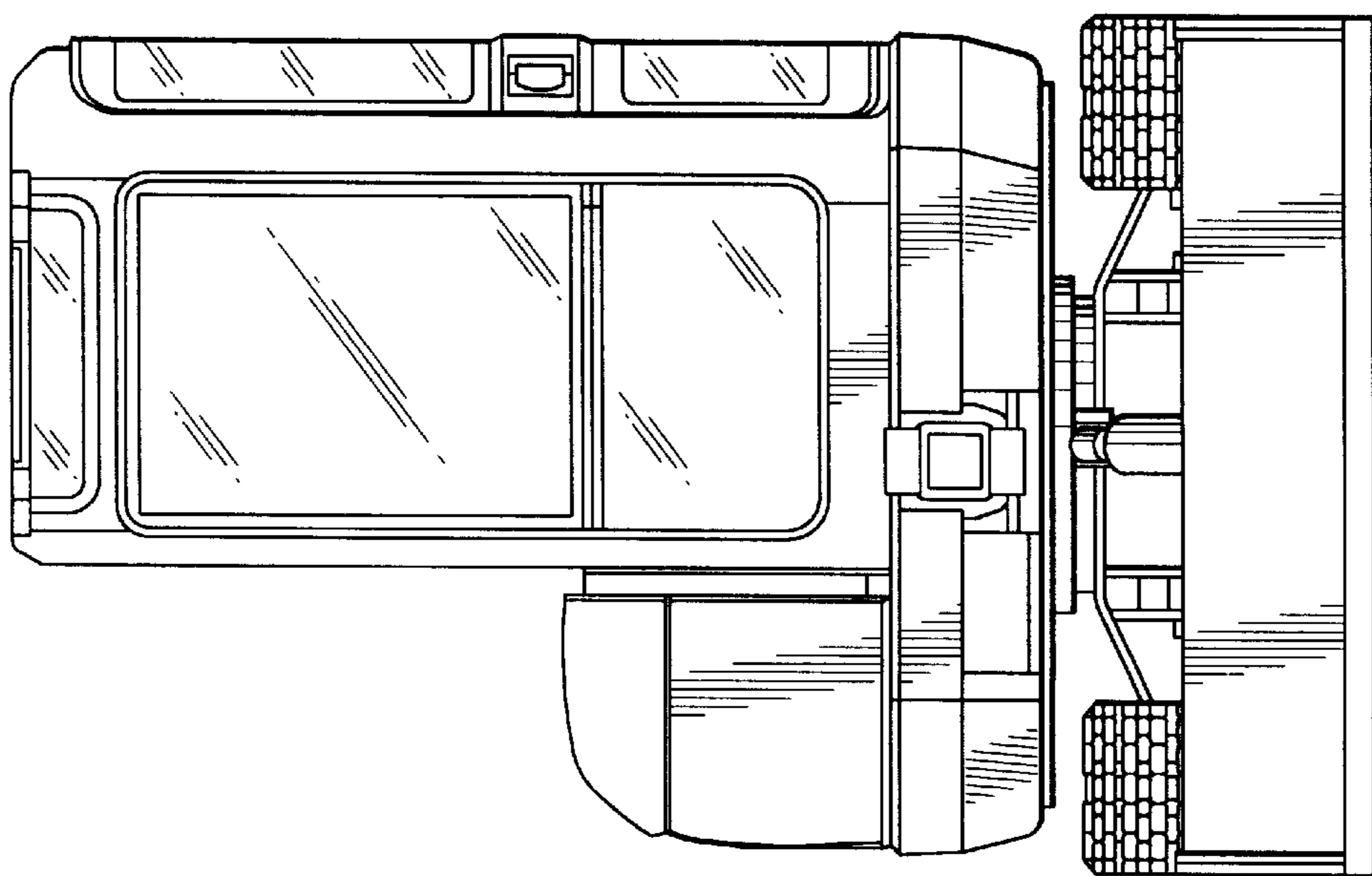

FIG. 3

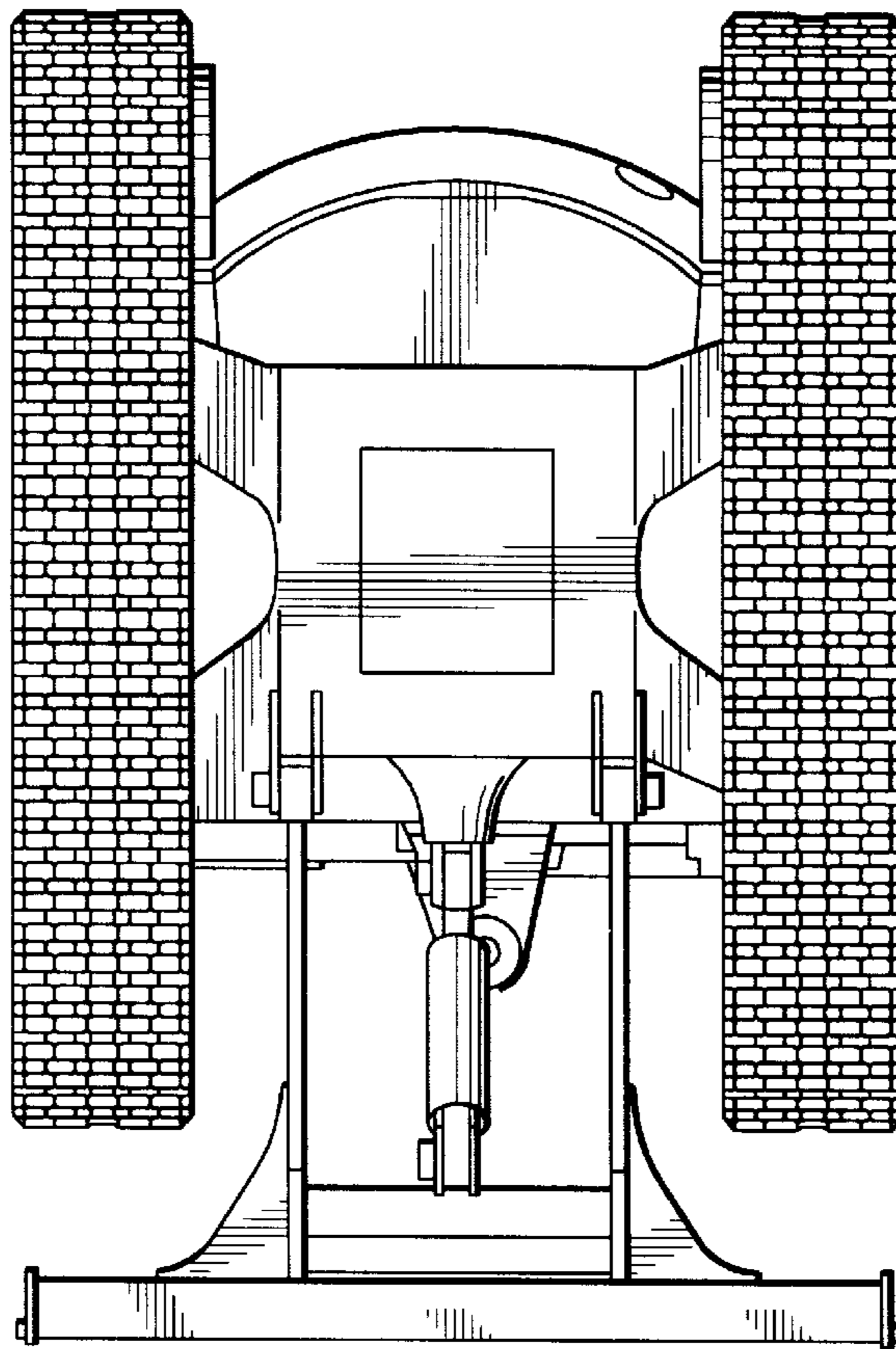

FIG. 6

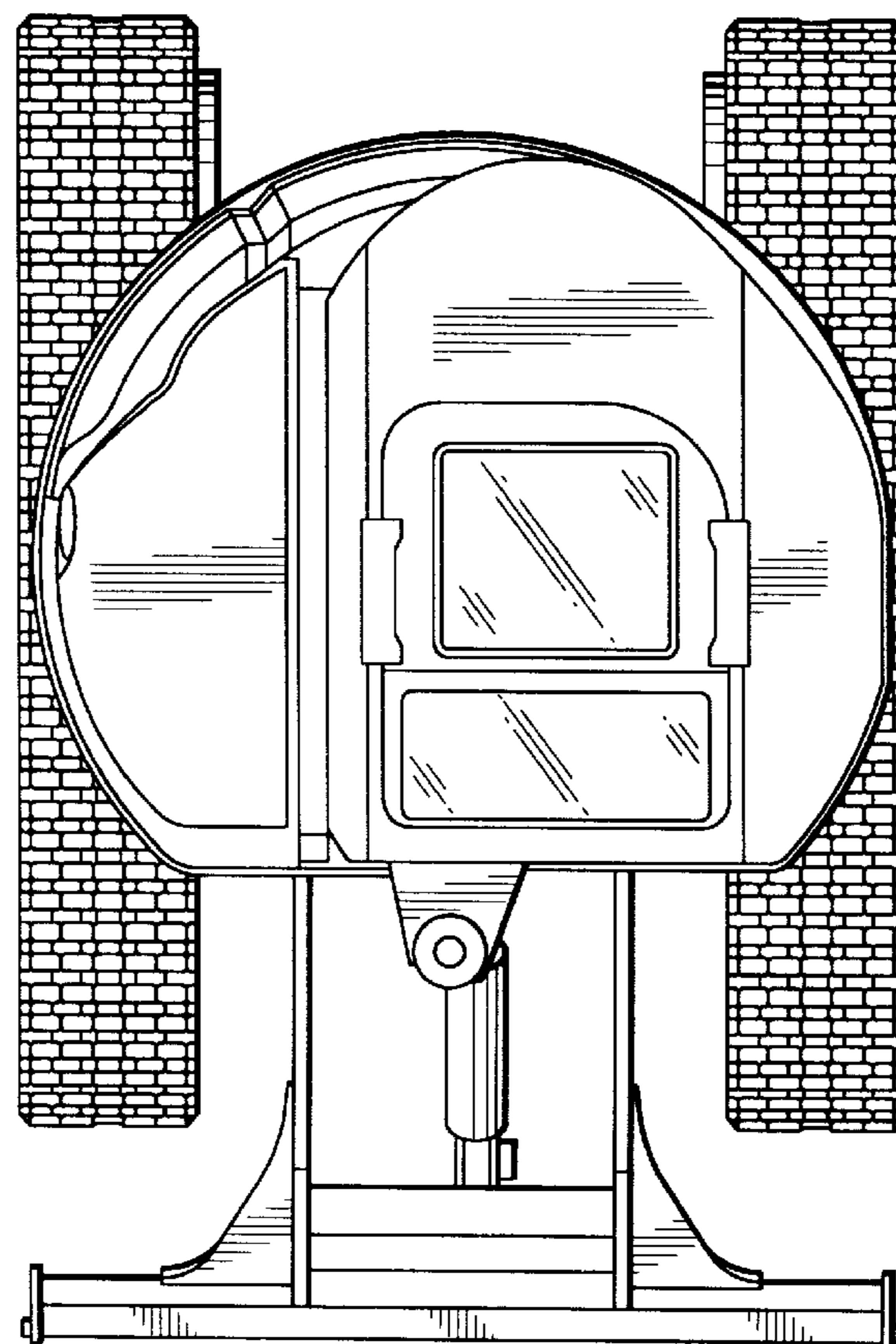

FIG. 5

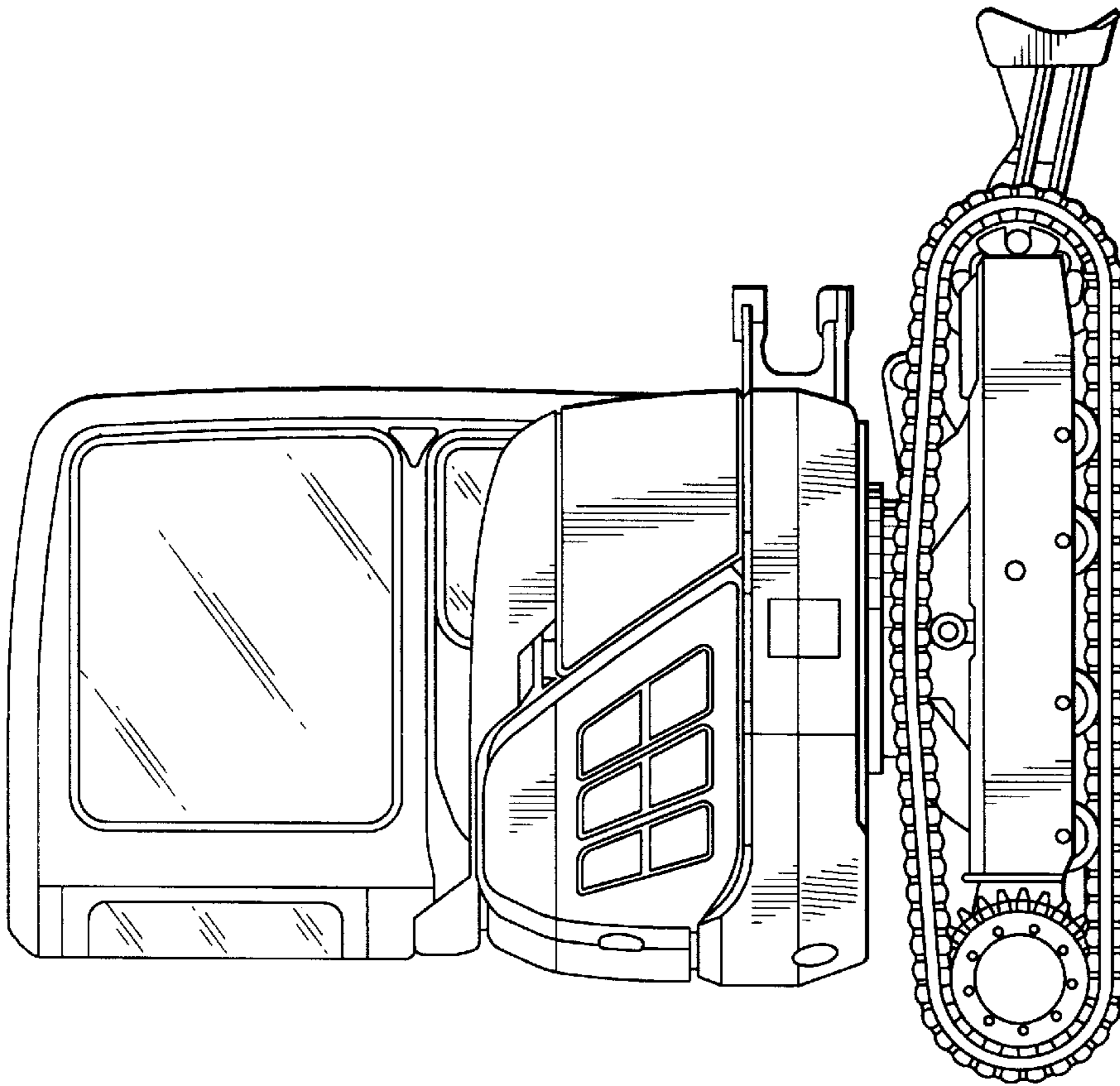

FIG. 7

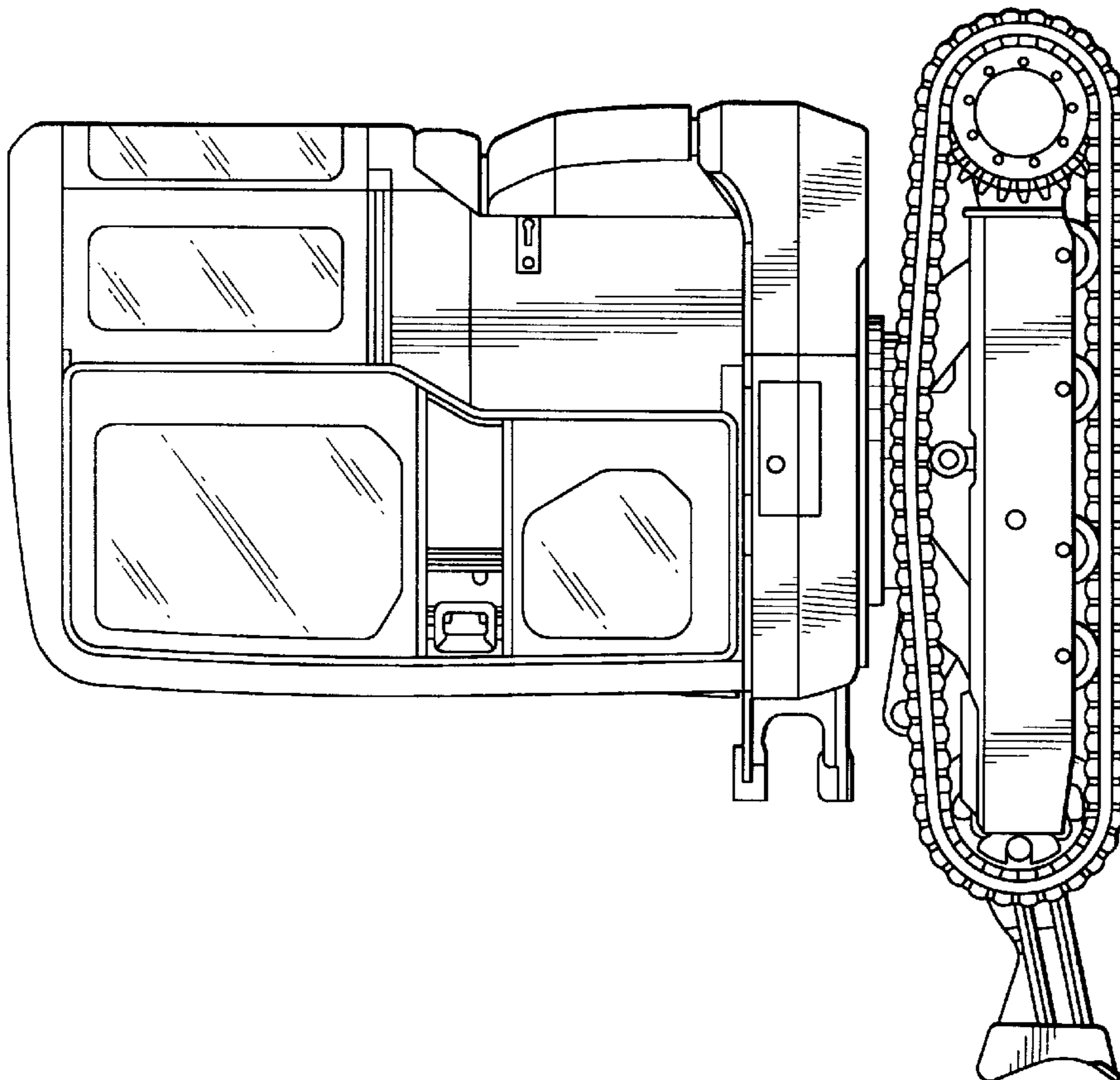

FIG. 8

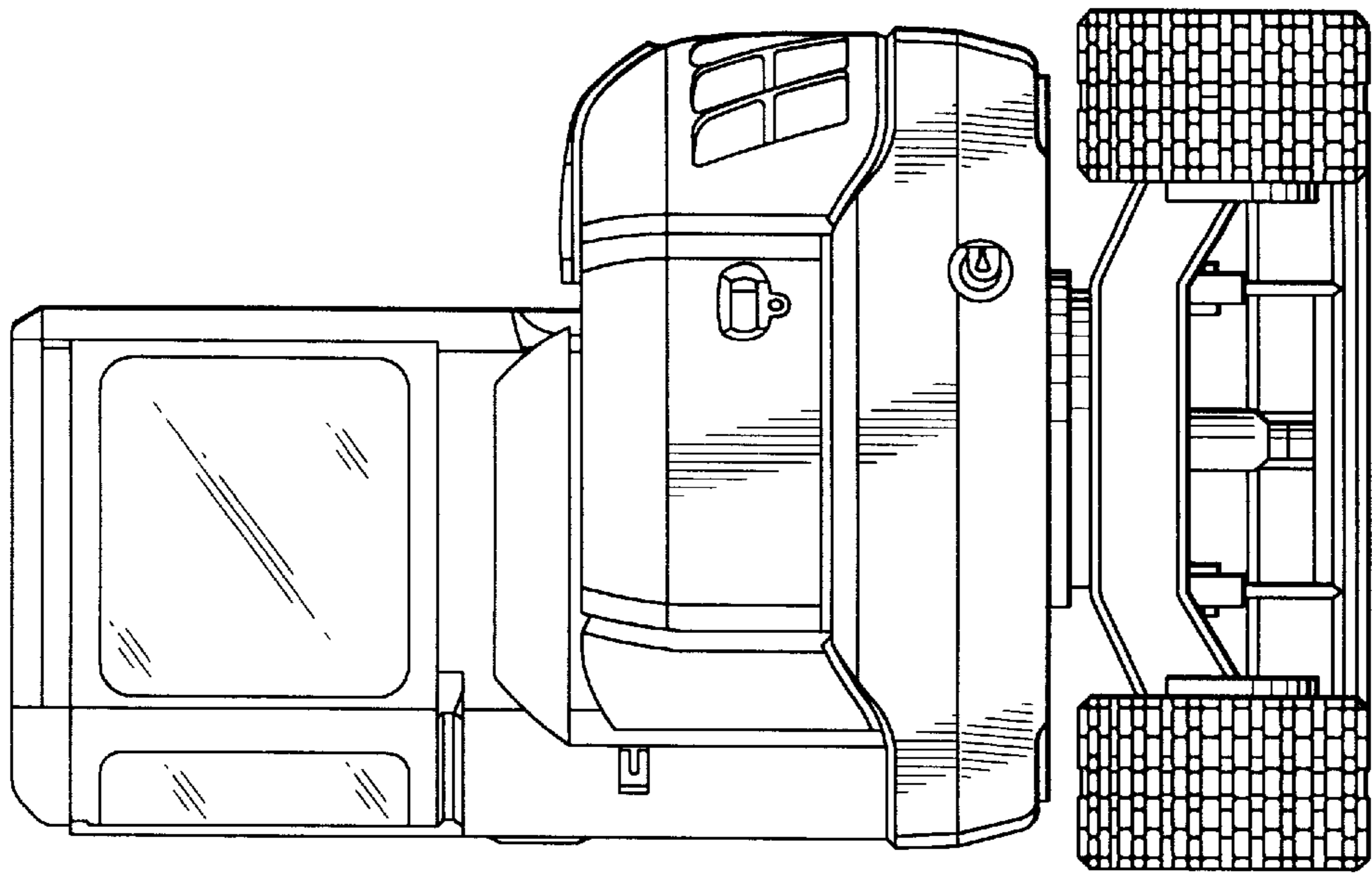

FIG. 9

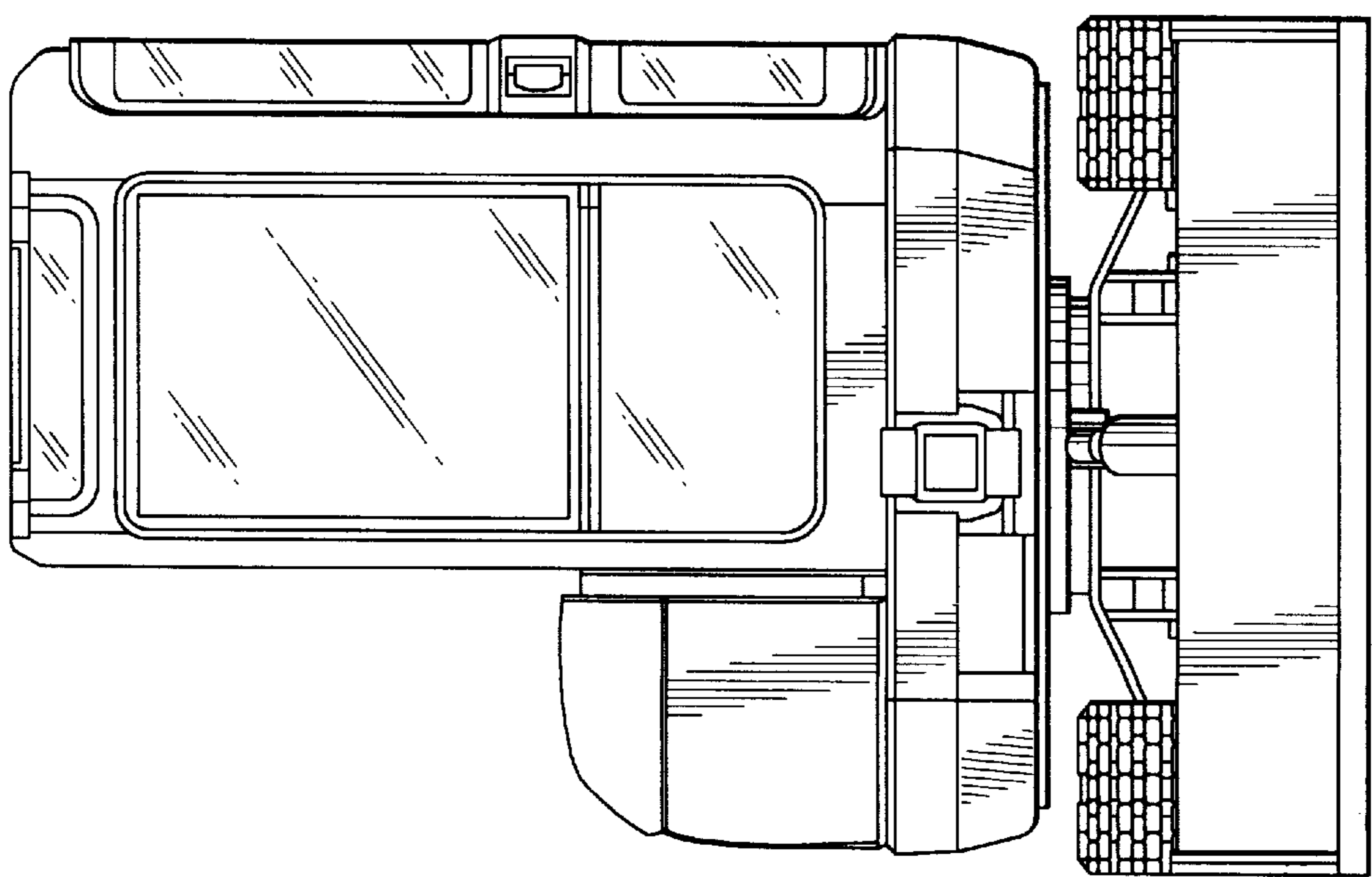

FIG. 10

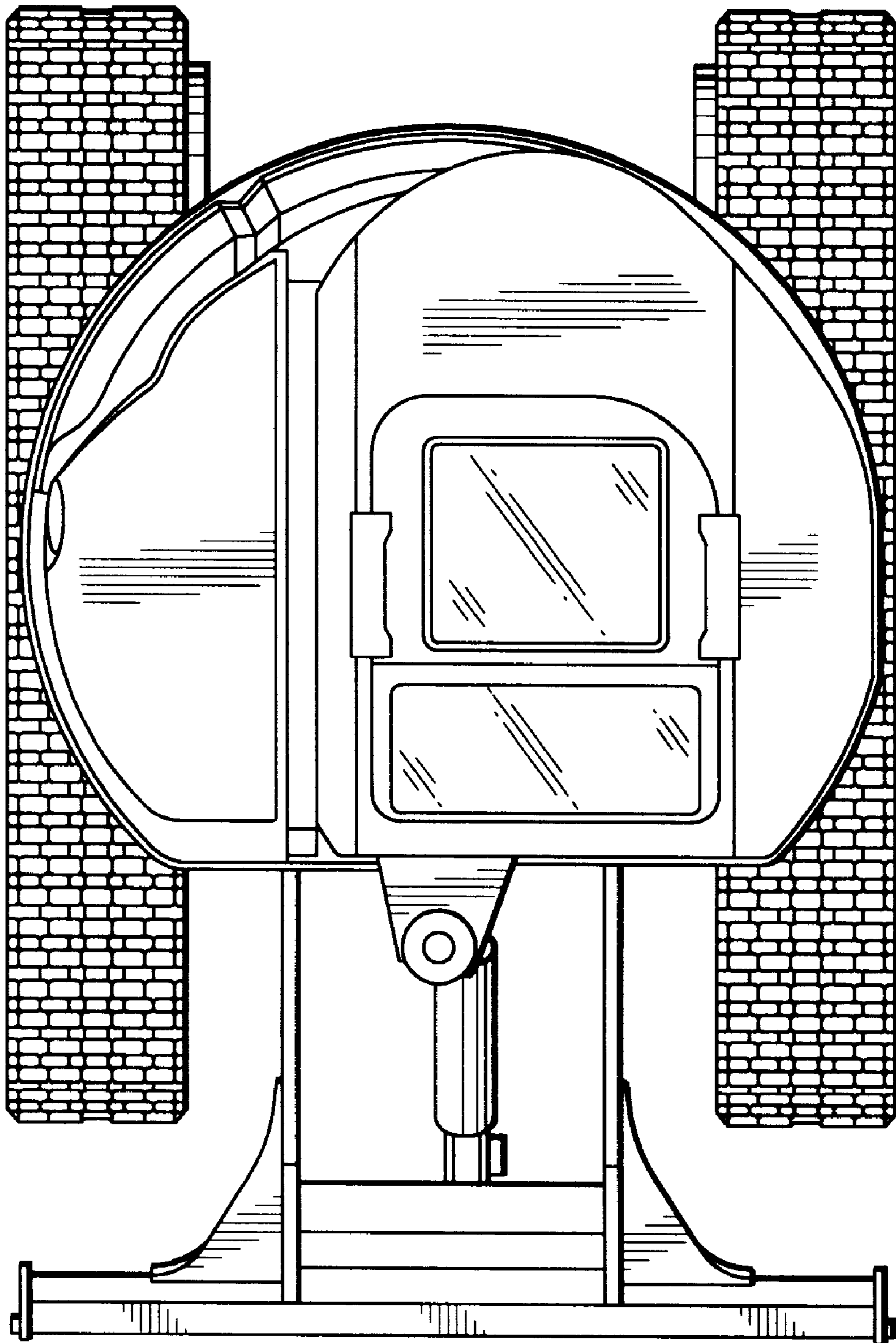

FIG. 11

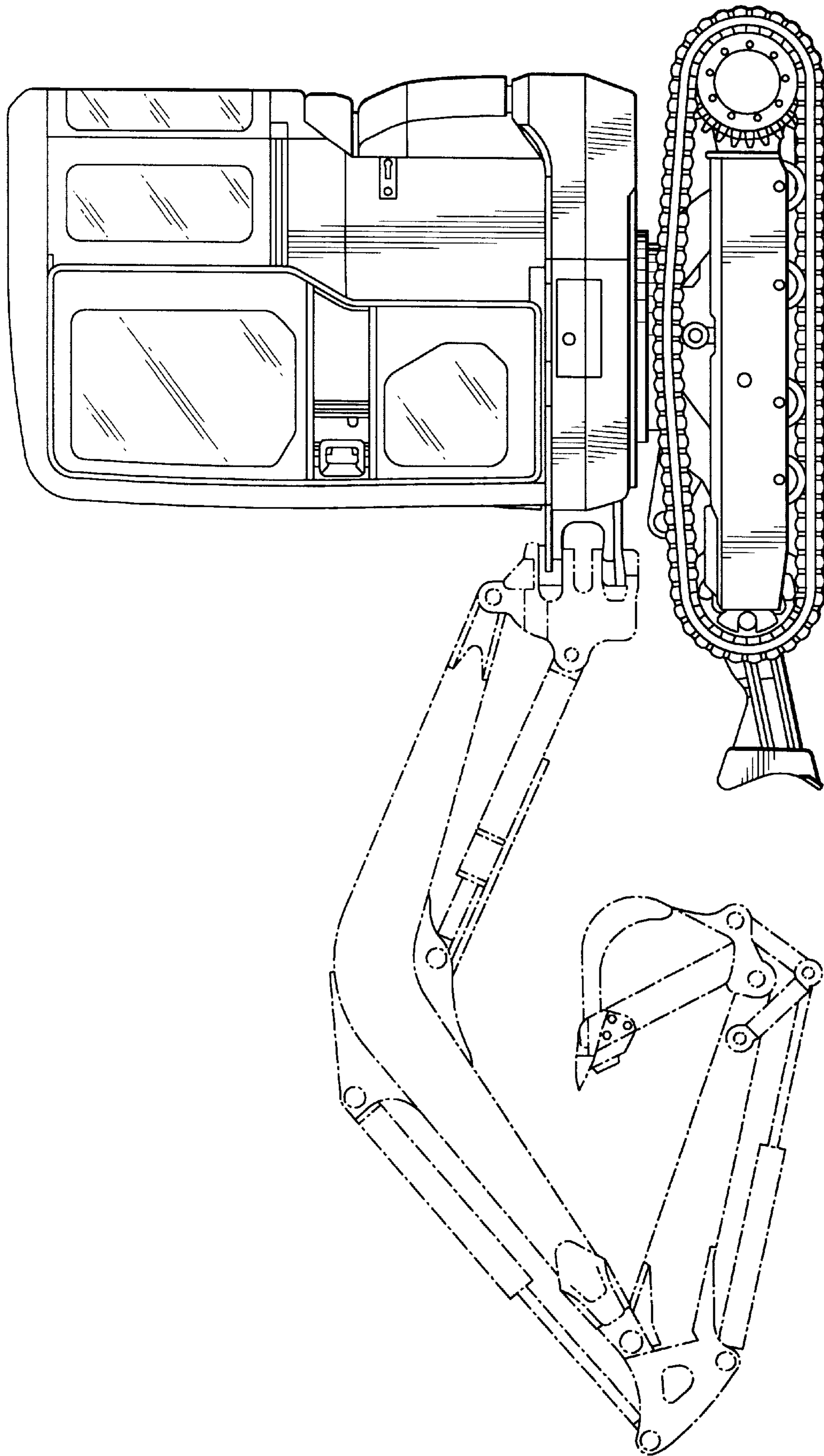

FIG. 12