



US00D450031B1

(12) **United States Design Patent**
Hall

(10) **Patent No.:** **US D450,031 S**

(45) **Date of Patent:** **** Nov. 6, 2001**

(54) **VEHICLE TOP**

5,549,939 * 8/1996 Ray 40/591

* cited by examiner

(76) Inventor: **Timothy P. Hall**, 3108 S. Grant St.,
Englewood, CO (US) 80110

Primary Examiner—Doris V. Coles

Assistant Examiner—T. Chase Nelson

(**) Term: **14 Years**

(74) *Attorney, Agent, or Firm*—Sheridan Ross, P.C.

(21) Appl. No.: **29/112,118**

(57) **CLAIM**

(22) Filed: **Oct. 8, 1999**

The ornamental design for a vehicle top, as shown and described.

(51) **LOC (7) Cl.** **12-16**

DESCRIPTION

(52) **U.S. Cl.** **D12/401**

FIG. 1 is a perspective view of a first embodiment of the vehicle top of this invention, the vehicle top of this invention shown as mounted to a standard passenger type vehicle;

(58) **Field of Search** D12/401, 400,

D12/190, 191; D6/546, 549; D8/363; 296/95.1,

97.1, 97.2, 210; 40/591

FIG. 2 is a top view of FIG. 1;

FIG. 3 is a left side elevation of FIG. 1, the right side elevation being a mirror image;

(56) **References Cited**

U.S. PATENT DOCUMENTS

D. 190,420 * 5/1961 Wood D12/401

D. 190,565 * 6/1961 Wood D12/401

D. 402,621 * 12/1998 Douglas D12/401

D. 409,541 * 5/1999 Sproull et al. D12/191

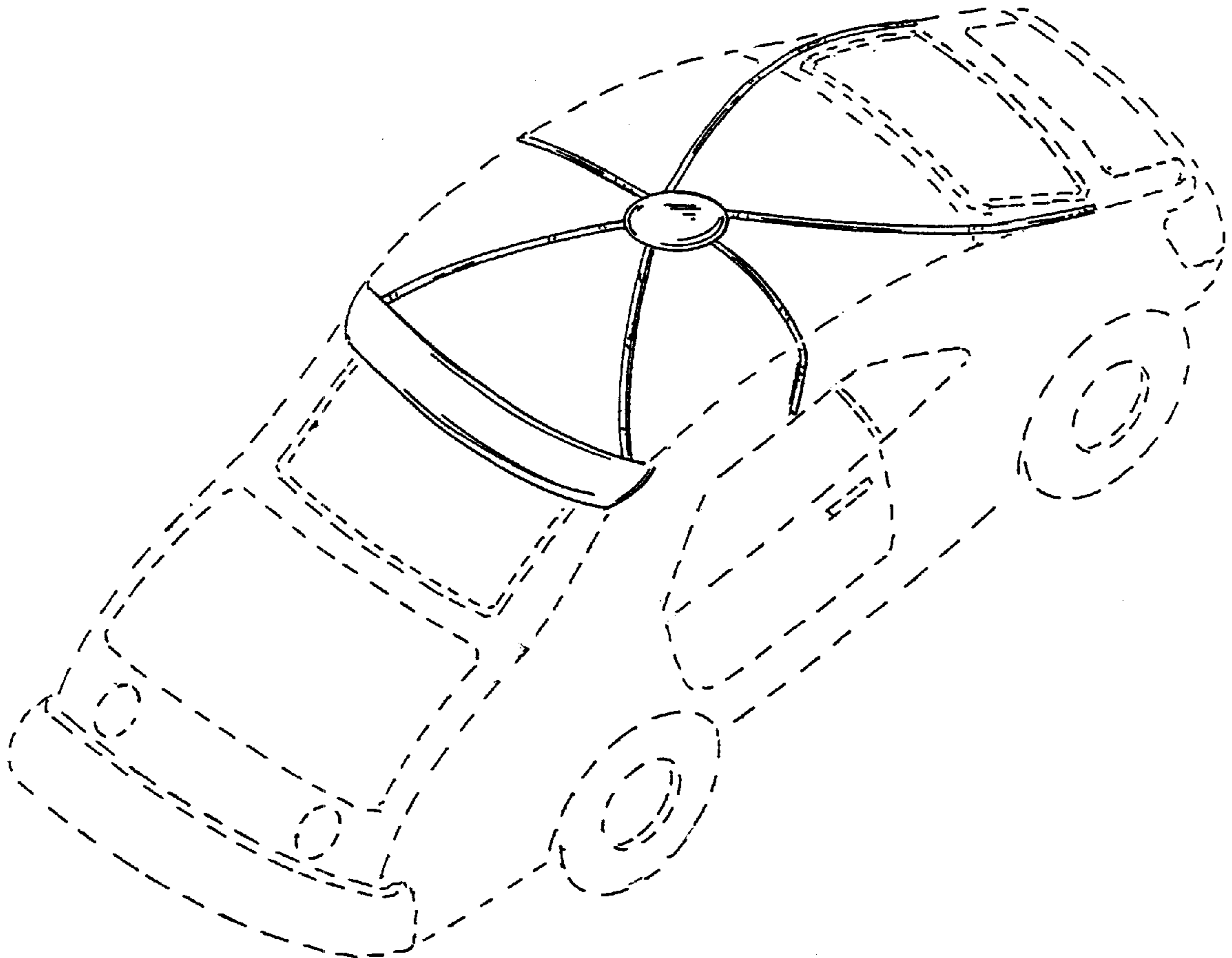
2,665,140 * 1/1954 Krusemark 296/95.1

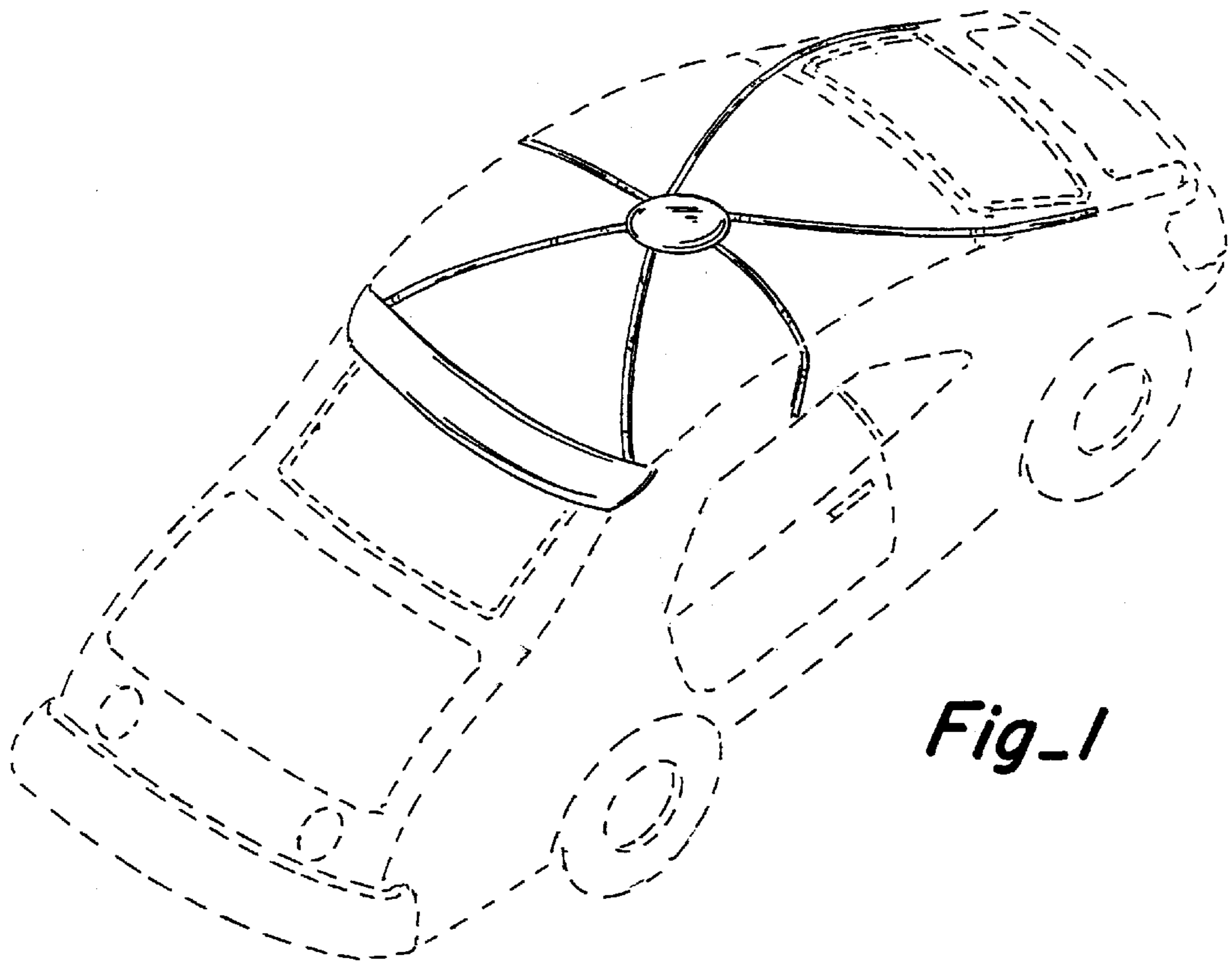
FIG. 4 is a front view of FIG. 1; and,

FIG. 5 is a rear view of FIG. 1.

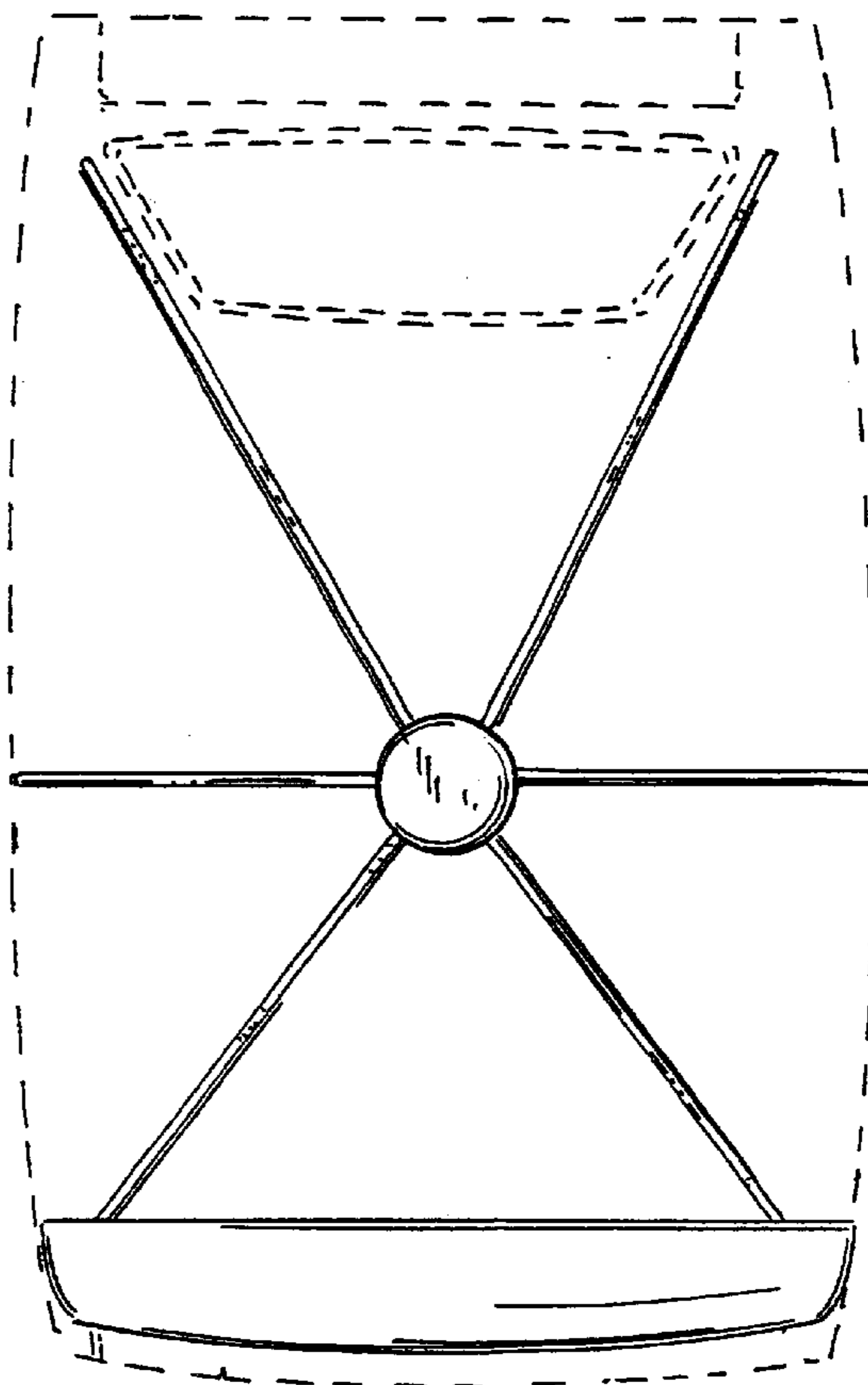
The parts of the vehicles depicted by means of broken lines in the Figures have been shown for illustrative purposes only and form no part of the claimed design.

1 Claim, 2 Drawing Sheets

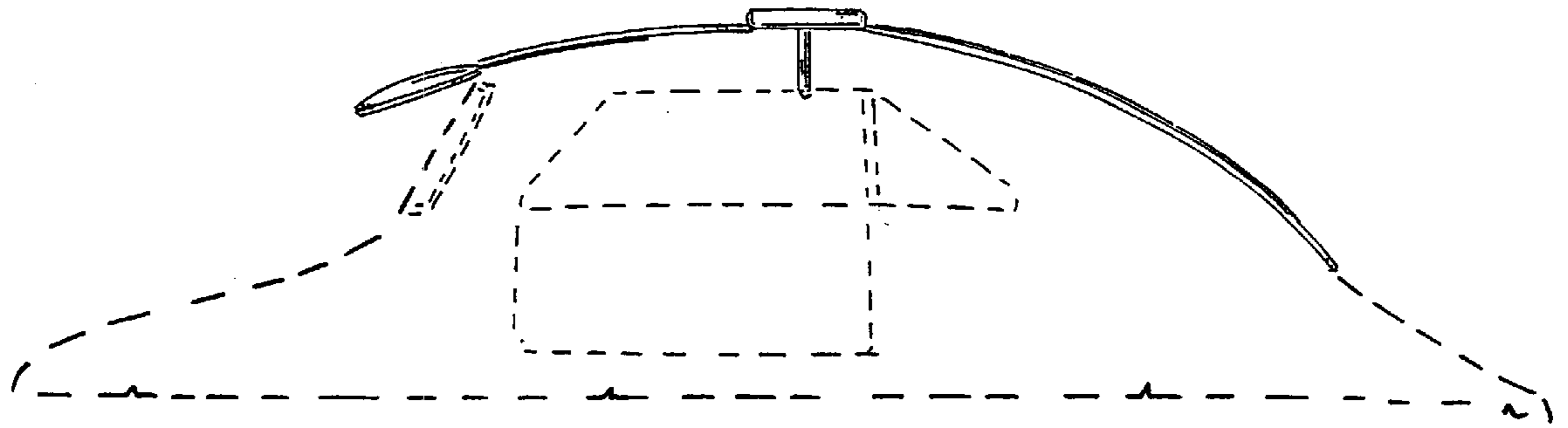




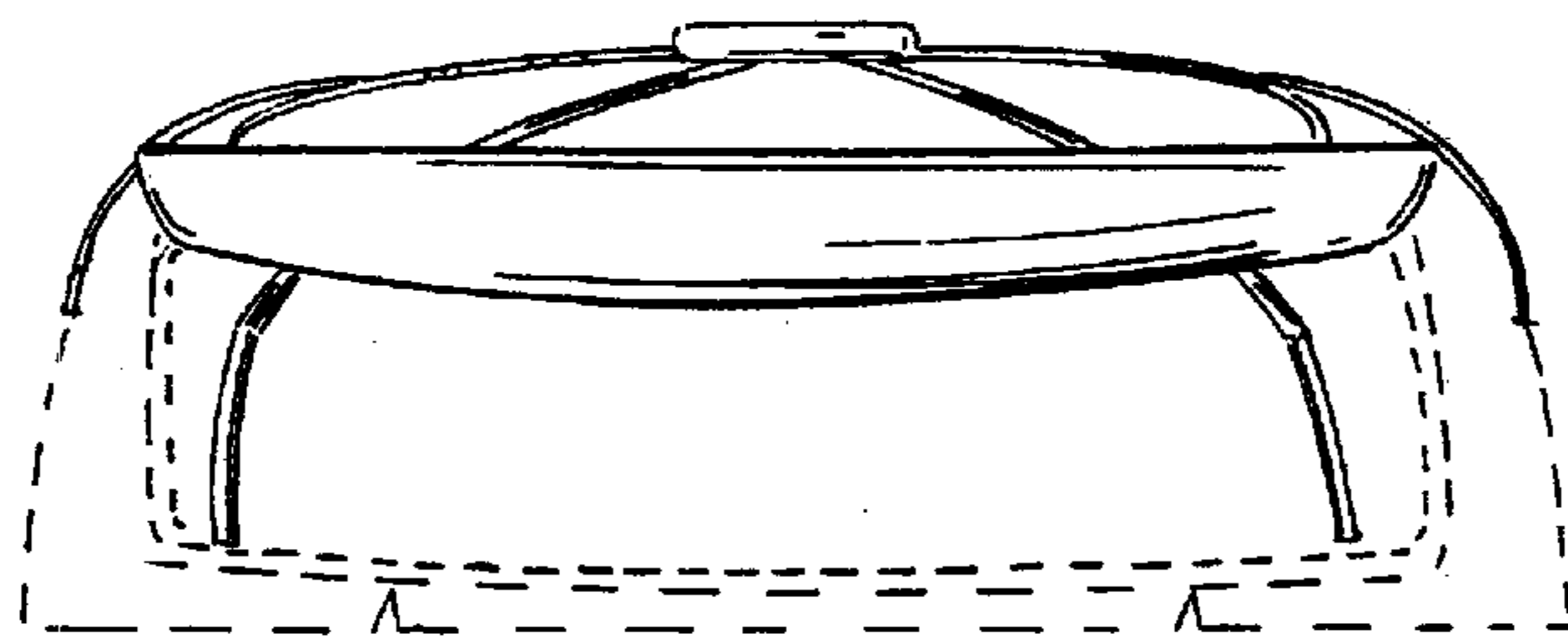
Fig_1



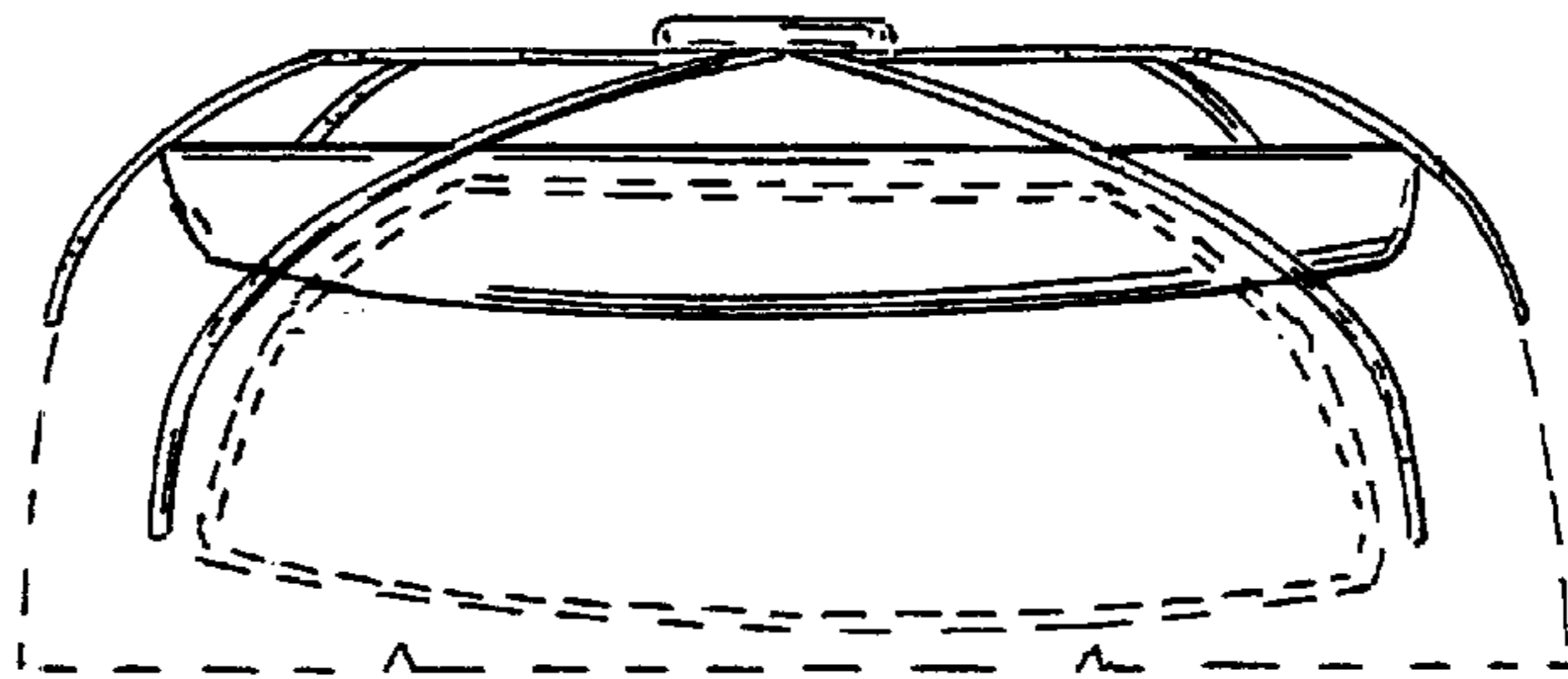
Fig_2



Fig_3



Fig_4



Fig_5