



US00D450021B1

(12) **United States Design Patent**  
**Kemp, Jr.**

(10) **Patent No.:** **US D450,021 S**

(45) **Date of Patent:** **\*\* Nov. 6, 2001**

(54) **TIRE SIDEWALL**

(75) **Inventor:** **Preston Butler Kemp, Jr., Greenville, SC (US)**

(73) **Assignee:** **Michelin Recherche et Technique S.A. (CH)**

(\*\*) **Term:** **14 Years**

(21) **Appl. No.:** **29/135,200**

(22) **Filed:** **Jan. 4, 2001**

(51) **LOC (7) Cl.** ..... **12-15**

(52) **U.S. Cl.** ..... **D12/152**

(58) **Field of Search** ..... D12/134-152;  
152/209.1, 209.9, 209.16, 209.25, 209.27,  
523, 524, 902, 903

(56) **References Cited**

**U.S. PATENT DOCUMENTS**

D. 186,095	9/1959	Balmer et al. ....	D90/20
D. 191,041 *	8/1961	Lauve .....	D12/135
D. 204,862	5/1966	Blankenship et al. ....	D90/20
D. 222,215	10/1971	Munoz .....	D90/20
D. 222,216	10/1971	Overstreet et al. ....	D90/20
D. 265,813	8/1982	Sladky .....	D12/152

D. 301,251 *	5/1989	Tatsumi .....	D12/149
D. 316,689 *	5/1991	Fujuki .....	D12/140
D. 362,223	9/1995	Attinello et al. ....	D12/152
D. 369,769 *	5/1996	Attinello et al. ....	D12/152

\* cited by examiner

*Primary Examiner*—Robert M. Spear

(74) *Attorney, Agent, or Firm*—Martin Farrell; Robert R. Reed; Alan A. Csontos

(57) **CLAIM**

The ornamental design for a tire sidewall, as shown and described.

**DESCRIPTION**

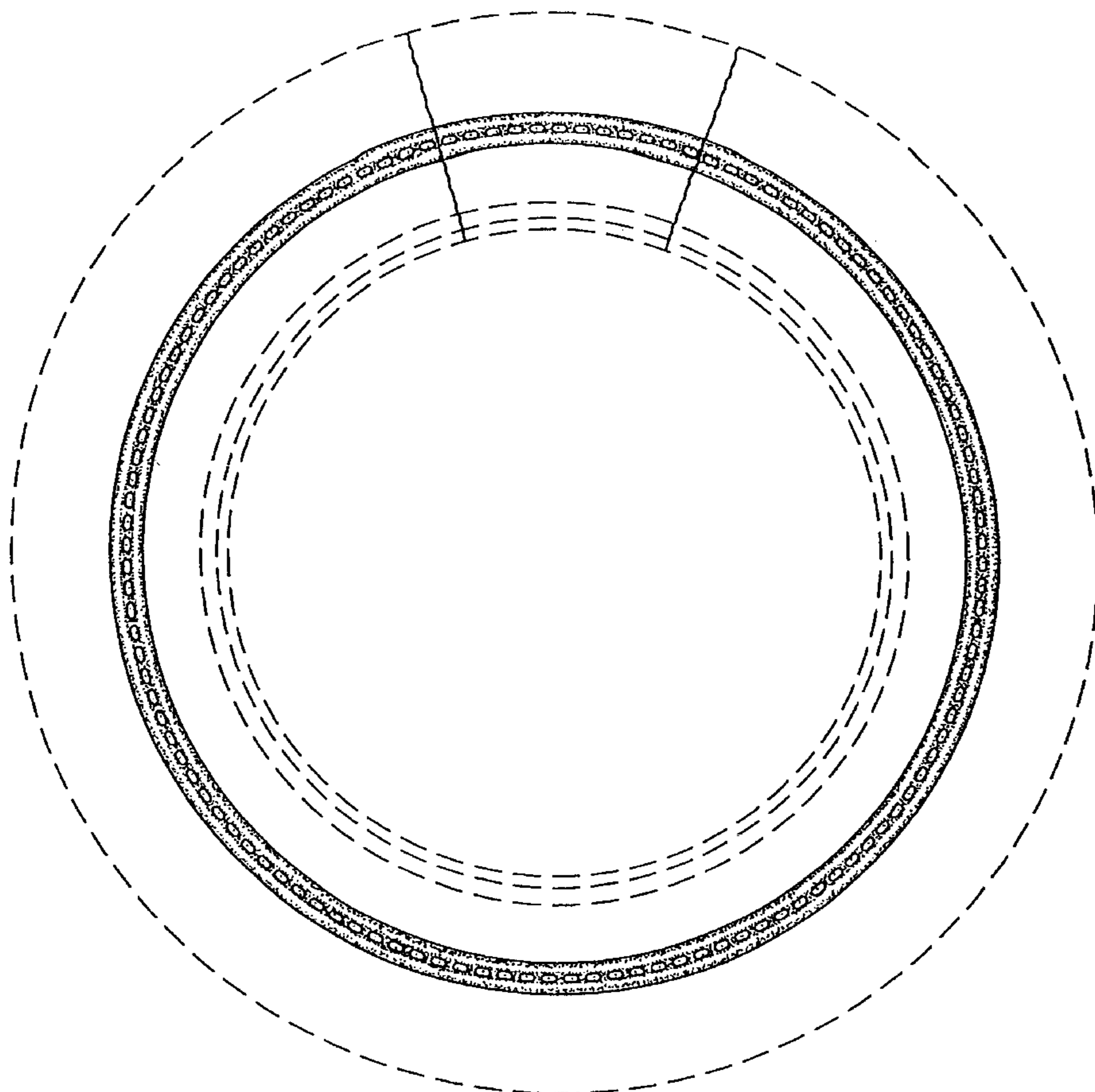
FIG. 1 is a perspective view of a tire sidewall showing my new design;

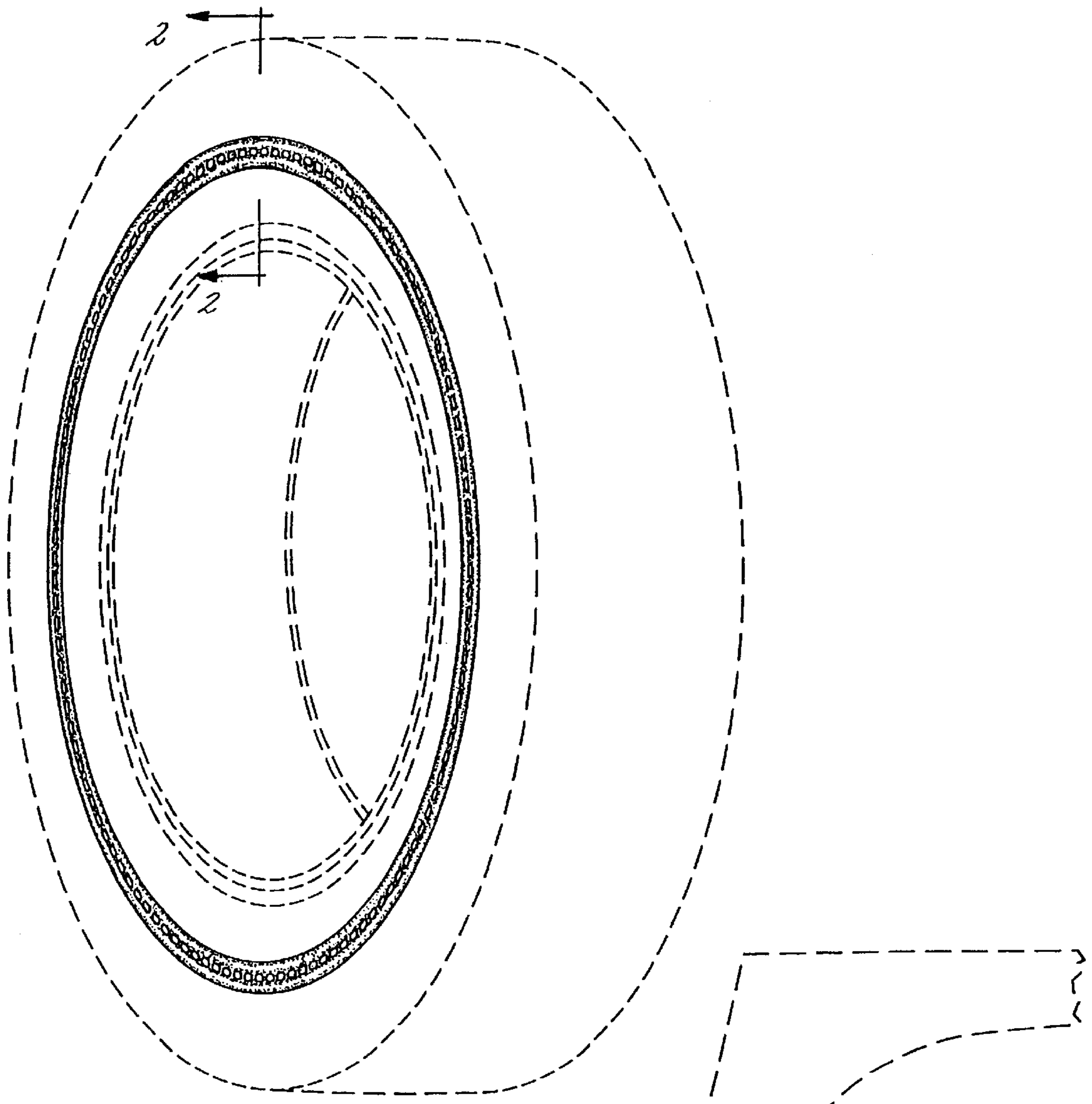
FIG. 2 is an enlarged fragmentary cross-sectional view taken along line 2—2 in FIG. 1 thereof.

FIG. 3 is a side elevation view showing the new design of the tire sidewall of FIG. 1 thereof; and,

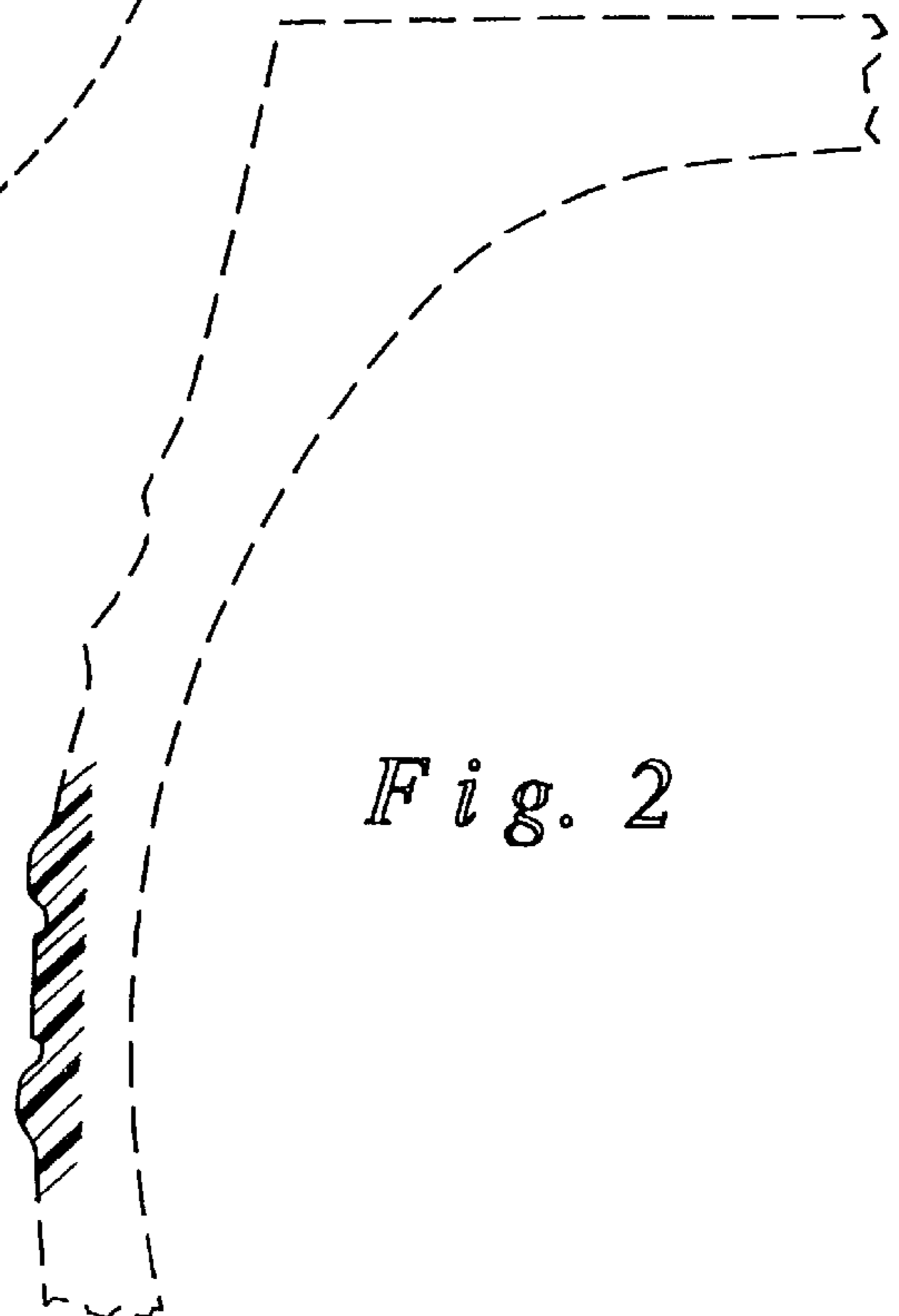
FIG. 4 is an enlarged fragmentary view of FIG. 3 thereof. The broken line disclosure of the tire tread, shoulder and inner bead is for illustrative purposes only and forms no part of the claimed design.

**1 Claim, 2 Drawing Sheets**

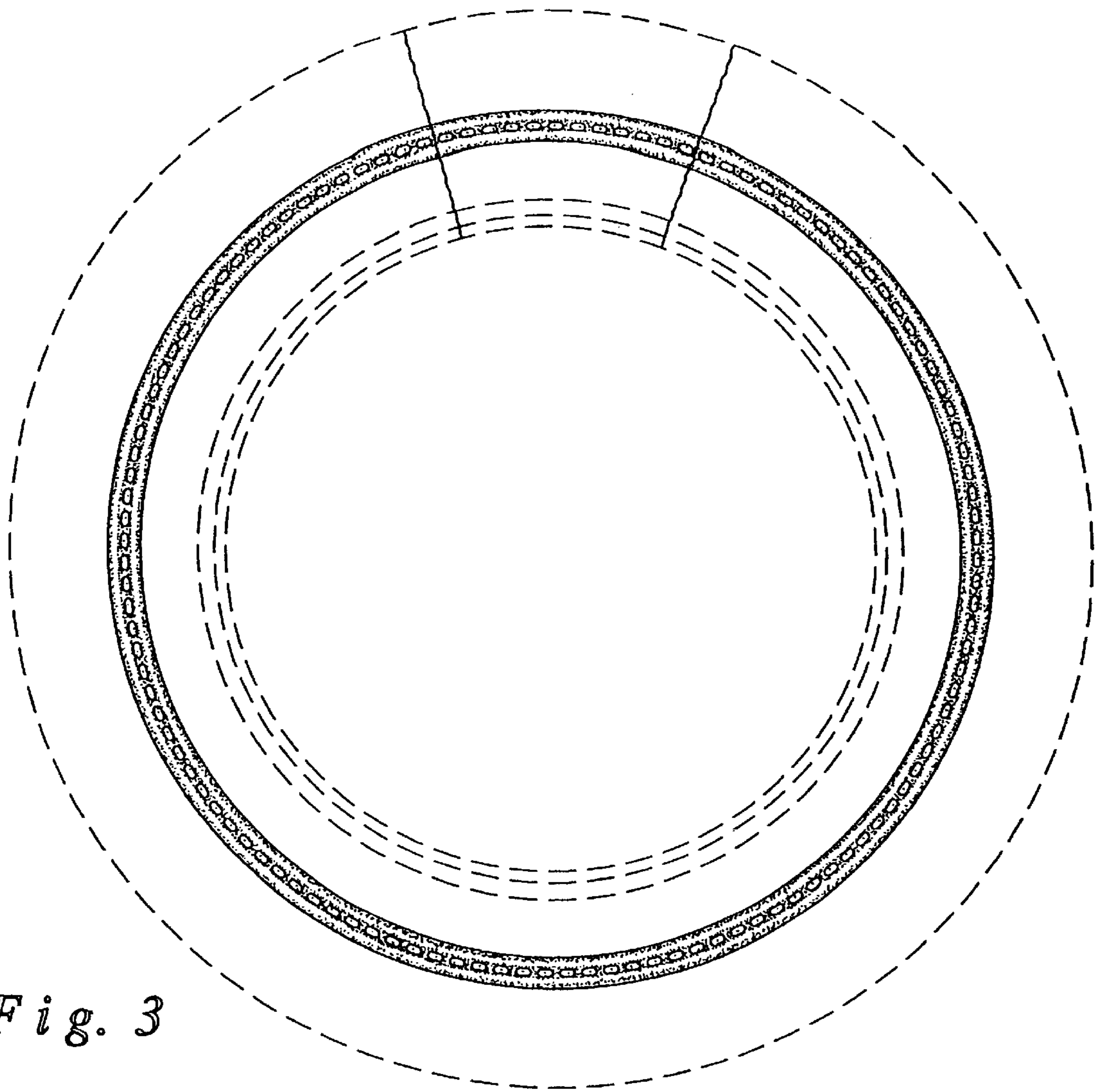




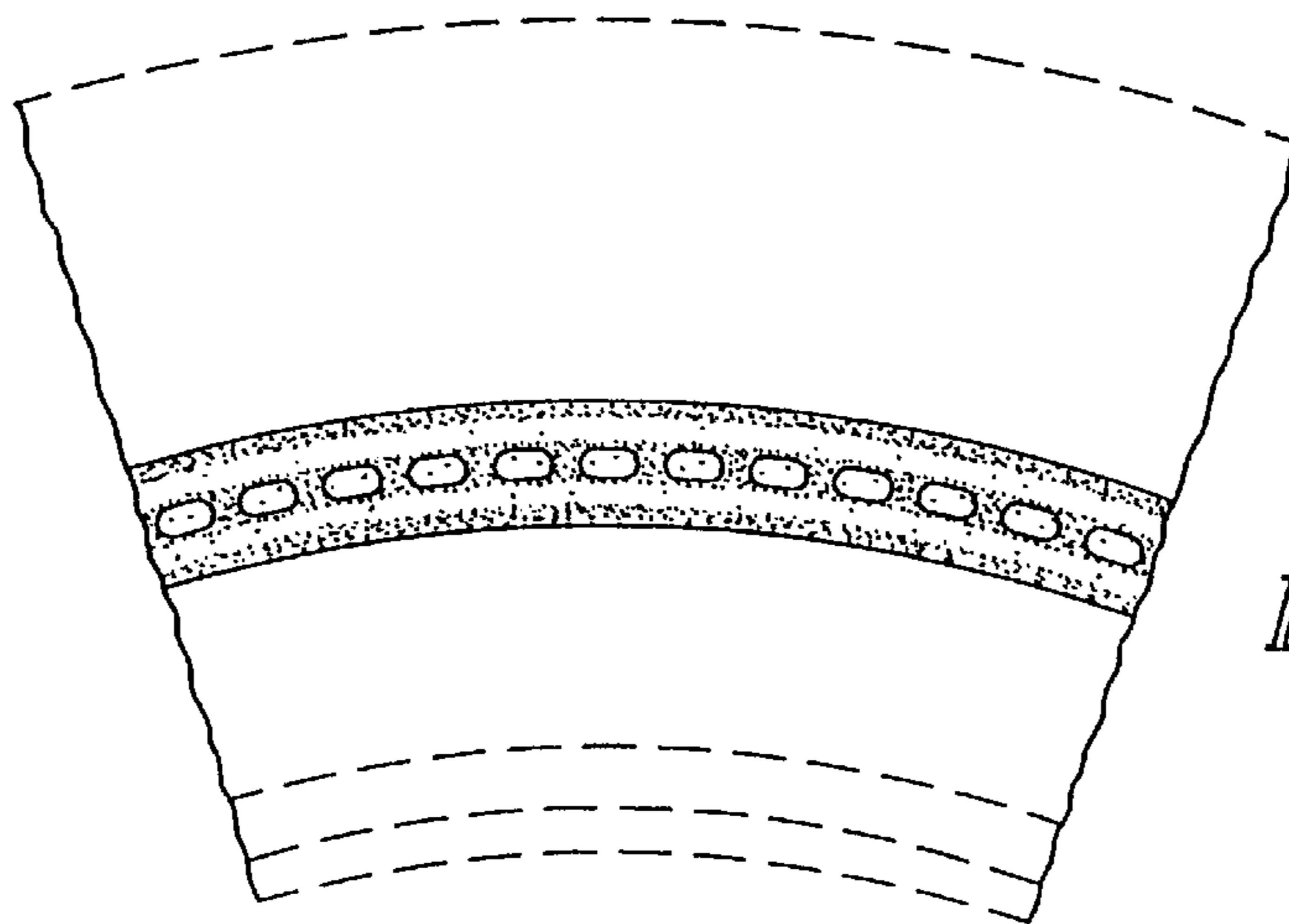
*Fig. 1*



*Fig. 2*



*Fig. 3*



*Fig. 4*