



US00D450016B1

(12) **United States Design Patent**
Bulger

(10) **Patent No.:** **US D450,016 S**

(45) **Date of Patent:** **** Nov. 6, 2001**

(54) **CALIPER INSERT FOR MOTORCYCLES**

(76) **Inventor:** **George F. Bulger**, 45 Manchester Rd.,
Eastchester, NY (US) 10709

(**) **Term:** **14 Years**

(21) **Appl. No.:** **29/126,147**

(22) **Filed:** **Jul. 10, 2000**

(51) **LOC (7) Cl.** **12-11**

(52) **U.S. Cl.** **D12/126**

(58) **Field of Search** D12/110, 114,
D12/126, 174, 179; 180/219, 370; 188/24.11,
18 A, 73.31, 218 A, 344; 280/288.4

(56) **References Cited**

U.S. PATENT DOCUMENTS

- D. 291,189 * 8/1987 Stahel D12/126
- D. 377,774 * 2/1997 Davidson et al. D12/126

OTHER PUBLICATIONS

Drag Specialties Fat Book, caliper inserts on p. 518, 1999.*
Harley-Davidson® Genuine Motor Accessories and Genuine Motor Parts catalog, caliper inserts on p. 334, 2001.*

* cited by examiner

Primary Examiner—Alan P. Douglas

Assistant Examiner—Linda Brooks

(74) *Attorney, Agent, or Firm*—Scully, Scott, Murphy & Presser

(57) **CLAIM**

The ornamental design for a caliper insert for motorcycles, as shown and described.

DESCRIPTION

FIG. 1 is a perspective view of a first embodiment showing my new and ornamental design;
 FIG. 2 is a top plan view thereof;
 FIG. 3 is a bottom plan view thereof;
 FIG. 4 is a front view thereof;
 FIG. 5 is an opposite side view thereof;
 FIG. 6 is an end view thereof, the opposite end being a mirror-image;
 FIG. 7 is a sectional view taken along line 7—7 in FIG. 2;
 FIG. 8 is a perspective view of a second embodiment for a caliper insert for motorcycles showing my new and ornamental design,
 FIG. 9 is a top plan view thereof;
 FIG. 10 is a bottom plan view thereof;
 FIG. 11 is a front view thereof;
 FIG. 12 is a rear view thereof;
 FIG. 13 is an end view thereof, the opposite end being a mirror-image; and,
 FIG. 14 is a sectional view taken along line 14—14 in FIG. 9.

1 Claim, 2 Drawing Sheets

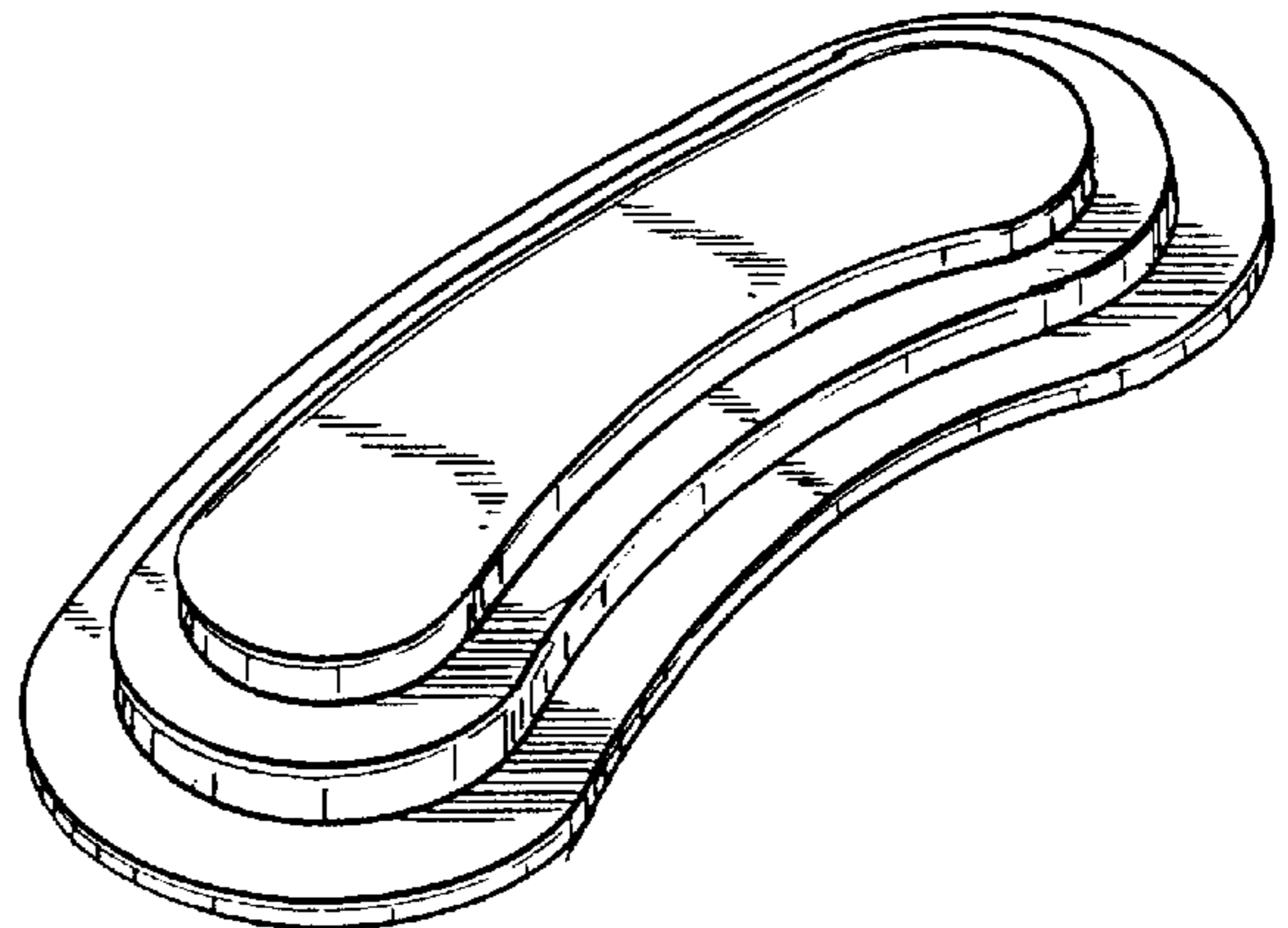
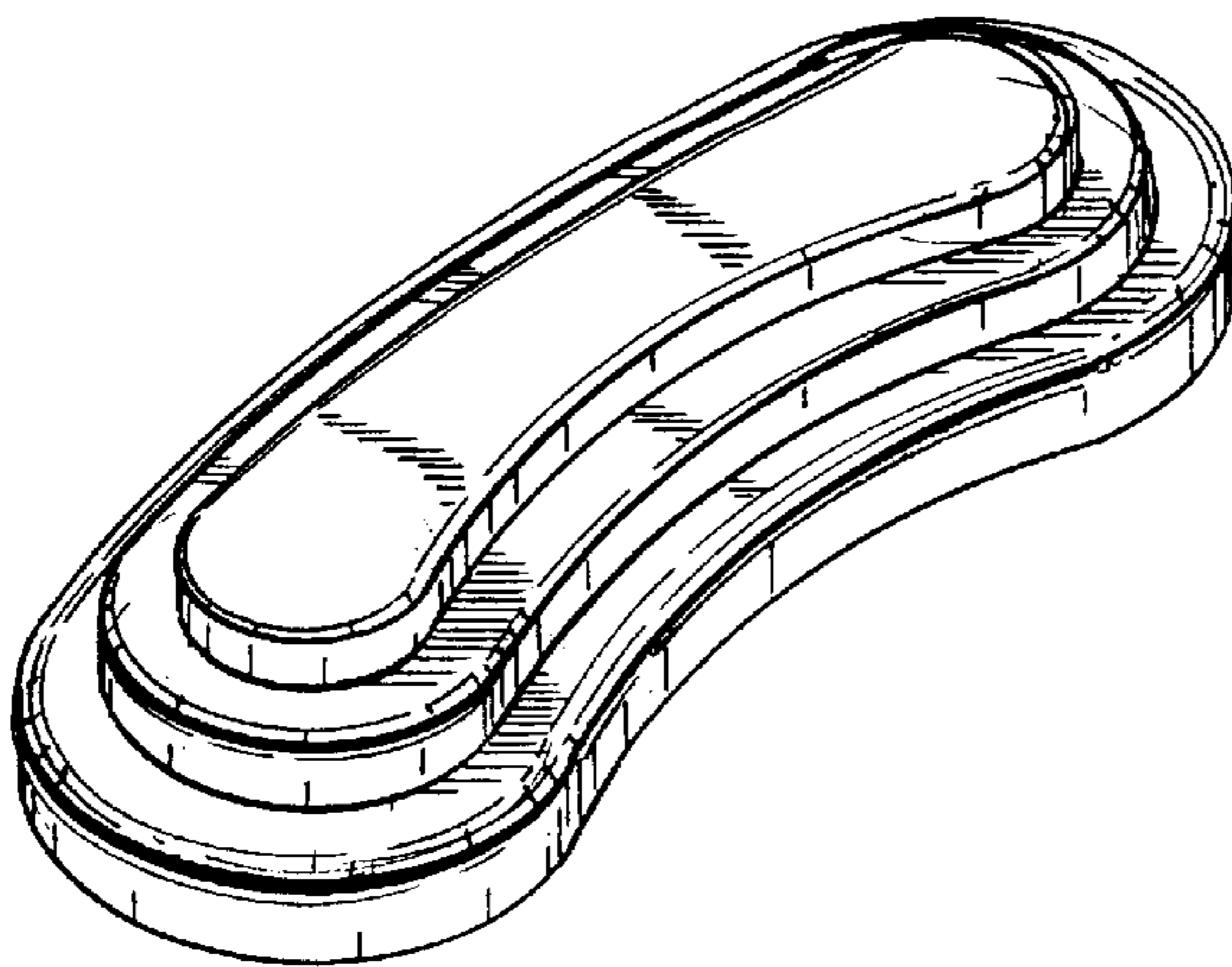

FIG. 1

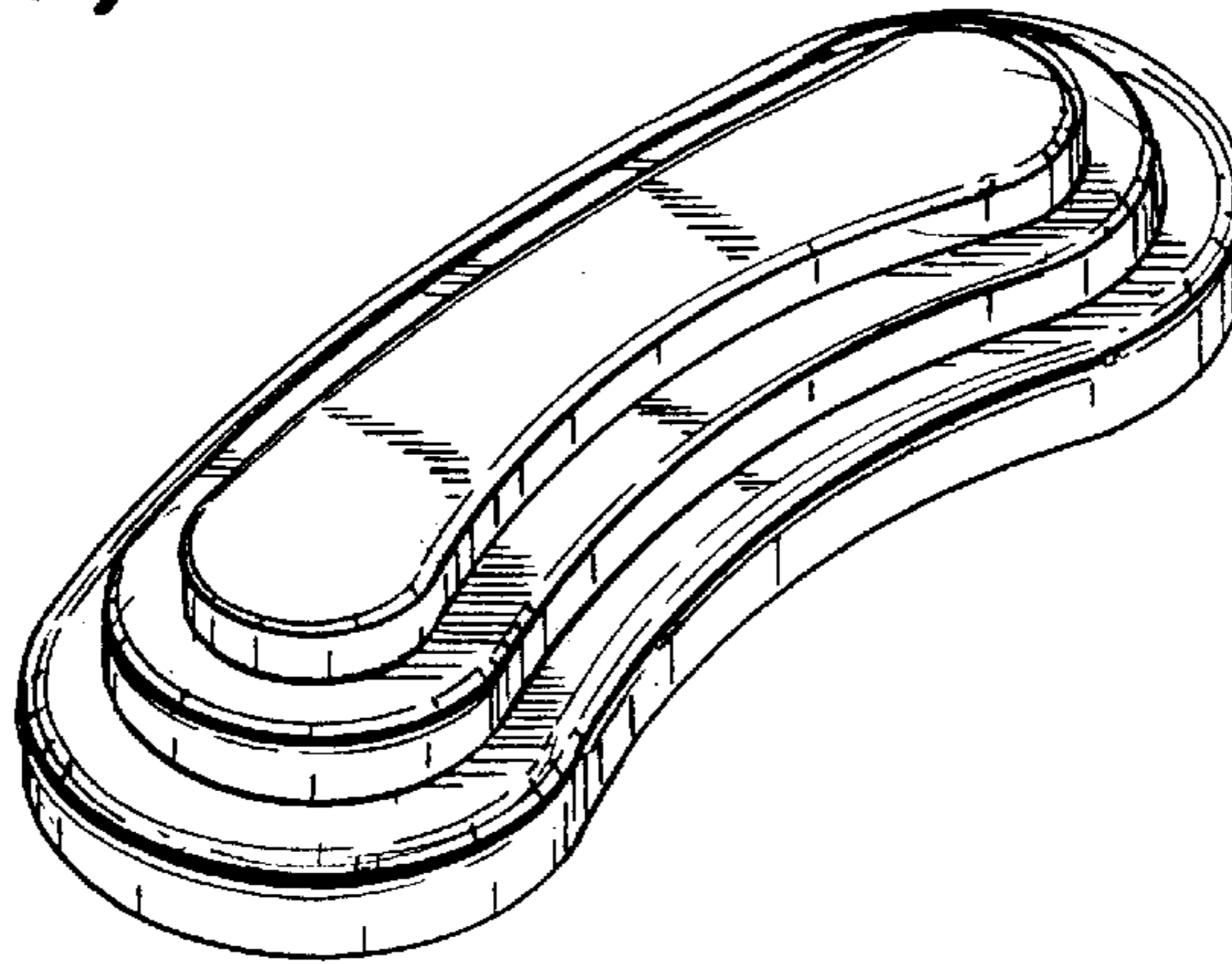

FIG. 2

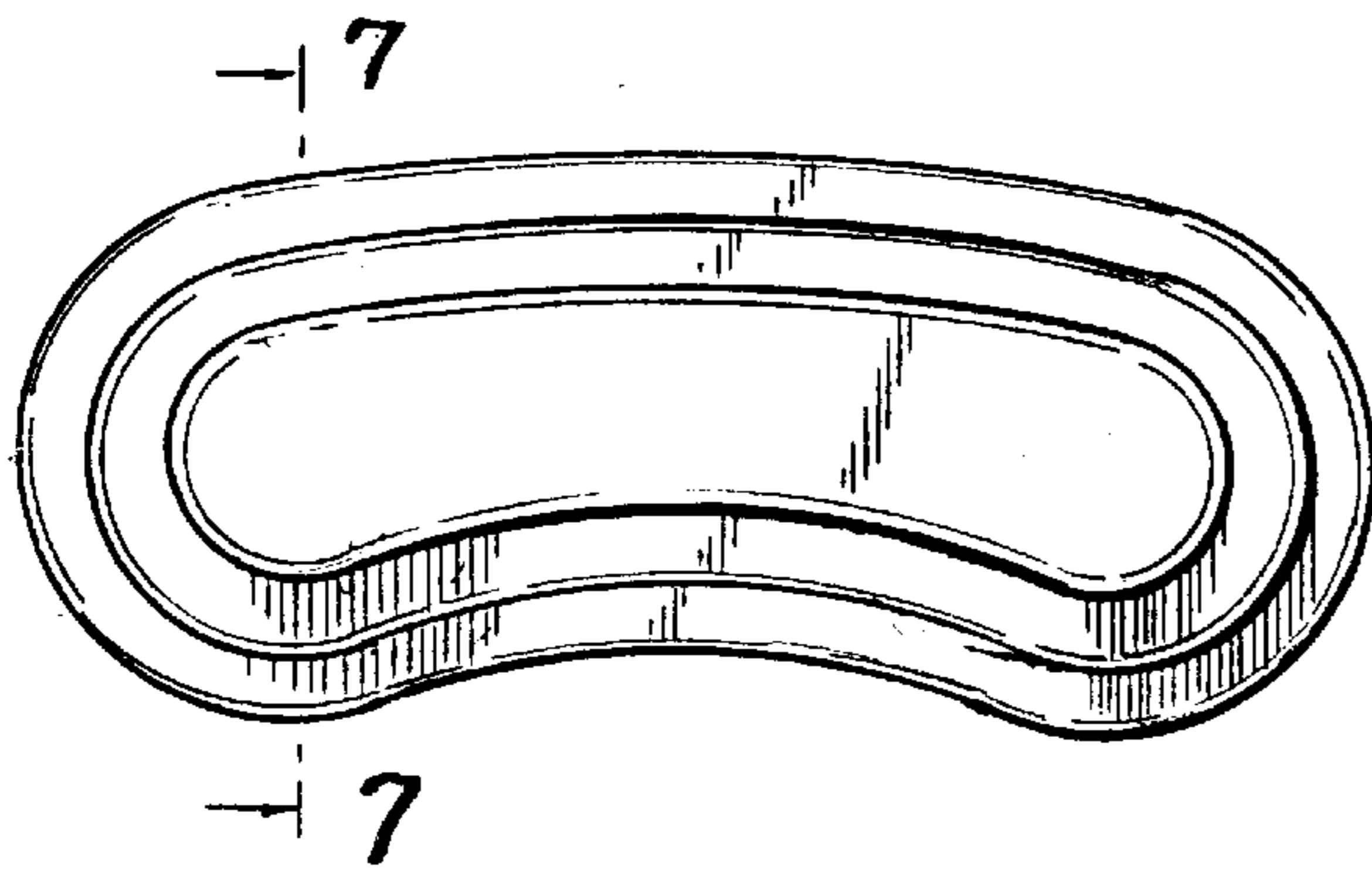

FIG. 3

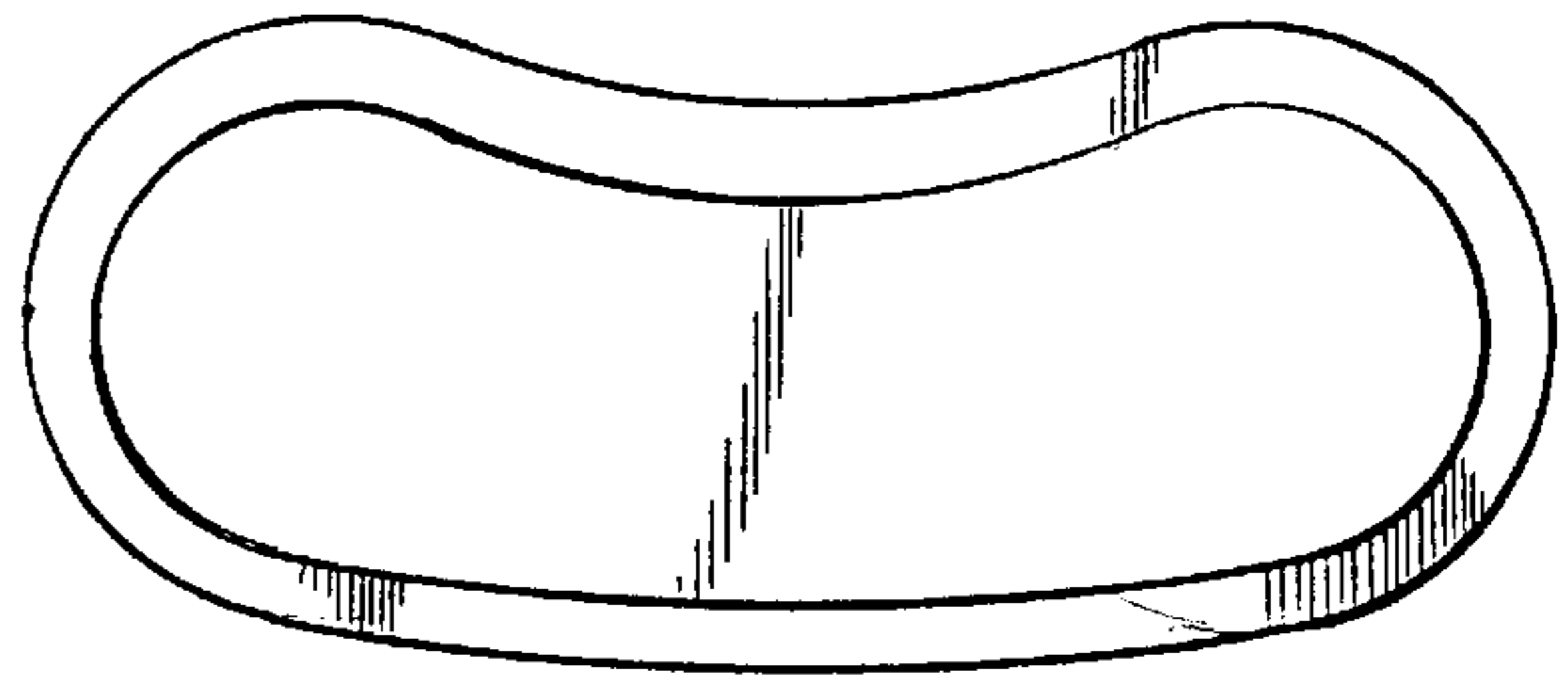

FIG. 4

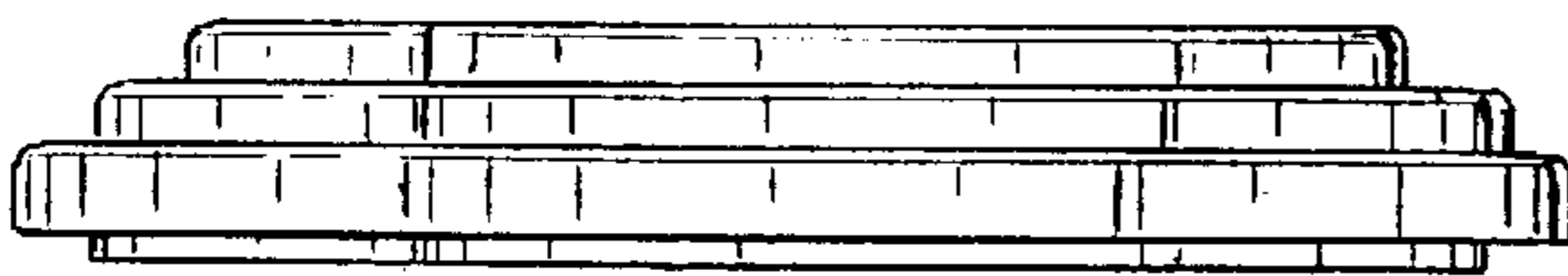

FIG. 5

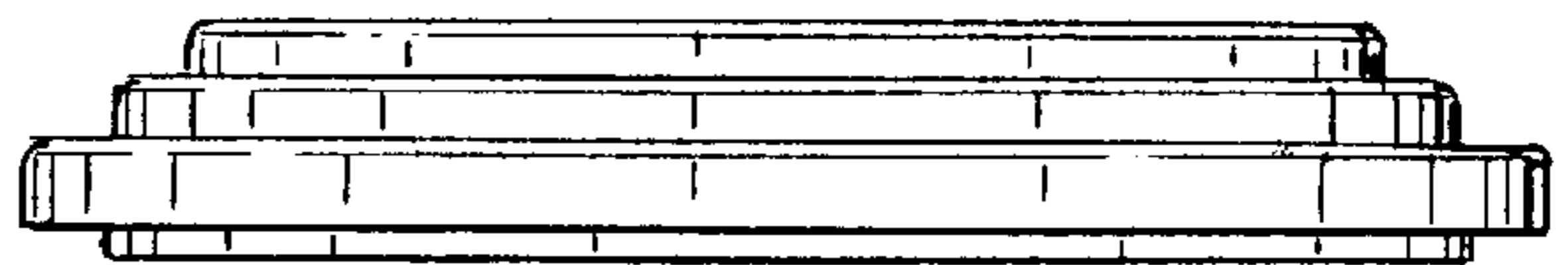

FIG. 6

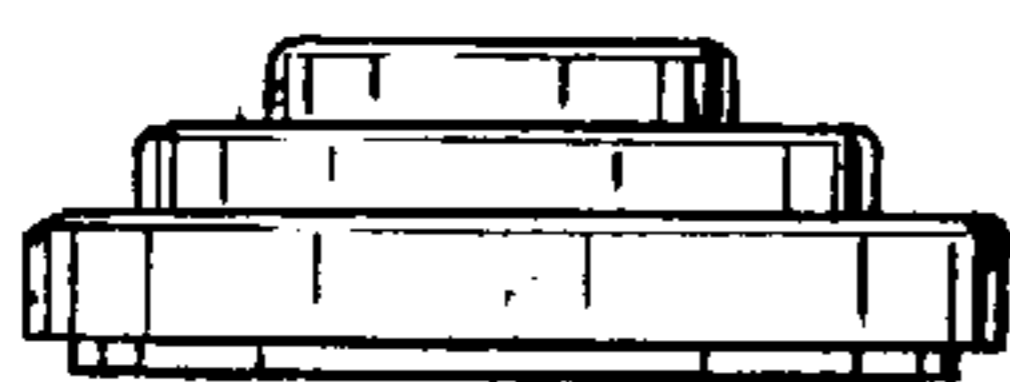

FIG. 7



FIG. 8

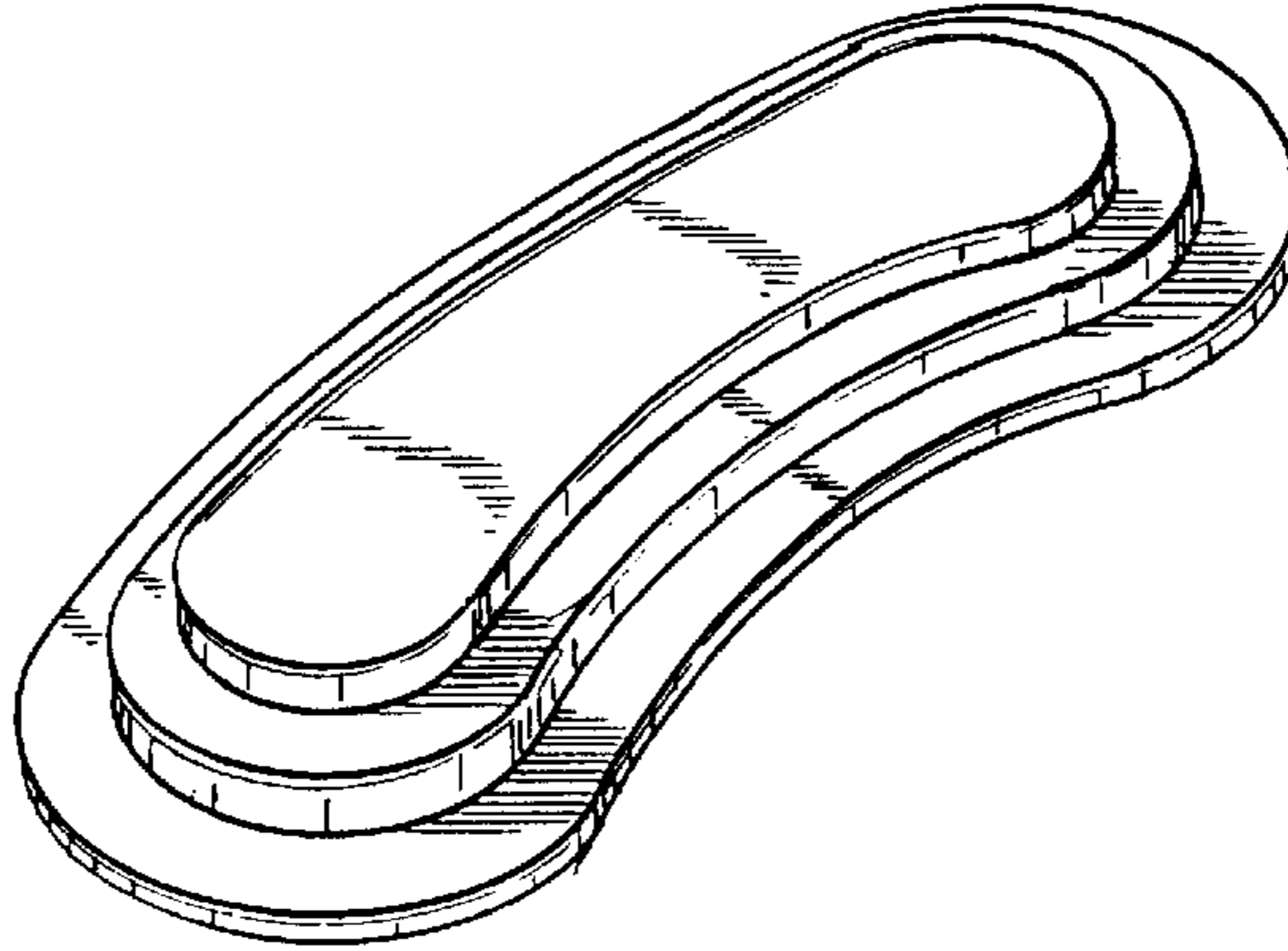

FIG. 9

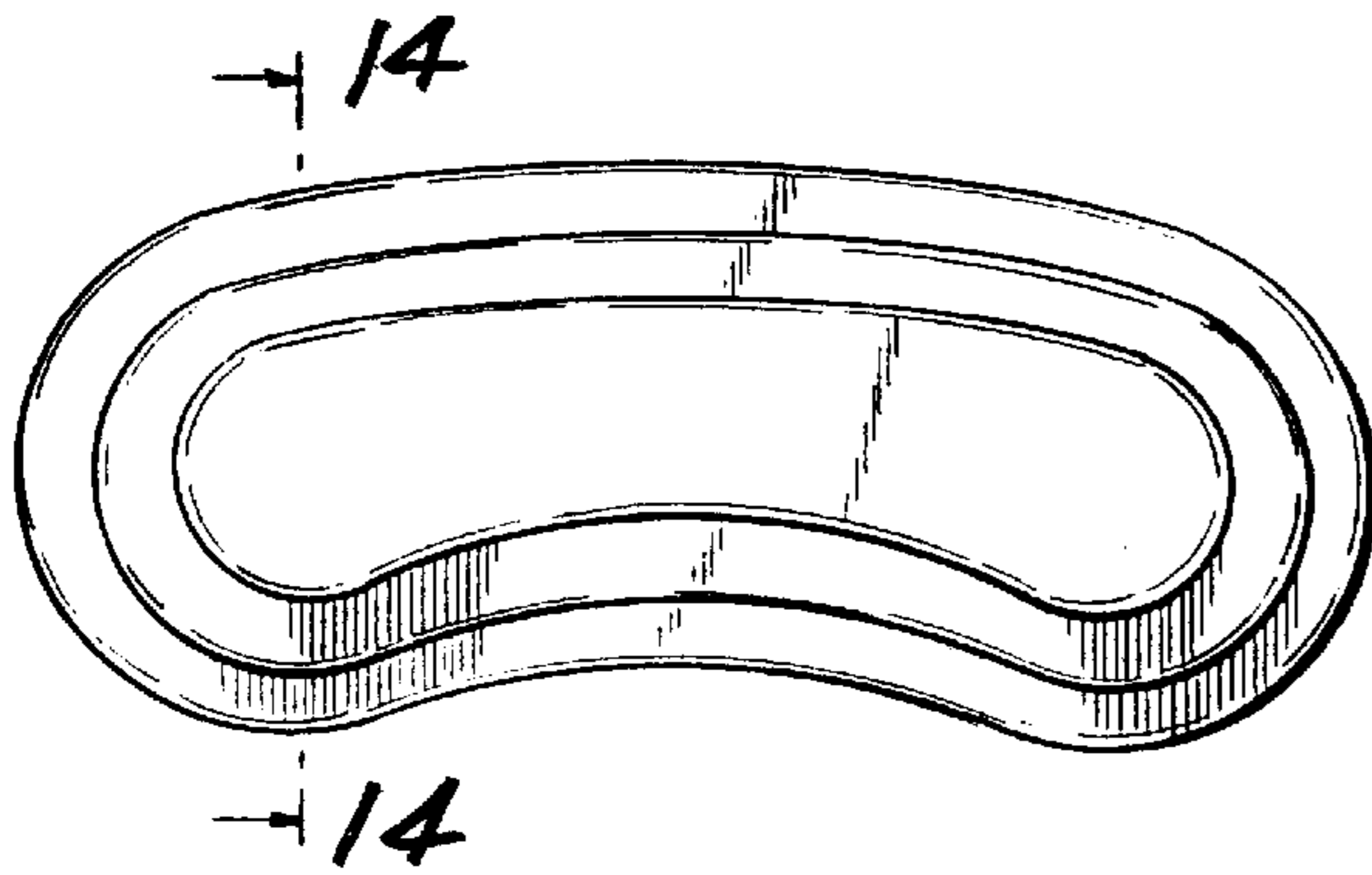

FIG. 10

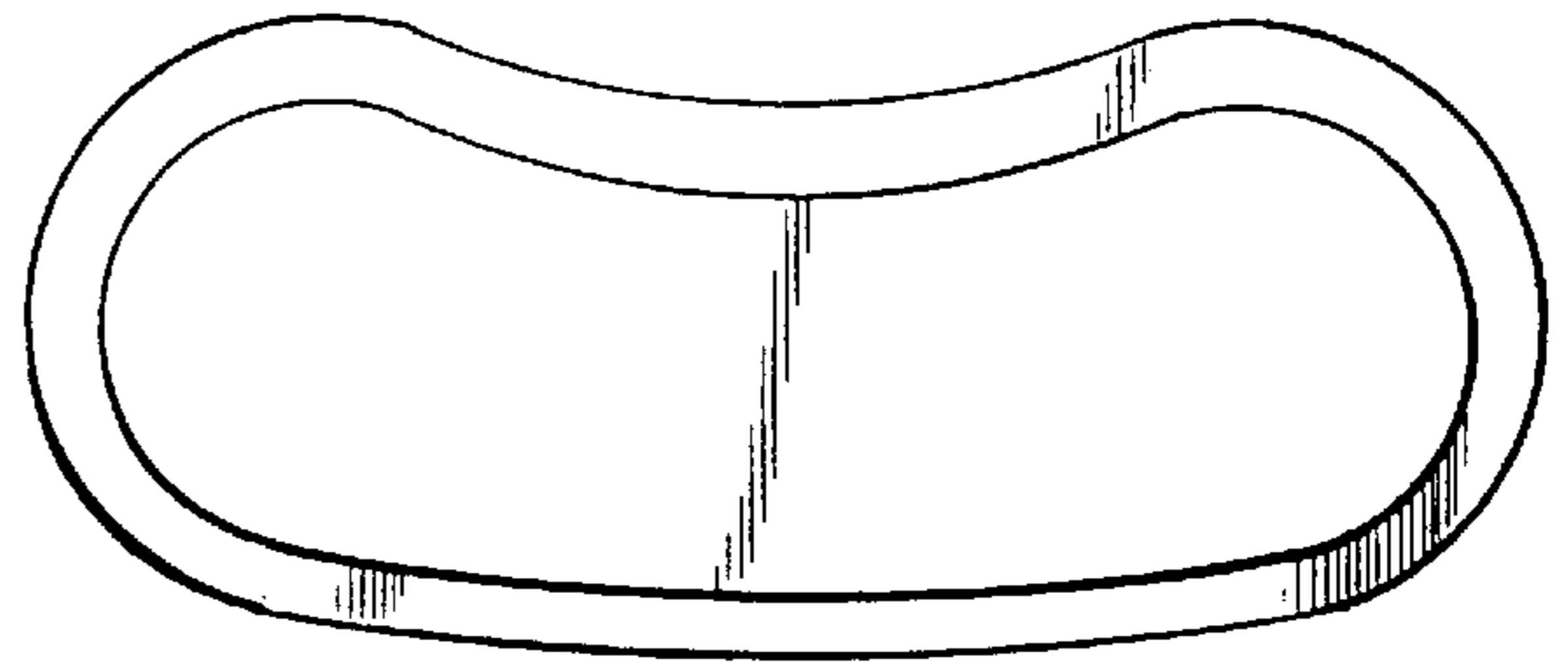

FIG. 11

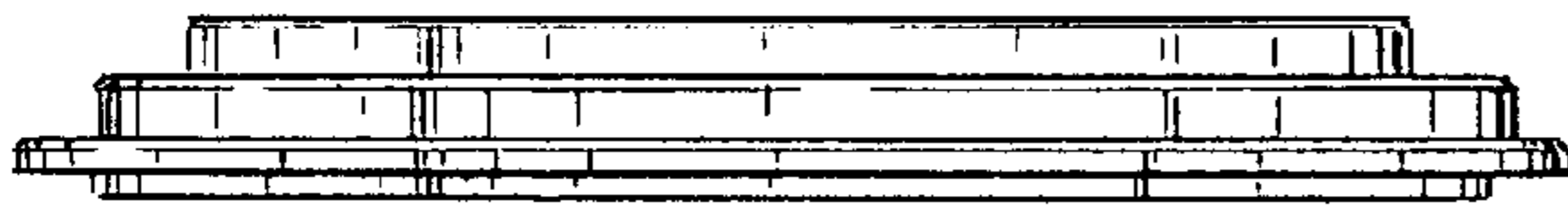

FIG. 12

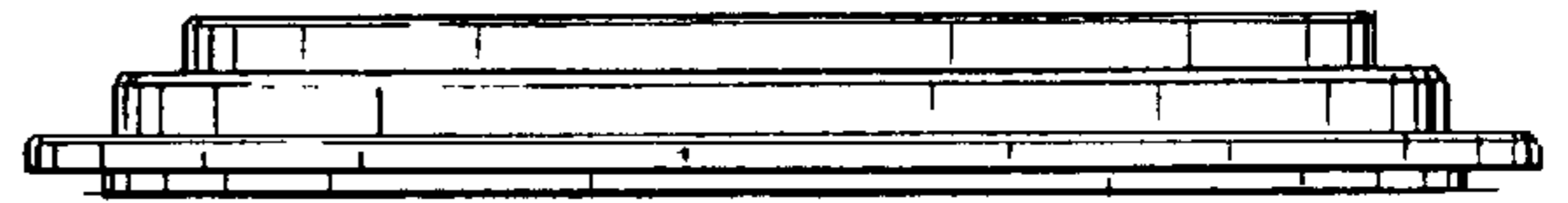

FIG. 13

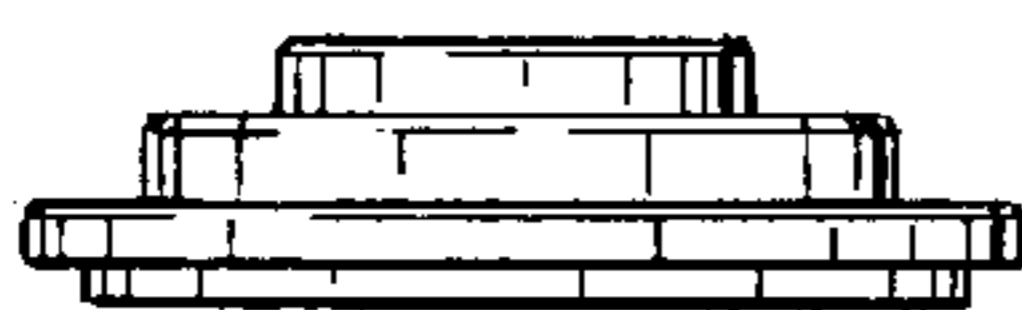

FIG. 14

