



US00D449916B1

(12) **United States Design Patent**
Salin et al.

(10) **Patent No.:** **US D449,916 S**

(45) **Date of Patent:** **** Oct. 30, 2001**

(54) **FORK LIFT TRUCK**

(75) Inventors: **Sergio Salin; Nicola Piccardo**, both of Milan (IT)

(73) Assignee: **Fiat Om Carelli Elevatori S.p.A.** (IT)

(**) Term: **14 Years**

(21) Appl. No.: **29/129,022**

(22) Filed: **Sep. 5, 2000**

(30) **Foreign Application Priority Data**

Mar. 6, 2000 (DE) 400 02 577

(51) **LOC (7) Cl.** **12-05**

(52) **U.S. Cl.** **D34/34**

(58) **Field of Search** D34/28, 34; 180/89.12, 180/89.17, 89.14; 280/402; 414/579, 785, 607; D12/14, 15

(56) **References Cited**

U.S. PATENT DOCUMENTS

- D. 353,704 * 12/1994 Bhambra D34/37
- D. 354,604 * 1/1995 Soederberg D34/34
- D. 376,242 * 12/1996 Jung et al. D34/34
- D. 376,243 * 12/1996 Magni D34/34
- D. 427,409 * 6/2000 Sato et al. D34/34
- D. 432,753 * 10/2000 Braud D34/34

* cited by examiner

Primary Examiner—Cynthia E. Ramirez

(74) *Attorney, Agent, or Firm*—Webb Ziesenheim Logsdon Orkin & Hanson, P.C.

(57) **CLAIM**

The ornamental design for a fork lift truck, as shown and described.

DESCRIPTION

FIG. 1 is a perspective view of a fork lift truck taken from the left front showing my new design with the fork extended in a first position;

FIG. 2 is a perspective view thereof taken from the right rear;

FIG. 3 is a front elevation view thereof;

FIG. 4 is a rear elevation view thereof;

FIG. 5 is a left side elevation view thereof;

FIG. 6 is a right side elevation view thereof;

FIG. 7 is a top plan view thereof;

FIG. 8 is a bottom plan view thereof;

FIG. 9 is a perspective view thereof taken from the left front with the fork retracted in a second position;

FIG. 10 is a perspective view thereof taken from the left rear;

FIG. 11 is a front elevation view thereof;

FIG. 12 is a rear elevation view thereof;

FIG. 13 is a left side elevation view thereof;

FIG. 14 is a right side elevation view thereof;

FIG. 15 is a top plan view thereof; and,

FIG. 16 is a bottom plan view thereof.

1 Claim, 16 Drawing Sheets

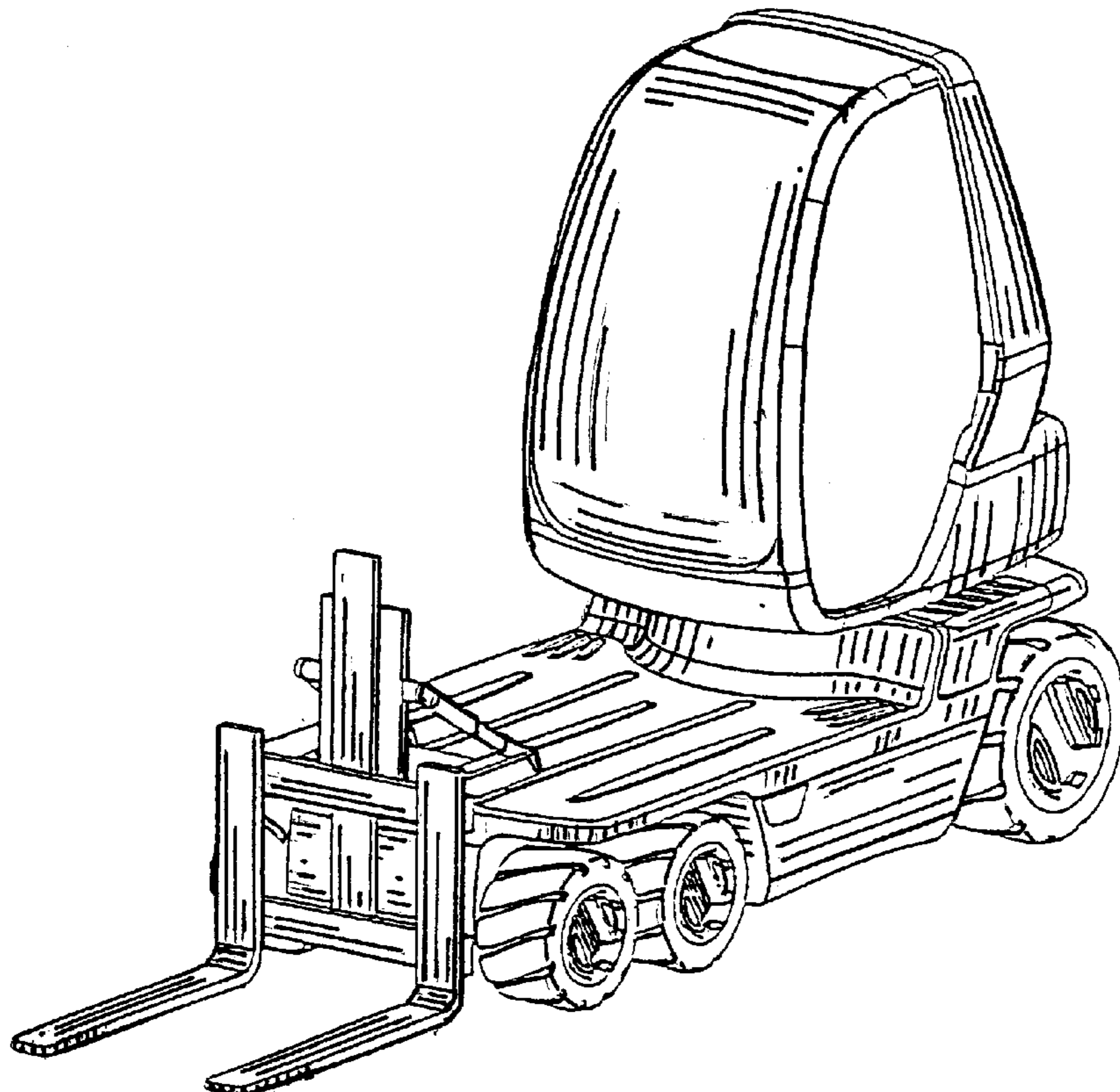

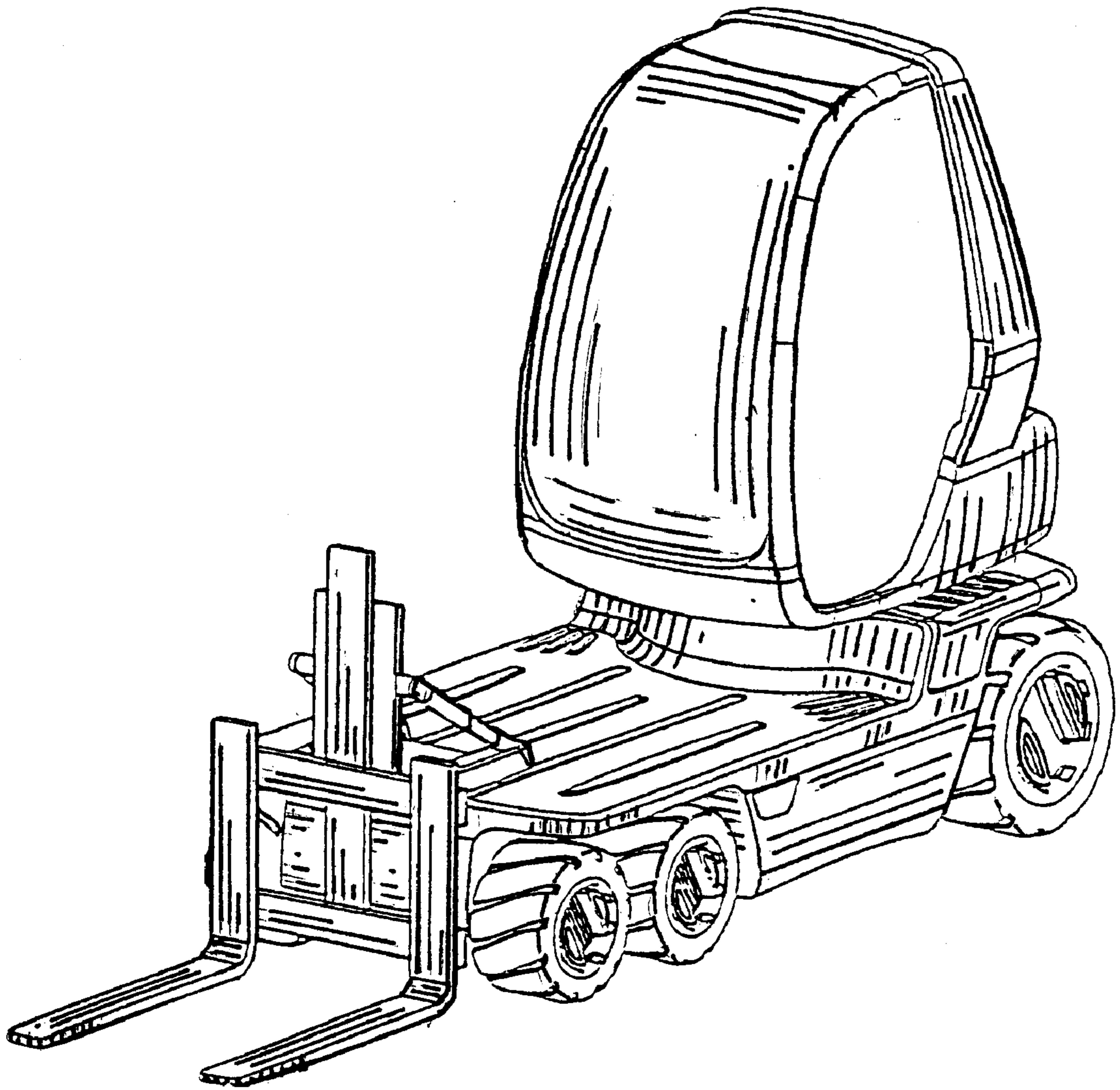

Fig. 1

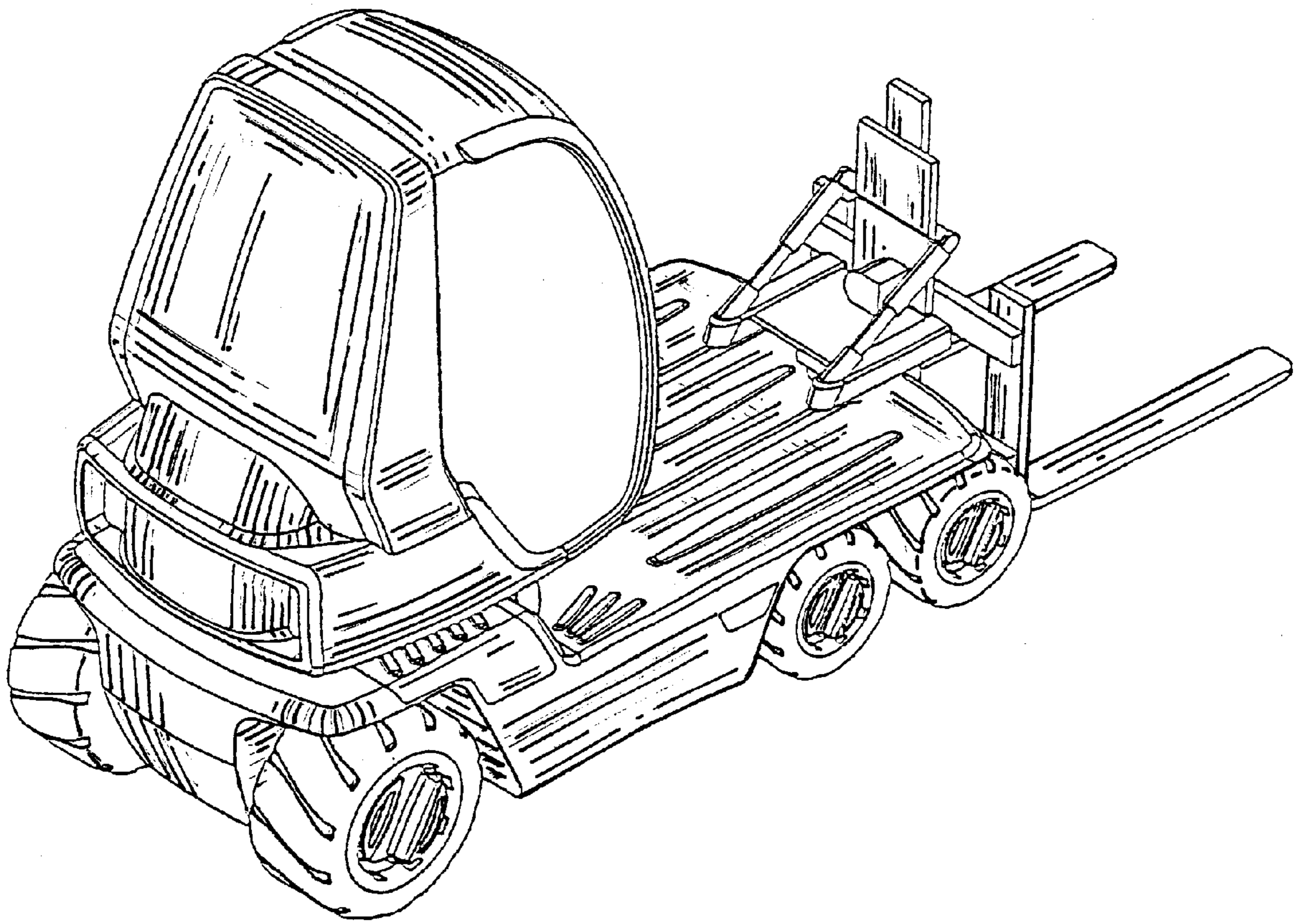

Fig. 2

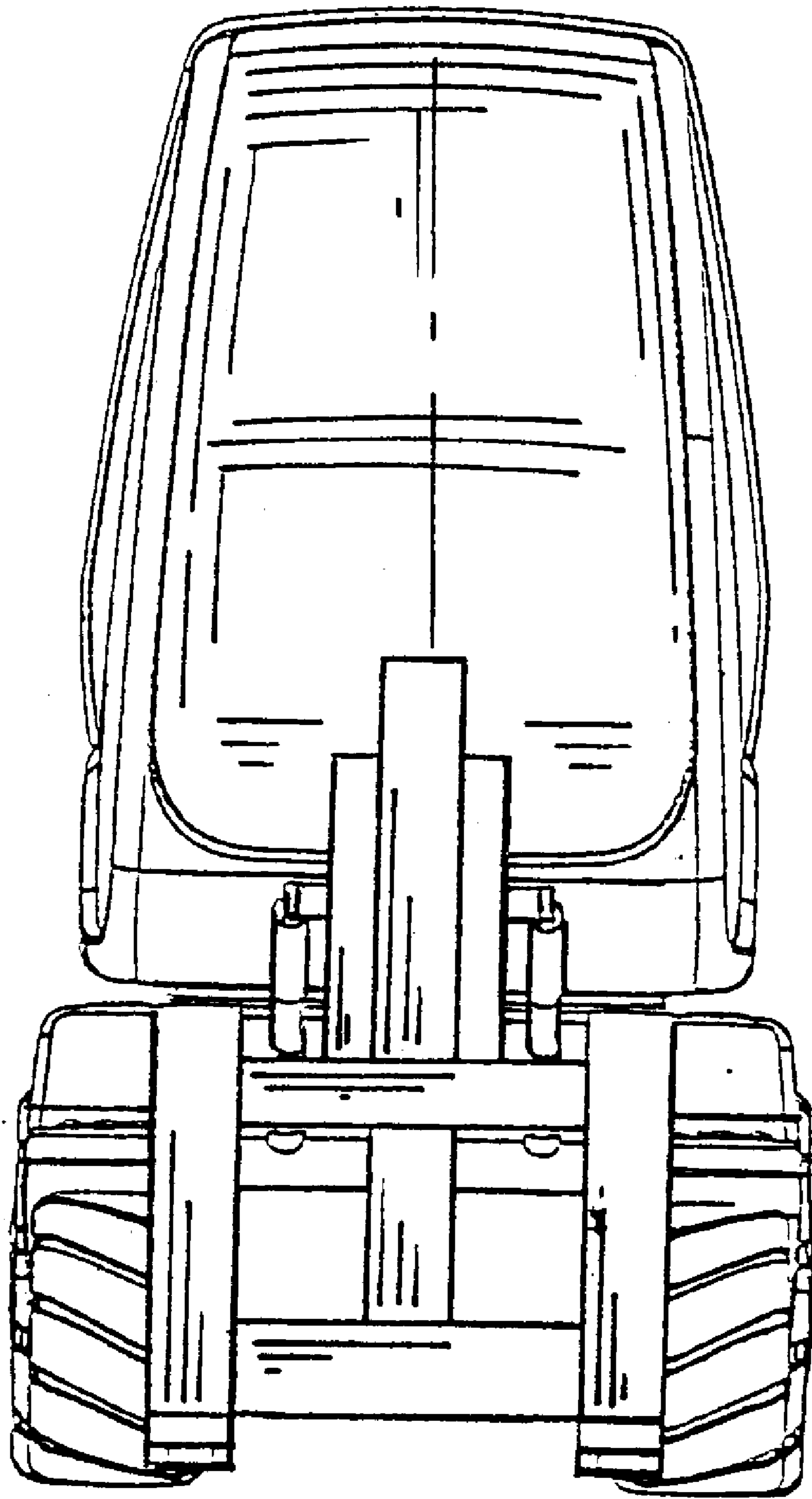

Fig. 3

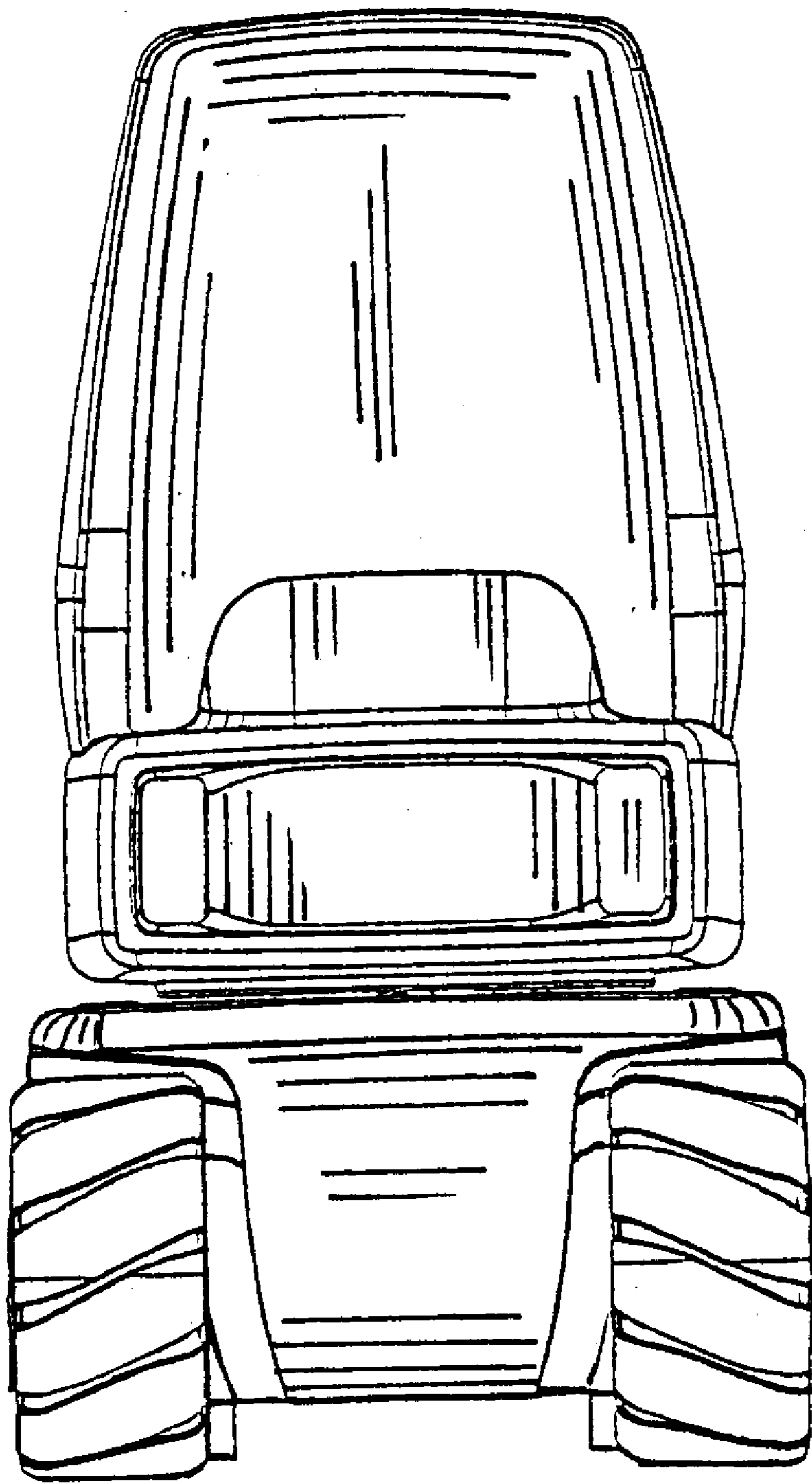

Fig. 4

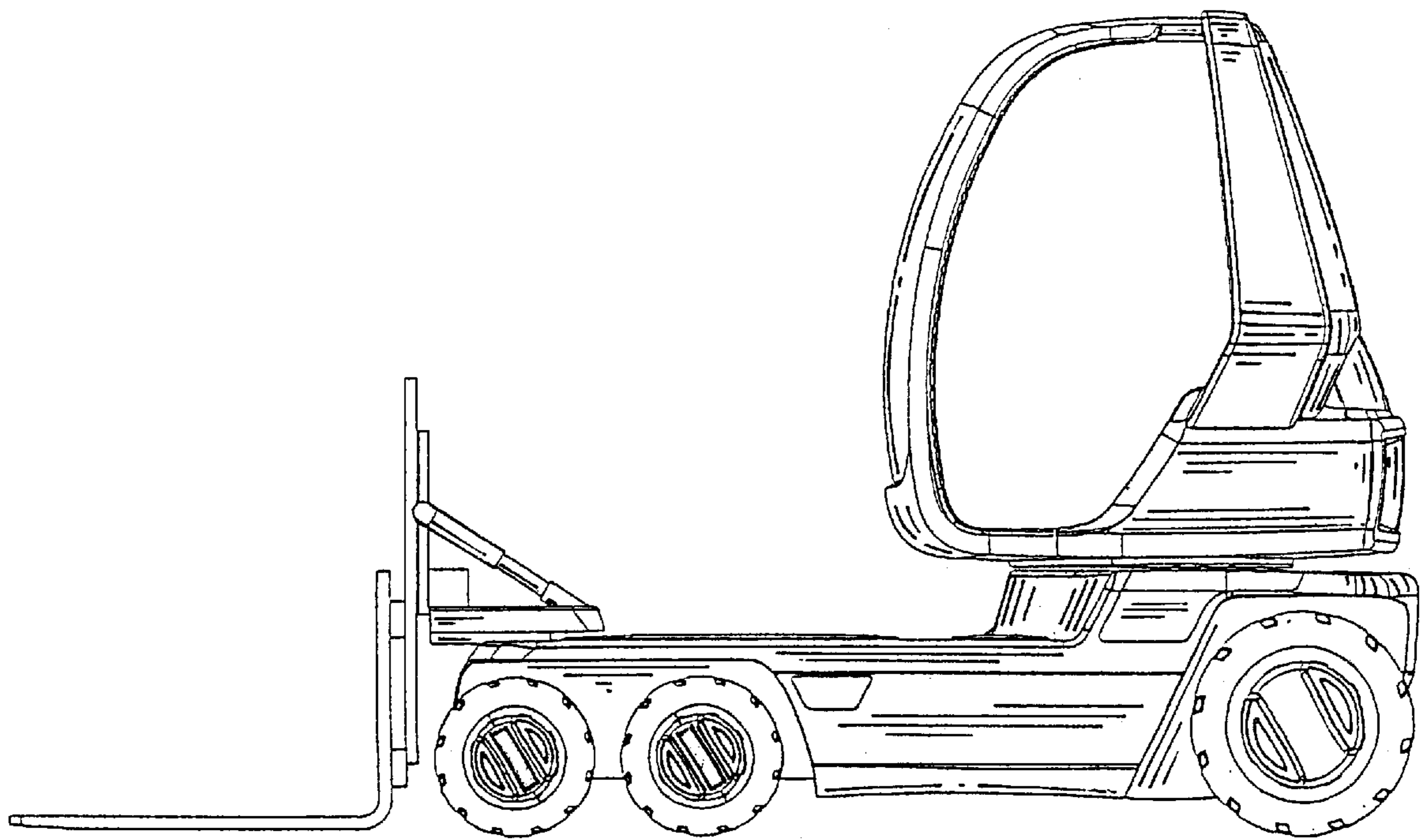

Fig. 5

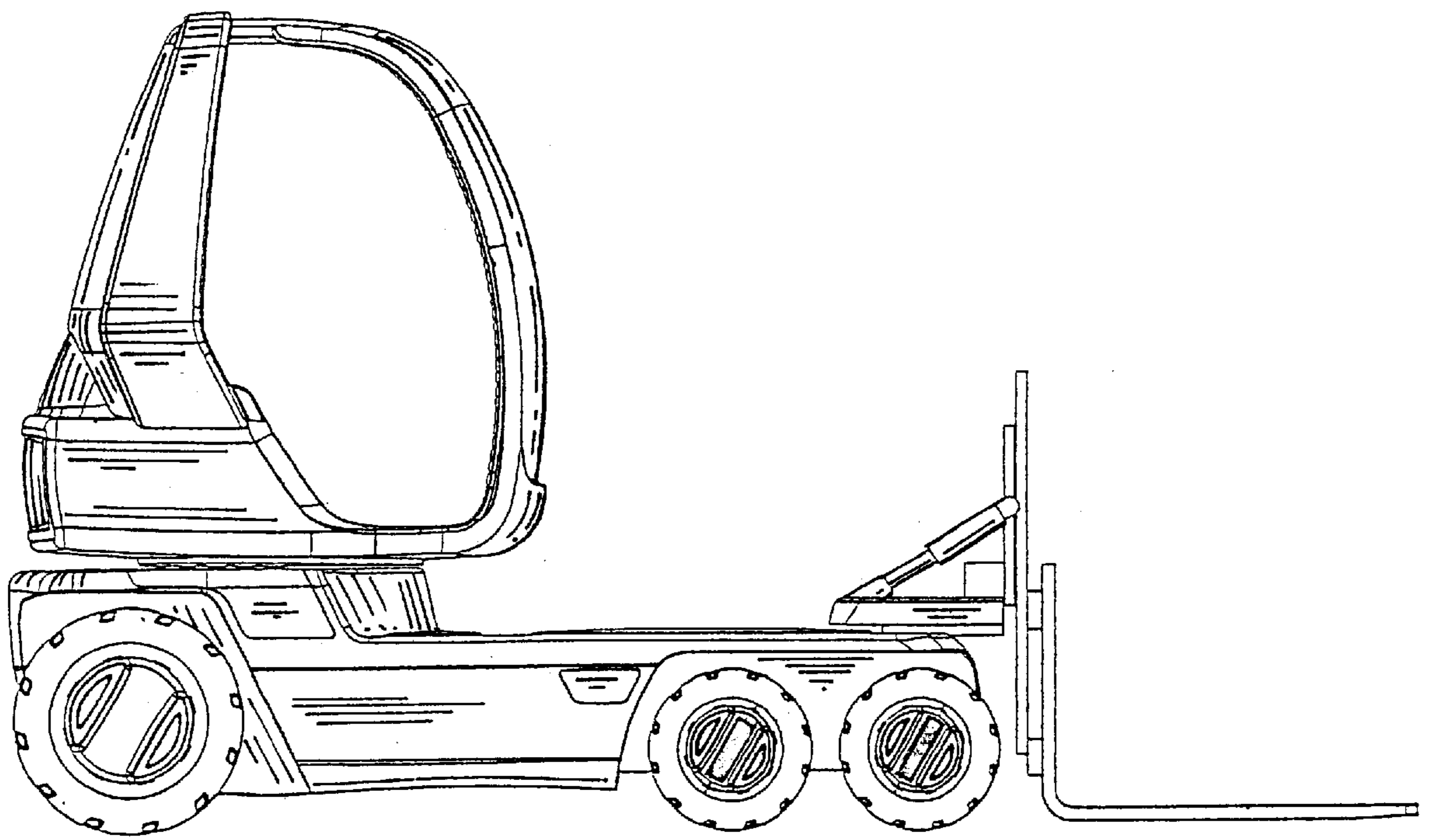

Fig. 6

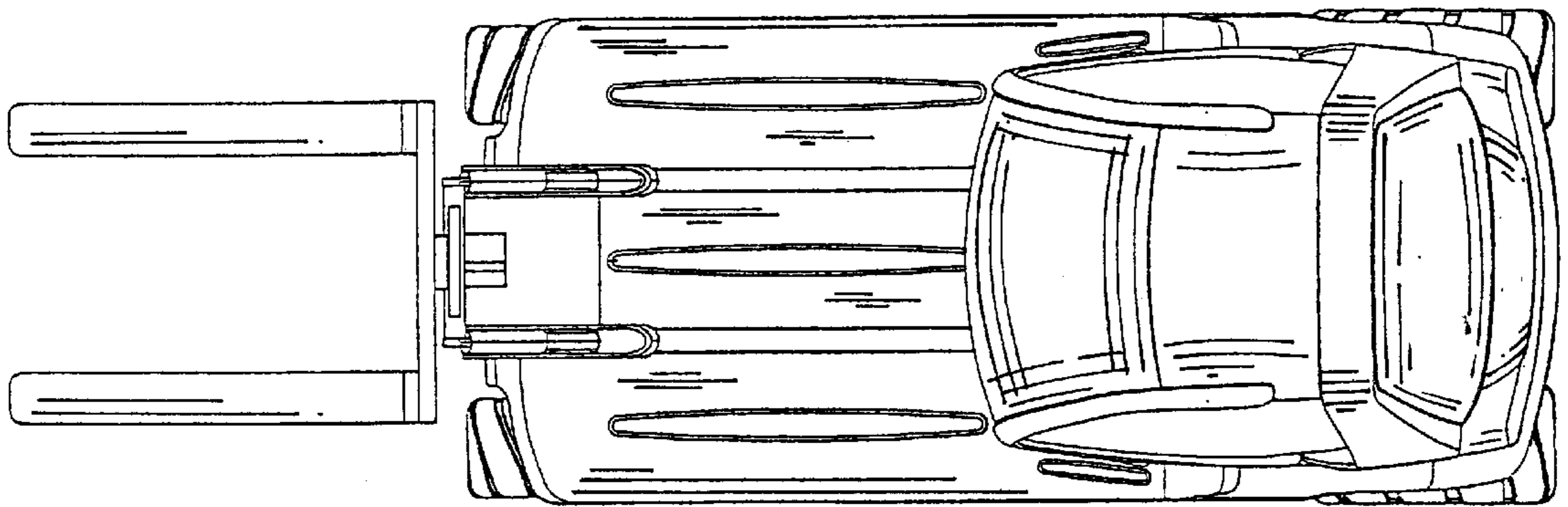

Fig. 7

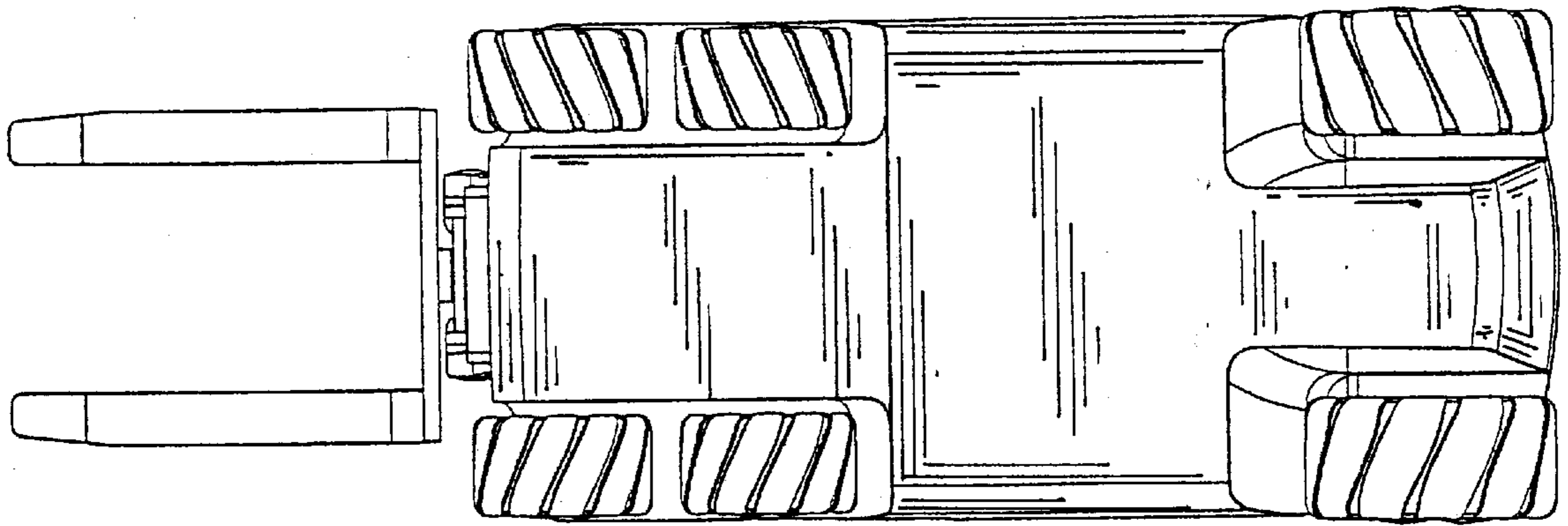

Fig. 8

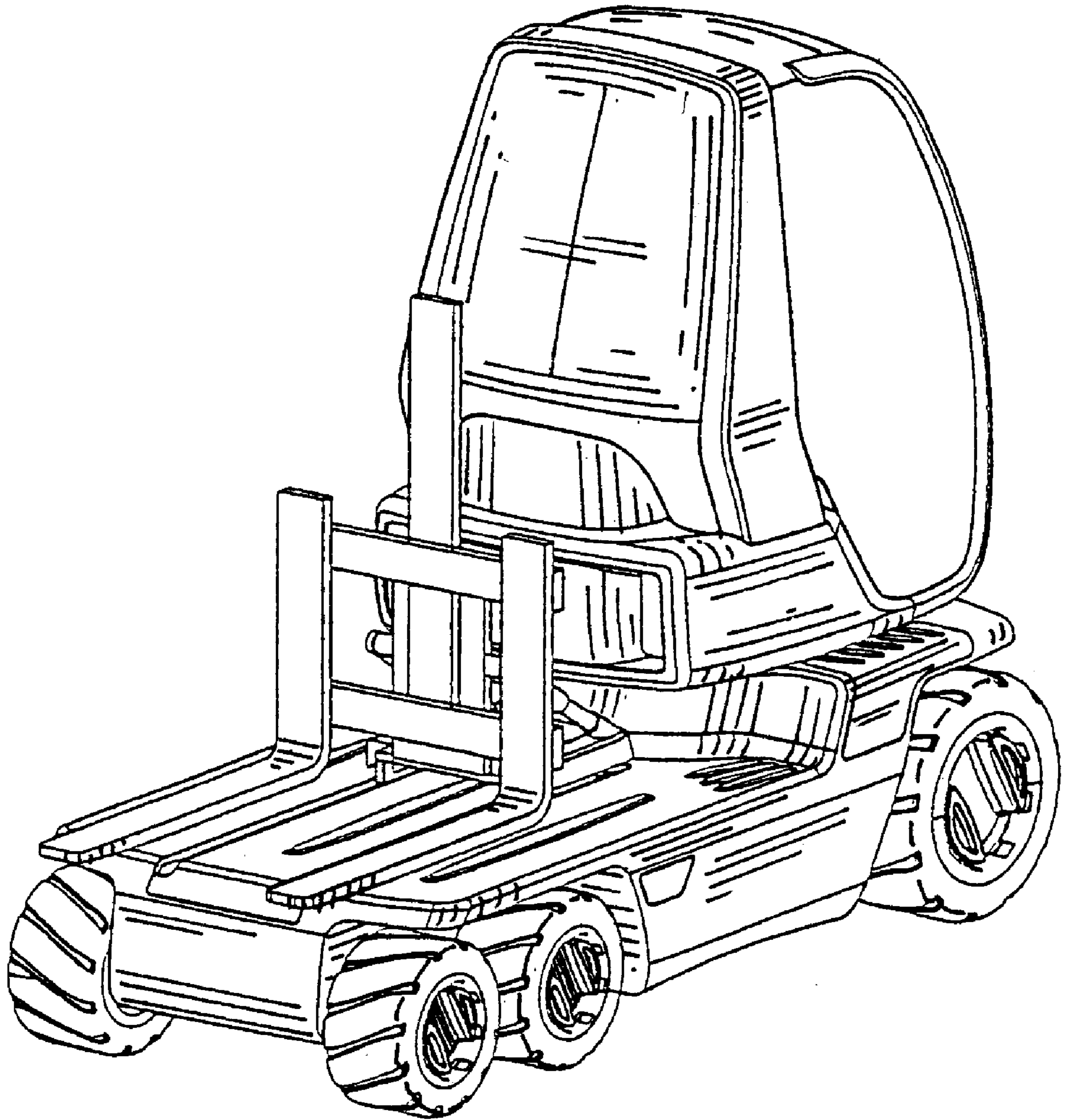

Fig. 9

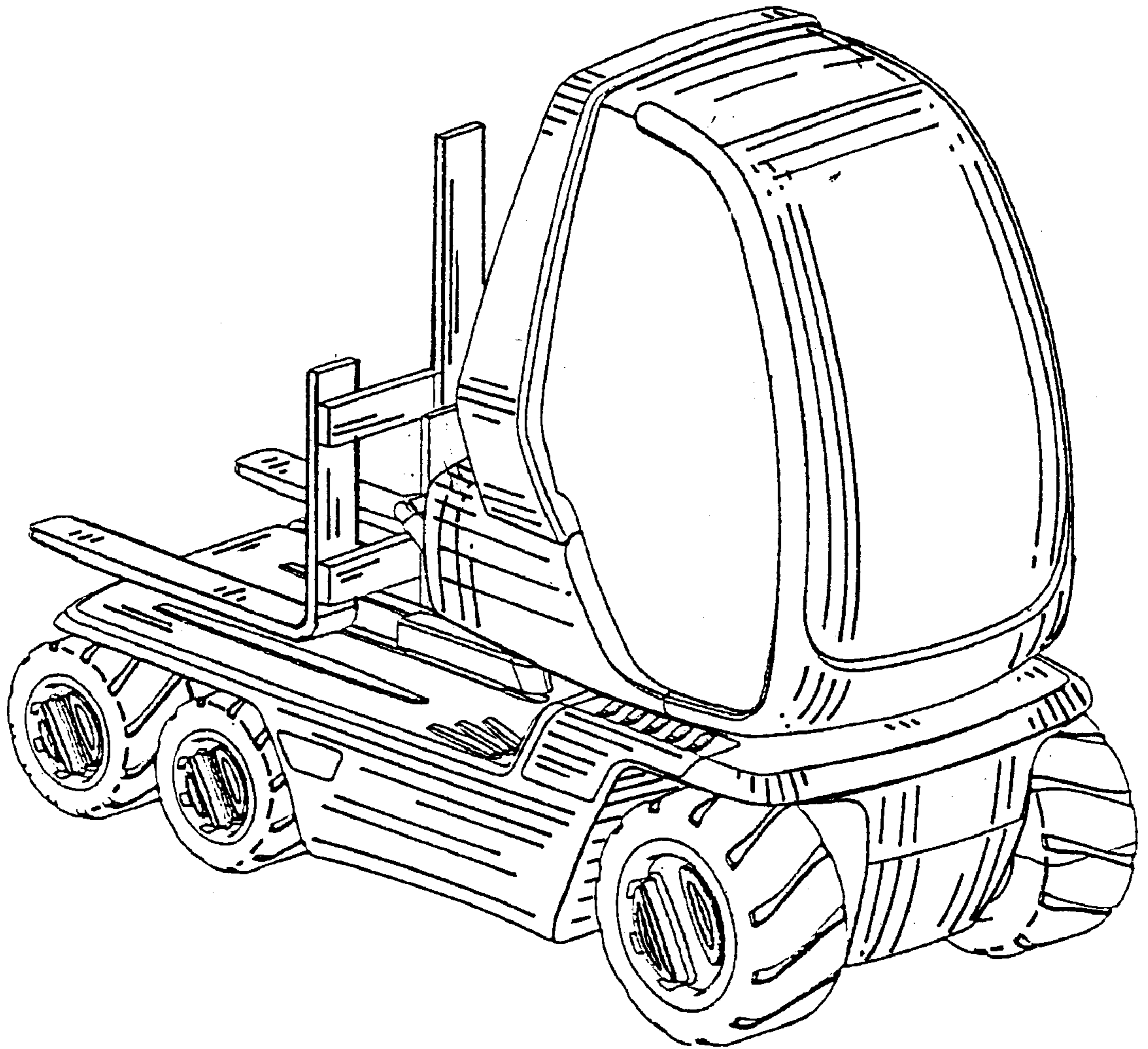

Fig. 10

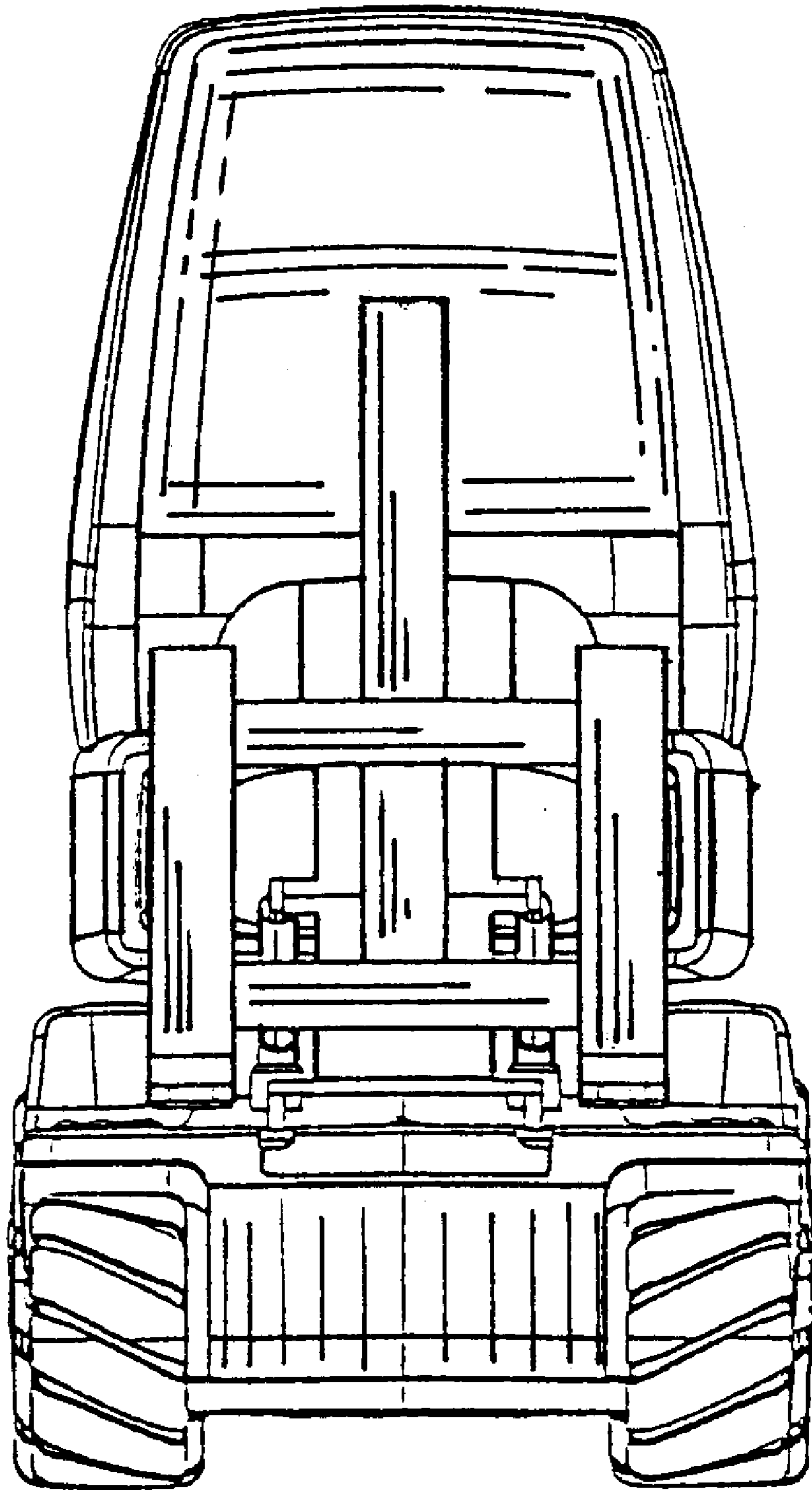

Fig. 11

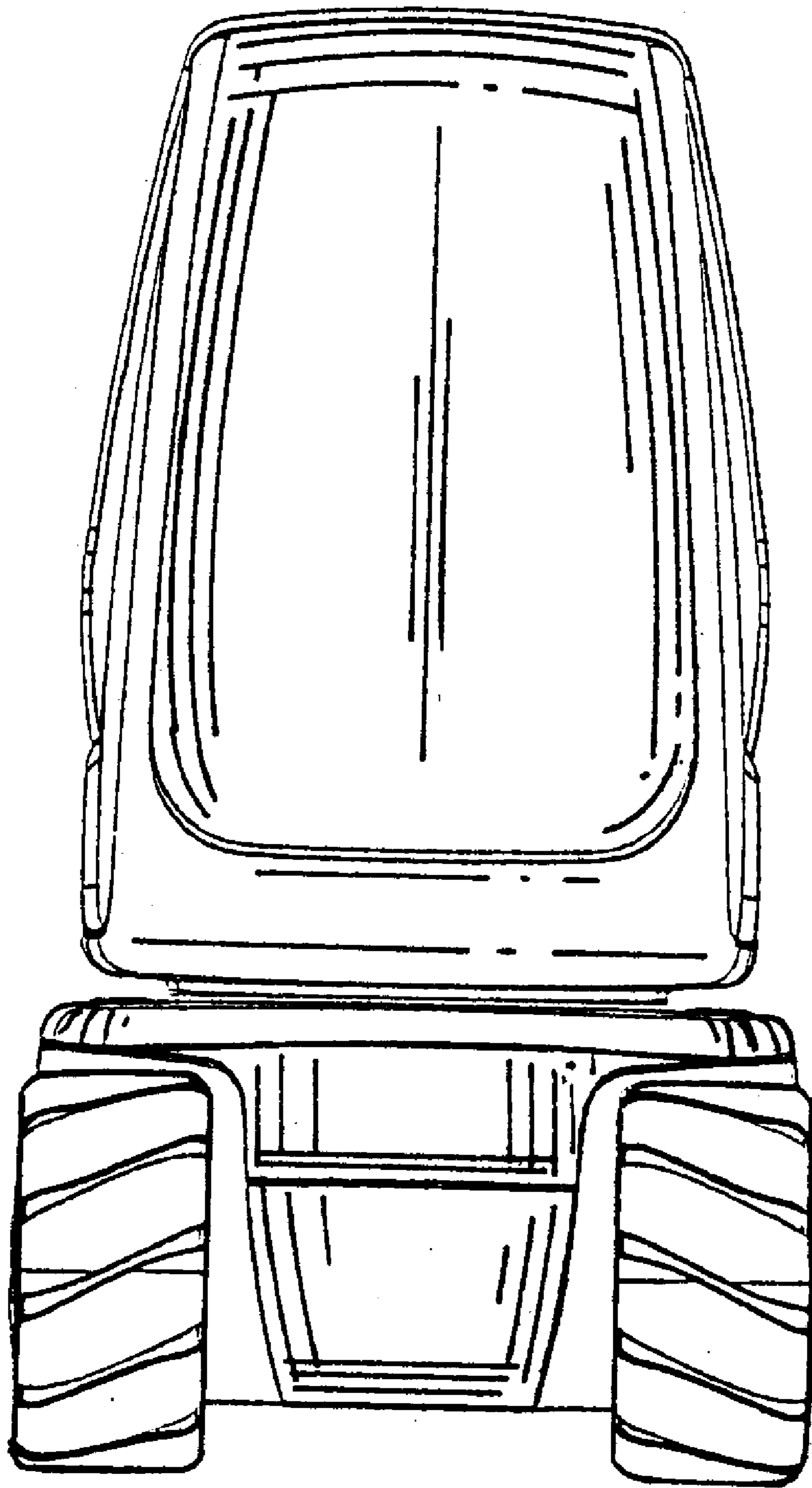

Fig. 12

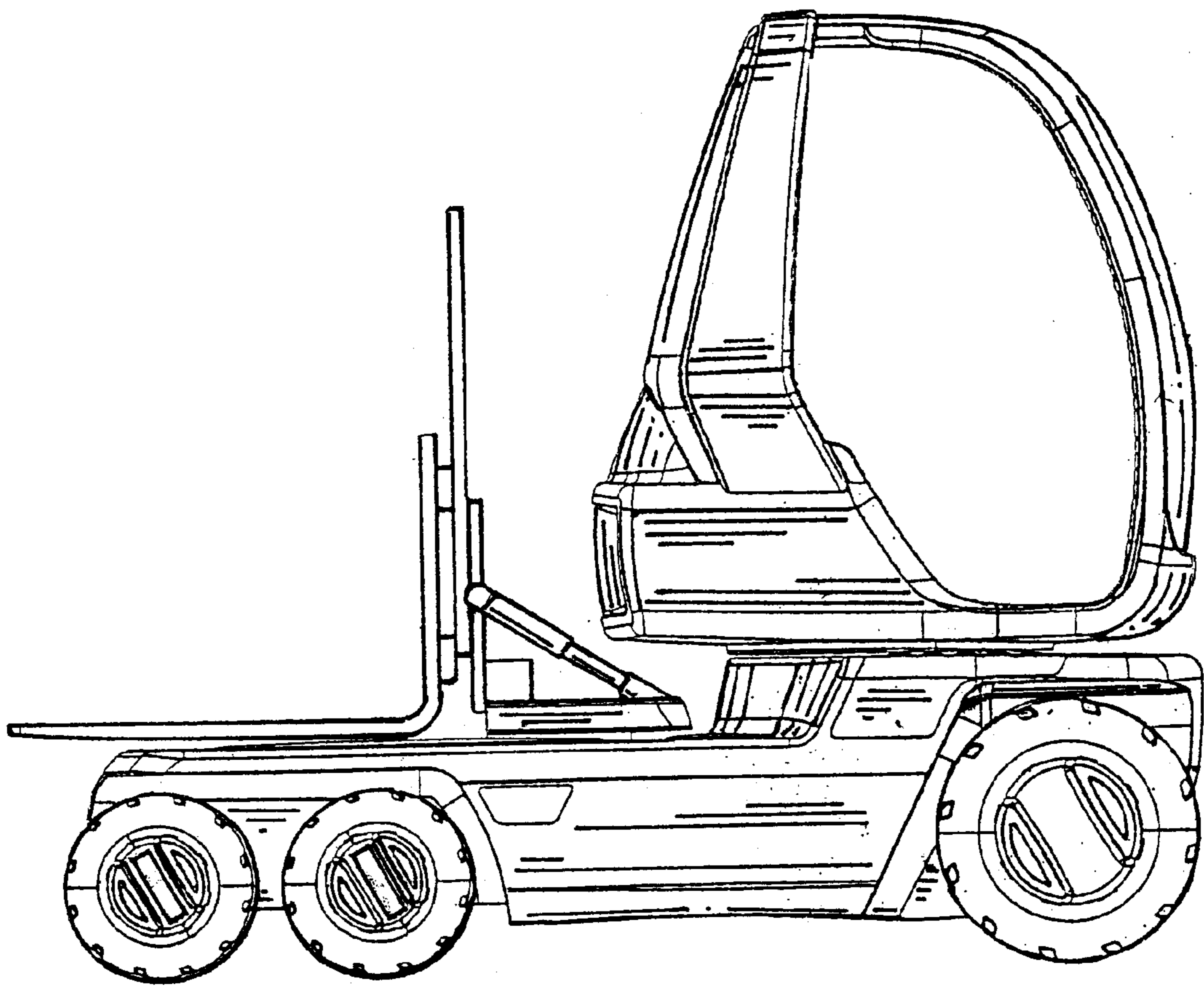

Fig. 13

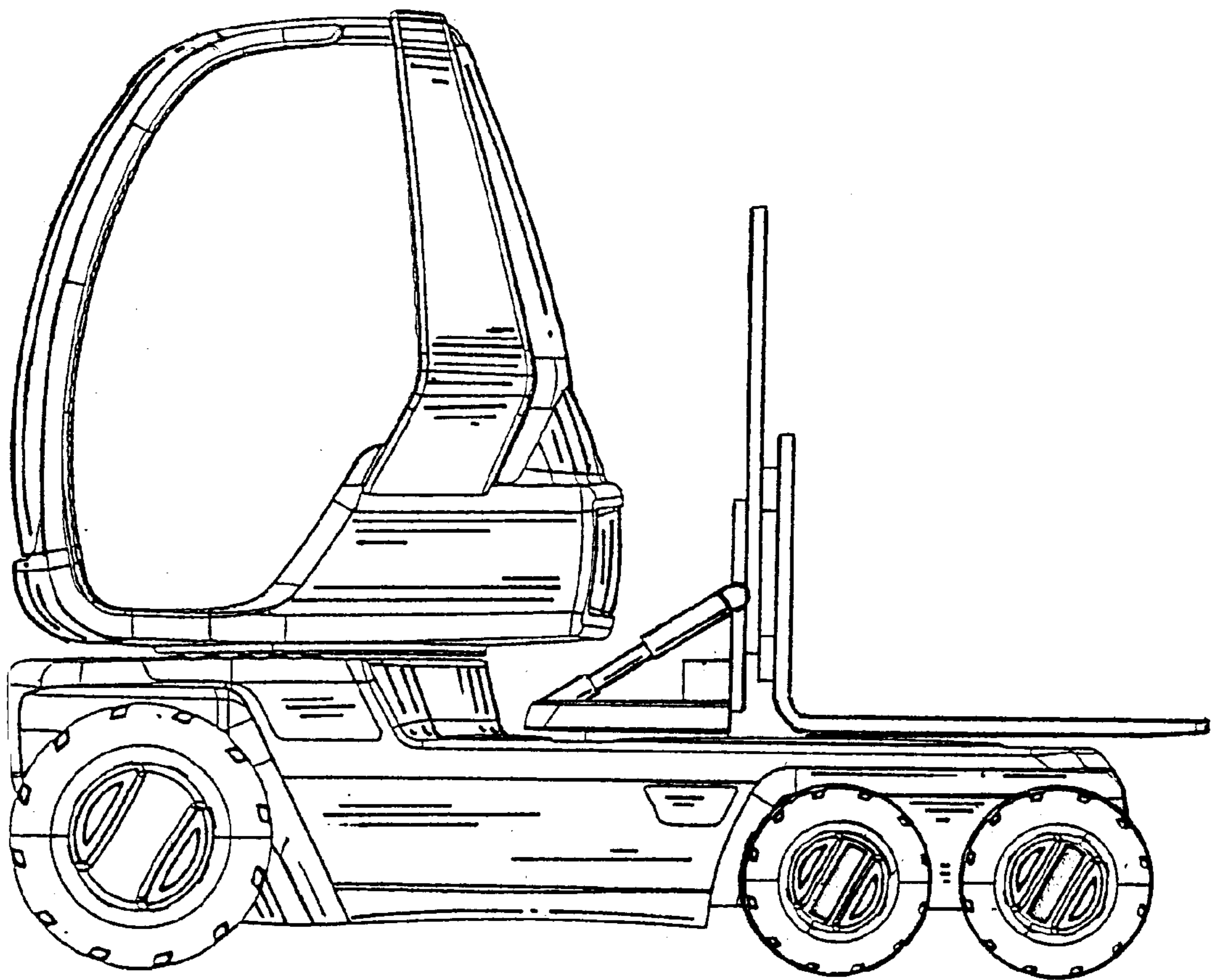

Fig. 14

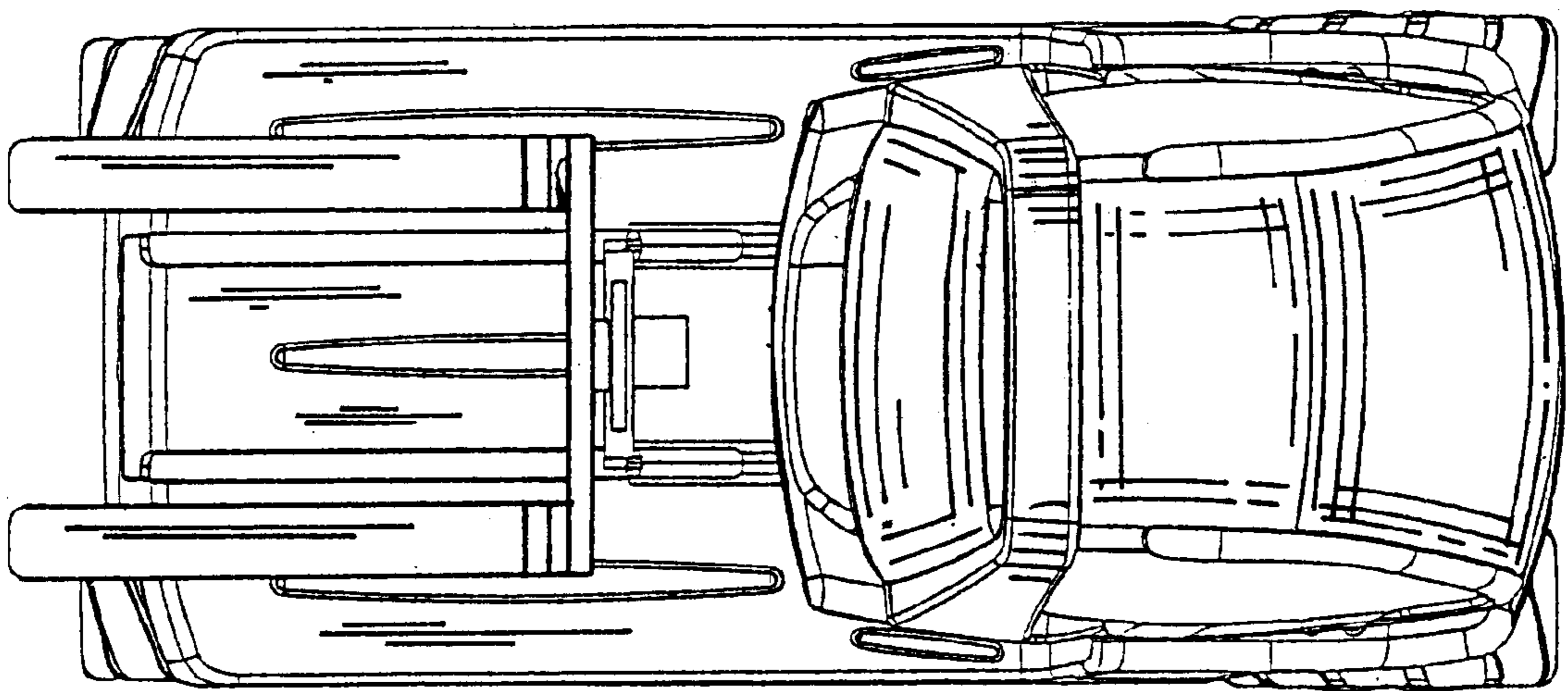

Fig. 15

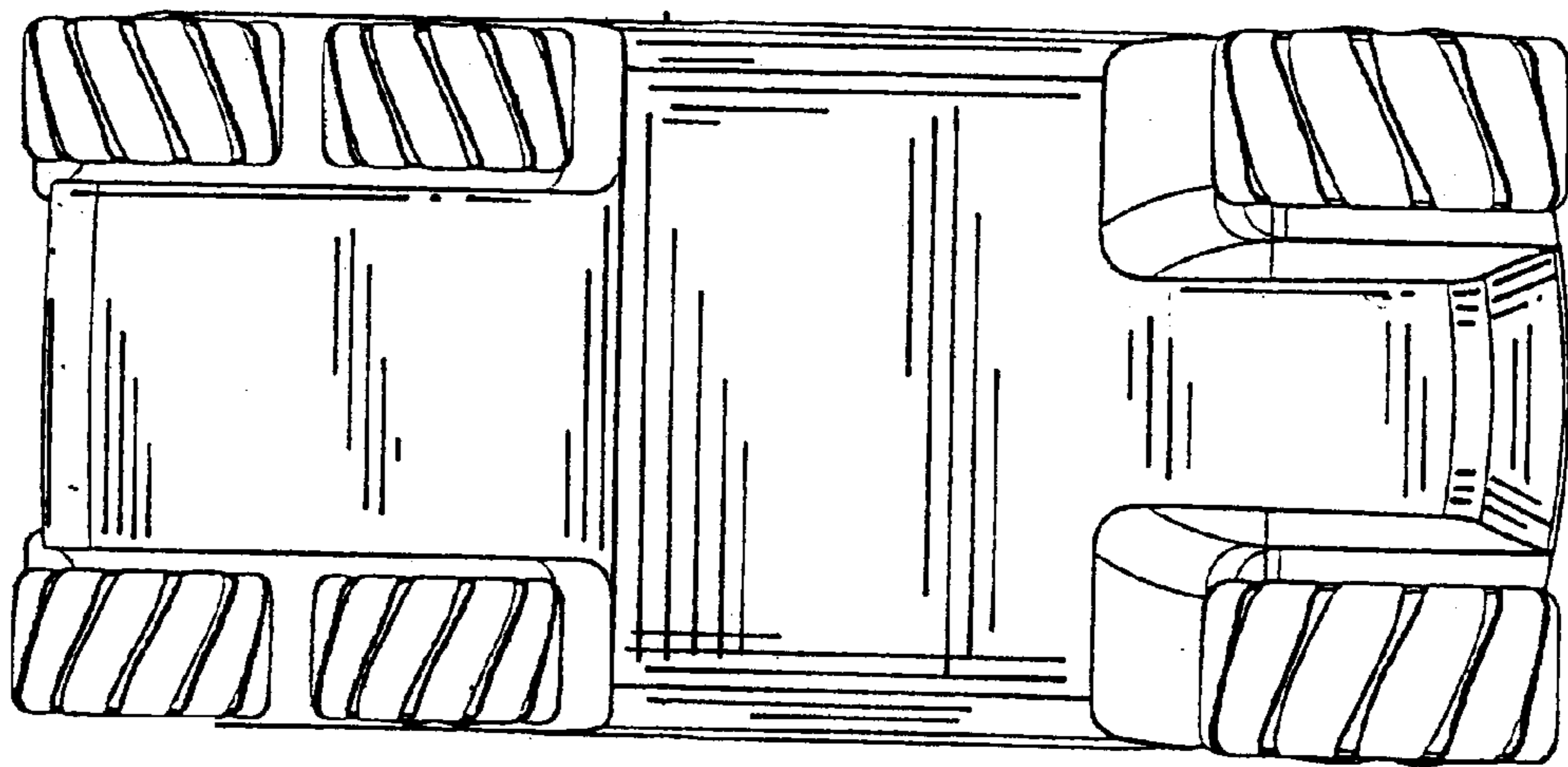

Fig. 16