



US00D449503B1

(12) **United States Design Patent**  
**Tsuzuki et al.**

(10) **Patent No.:** **US D449,503 S**

(45) **Date of Patent:** **\*\* Oct. 23, 2001**

(54) **PORTABLE ELECTRIC CIRCULAR SAW**

(75) Inventors: **Hitoshi Tsuzuki**, Hitachinaka; **Mizuho Nakamura**, Ibaraki-ken, both of (JP)

(73) Assignee: **Hitachi Koki Co., Ltd.**, Tokyo (JP)

(\*\*) Term: **14 Years**

(21) Appl. No.: **29/128,915**

(22) Filed: **Sep. 6, 2000**

(30) **Foreign Application Priority Data**

Mar. 9, 2000 (JP) ..... 12-005102

(51) **LOC (7) Cl.** ..... **08-03**

(52) **U.S. Cl.** ..... **D8/66**

(58) **Field of Search** ..... D8/61-70; 81/57.11,  
81/56, 54, 57.42; 30/376, 377, 387-391

(56) **References Cited**

**U.S. PATENT DOCUMENTS**

D. 320,729	*	10/1991	Zurwelle	.....	D8/66
D. 329,363	*	9/1992	Sasaki et al.	.....	D8/66
D. 378,488	*	3/1997	Ito et al.	.....	D8/66
D. 408,248	*	4/1999	Zurwelle et al.	.....	D8/66
D. 416,181	*	11/1999	Chung	.....	D8/66
D. 421,702	*	3/2000	Sakai et al.	.....	D8/66
D. 428,318	*	7/2000	Gallagher et al.	.....	D8/66
D. 428,319	*	7/2000	Gallagher	.....	D8/66
D. 433,300	*	11/2000	Buck	.....	D8/66
4,516,324	*	5/1985	Heininger, Jr. et al.	.....	30/377

4,856,394	*	8/1989	Clowers	.....	83/56
5,010,651	*	4/1991	Techter et al.	.....	303/76
5,375,495	*	12/1994	Bosten et al.	.....	83/520
5,794,351	*	8/1998	Campbell et al.	.....	30/390
5,911,482	*	6/1999	Campbell et al.	.....	30/390

\* cited by examiner

*Primary Examiner*—Jeffrey Asch

(74) *Attorney, Agent, or Firm*—McDermott, Will & Emery

(57) **CLAIM**

The ornamental design for a portable electric circular saw, as shown and described.

**DESCRIPTION**

FIG. 1 is a photograph corresponding to a front elevational view of the portable electric circular saw;

FIG. 2 is a photograph corresponding to a rear elevational view thereof;

FIG. 3 is a photograph corresponding to a left side view thereof;

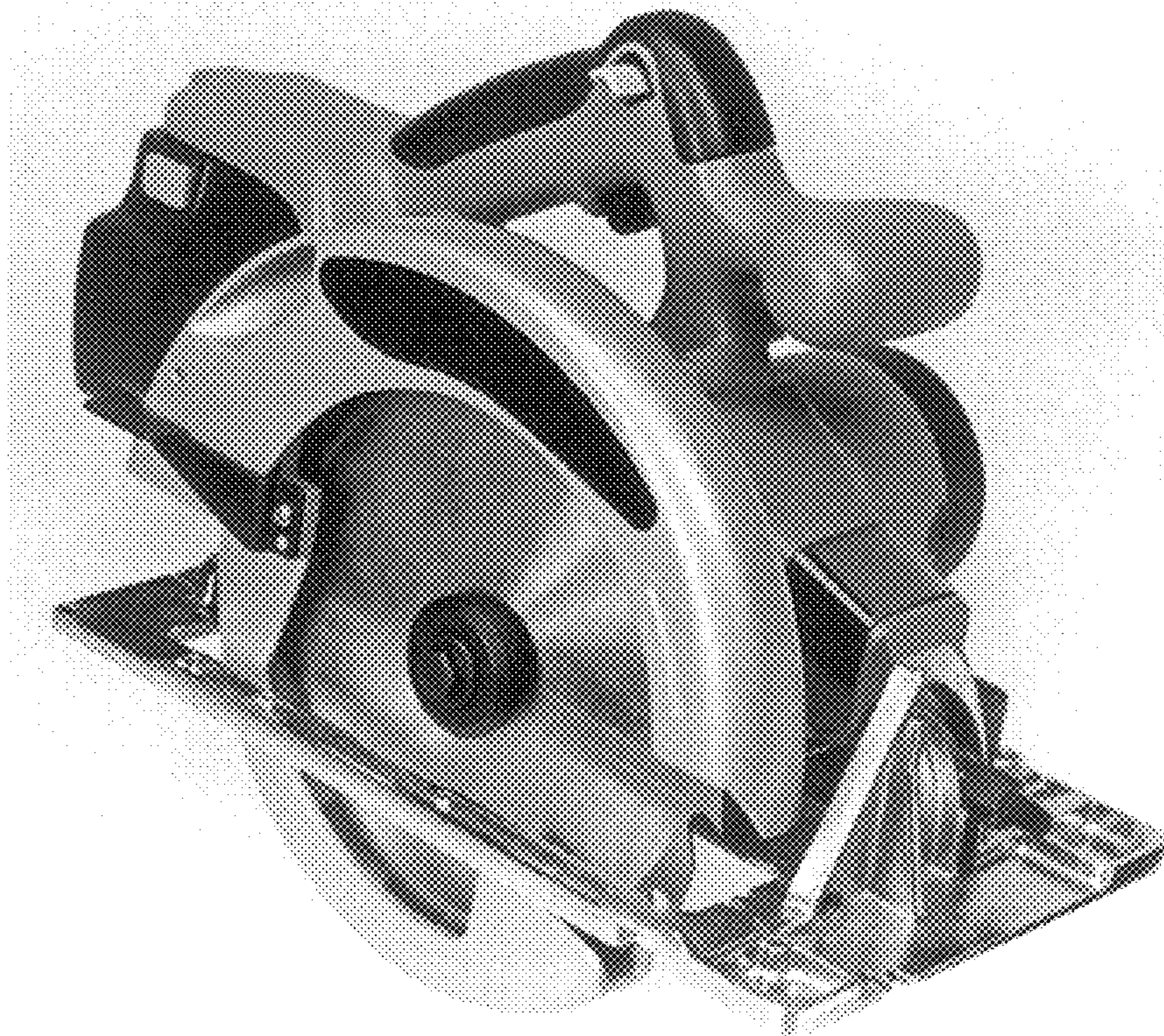
FIG. 4 is a photograph corresponding to a right side view thereof;

FIG. 5 is a photograph corresponding to a top plan view thereof;

FIG. 6 is a photograph corresponding to a bottom plan view thereof; and,

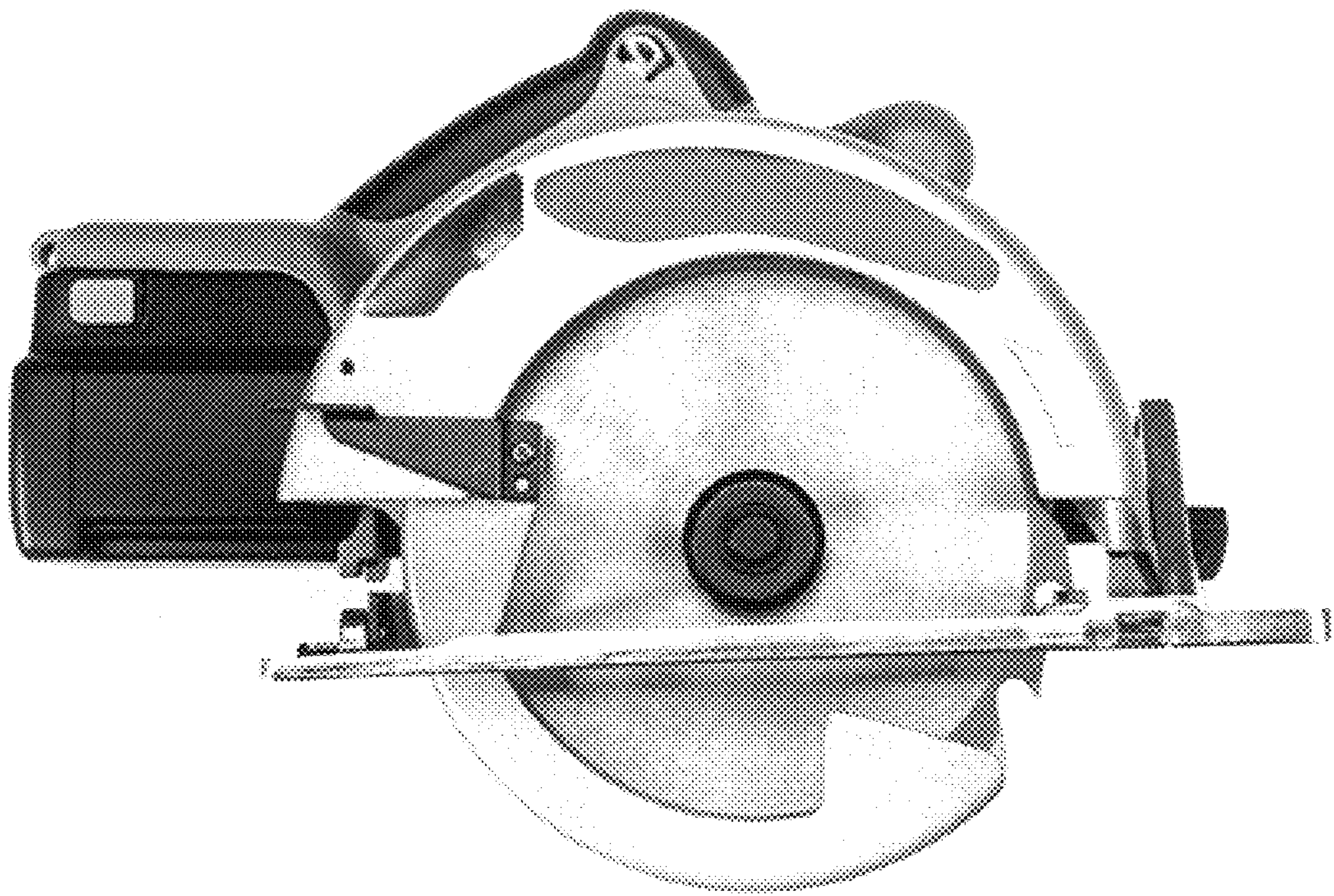
FIG. 7 is a photograph corresponding to a front perspective view thereof.

**1 Claim, 7 Drawing Sheets**



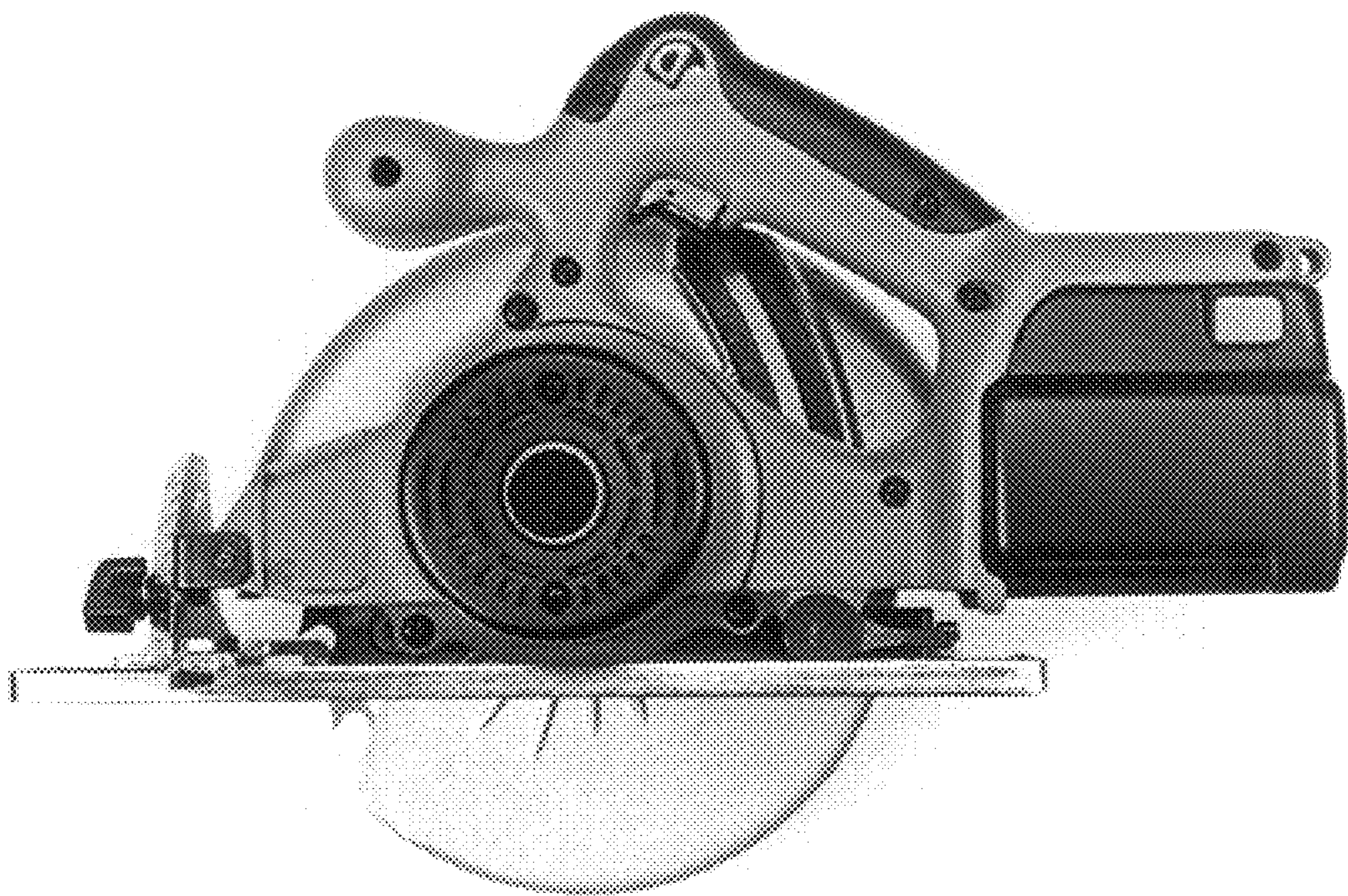


*FIG. 1*



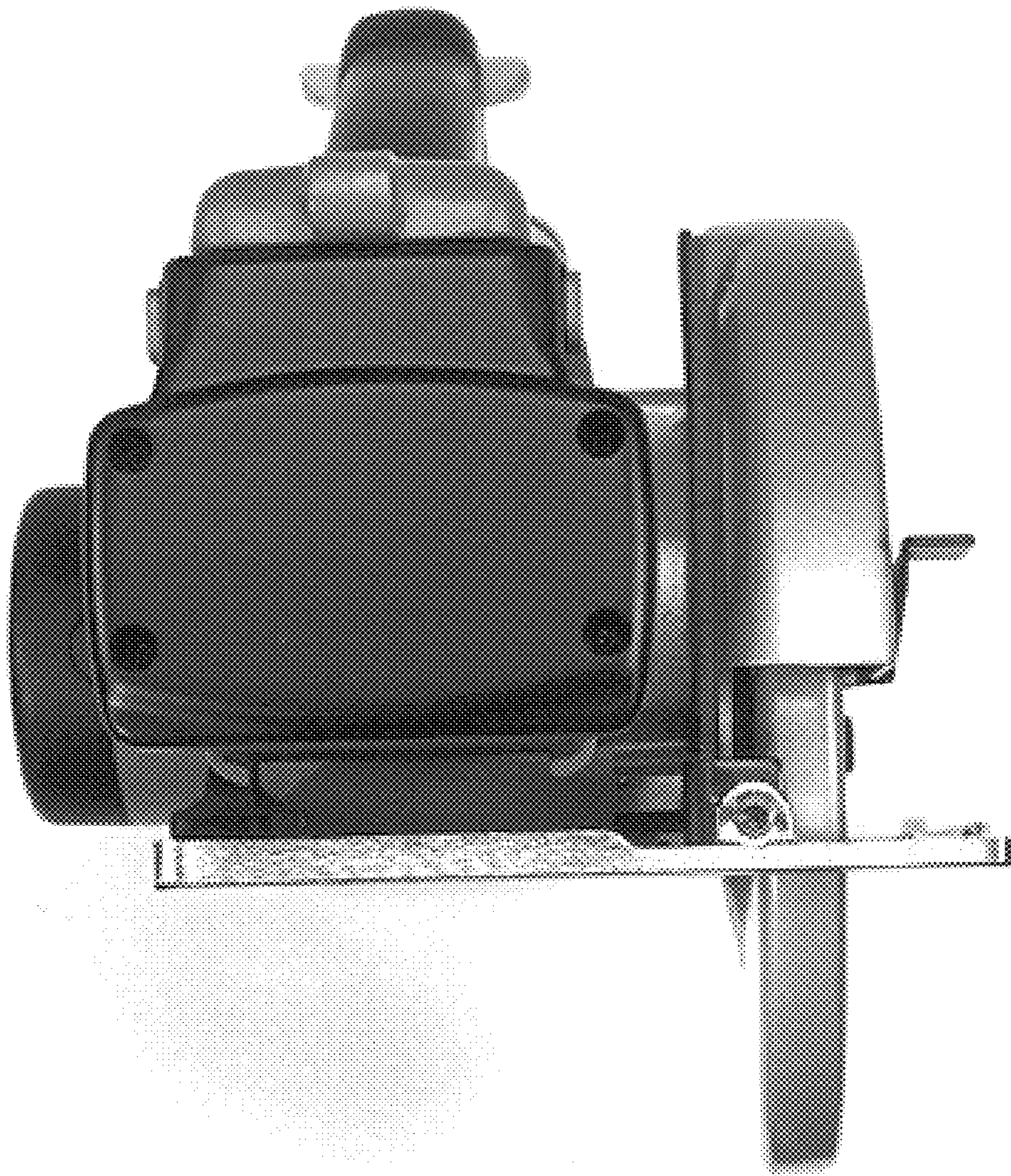


*FIG. 2*



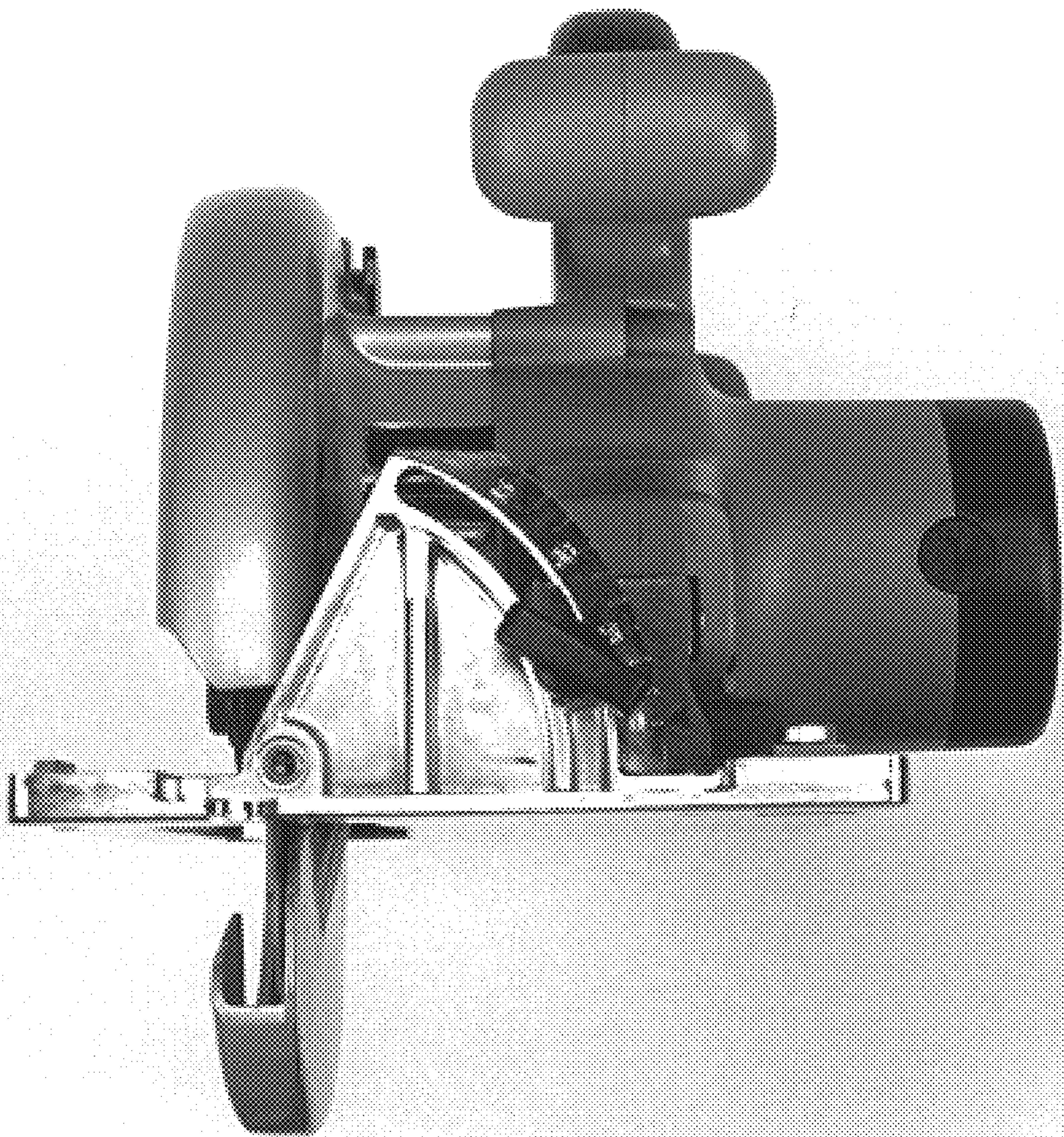


*FIG. 3*



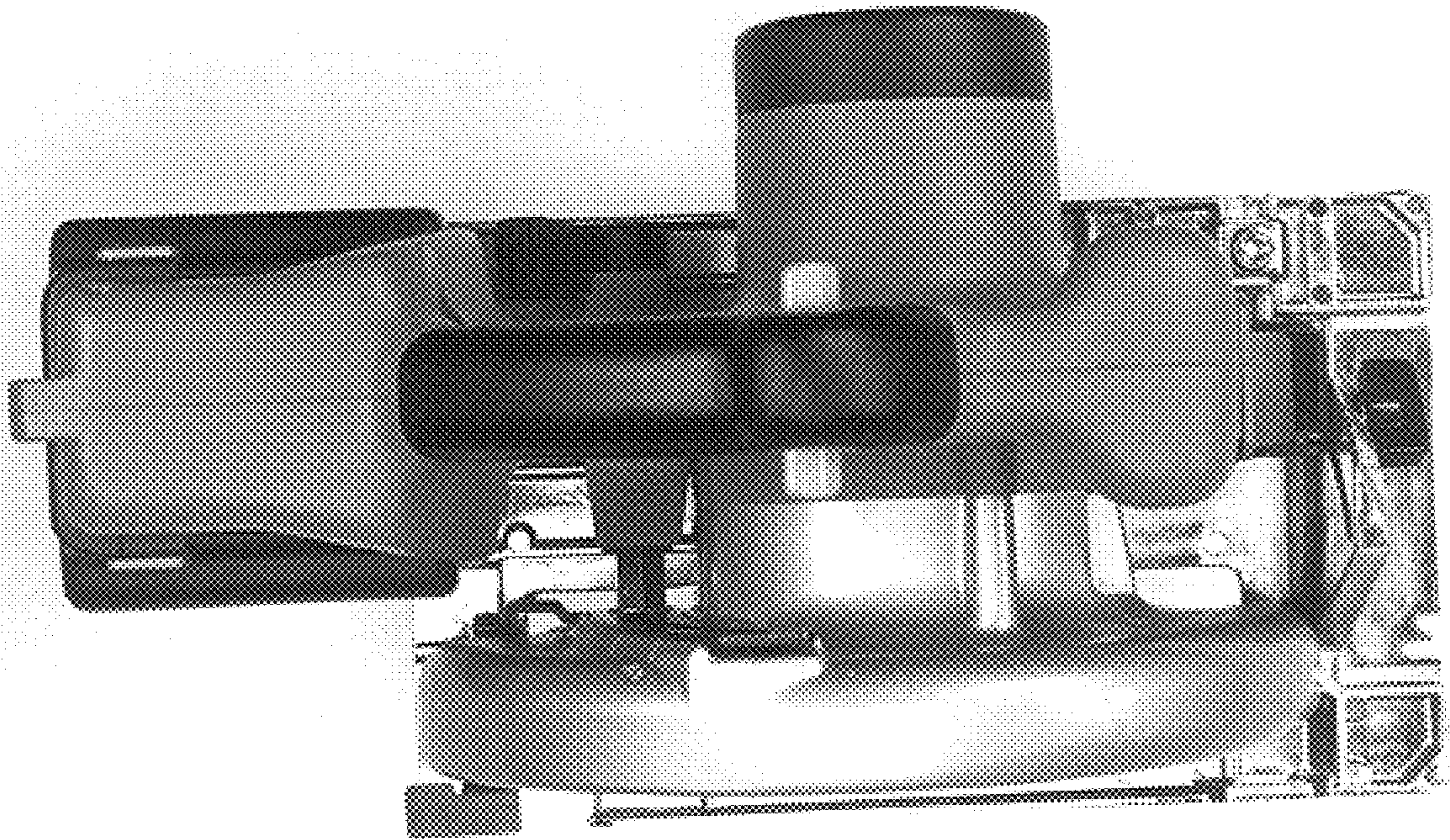


*FIG. 4*



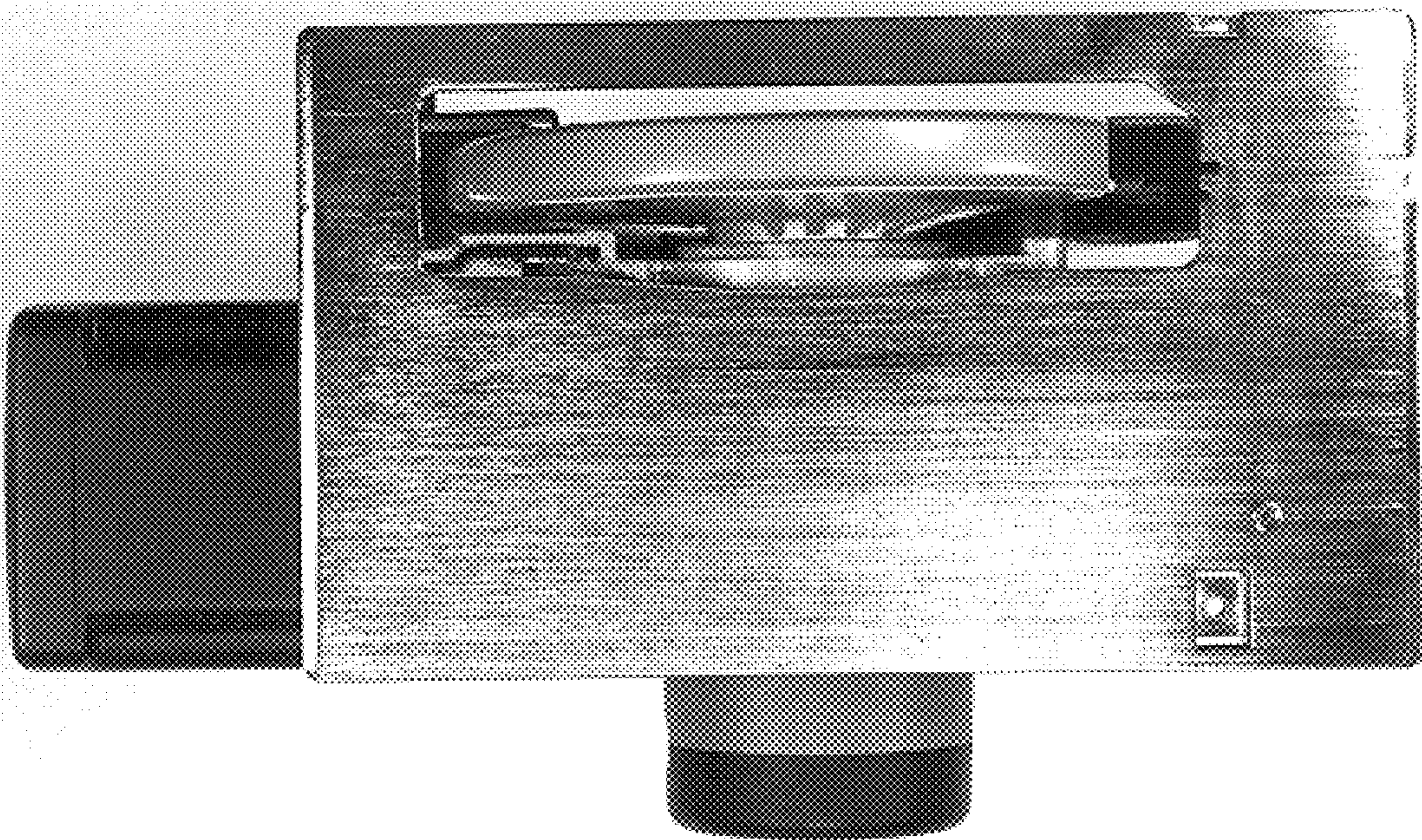


*FIG. 5*





*FIG. 6*





*FIG. 7*

