



US00D449255B1

(12) **United States Design Patent**
Rajkai et al.

(10) **Patent No.:** **US D449,255 S**

(45) **Date of Patent:** **** Oct. 16, 2001**

(54) **COLLAPSIBLE, PEDAL-PROPELLED VEHICLE**

(76) Inventors: **Tibor Rajkai**, Szechenyi U 47, Komarom (HU); **Lee Nemeth**, 60 Candee Rd., Prospect, CT (US) 06712

(**) Term: **14 Years**

(21) Appl. No.: **29/132,669**

(22) Filed: **Nov. 9, 2000**

(51) **LOC (7) Cl.** **12-11**

(52) **U.S. Cl.** **D12/111**

(58) **Field of Search** D12/107, 111; D21/663, 432, 423; 280/270, 274, 281.1, 288.1-288.3, 283-288, 87.041; 180/219, 65.1, 220, 180, 181

(56) **References Cited**

U.S. PATENT DOCUMENTS

5,775,708 * 7/1998 Heath 280/270 X

* cited by examiner

Primary Examiner—Alan P. Douglas

Assistant Examiner—Linda Brooks

(74) *Attorney, Agent, or Firm*—Melvin I. Stoltz

(57) **CLAIM**

The ornamental design for a collapsible, pedal-propelled vehicle, as shown and described.

DESCRIPTION

FIG. 1 is a side elevational view of the collapsible, pedal-propelled vehicle showing our new design, looking from the left side of FIG. 2;

FIG. 2 is a front elevational thereof;

FIG. 3 is a side elevational view thereof, looking from the right side of FIG. 2;

FIG. 4 is a rear elevational view thereof;

FIG. 5 is a top plan view thereof; and,

FIG. 6 is a side elevational view thereof showing the collapsible, pedal-propelled vehicle in its collapsed position.

1 Claim, 3 Drawing Sheets

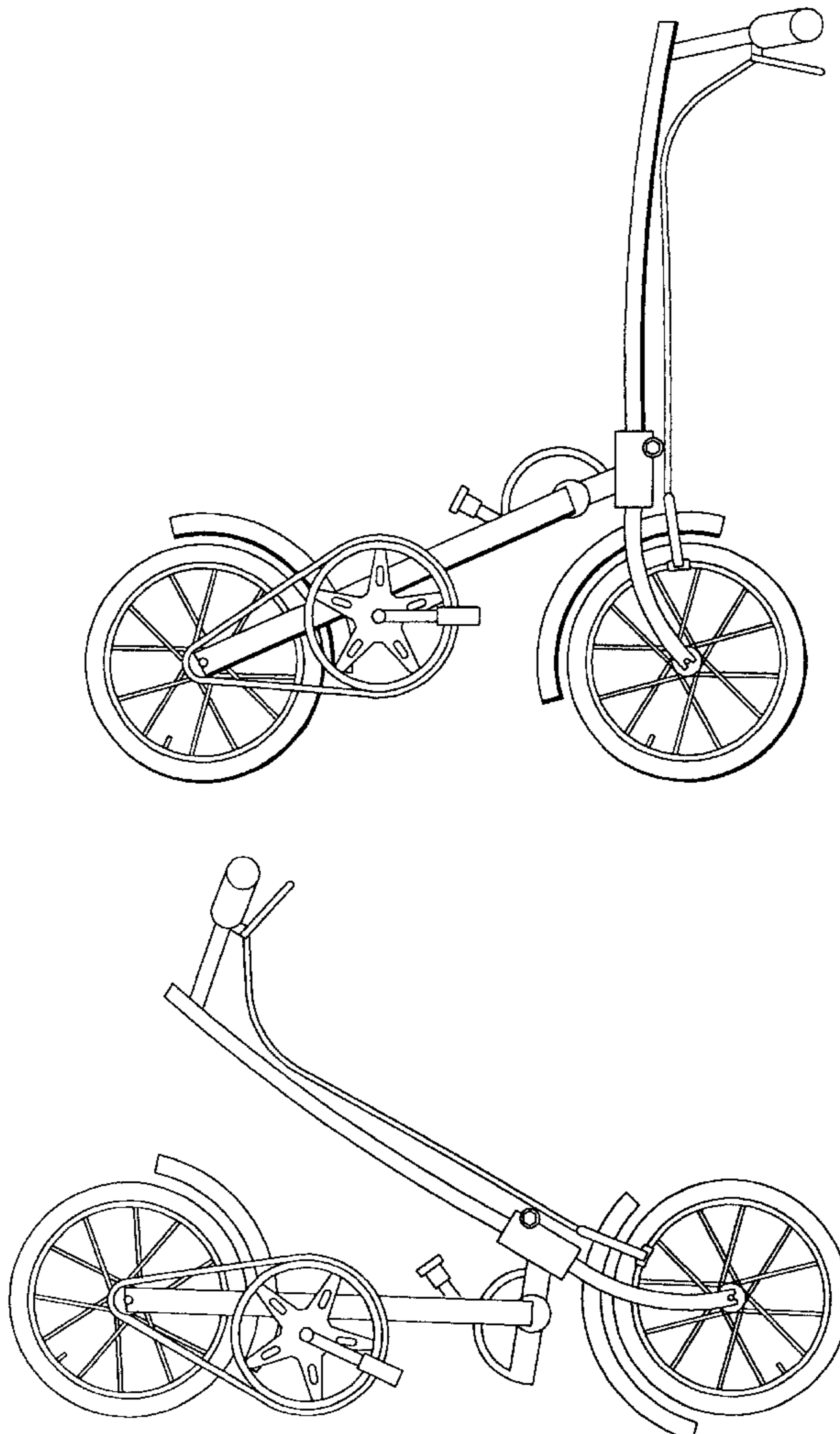

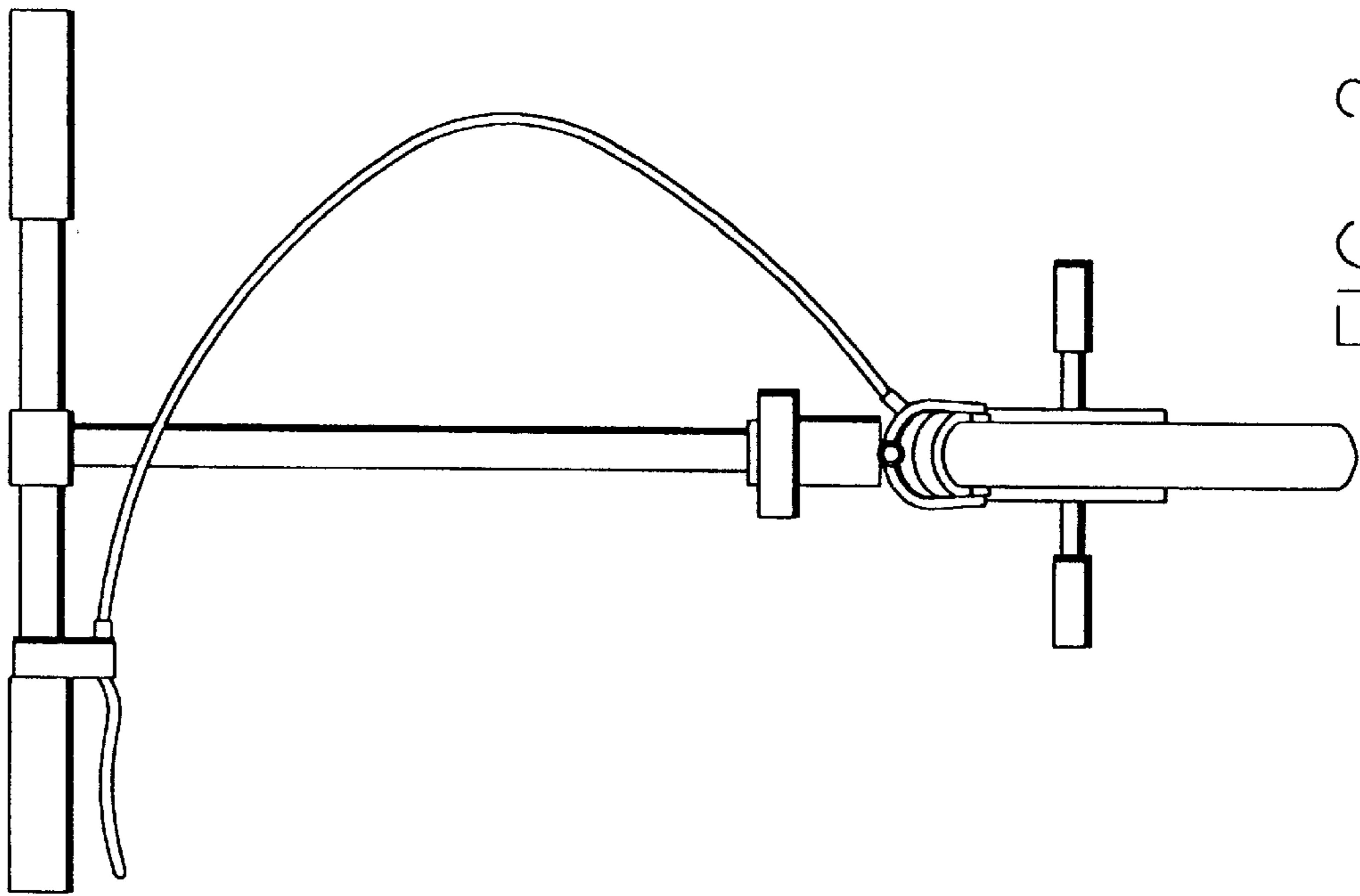

FIG. 2

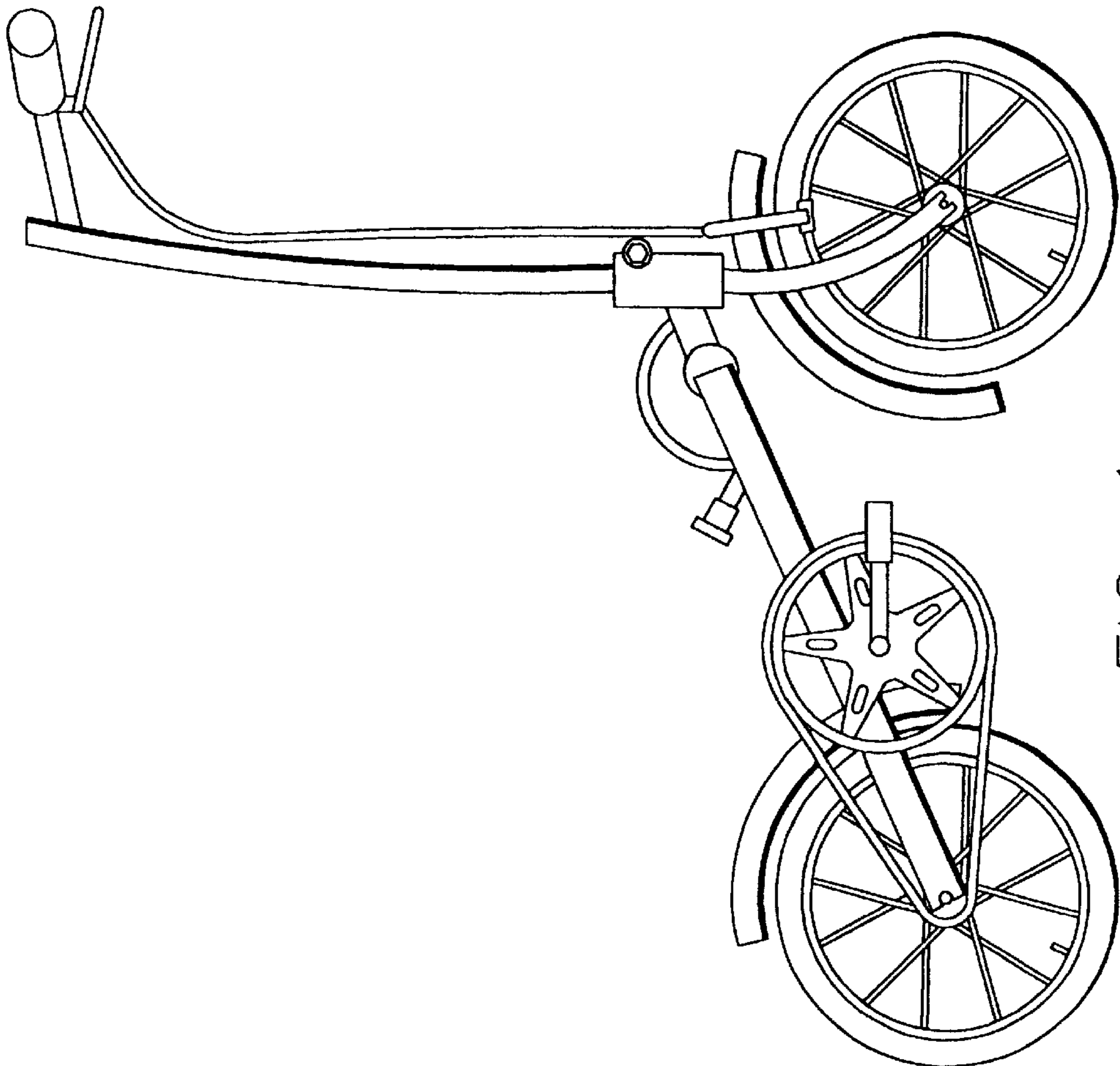

FIG. 1

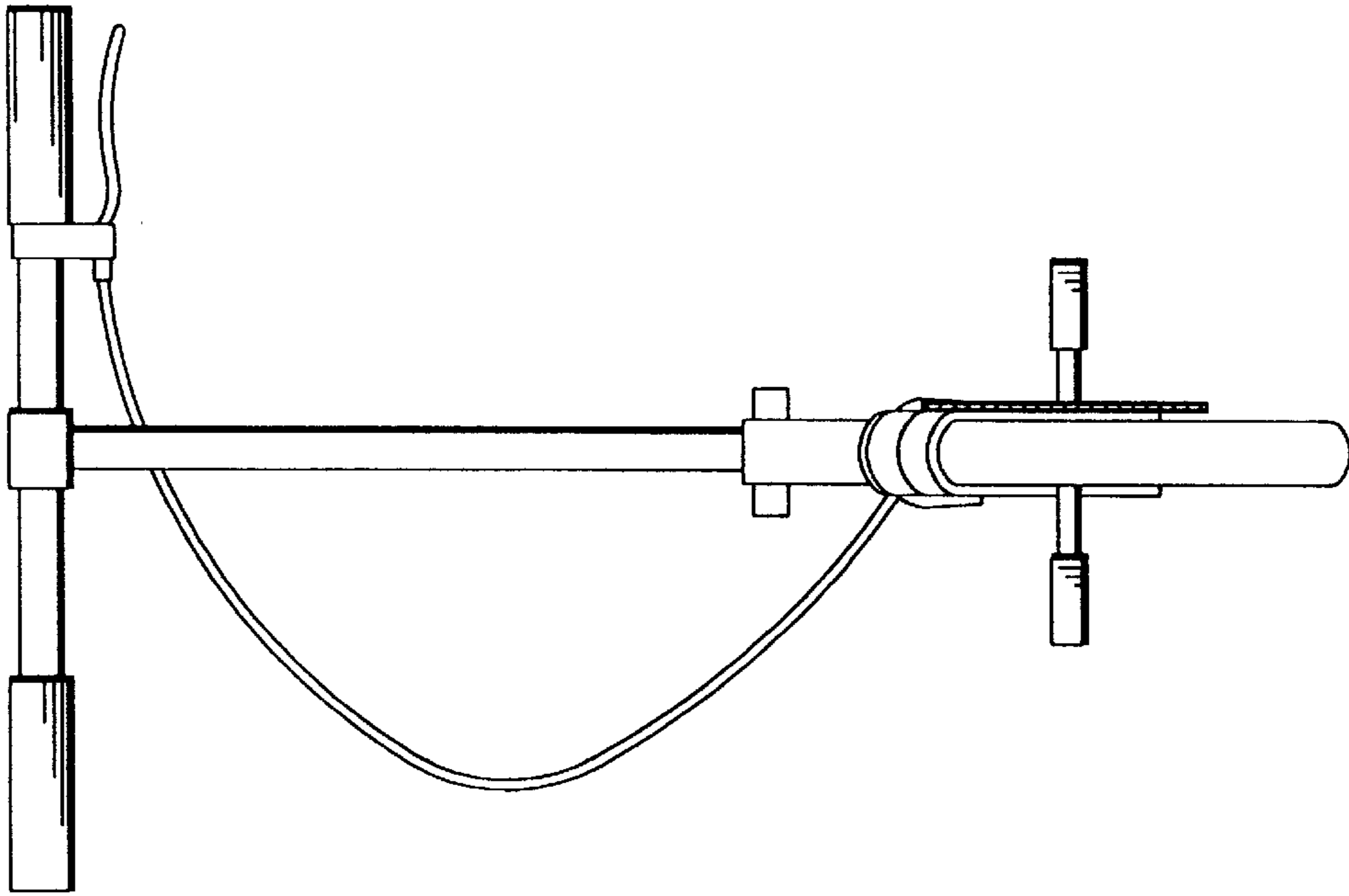

FIG. 4

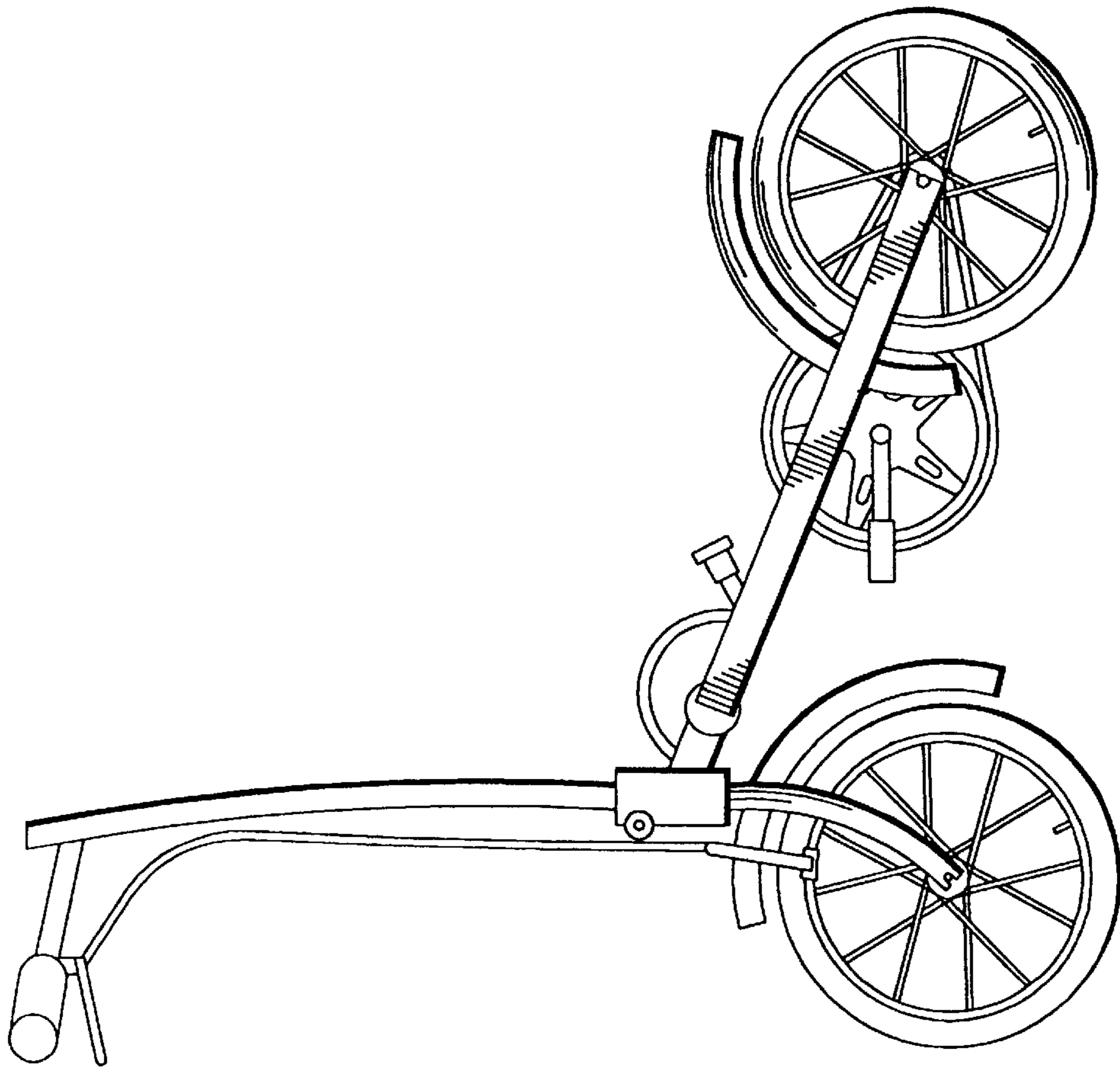

FIG. 3

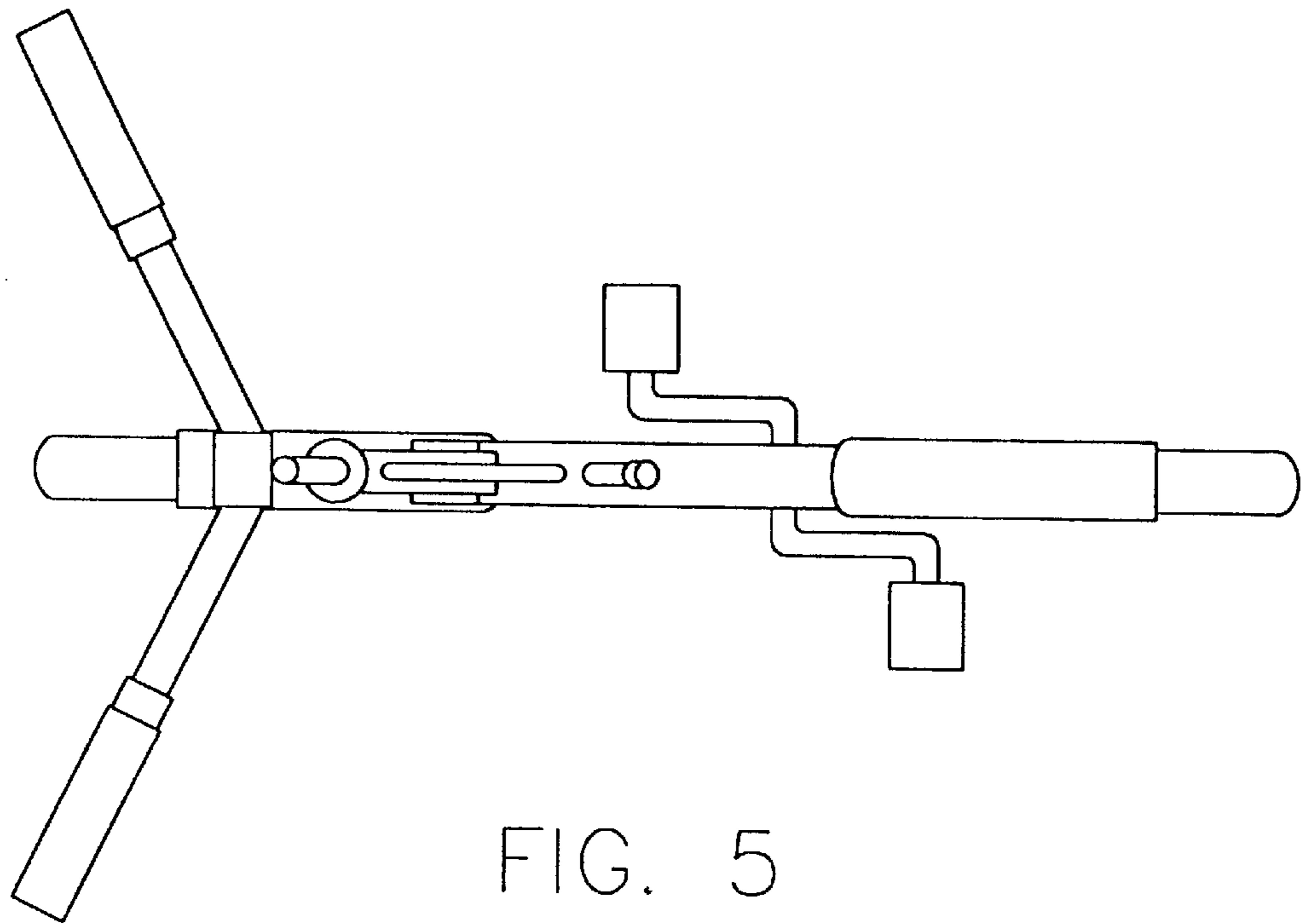

FIG. 5

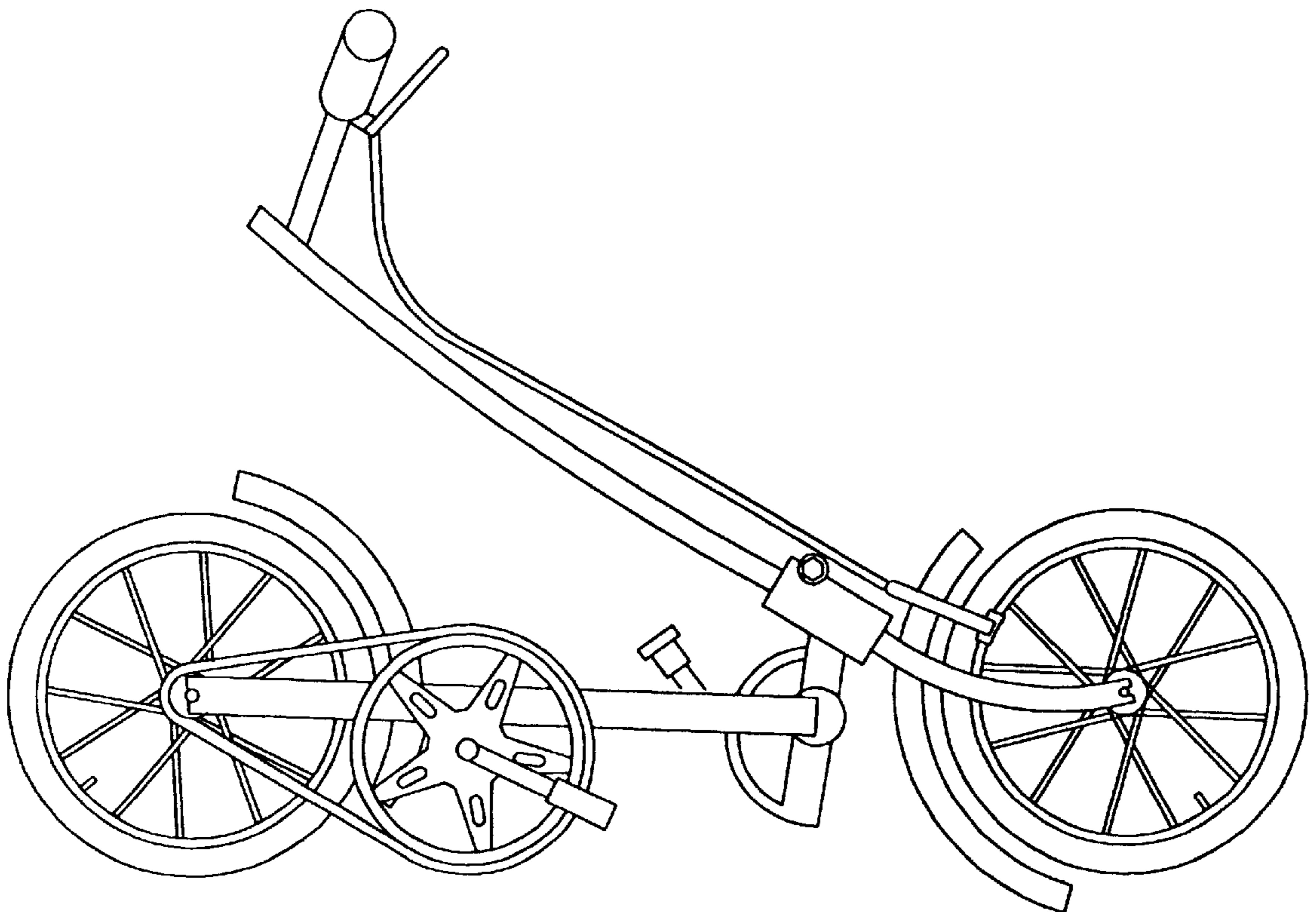

FIG. 6