



US00D449252B1

(12) **United States Design Patent**
Takeshita et al.

(10) **Patent No.: US D449,252 S**

(45) **Date of Patent: ** Oct. 16, 2001**

(54) **TRACKED VEHICLE**

(75) Inventors: **Kaz Takeshita**, Irvine; **Joo Ho Paek**,
Cerritos, both of CA (US)

(73) Assignee: **Bombardier Inc.**, Montreal (CA)

(**) Term: **14 Years**

(21) Appl. No.: **29/106,381**

(22) Filed: **Jun. 15, 1999**

(30) **Foreign Application Priority Data**

Dec. 15, 1998 (CA) 1998-3047

(51) **LOC (7) Cl.** **12-14**

(52) **U.S. Cl.** **D12/11**

(58) **Field of Search** D15/10-12, 30,
D15/33; D12/1, 7, 12; 296/190.09, 190.01,
190.08, 190.11; 362/485, 493; 180/7.1,
90, 89.12, 89.1, 89.19, 9.1; 37/196, 225,
219, 224, 263

(56) **References Cited**

U.S. PATENT DOCUMENTS

- D. 222,859 * 1/1972 Delisle et al. .
- D. 237,373 * 10/1975 Cole et al. .

(List continued on next page.)

OTHER PUBLICATIONS

BR-180 Brochure, Bombardier Services, Granby, Quebec,
Canada, 1996. (first introduced as BR-160 in 1992).

(List continued on next page.)

Primary Examiner—B. J. Bullock

(74) *Attorney, Agent, or Firm*—Pillsbury Winthrop LLP

(57) **CLAIM**

We claim the ornamental design for a tracked vehicle, as
shown and described.

DESCRIPTION

FIG. 1 is a front perspective view of a first variant of
bodywork of the tracked vehicle according to the present
design;

FIG. 2 is a left side elevation view of the tracked vehicle
according to the present design;

FIG. 3 is a rear perspective view of the bodywork of the
tracked vehicle of FIG. 2;

FIG. 4 is a right side elevation view of the bodywork of the
tracked vehicle of FIG. 2;

FIG. 5 is a front elevation view of the bodywork of the
tracked vehicle of FIG. 2;

FIG. 6 is a rear elevation view of the bodywork of the
tracked vehicle of FIG. 2;

FIG. 7 is a top plan view of the bodywork of the tracked
vehicle of FIG. 2;

FIG. 8 is a front perspective view of a second variant of the
bodywork of the tracked vehicle according to the present
design;

FIG. 9 is a left side elevation view of the bodywork of the
tracked vehicle of FIG. 8;

FIG. 10 is a rear perspective view of the bodywork of the
tracked vehicle of FIG. 8;

FIG. 11 is a right side elevation view of the bodywork of the
tracked vehicle of FIG. 8;

FIG. 12 is a front elevation view of the bodywork of the
tracked vehicle of FIG. 8;

FIG. 13 is a rear elevation view of the bodywork of the
tracked vehicle of FIG. 8;

FIG. 14 is a top plan view of the bodywork of the tracked
vehicle of FIG. 8;

FIG. 15 is a front perspective view of a third variant of the
bodywork of the tracked vehicle according to the present
design;

FIG. 16 is a left side elevation view of the bodywork of the
tracked vehicle of FIG. 15;

FIG. 17 is a rear perspective view of the bodywork of the
tracked vehicle of FIG. 15;

FIG. 18 is a right side elevation view of the bodywork of the
tracked vehicle of FIG. 15;

FIG. 19 is a front elevation view of the bodywork of the
tracked vehicle of FIG. 15;

FIG. 20 is a rear elevation view of the bodywork of the
tracked vehicle of FIG. 15; and,

FIG. 21 is a top plan view of the bodywork of the tracked
vehicle of FIG. 15.

The broken lines immediately adjacent to the cab represent
the bounds of the design while all other broken lines
represent environment. None of the broken lines form a part
of the claimed design.

1 Claim, 10 Drawing Sheets

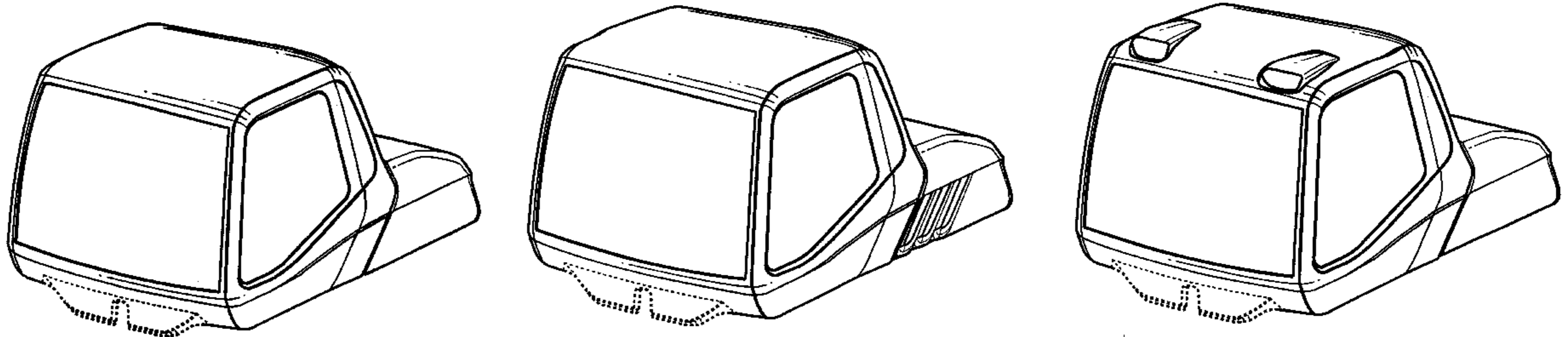

US D449,252 S

Page 2

U.S. PATENT DOCUMENTS

D. 253,174 * 10/1979 Masar D15/12
D. 274,801 * 7/1984 Griffin et al. D12/7
D. 310,531 * 9/1990 Le Poix D15/11
D. 314,388 * 2/1991 Brewer et al. D15/24
D. 384,358 * 9/1997 Smith D15/30
D. 398,616 * 9/1998 Kwak et al. D15/30
4,202,118 * 5/1980 Held .

5,171,083 * 12/1992 Rich .
5,368,115 * 11/1994 Crabb 180/9.1

OTHER PUBLICATIONS

BR Plus Brochure, Bombardier Services, Granby, Quebec,
Canada, 1996.

* cited by examiner

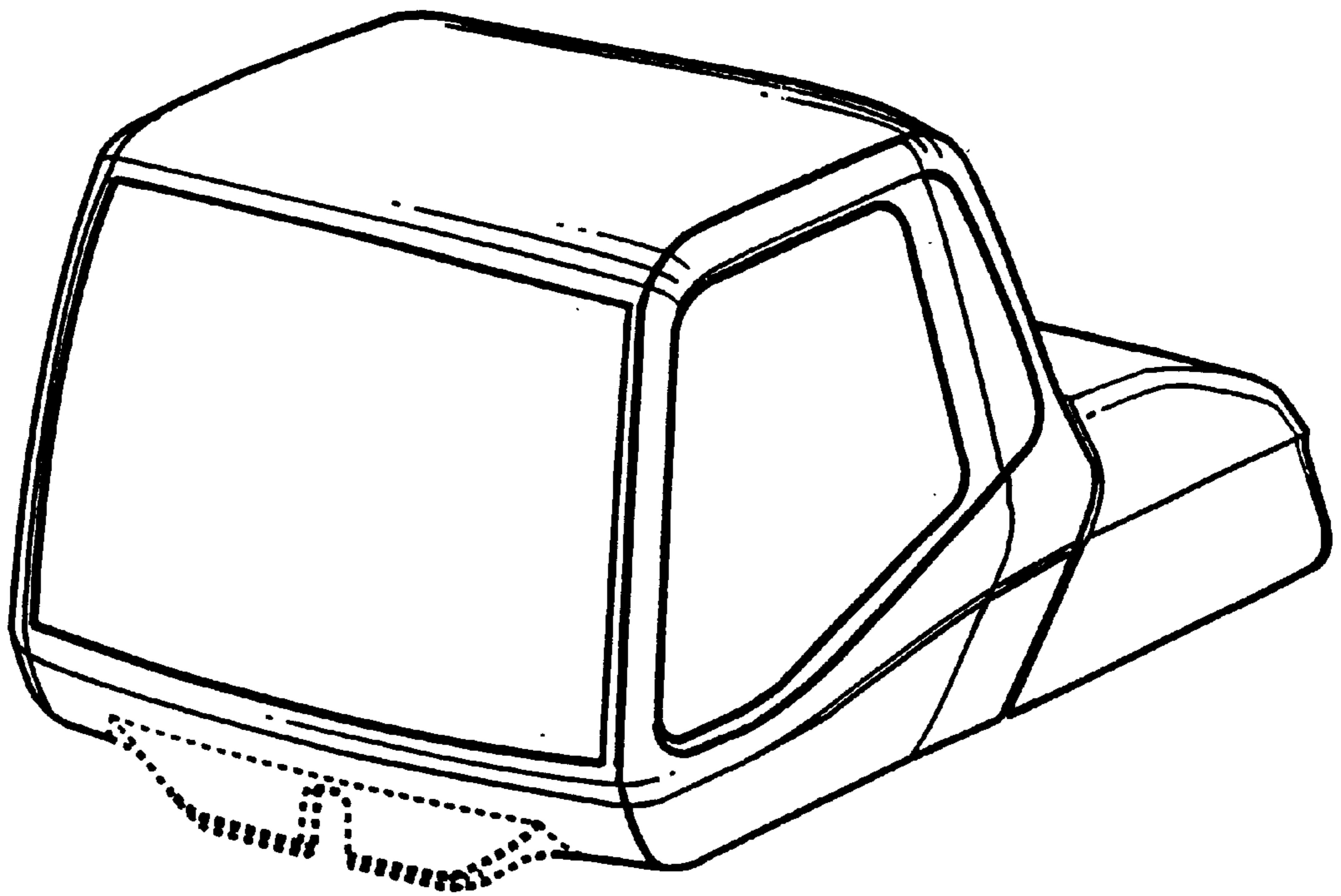

Fig. 1

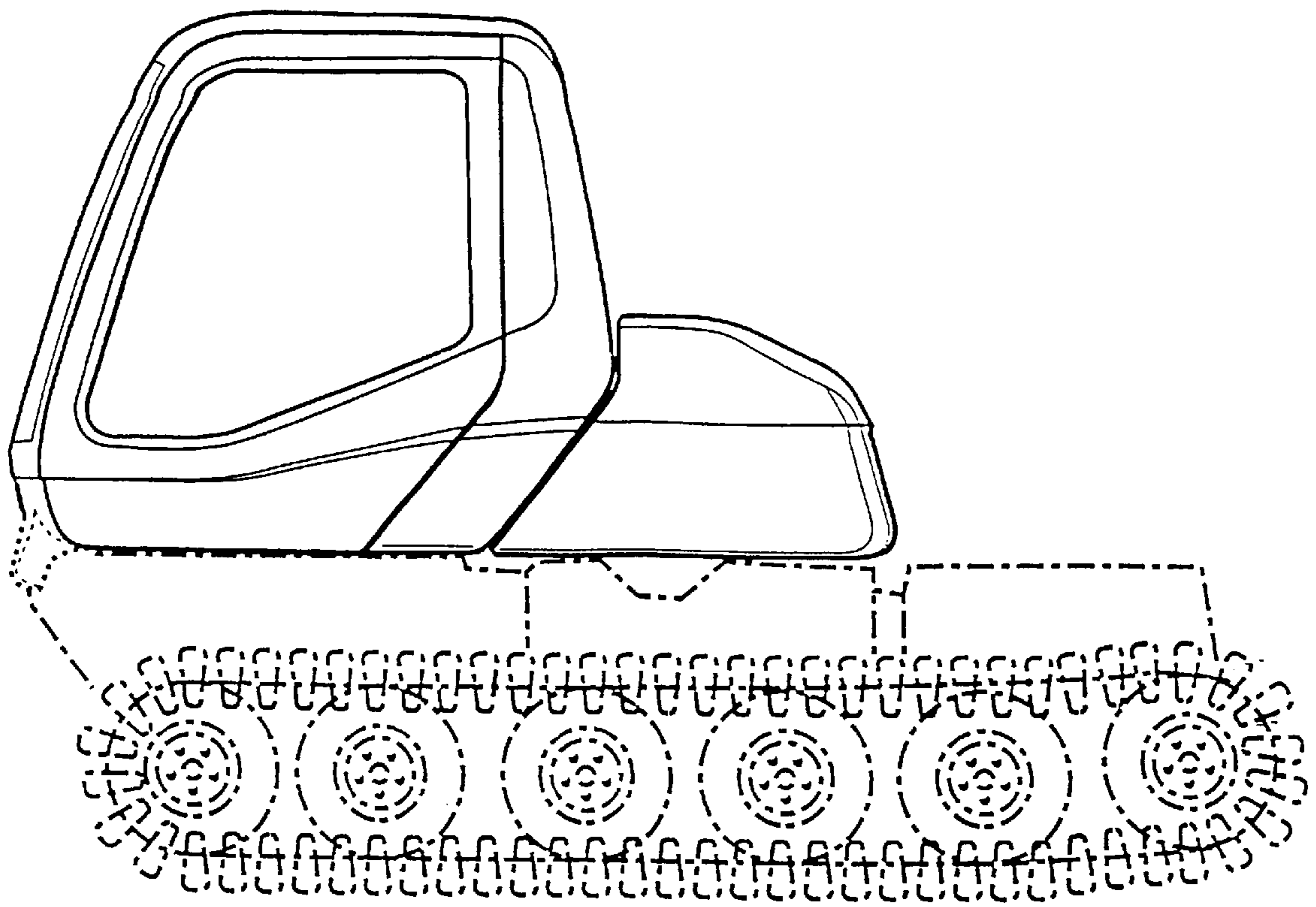

Fig.2

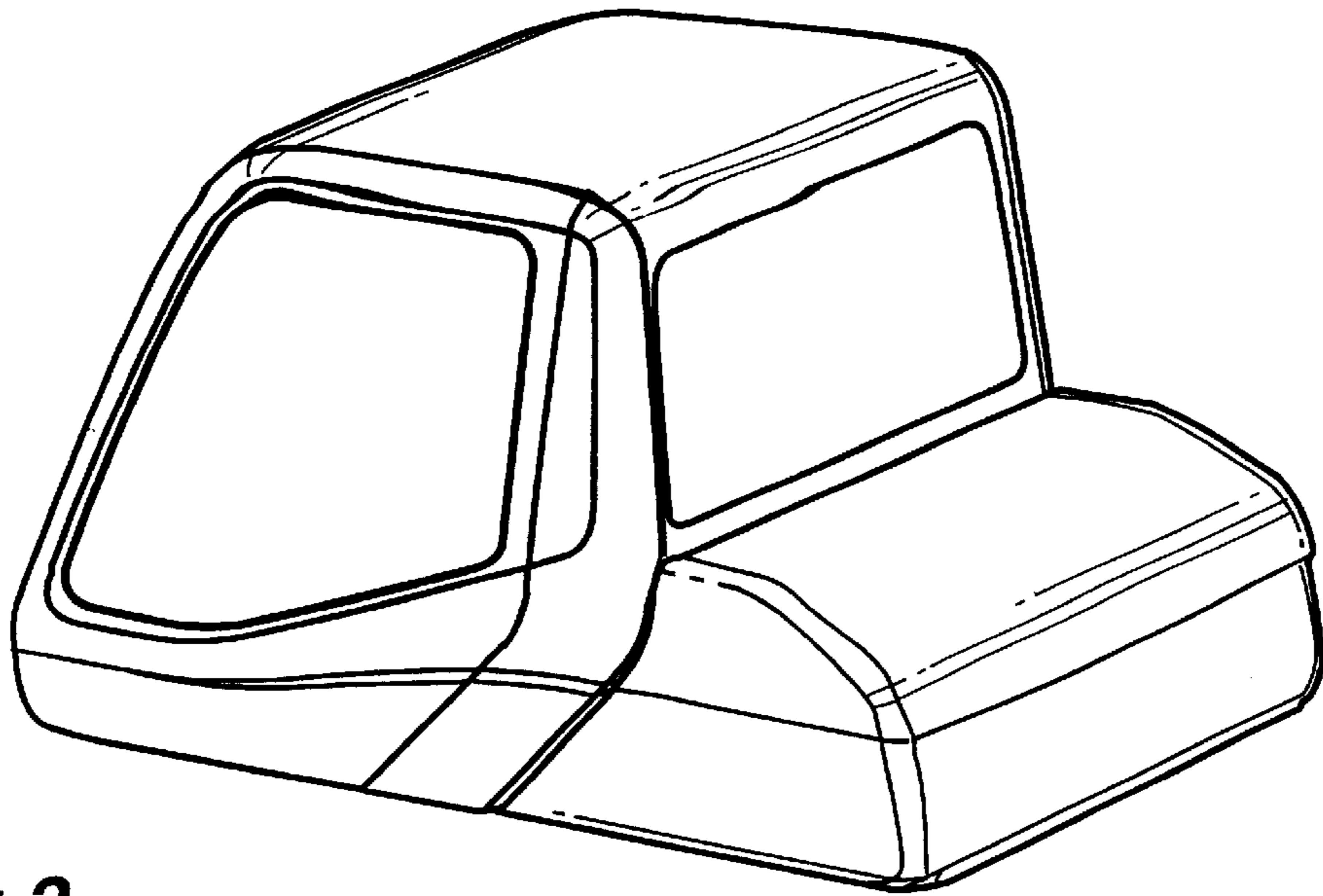

Fig.3

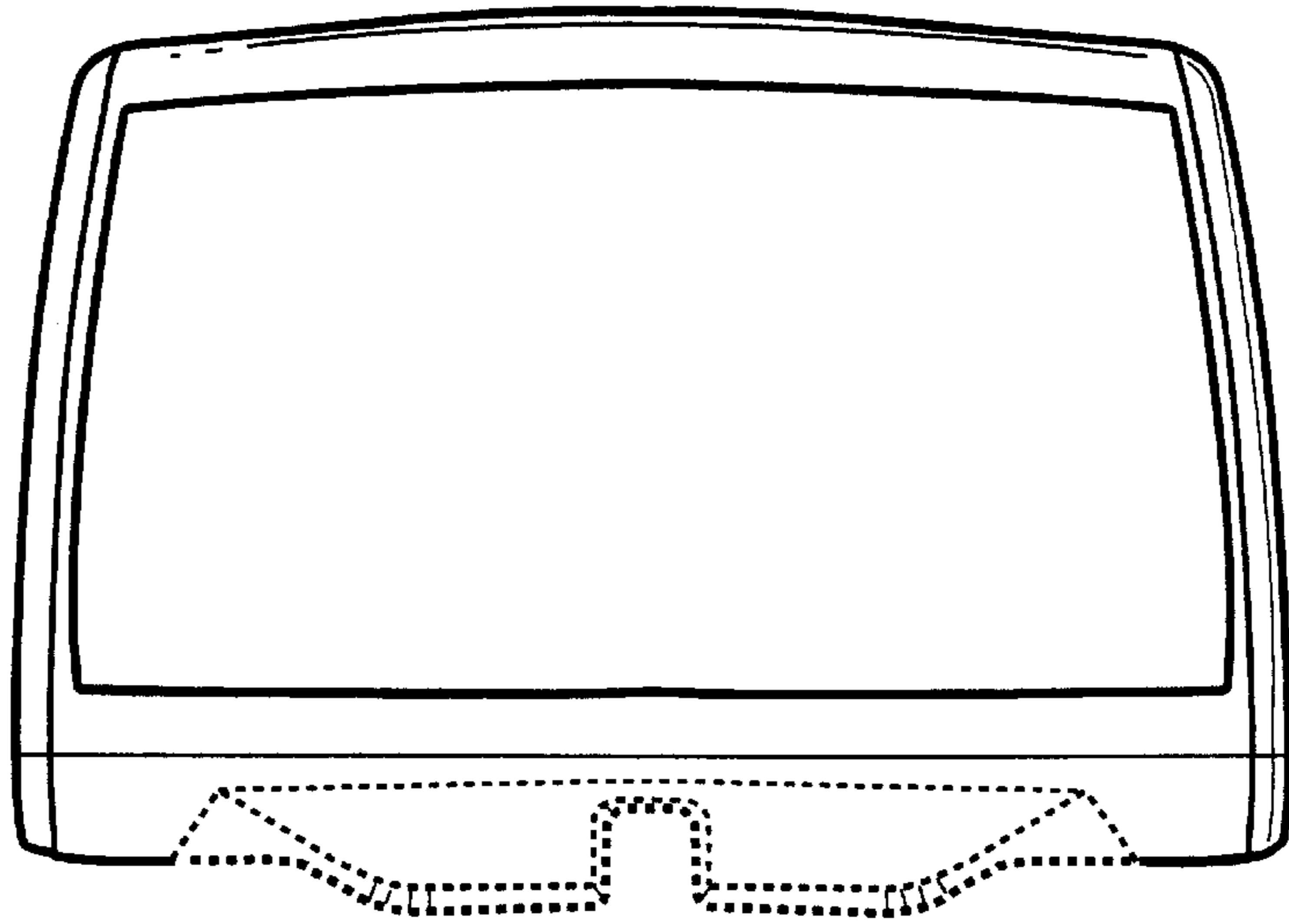

Fig.5

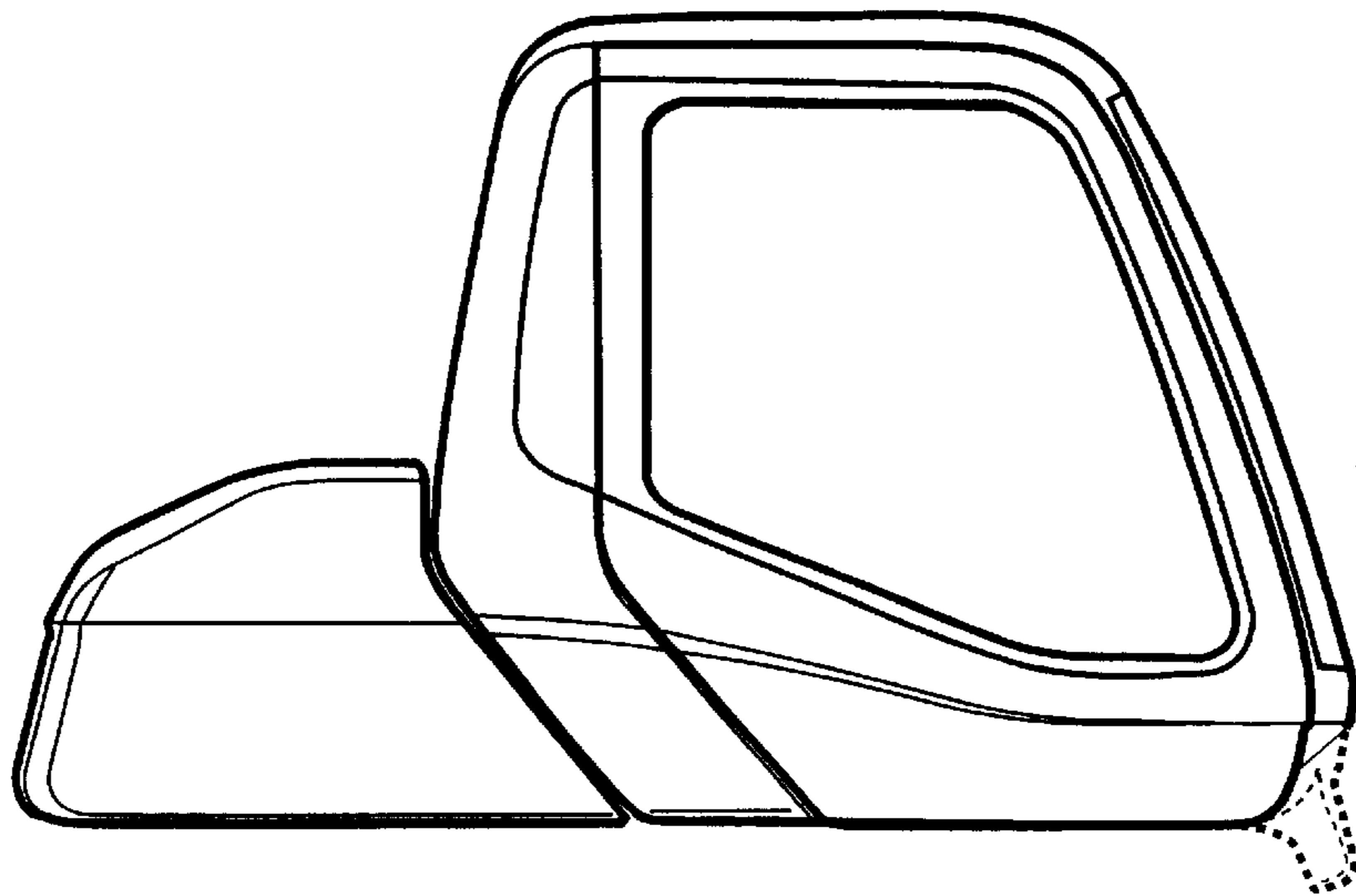

Fig.4

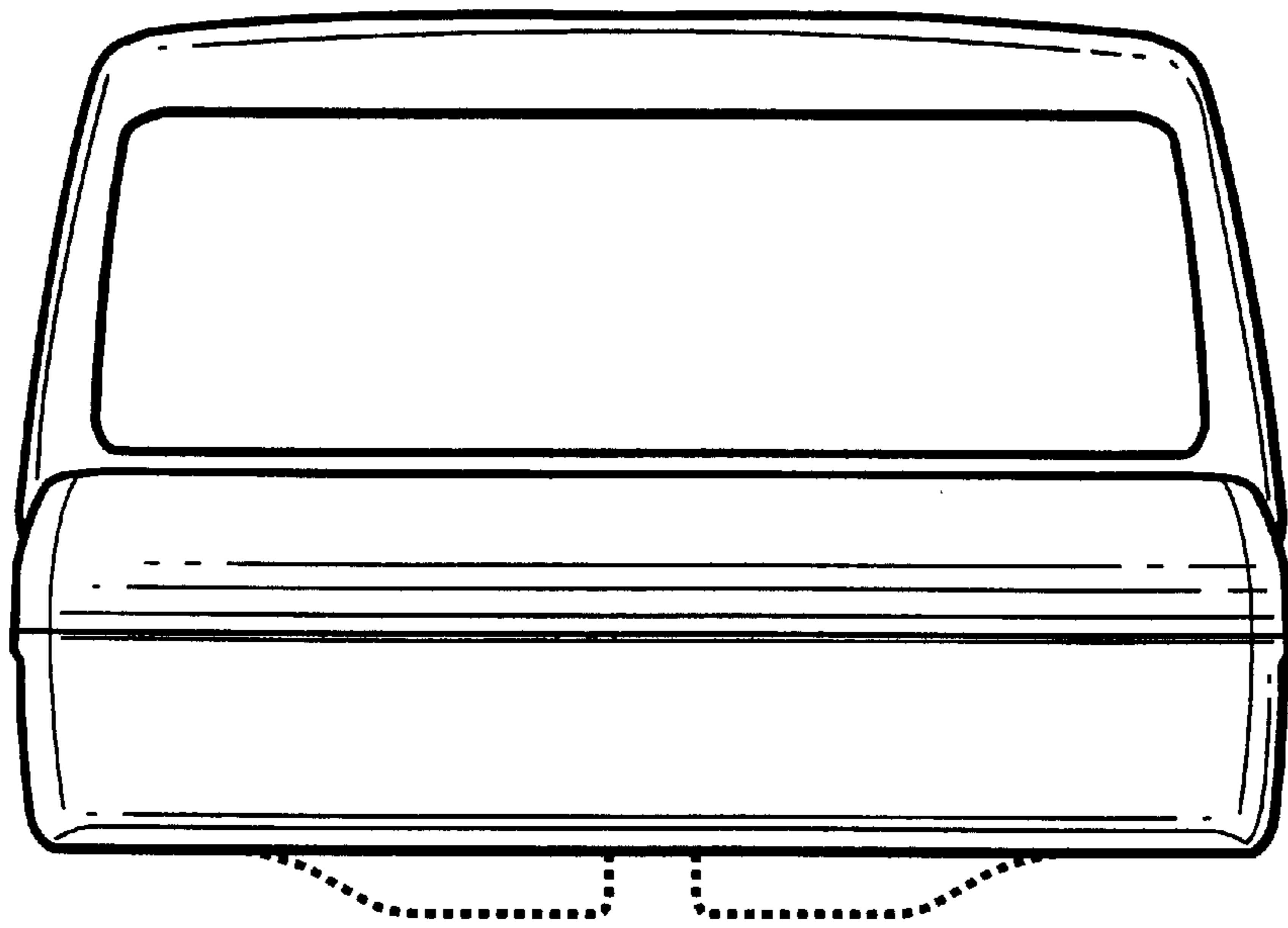

Fig.6

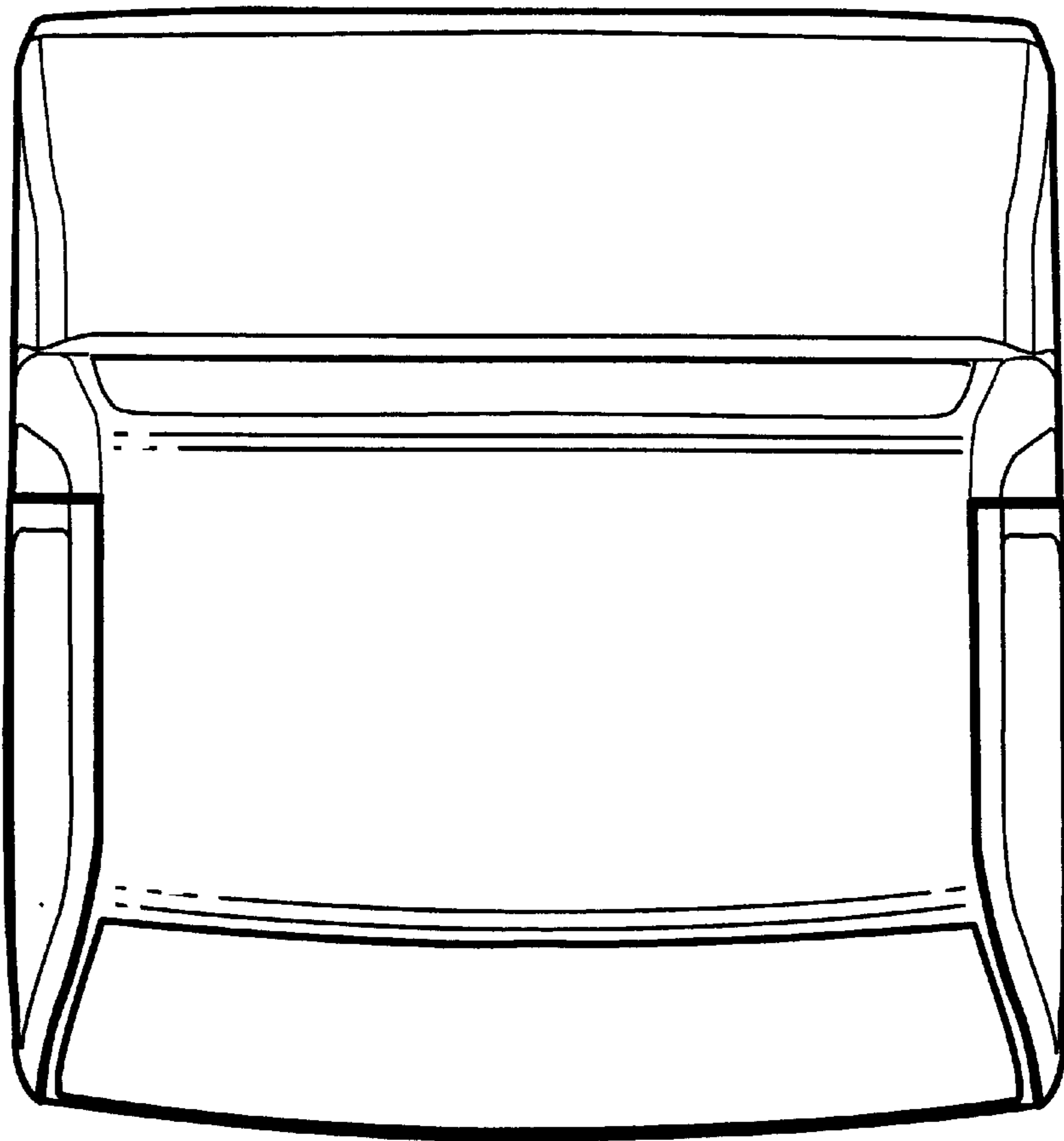

Fig.7

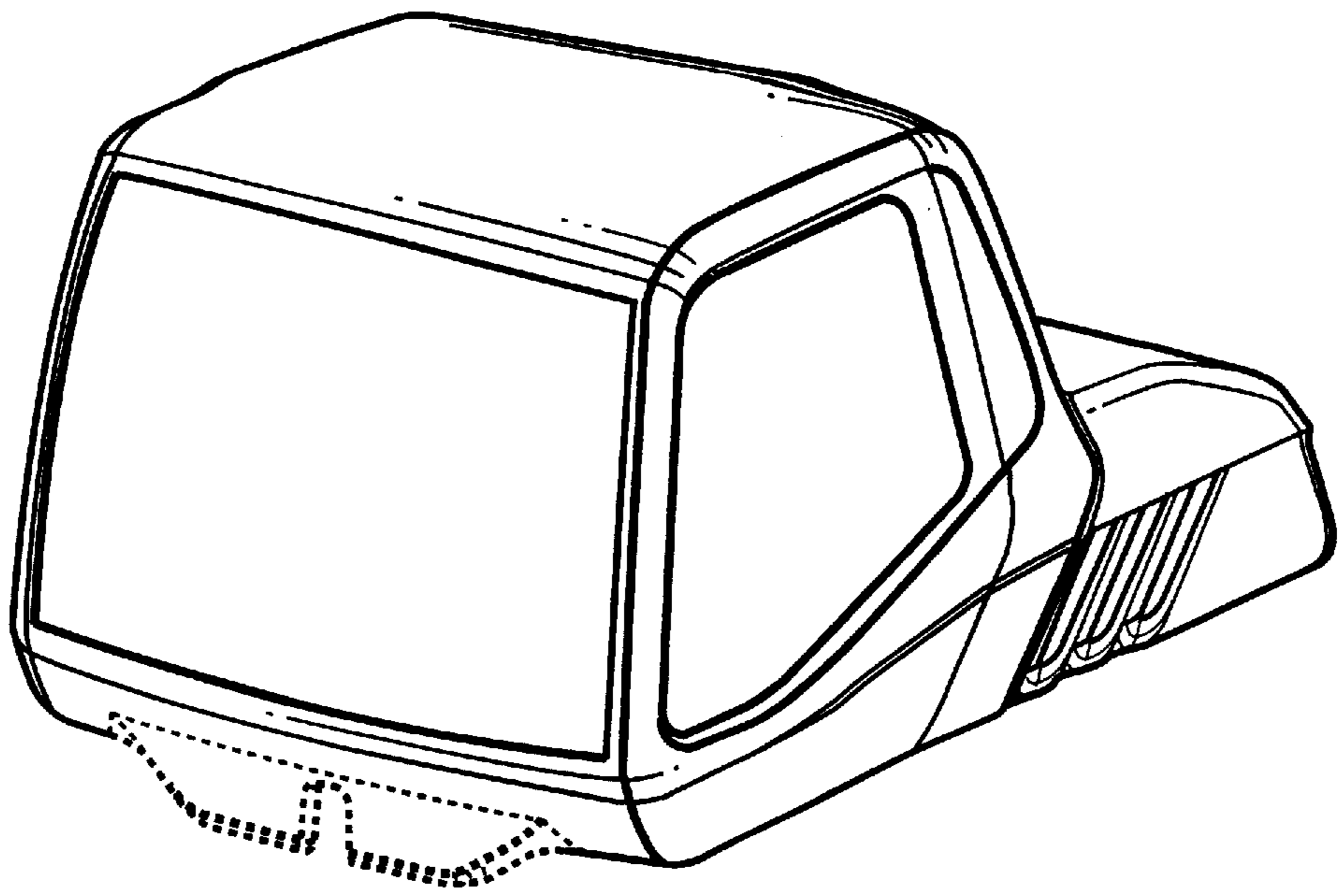

Fig.8

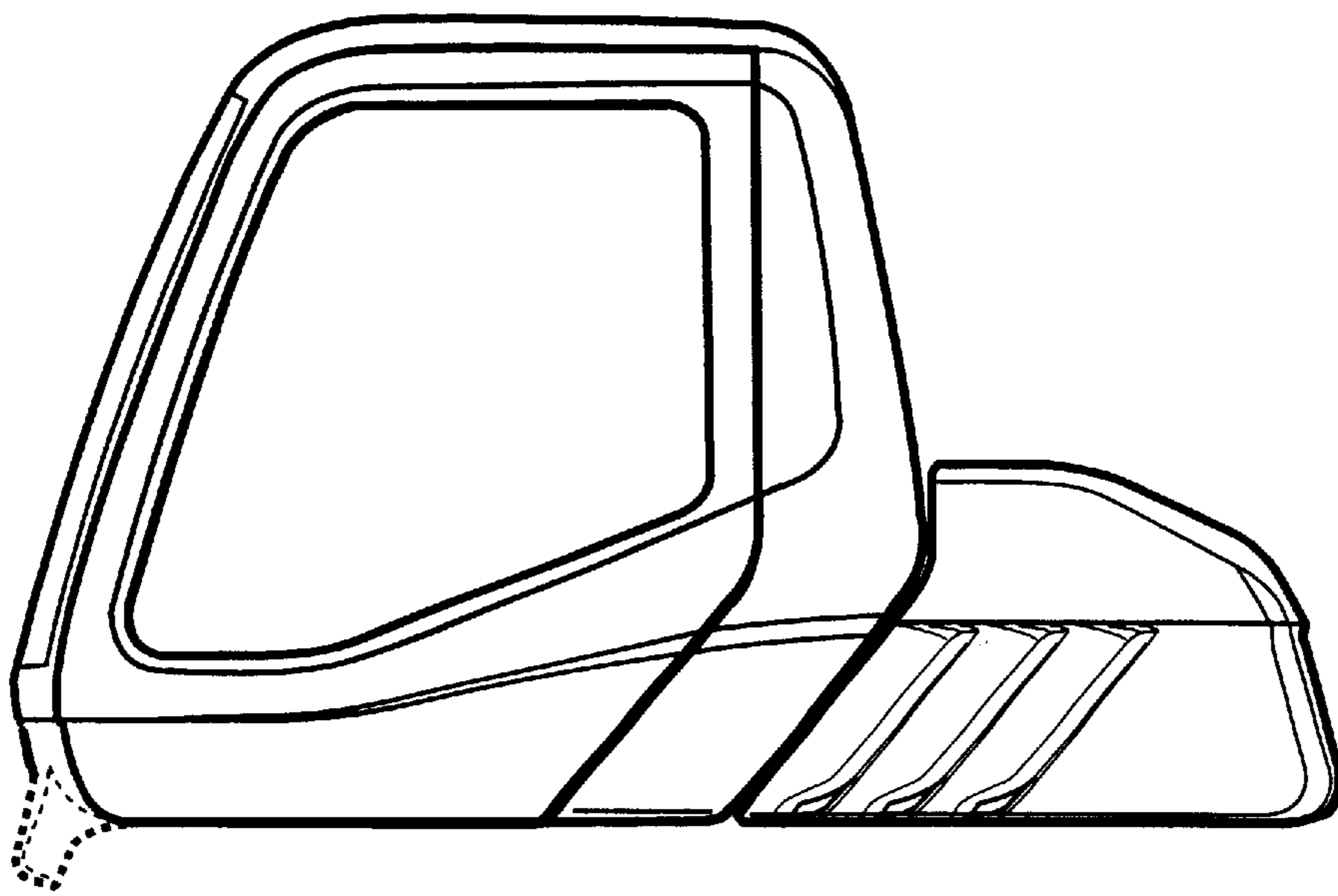

Fig.9

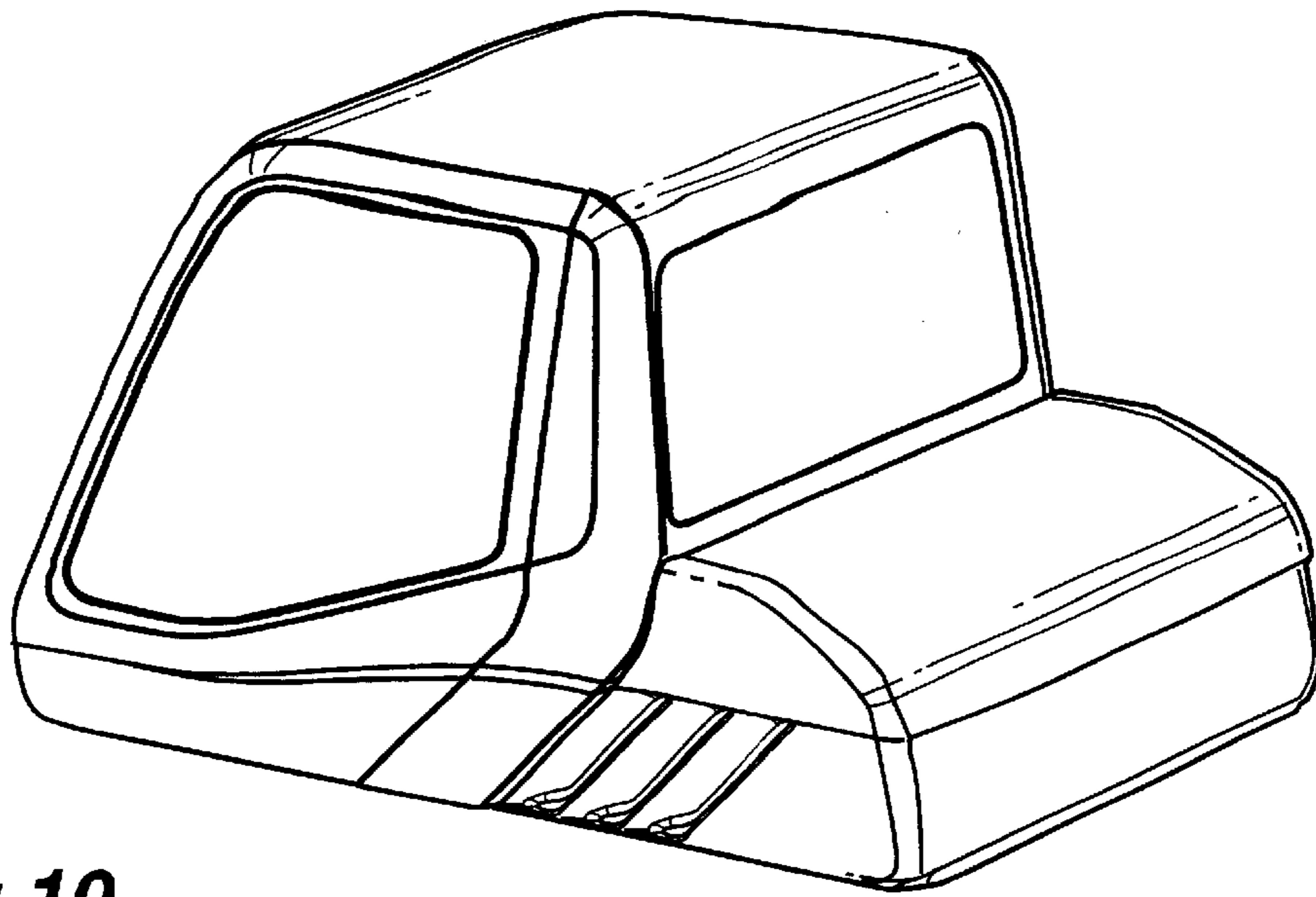

Fig.10

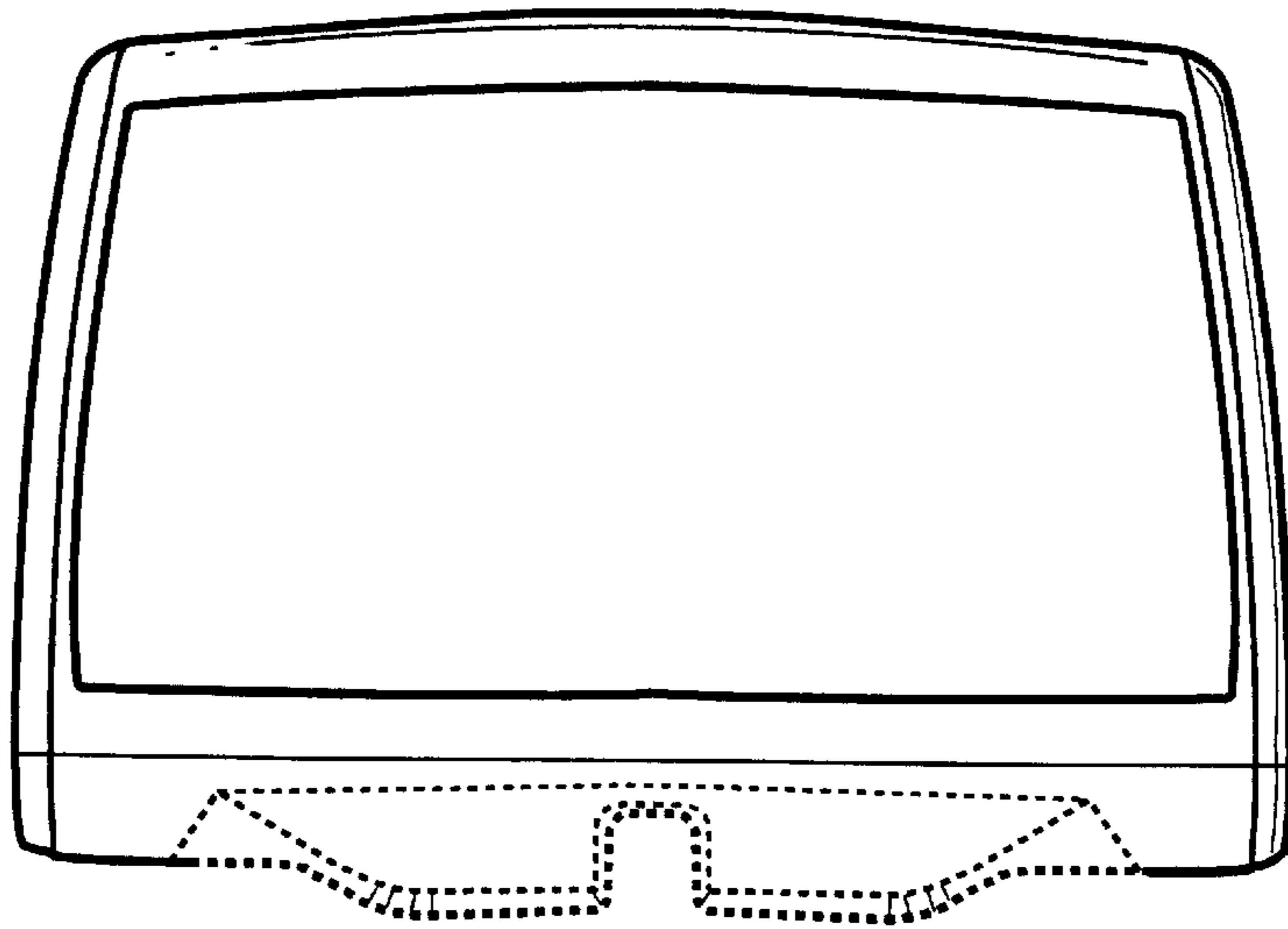

Fig.12

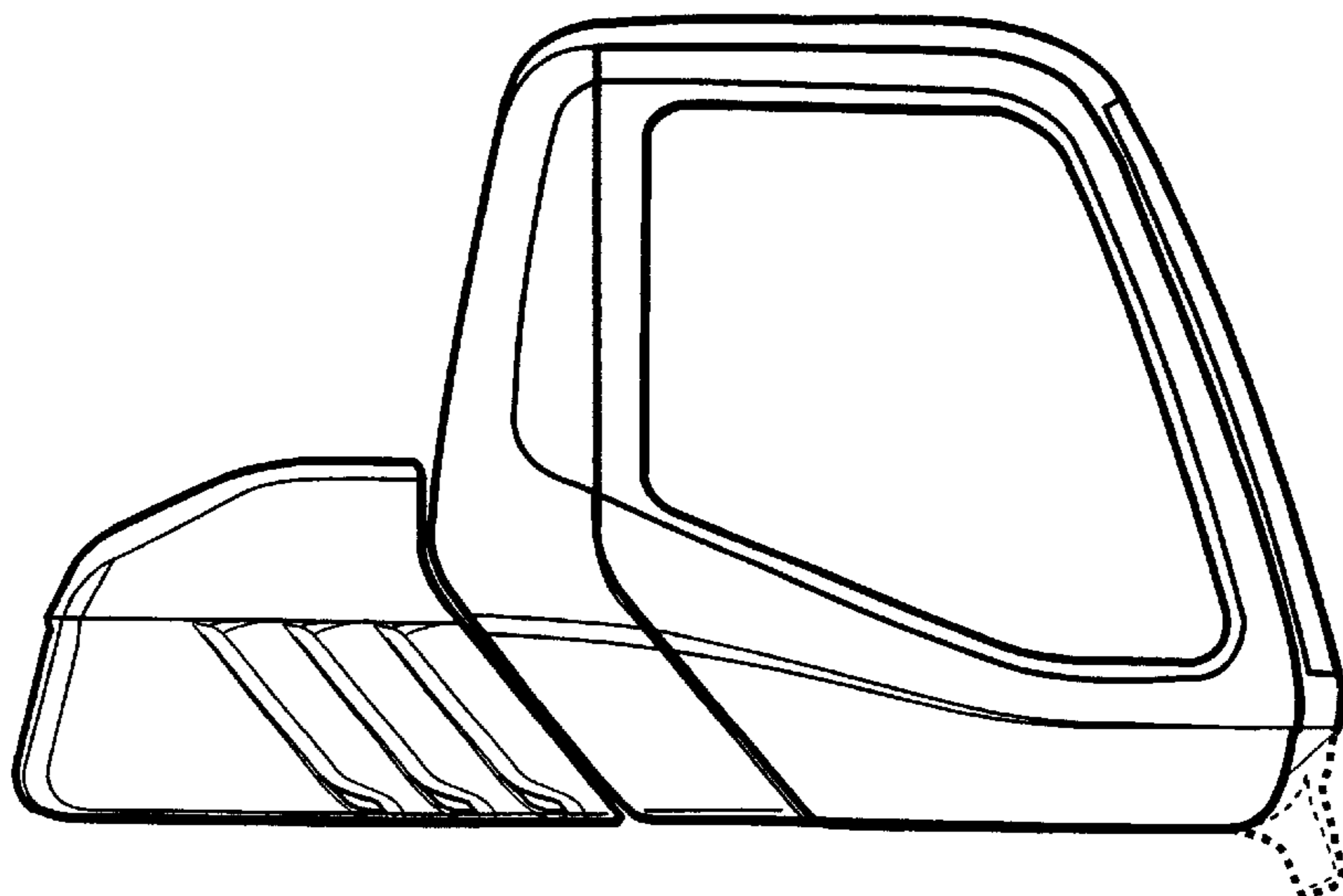

Fig.11

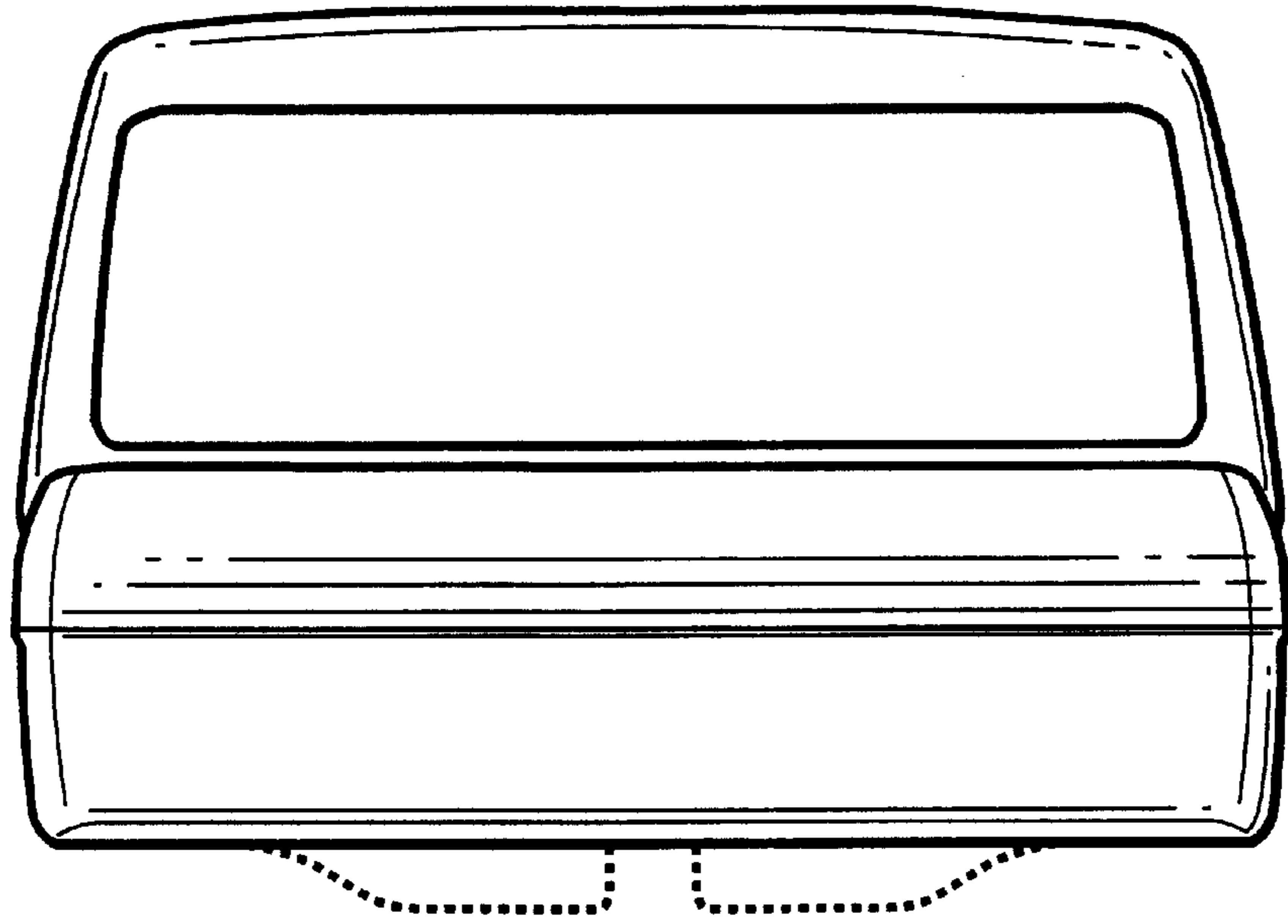

Fig.13

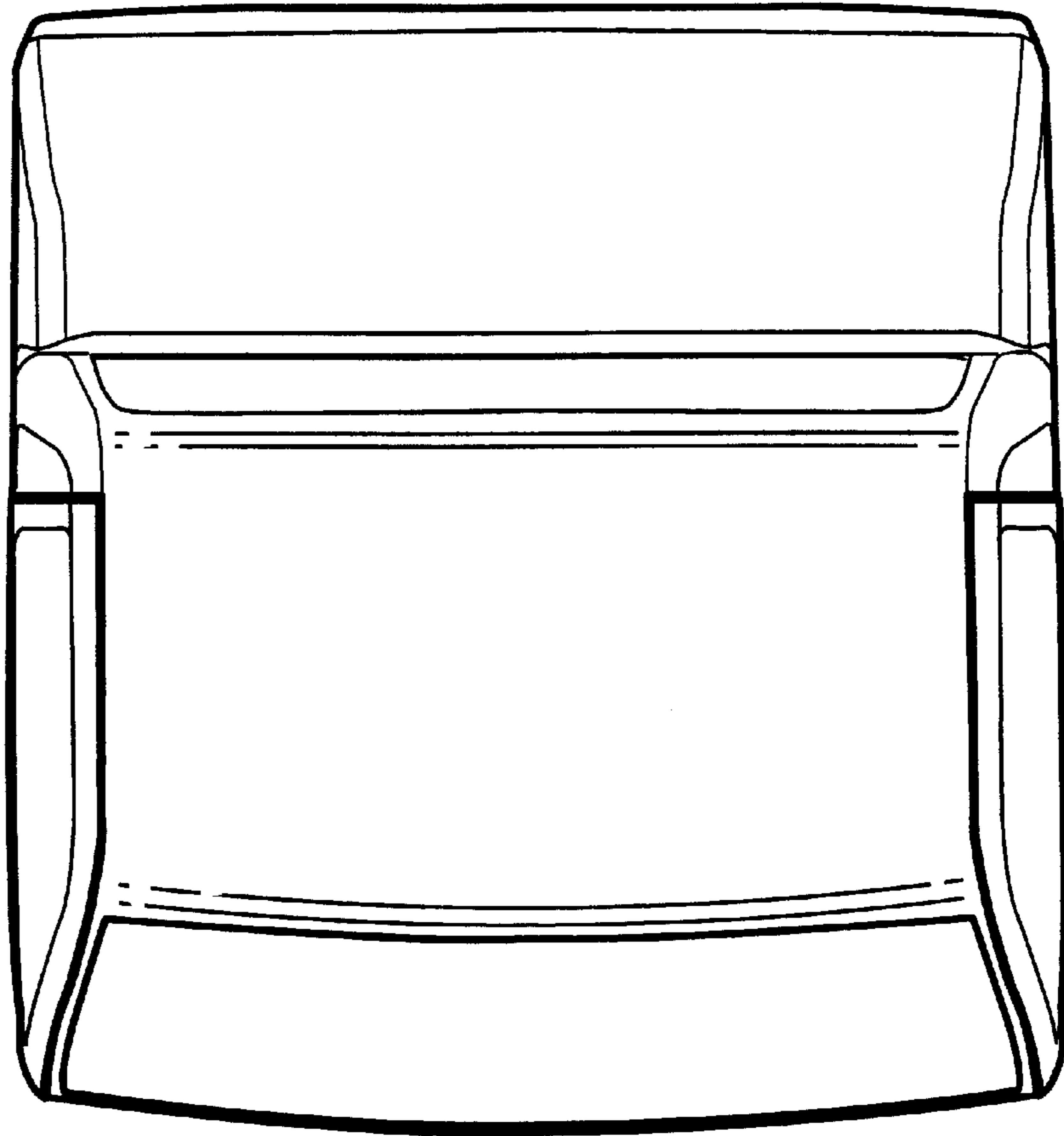

Fig.14

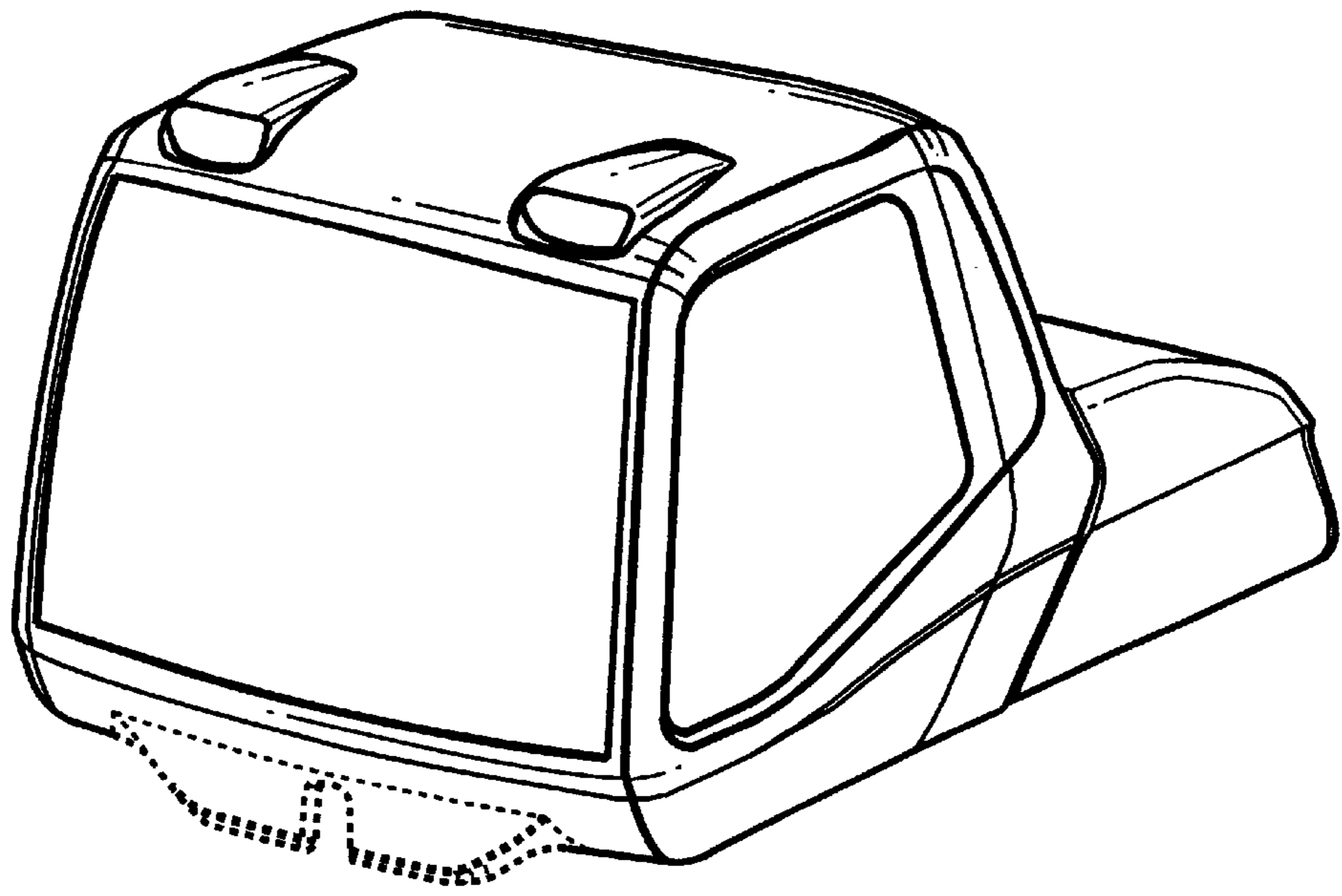

Fig.15

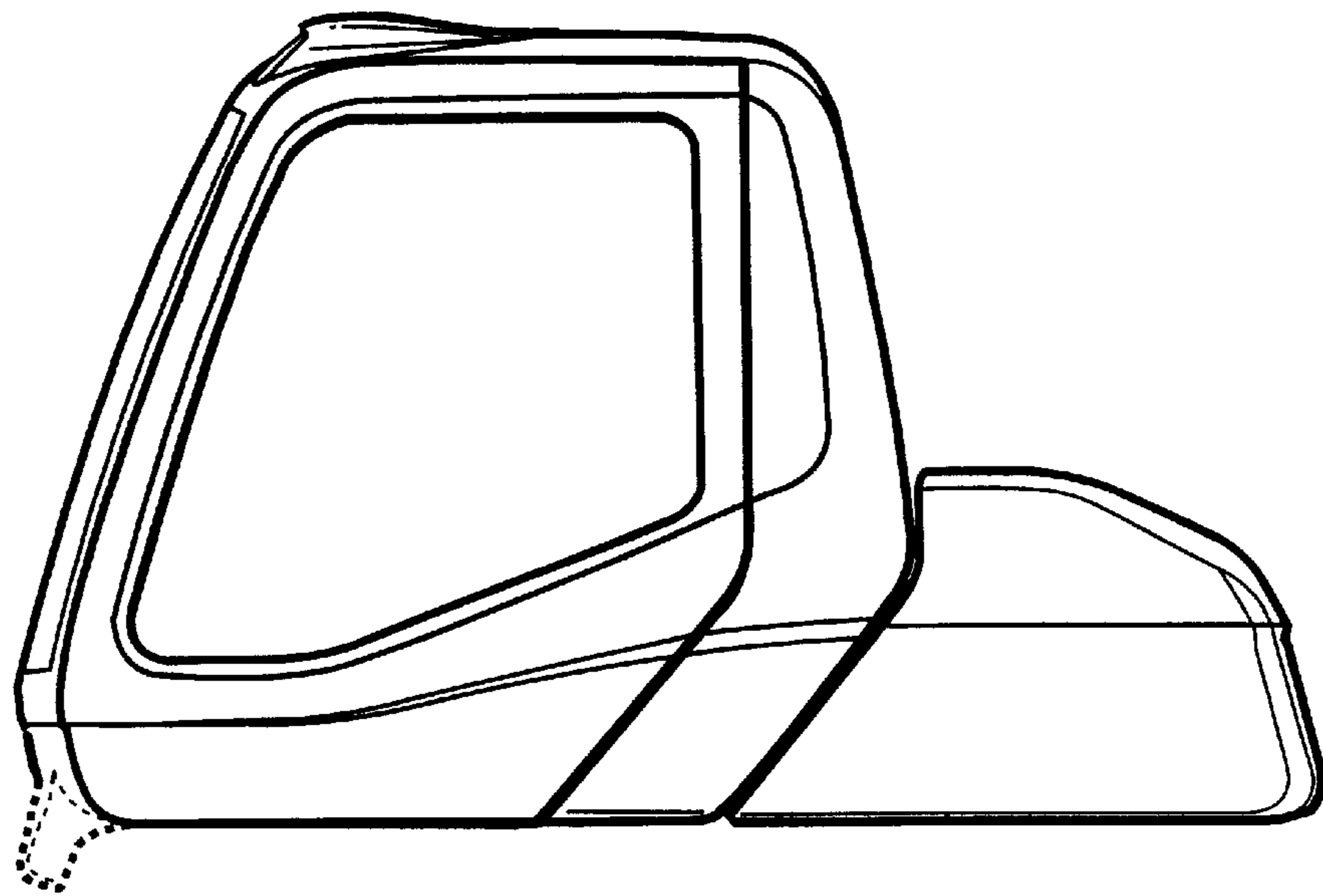

Fig.16

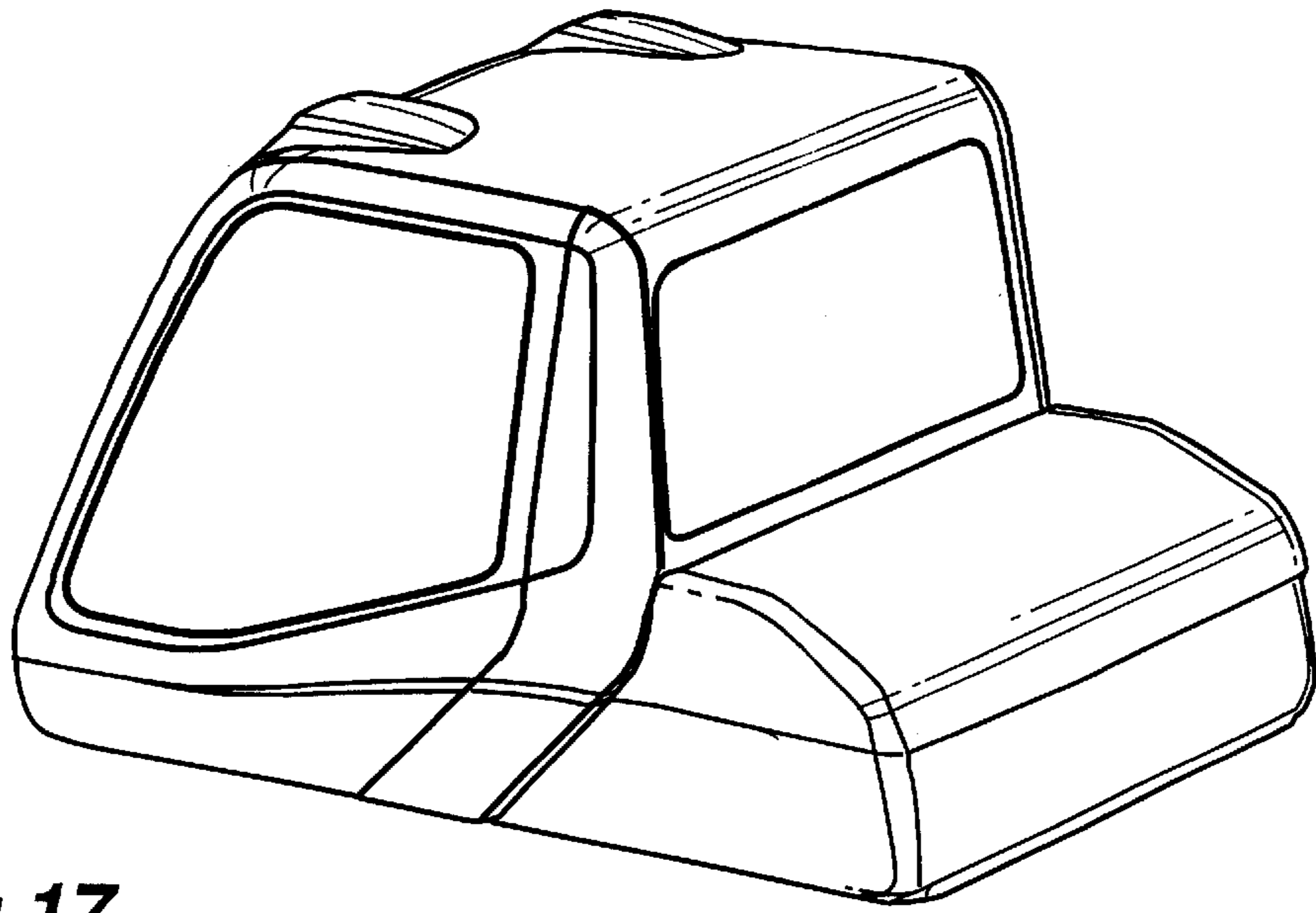

Fig. 17

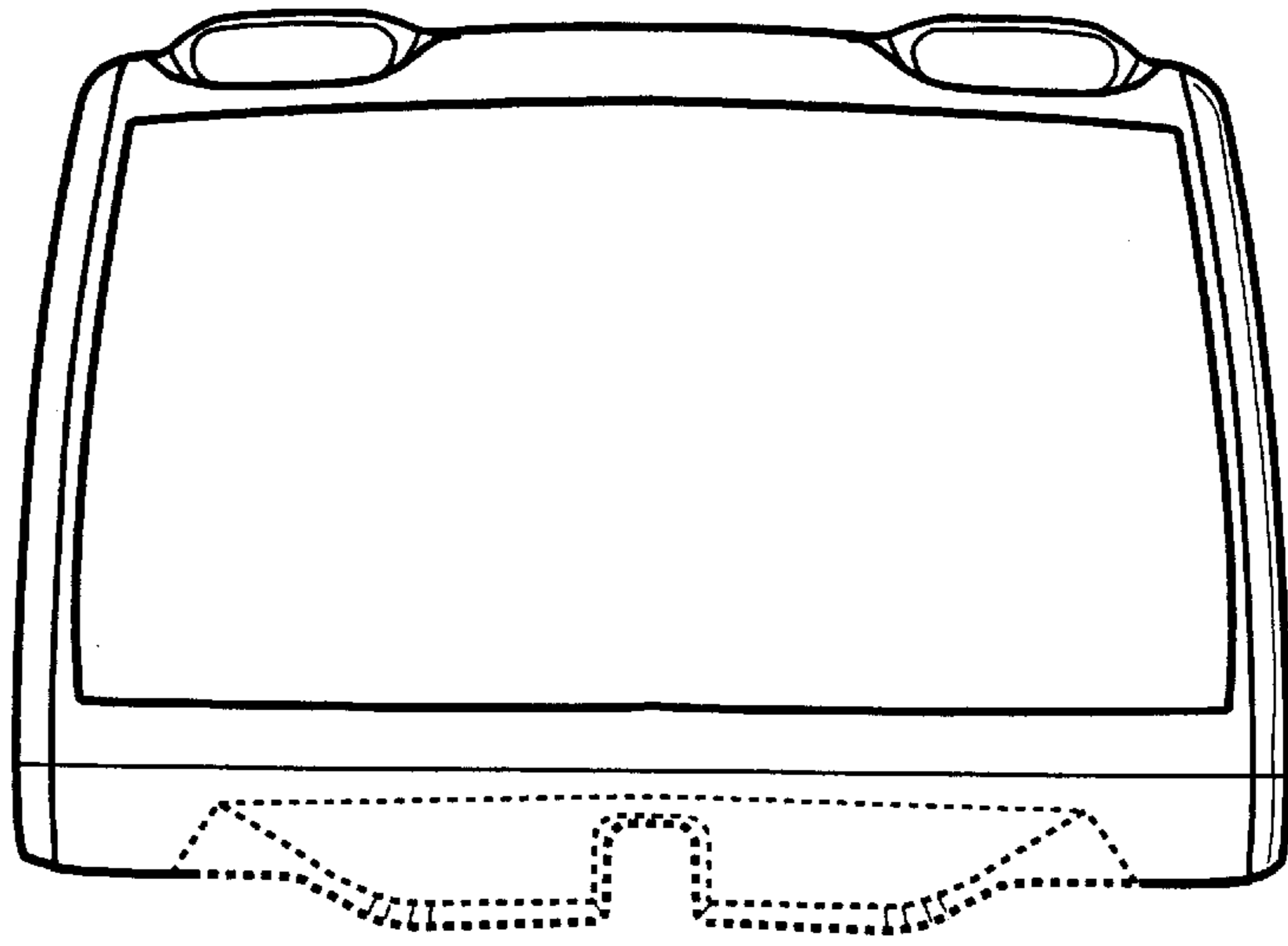

Fig. 19

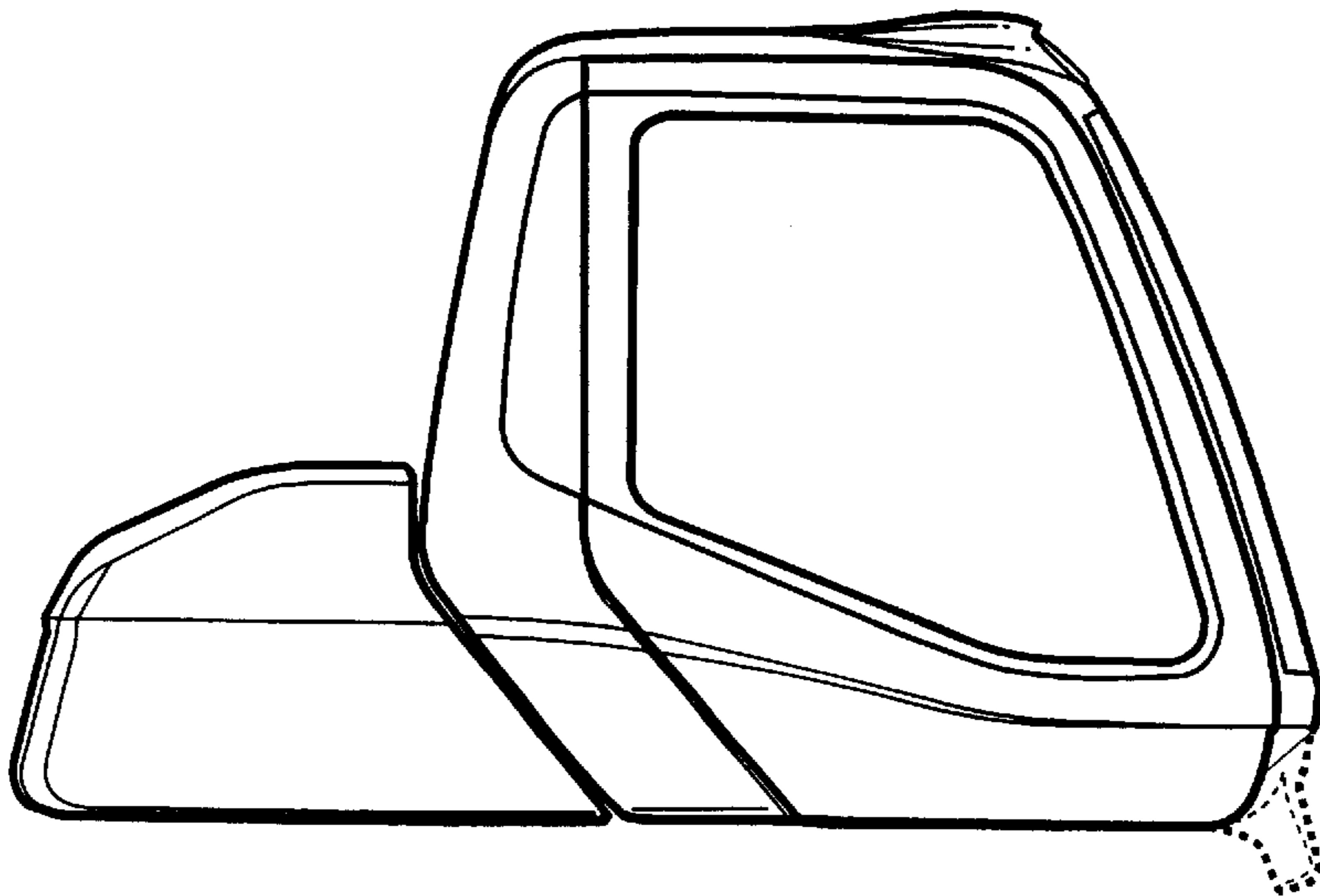

Fig. 18

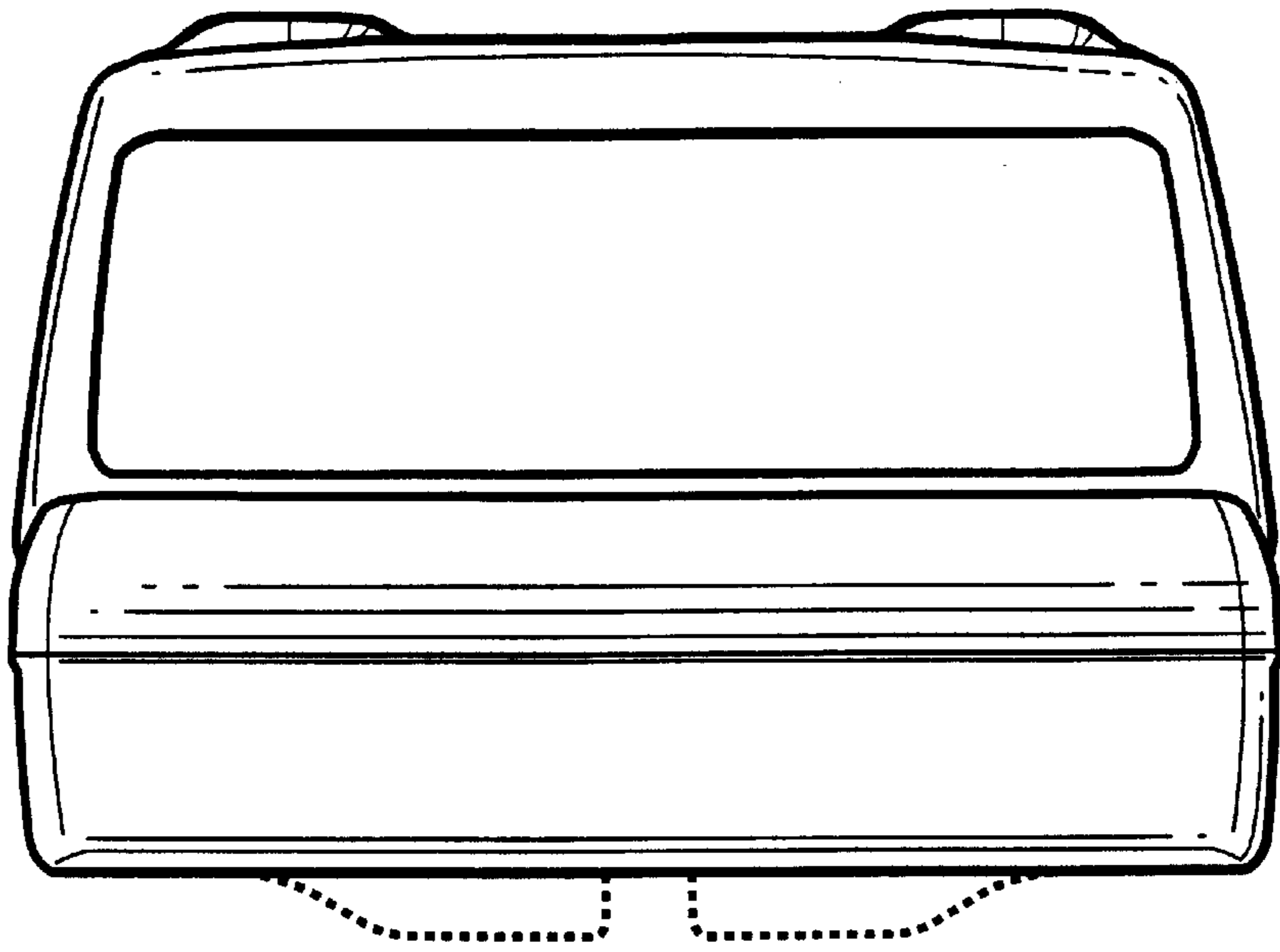

Fig.20

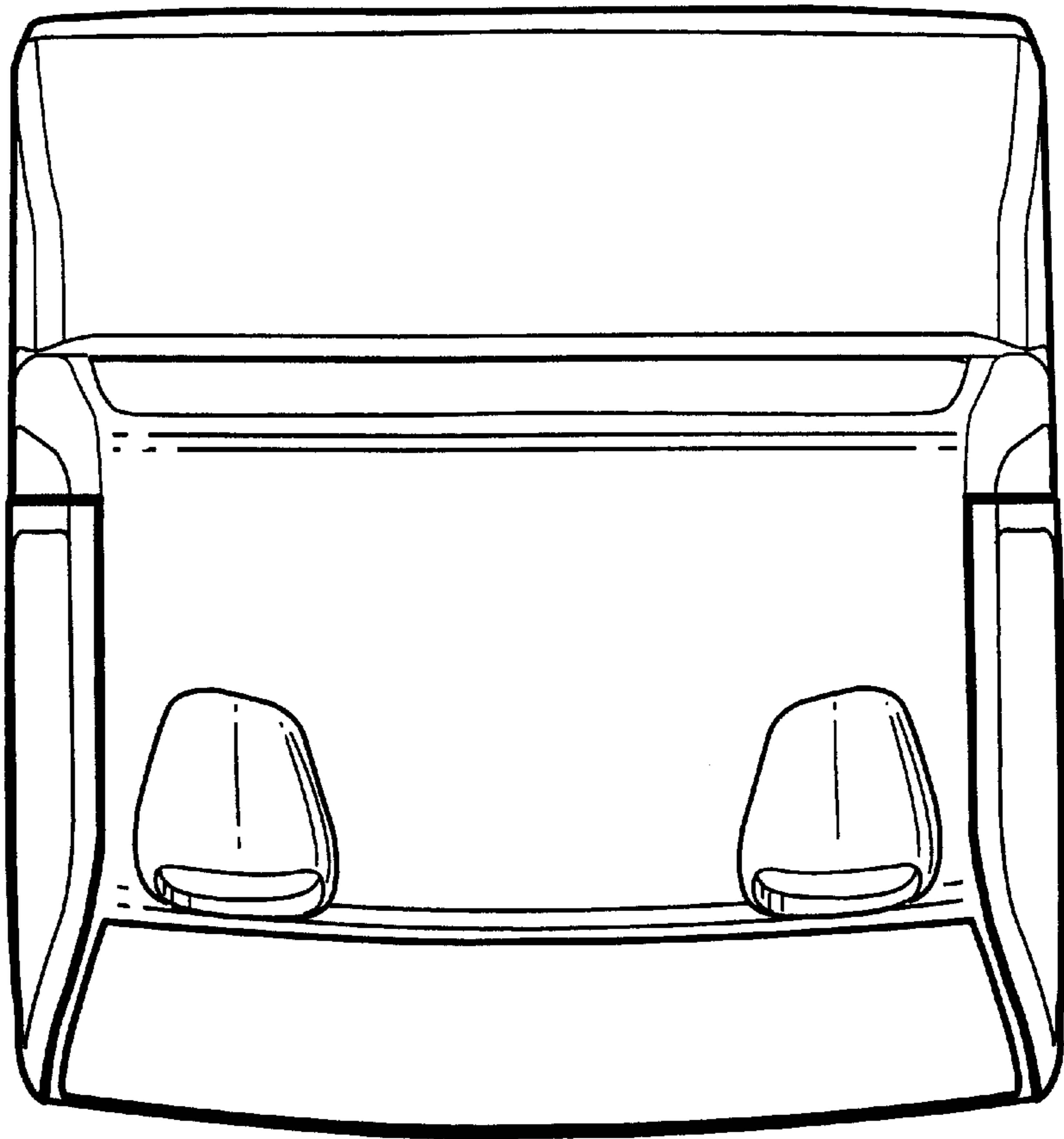

Fig.21