



US00D449145B1

(12) **United States Design Patent**
Wu

(10) **Patent No.:** **US D449,145 S**

(45) **Date of Patent:** **** Oct. 9, 2001**

(54) **GOLF CART HANDLEBAR**

5,897,129 * 4/1999 Wu 280/646

6,079,718 * 6/2000 Liao 280/47.26

6,126,184 * 10/2000 Liao 280/47.371

(76) Inventor: **David Wu**, No. 35-1, Jih Hsin Street,
Tu Cheng City, Taipei Hsien (TW)

* cited by examiner

(**) Term: **14 Years**

Primary Examiner—Kay H. Chin

(74) *Attorney, Agent, or Firm*—Varndell & Varndell, PLLC

(21) Appl. No.: **29/133,248**

(22) Filed: **Nov. 28, 2000**

(57) **CLAIM**

The ornamental design for a golf cart handlebar, as shown and described.

(51) **LOC (7) Cl.** **12-02**

(52) **U.S. Cl.** **D34/27**

(58) **Field of Search** D34/12-27; D8/10,
D8/DIG. 6; D12/178; 74/551.6, 551.3,
551.9; 294/57; 16/426, 422, 430; 280/DIG. 5,
DIG. 6

DESCRIPTION

FIG. 1 is a perspective view of a golf cart handlebar showing my new design;

FIG. 2 is a front elevational view thereof;

FIG. 3 is a rear elevational view thereof;

FIG. 4 is a top plan view thereof;

FIG. 5 is a right side elevational view thereof; and,

FIG. 6 is a left side elevational view thereof, the opposite side being a mirror image of that shown.

(56) **References Cited**

U.S. PATENT DOCUMENTS

D. 331,652 * 12/1992 Wu D34/27

D. 353,700 * 12/1994 Wu D34/27

D. 392,083 * 3/1998 Wu D34/27

5,873,147 * 2/1999 Hintz 16/426

1 Claim, 6 Drawing Sheets

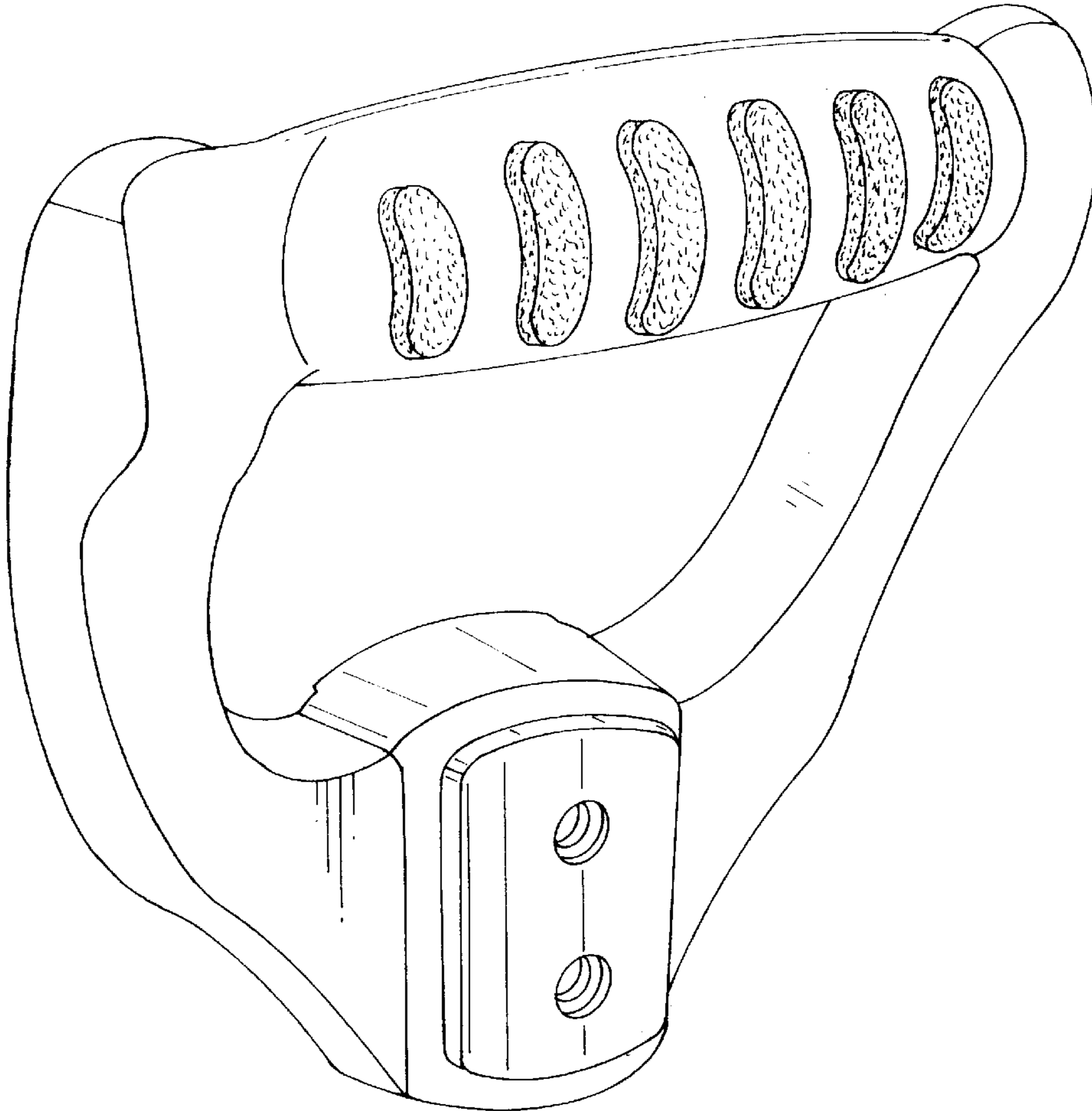

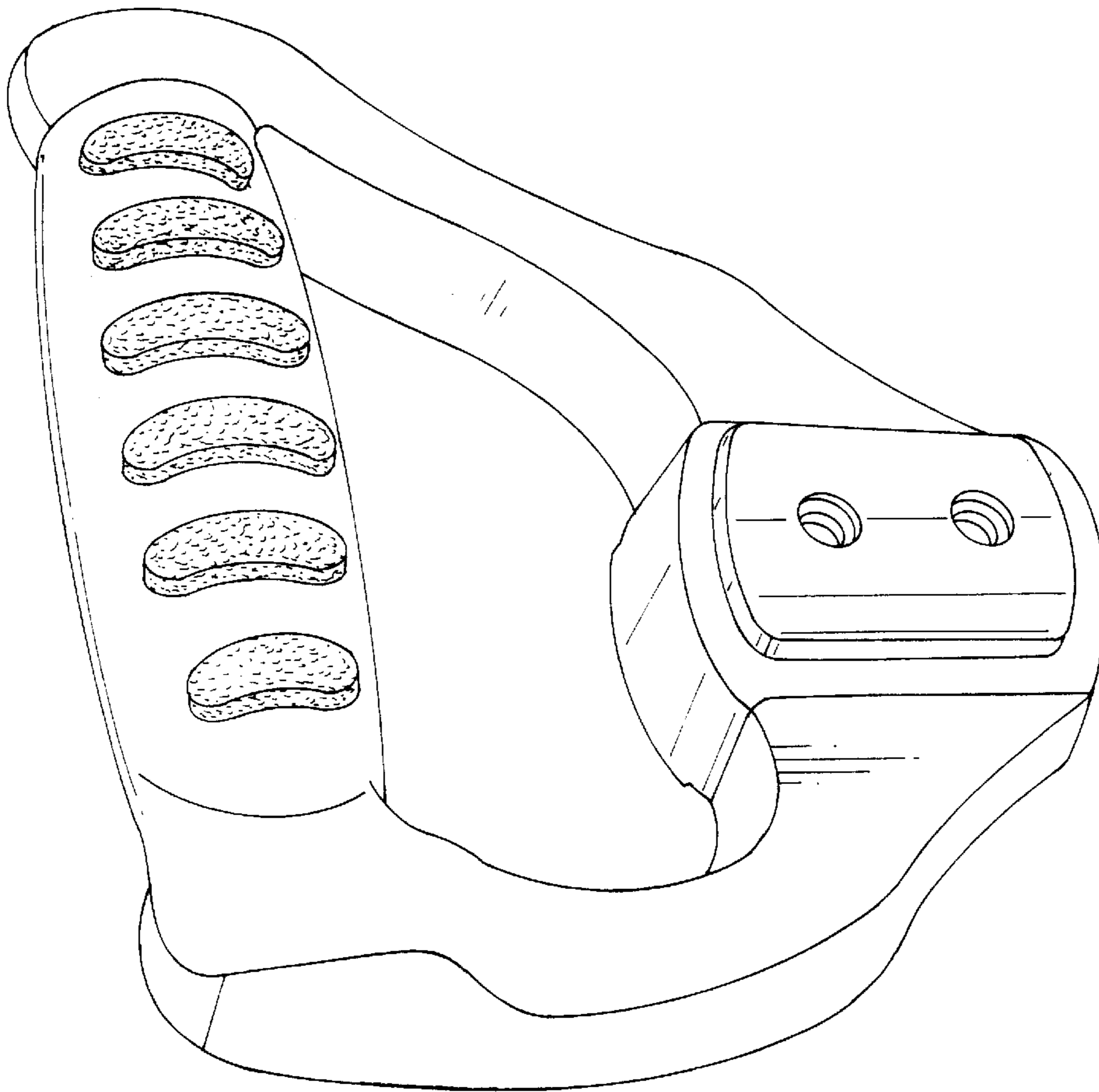

Fig. 1

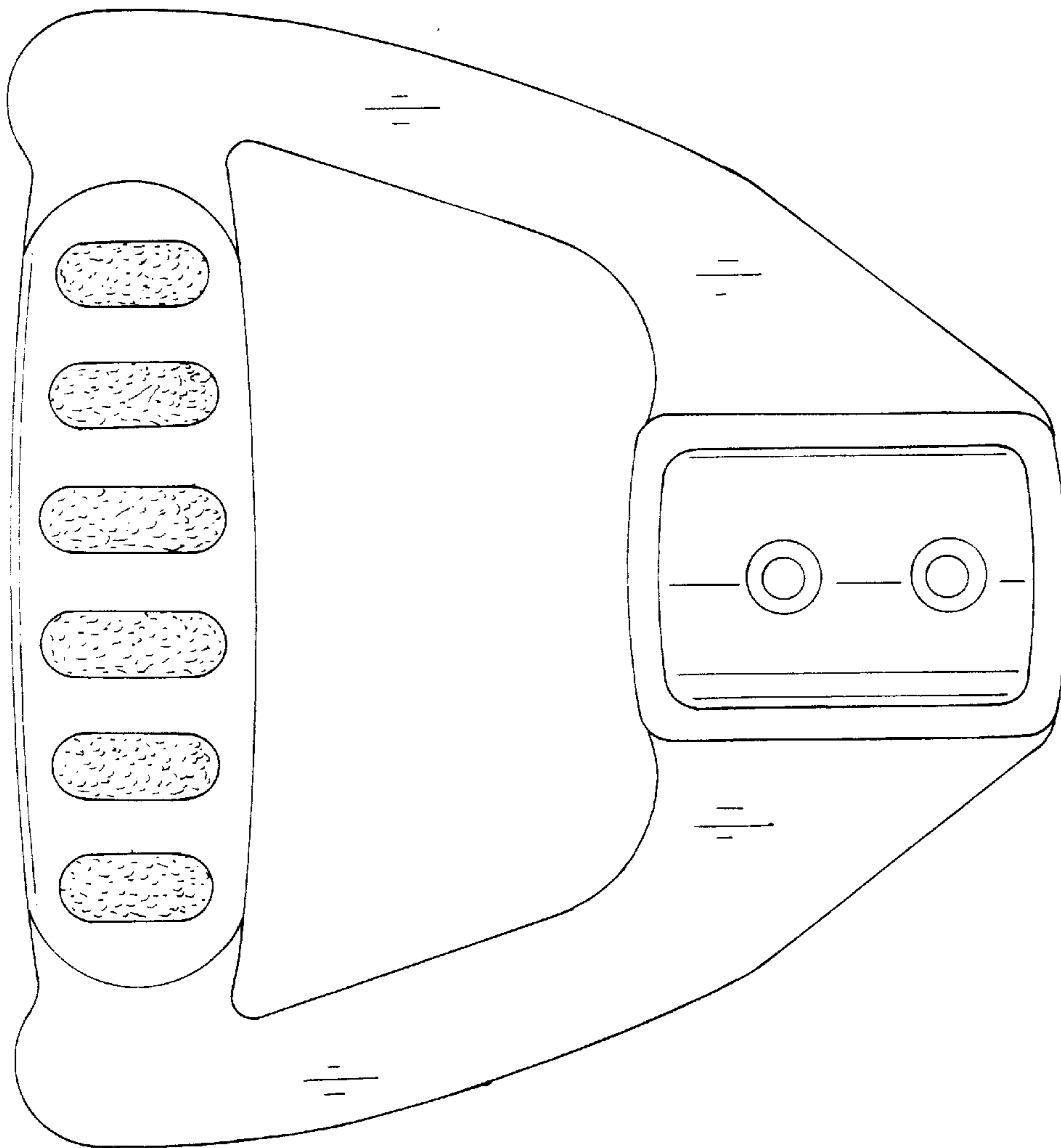

Fig. 2

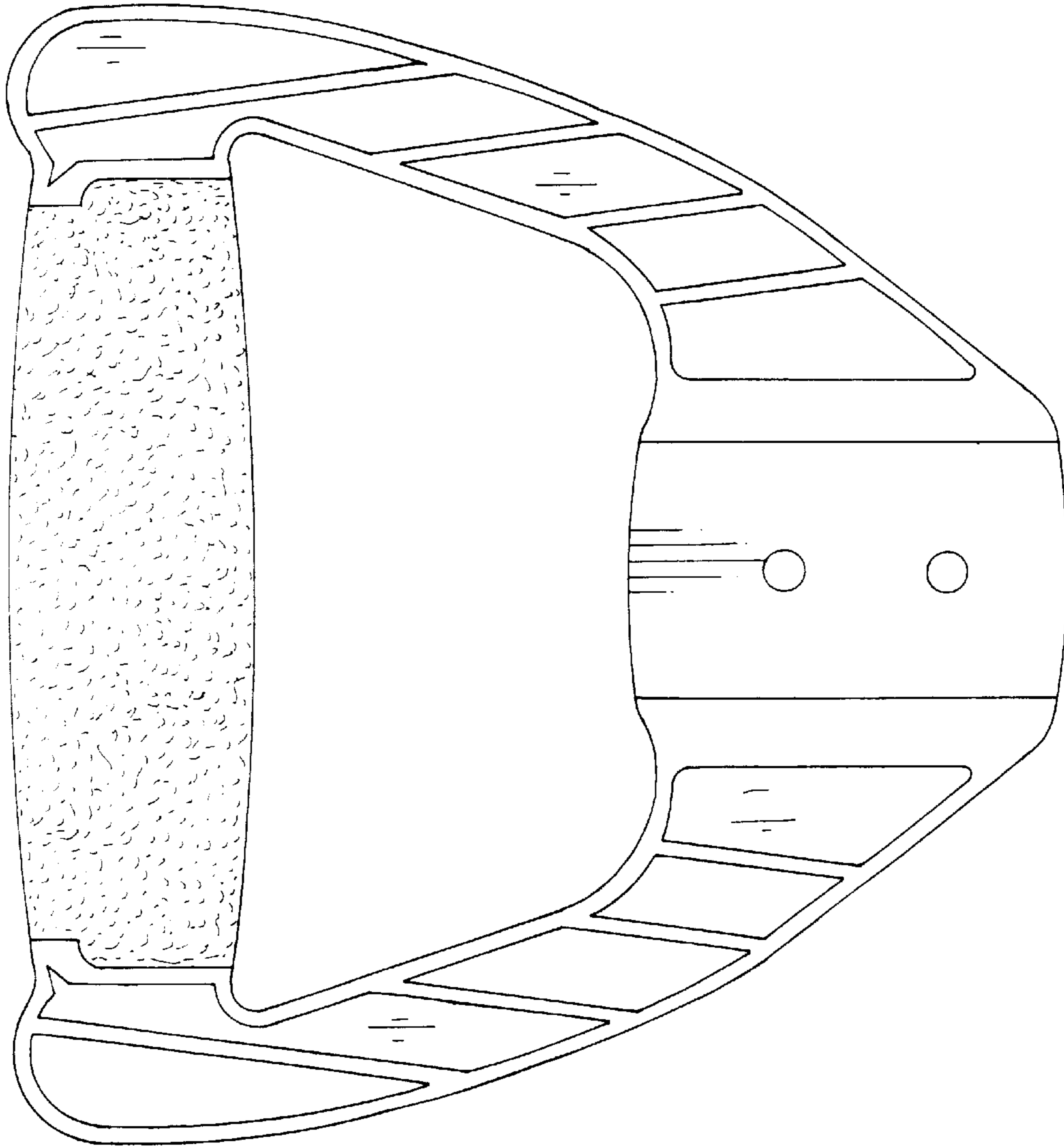

Fig. 3

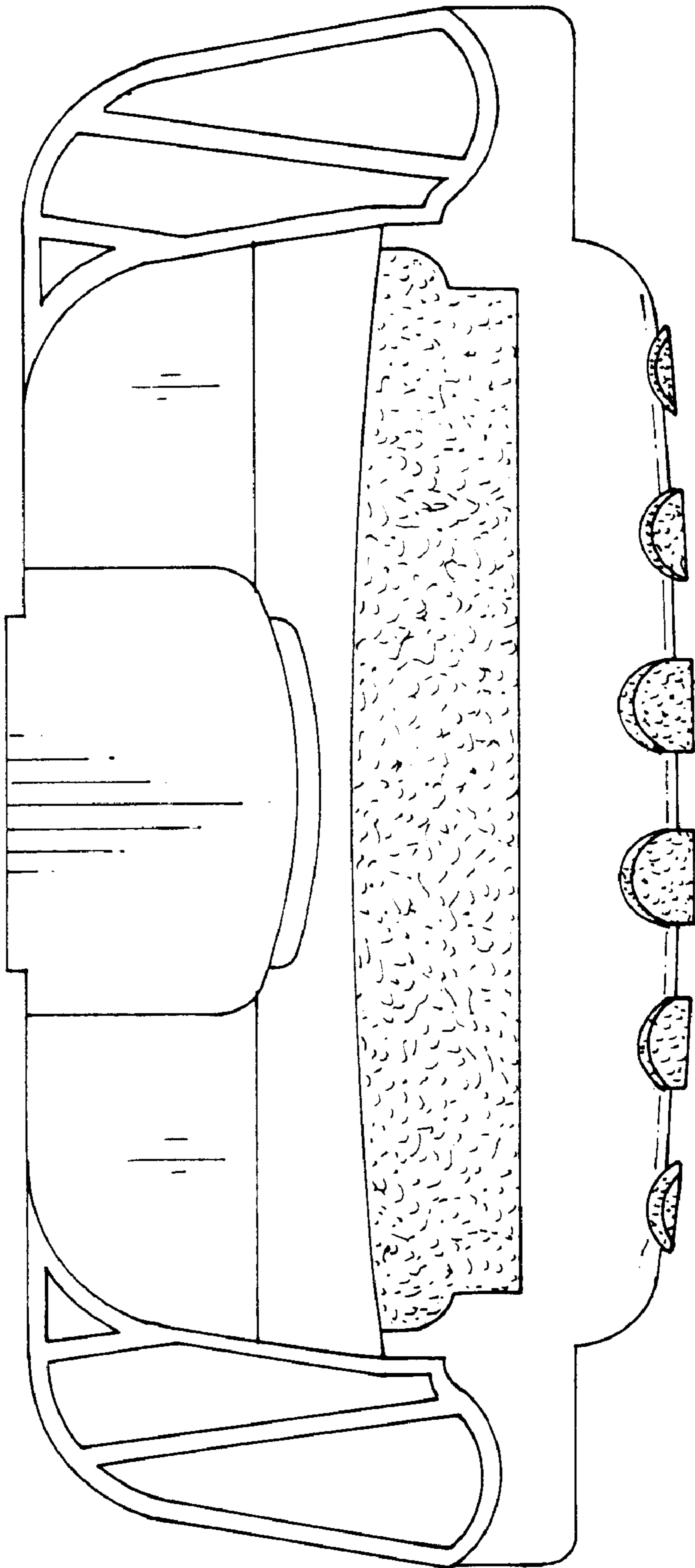

Fig. 4

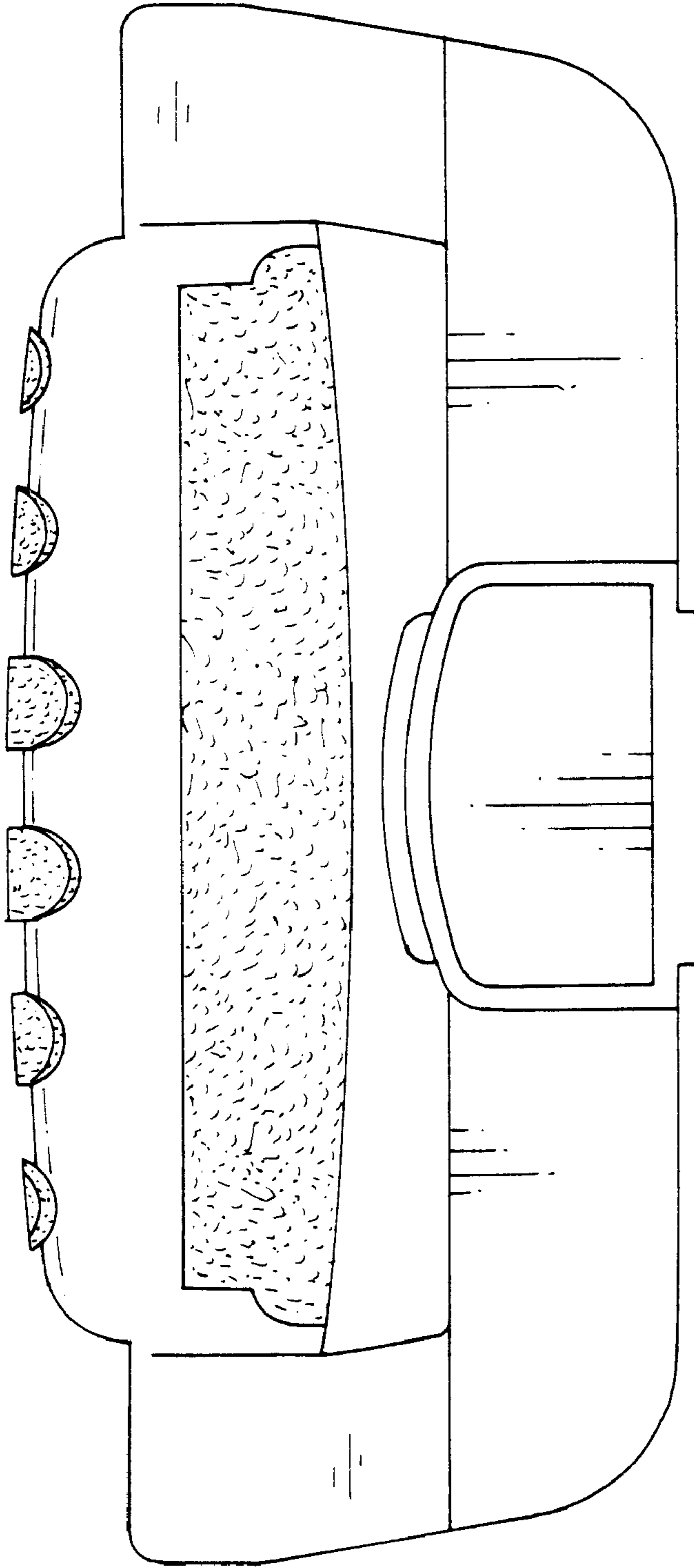

Fig. 5

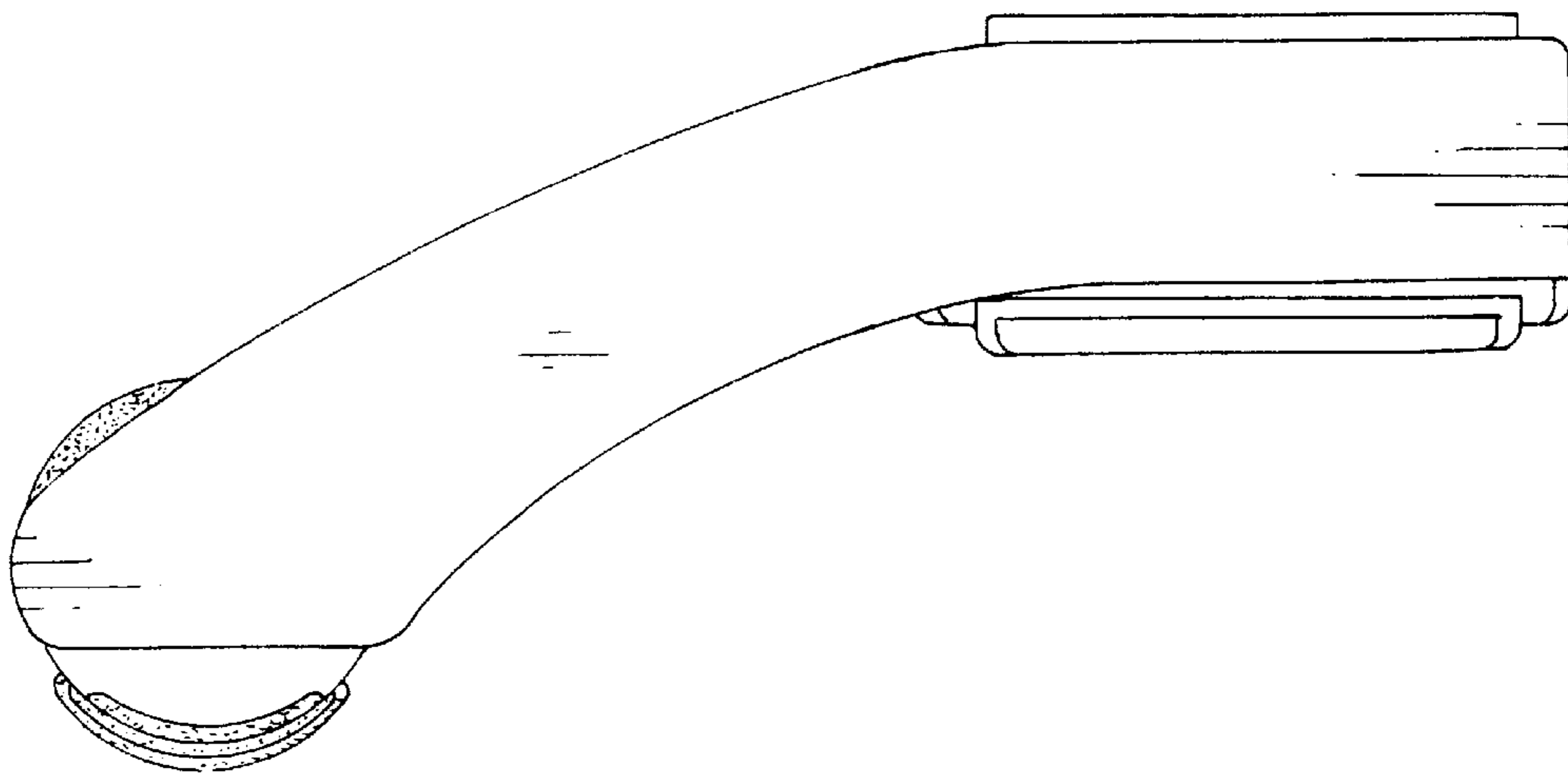

Fig. 6