



US00D448433B1

(12) **United States Design Patent**
Ueda et al.

(10) **Patent No.:**

US D448,433 S

(45) **Date of Patent:**

**** Sep. 25, 2001**

(54) **ROBOTIC DOG**

(75) Inventors: **Mie Ueda; Tomohiko Onishi; Nobata Fujio**, all of Tokyo (JP)

(73) Assignee: **Sega Toys Ltd.**, Tokyo (JP)

(**) Term: **14 Years**

(21) Appl. No.: **29/122,730**

(22) Filed: **May 1, 2000**

Related U.S. Application Data

(63) Continuation-in-part of application No. 29/122,078, filed on Apr. 19, 2000.

(30) **Foreign Application Priority Data**

Nov. 2, 1999 (JP) 11-30240

(51) **LOC (7) Cl.** **21-01**

(52) **U.S. Cl.** **D21/578; D21/611**

(58) **Field of Search** D21/576, 578,
D21/584, 585, 611-613; 446/97, 268, 317;
318/568.12

(56) **References Cited**

U.S. PATENT DOCUMENTS

- D. 178,513 * 8/1956 Glass D21/611
- D. 186,323 * 10/1959 Kinniburgh D21/611
- D. 373,801 * 9/1996 Doi et al. D21/611
- D. 418,551 * 1/2000 Kageyama et al. D21/611
- D. 421,634 * 3/2000 Kageyama et al. D21/584
- D. 424,625 * 5/2000 Yamazaki D21/611
- D. 431,270 * 9/2000 Kawakita et al. D21/611
- 5,713,780 * 2/1998 Gallagher 446/364
- 5,870,527 2/1999 Fujikawa et al. 395/80
- 5,929,585 7/1999 Fujita 318/568.2
- 5,963,712 10/1999 Fujita et al. 395/99

FOREIGN PATENT DOCUMENTS

0 898 237 A2 2/1999 (EP) .

- 0 923 011 A2 6/1999 (EP) .
- 0 924 034 A2 6/1999 (EP) .
- 1050592 6/1999 (JP) .
- 0138550 9/1999 (JP) .
- 1050592-1 9/1999 (JP) .
- WO 99/64208 12/1999 (WO) .
- WO 99/67067 12/1999 (WO) .

* cited by examiner

Primary Examiner—Sandra L. Morris

(74) *Attorney, Agent, or Firm*—Fitch, Even, Tabin & Flannery

(57)

CLAIM

The ornamental design for a robotic dog, as shown and described.

DESCRIPTION

FIG. 1 is a front view showing a first embodiment of our new design;

FIG. 2 is a rear view thereof;

FIG. 3 is a top plan view thereof;

FIG. 4 is a bottom plan view thereof;

FIG. 5 is a side view thereof, the opposite side being a mirror image thereof;

FIG. 6 is a perspective view of a second embodiment of our new design;

FIG. 7 is a side view thereof, the opposite side being a mirror image thereof;

FIG. 8 is a front view thereof;

FIG. 9 is a rear view thereof;

FIG. 10 is a top plan view thereof;

FIG. 11 is a bottom plan view thereof; and,

FIG. 12 is a side view thereof, the broken lines depicting the robotic dog in a sitting position, the solid lines depicting the robotic dog in a standing position, the opposite side being a mirror image thereof.

1 Claim, 7 Drawing Sheets

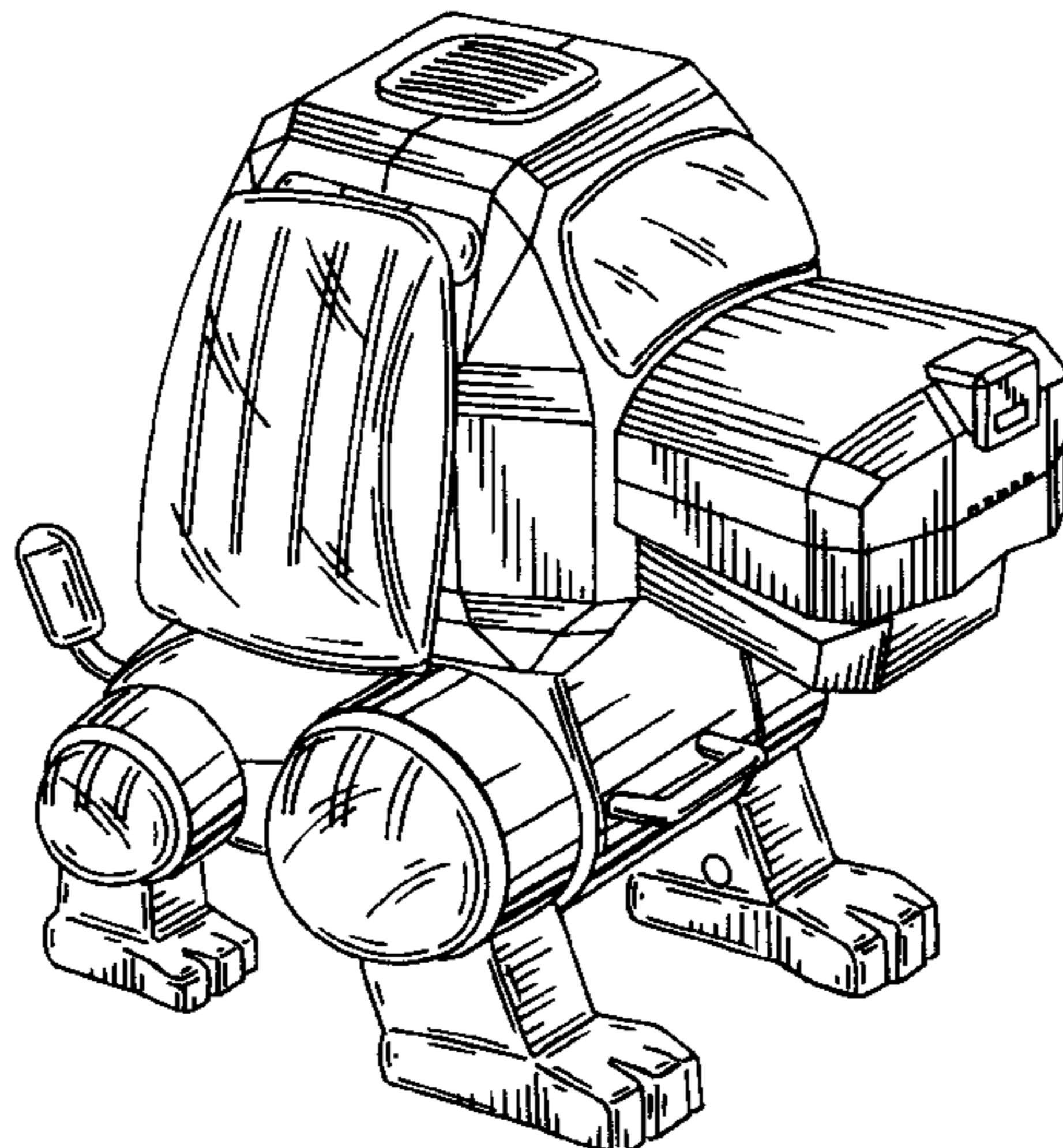

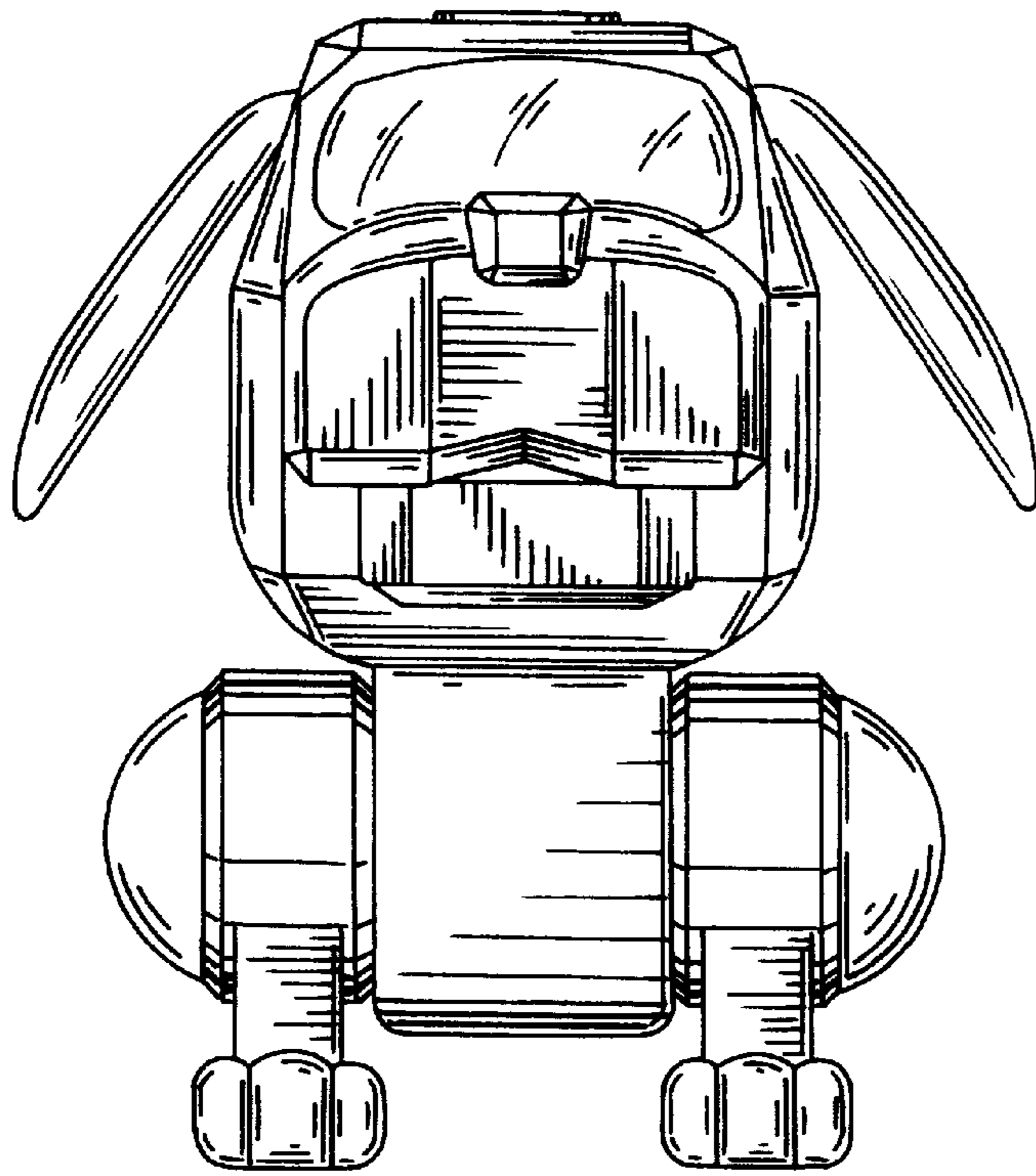

FIG. 1

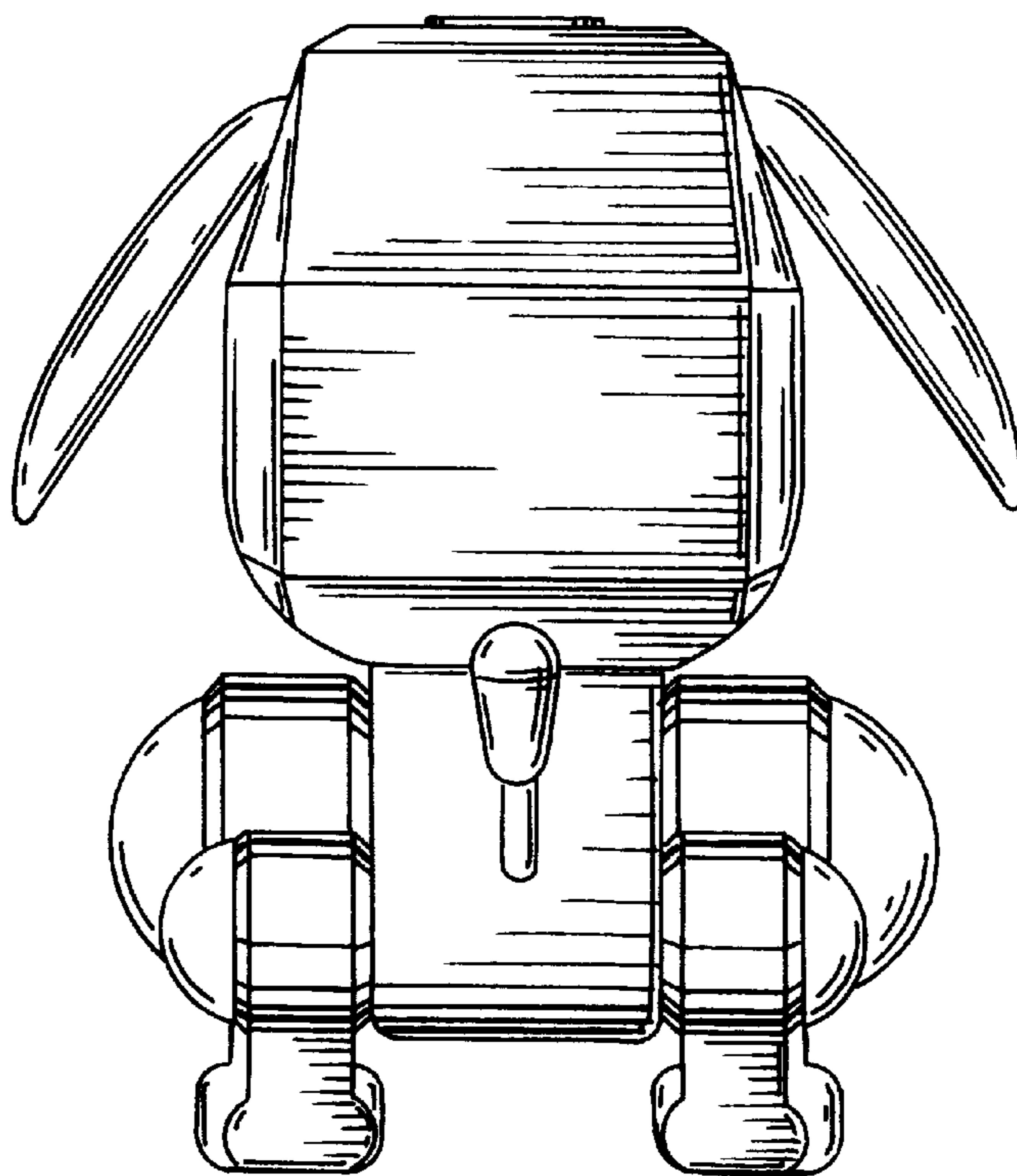

FIG. 2

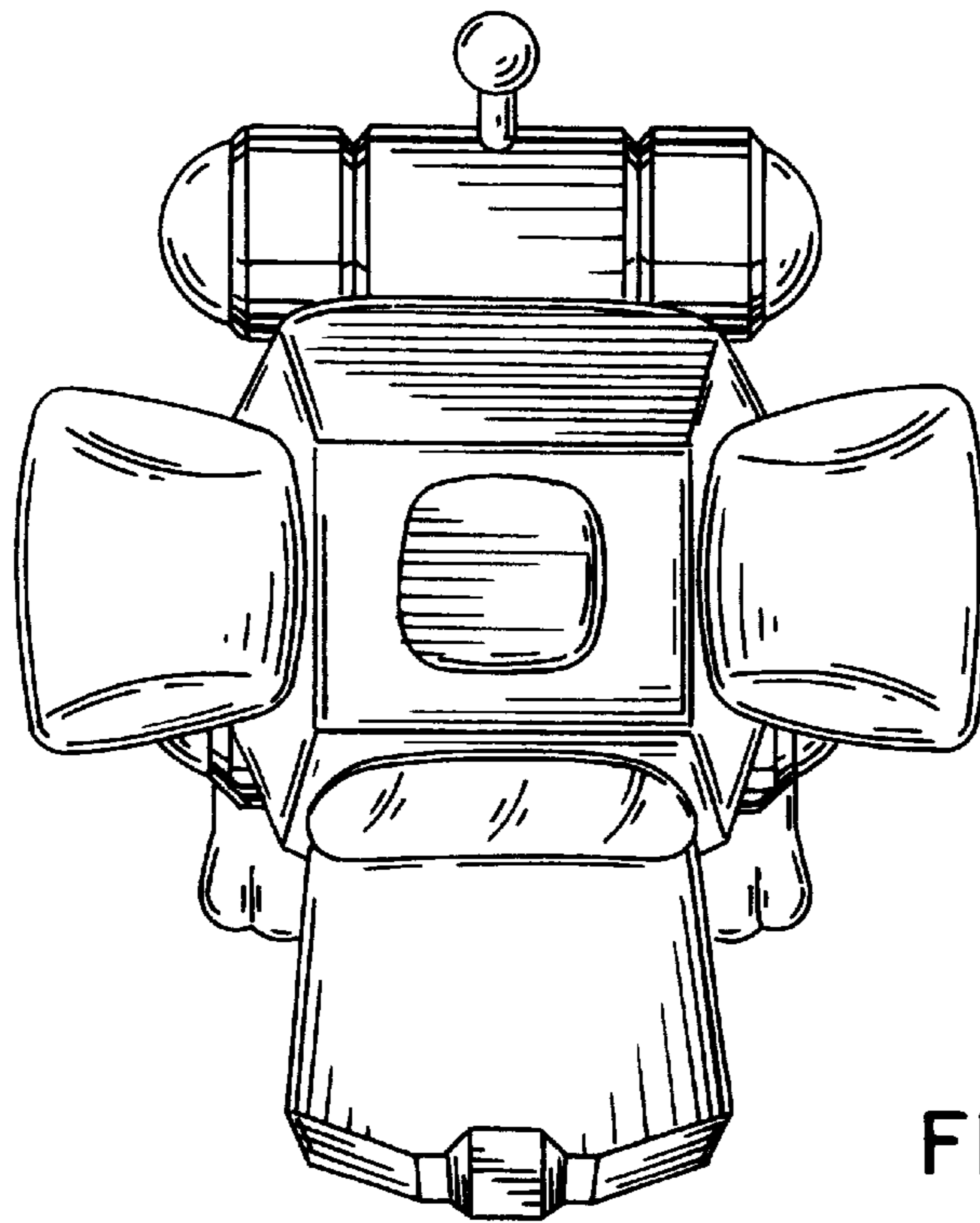

FIG. 3

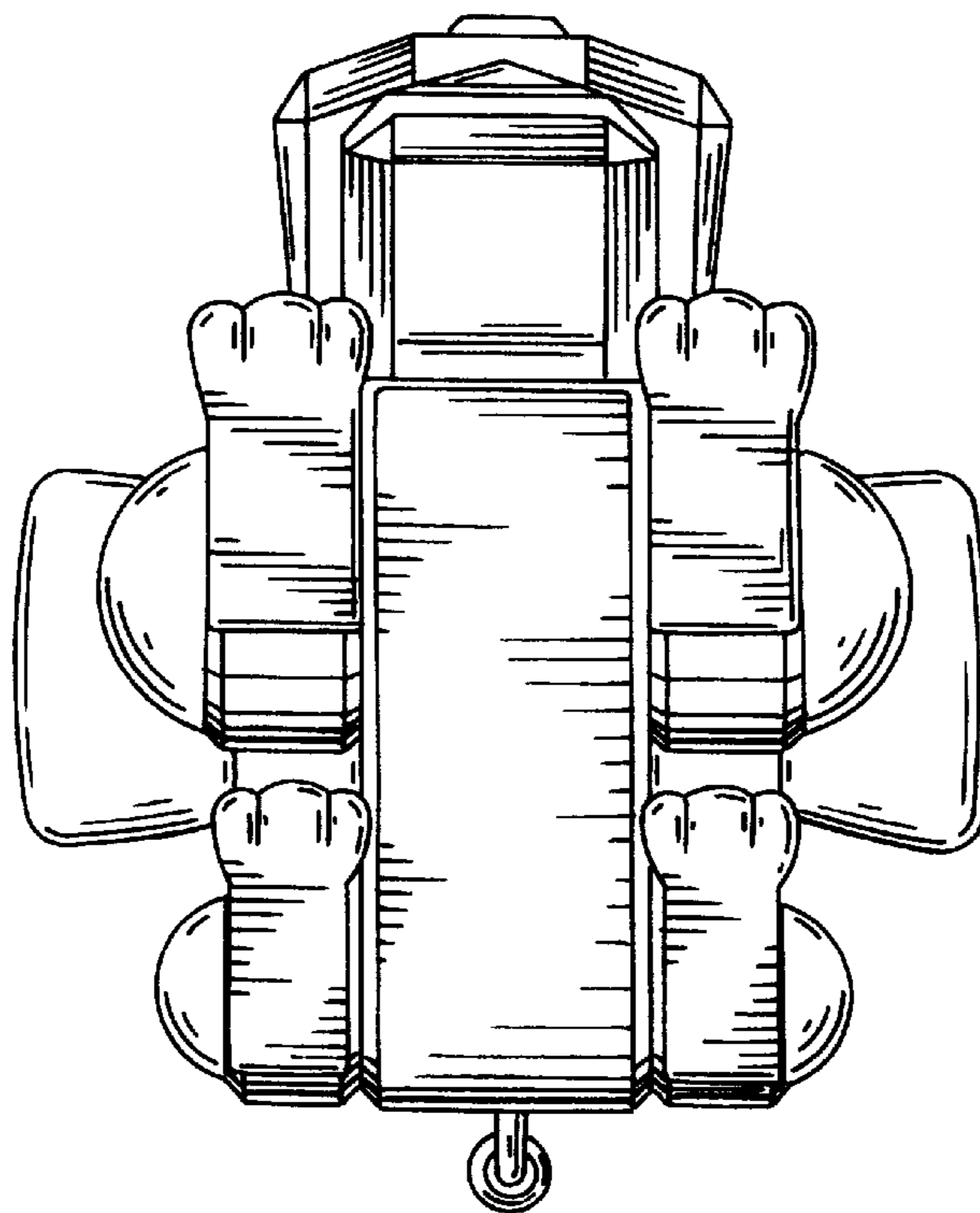

FIG. 4

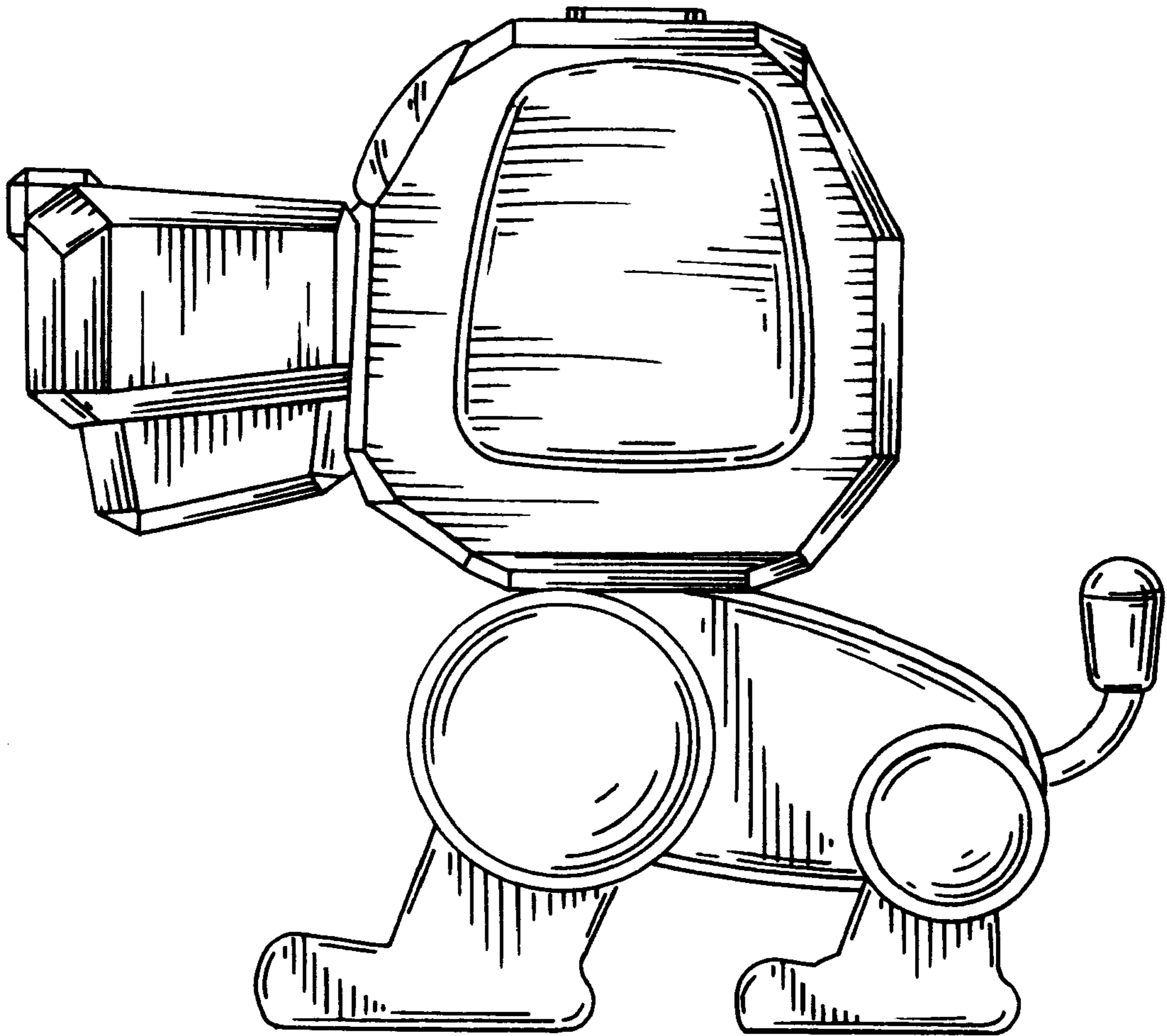

FIG. 5

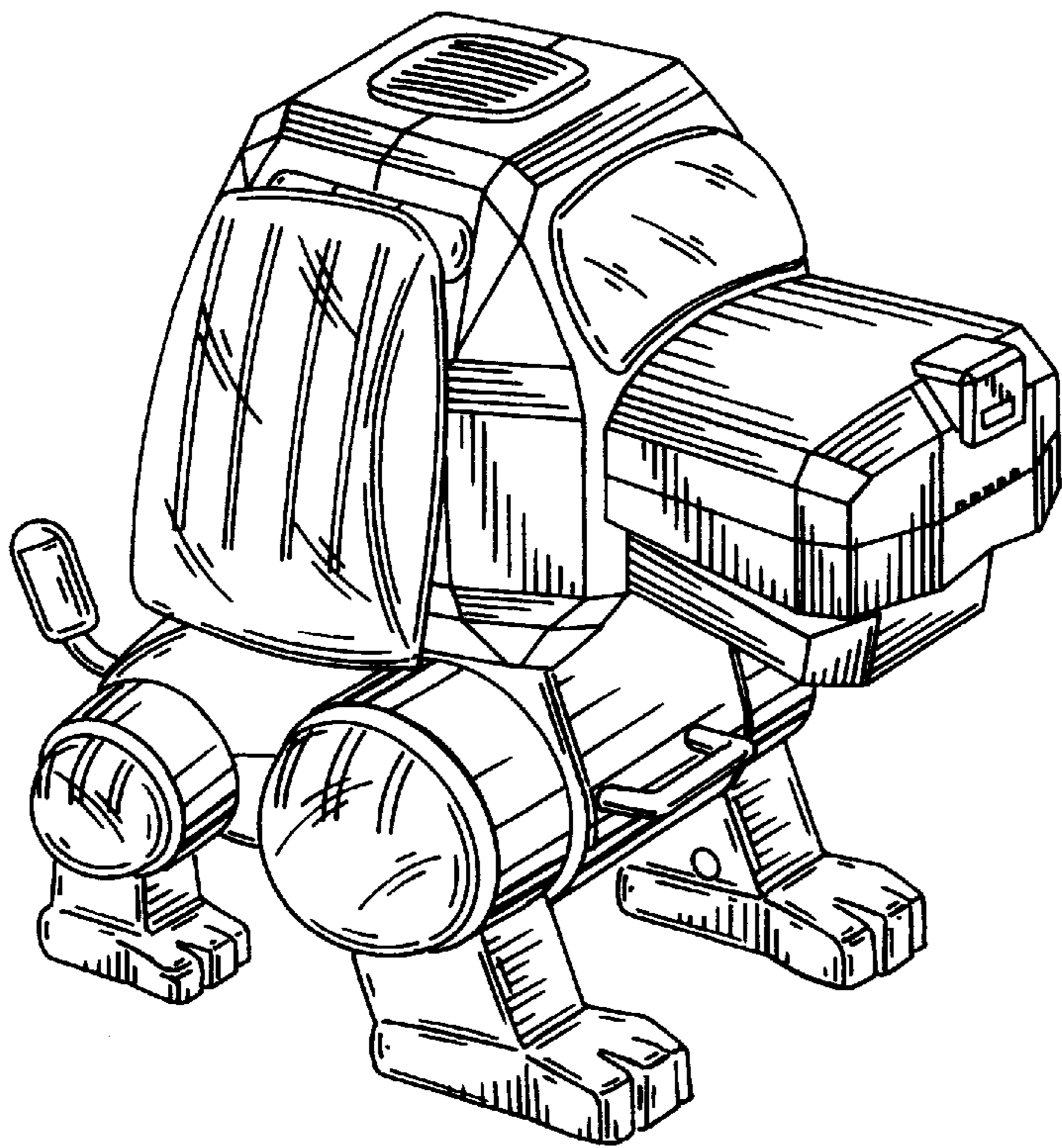

FIG. 6

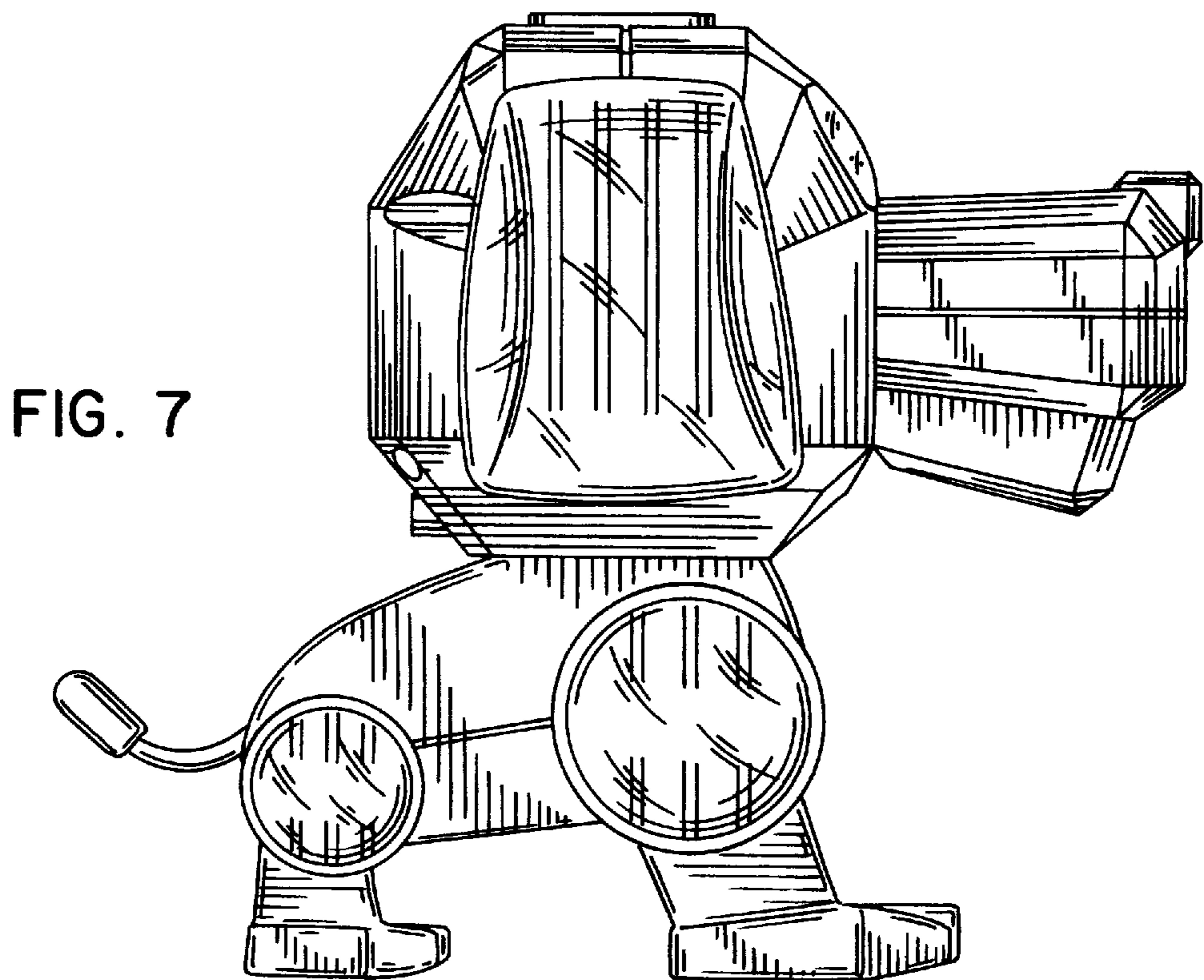

FIG. 7

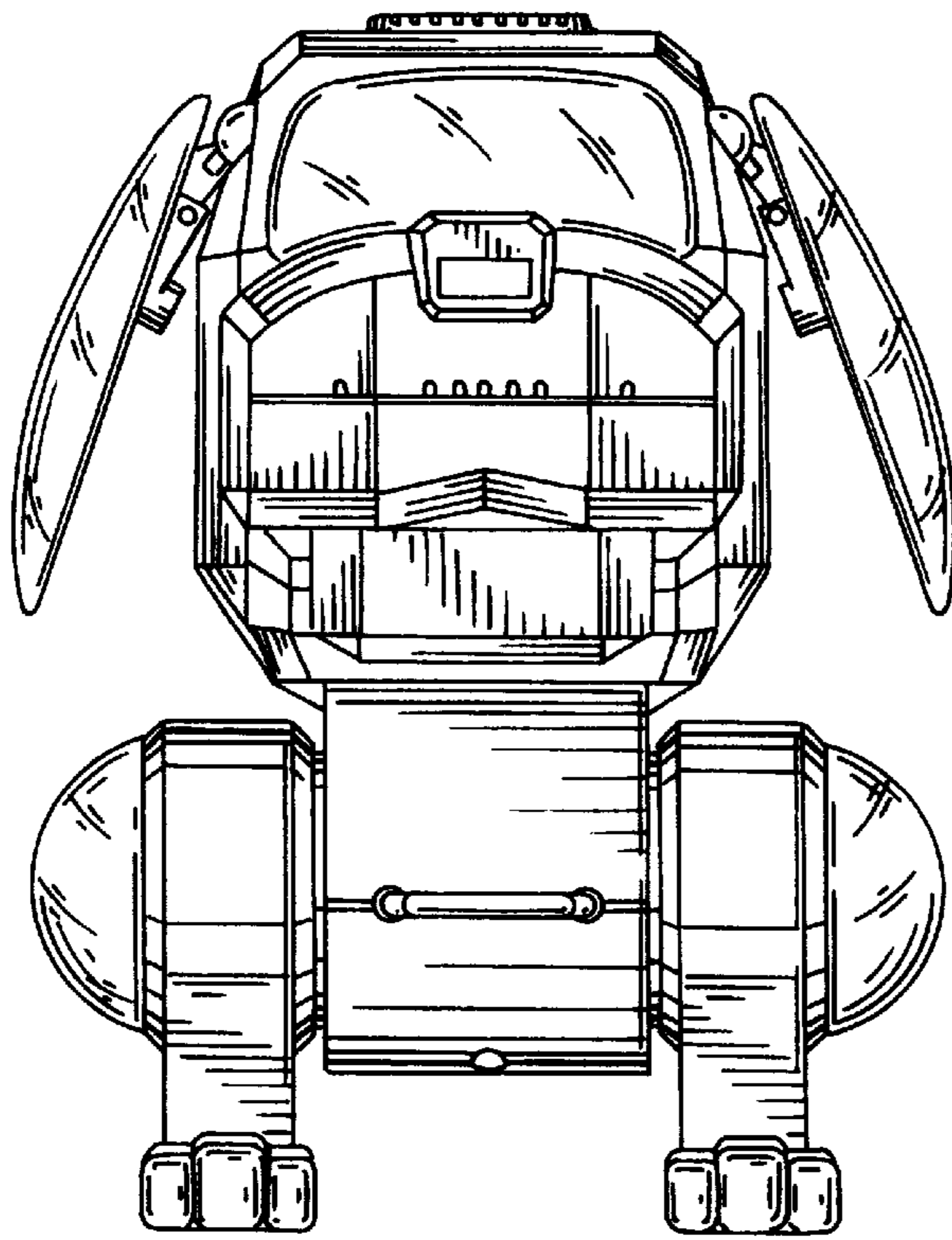

FIG. 8

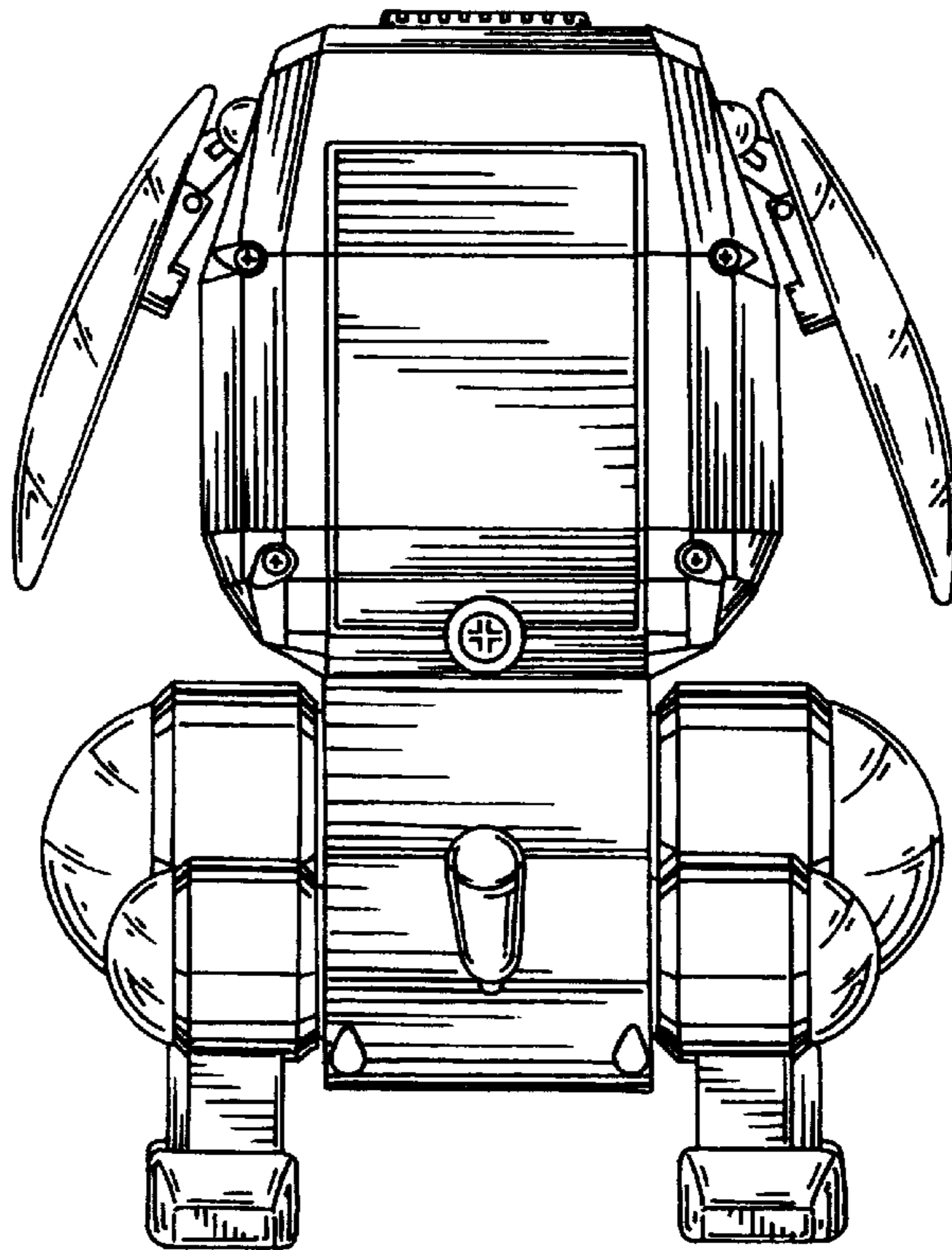

FIG. 9

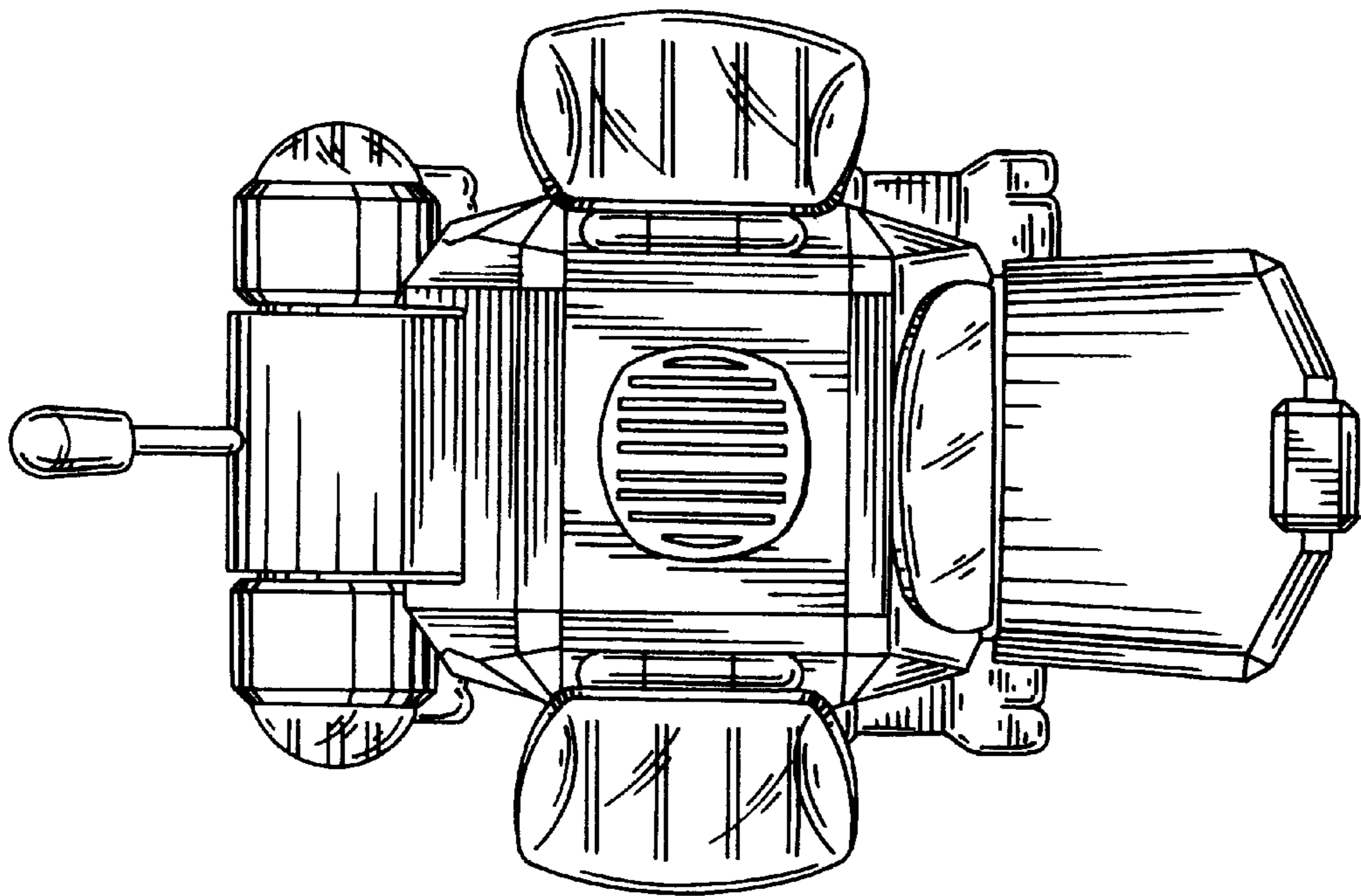

FIG. 10

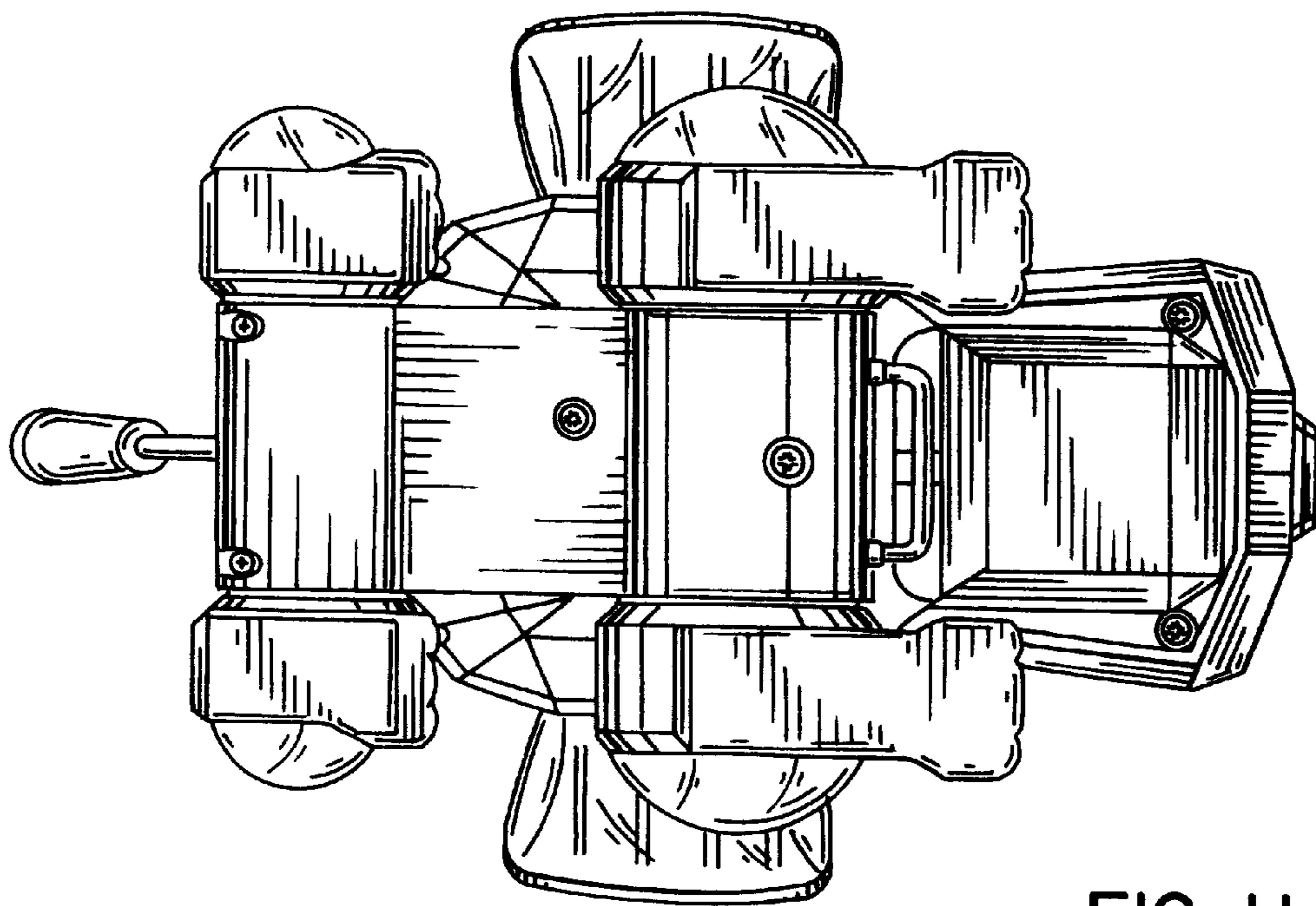

FIG. 11

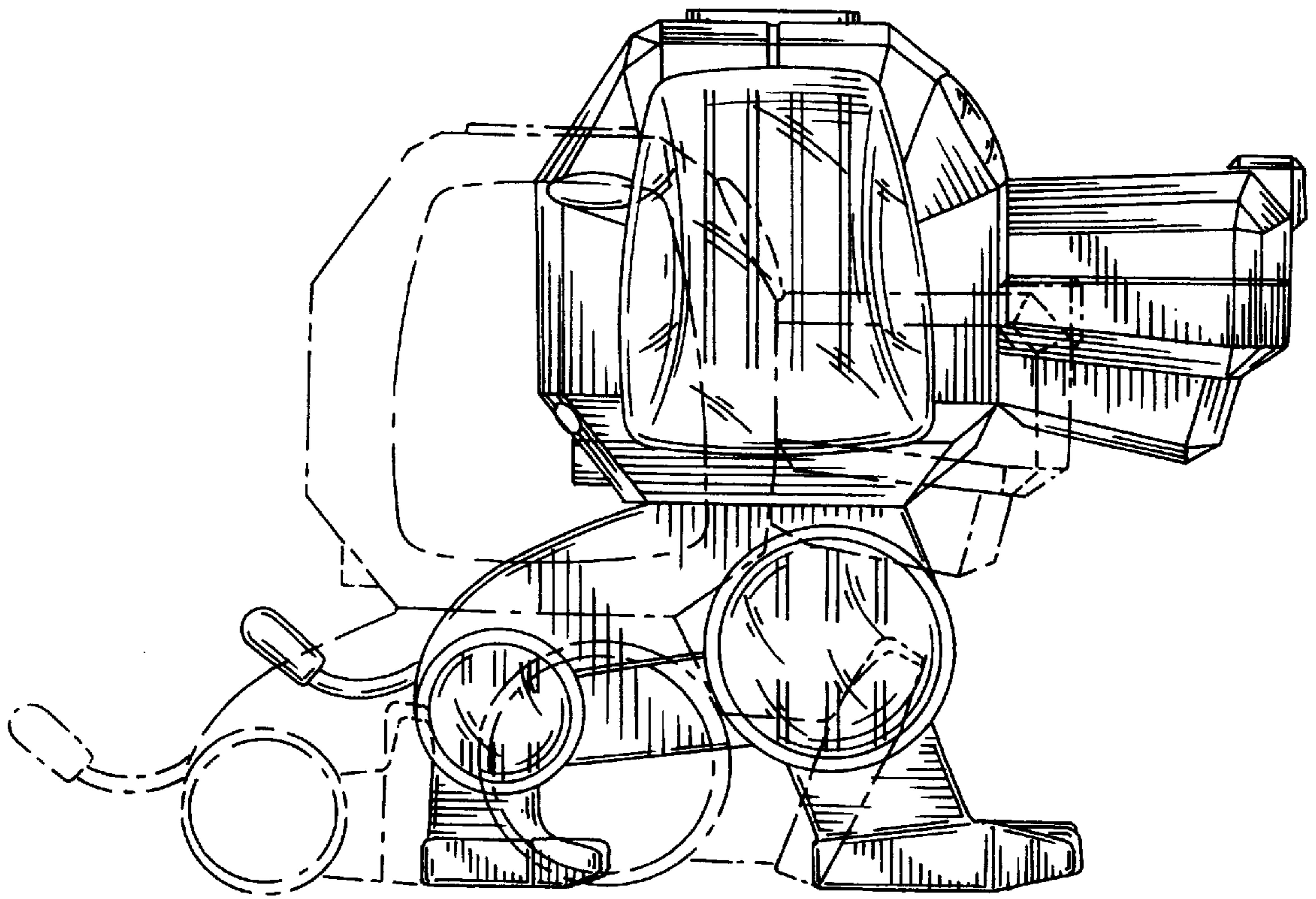

FIG. 12