



US00D448136B1

(12) **United States Design Patent**  
**Yurushi et al.**

(10) **Patent No.:** **US D448,136 S**

(45) **Date of Patent:** **\*\* Sep. 18, 2001**

(54) **FORK LIFT TRUCK**

(75) Inventors: **Toshiyuki Yurushi; Joji Tominaga;**  
**Yoshiyuki Enmeiji; Masafumi**  
**Yokoyama, all of Osaka (JP)**

(73) Assignee: **TCM Corporation, Osaka (JP)**

(\*\*) Term: **14 Years**

(21) Appl. No.: **29/125,985**

(22) Filed: **Jul. 6, 2000**

(30) **Foreign Application Priority Data**

Mar. 30, 2000 (JP) ..... 12-007993

(51) **LOC (7) Cl.** ..... **12-05**

(52) **U.S. Cl.** ..... **D34/34**

(58) **Field of Search** ..... D34/34, 35, 37;  
D12/14-15, 93, 94; 180/89.12, 89.17, 89.14;  
280/402; 414/579, 785, 607

(56) **References Cited**

**U.S. PATENT DOCUMENTS**

- D. 346,259 \* 4/1994 Laatsch ..... D34/34
- D. 386,872 \* 11/1997 Rick et al. .... D34/34
- D. 389,981 \* 1/1998 Donaldson ..... D34/34
- D. 389,982 \* 1/1998 Kim ..... D34/34
- D. 393,516 \* 4/1998 Hahn et al. .... D34/34
- D. 395,115 \* 6/1998 Russey et al. .... D34/34
- D. 395,532 \* 6/1998 Kim ..... D34/34
- D. 396,928 \* 8/1998 Hahn et al. .... D34/34

- D. 412,385 \* 7/1999 Murakami et al. .... D34/34
- D. 427,409 \* 6/2000 Sato et al. .... D34/34
- D. 432,753 \* 10/2000 Braud ..... D34/34

\* cited by examiner

*Primary Examiner*—Cynthia E. Ramirez

(74) *Attorney, Agent, or Firm*—Fildes & Outland, P.C.

(57) **CLAIM**

The ornamental design for a fork lift truck, as shown and described.

**DESCRIPTION**

FIG. 1 is a front elevational view of a fork lift truck showing our new design;

FIG. 2 is a rear elevational view thereof;

FIG. 3 is a top plan view thereof;

FIG. 4 is a bottom plan view thereof;

FIG. 5 is a right side elevational view thereof;

FIG. 6 is a left side elevational view thereof;

FIG. 7 is a sectional plan view thereof taken along line 7—7 in FIG. 5;

FIG. 8 is a perspective view thereof from the right front;

FIG. 9 is a perspective view thereof from the left rear;

FIG. 10 is a right side elevational view showing the wheels in an alternate position;

FIG. 11 is a perspective view thereof; and,

FIG. 12 is a right side elevational view showing the wheels in yet another alternate position.

**1 Claim, 12 Drawing Sheets**

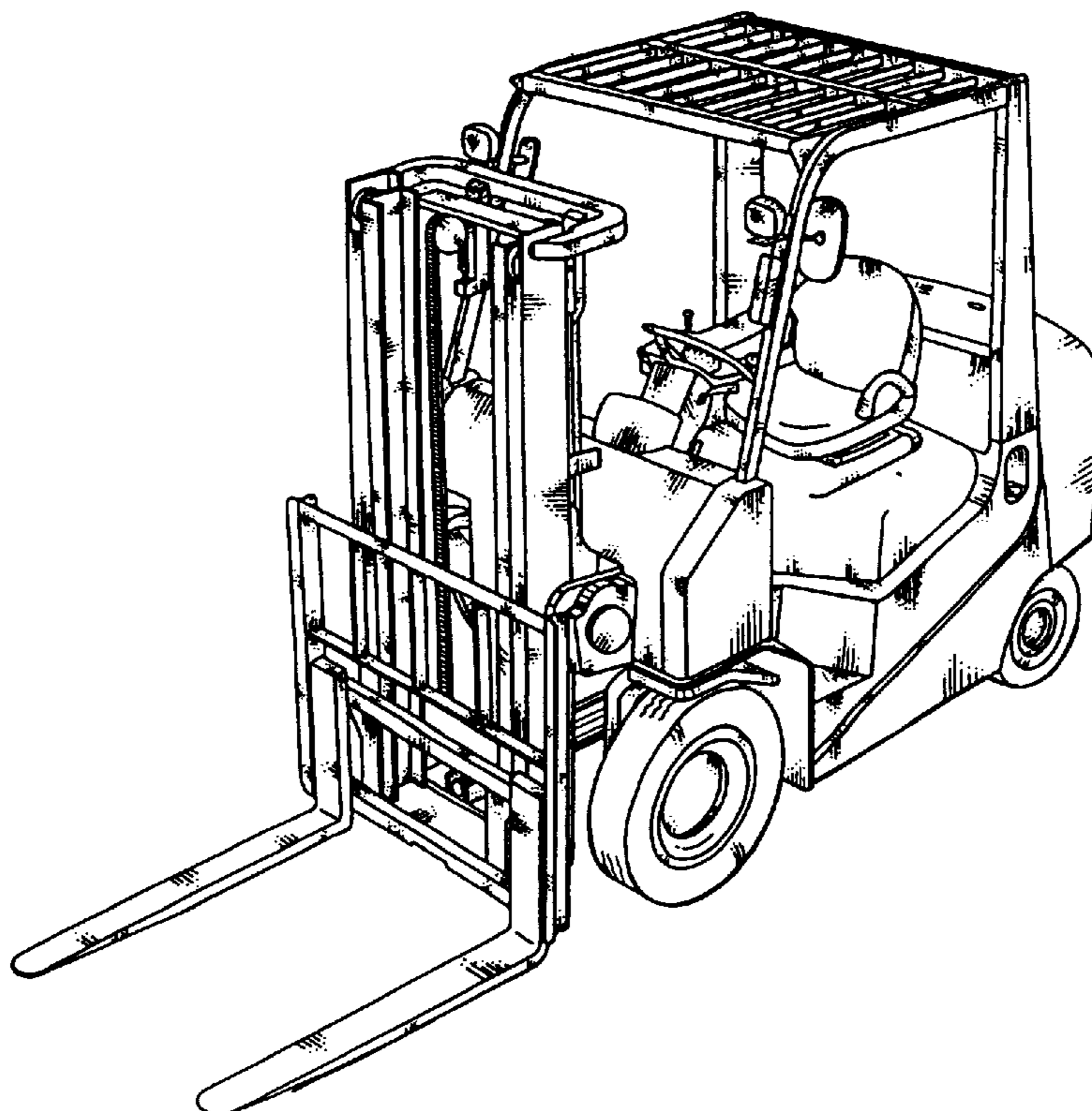

FIG-1

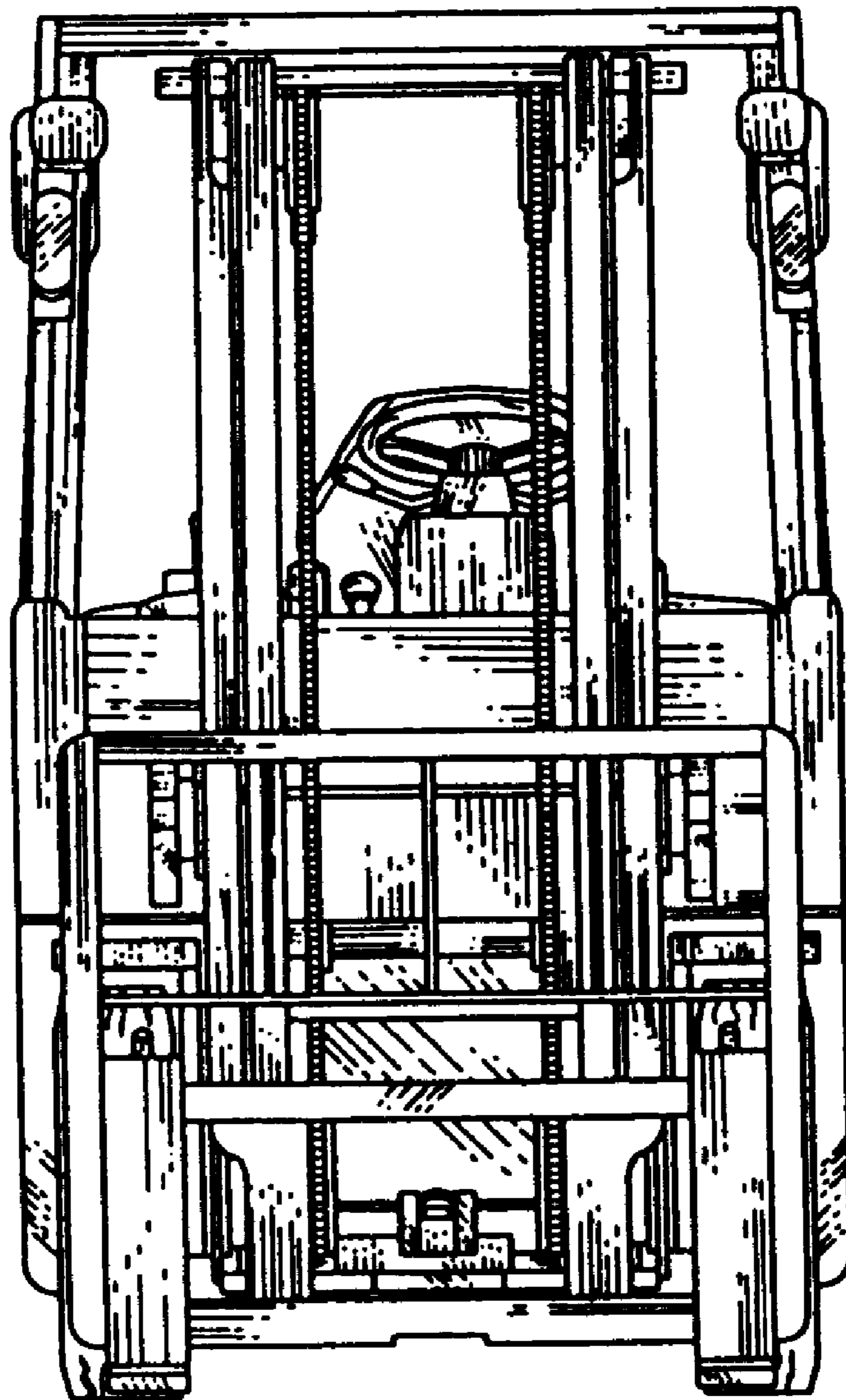

FIG-2

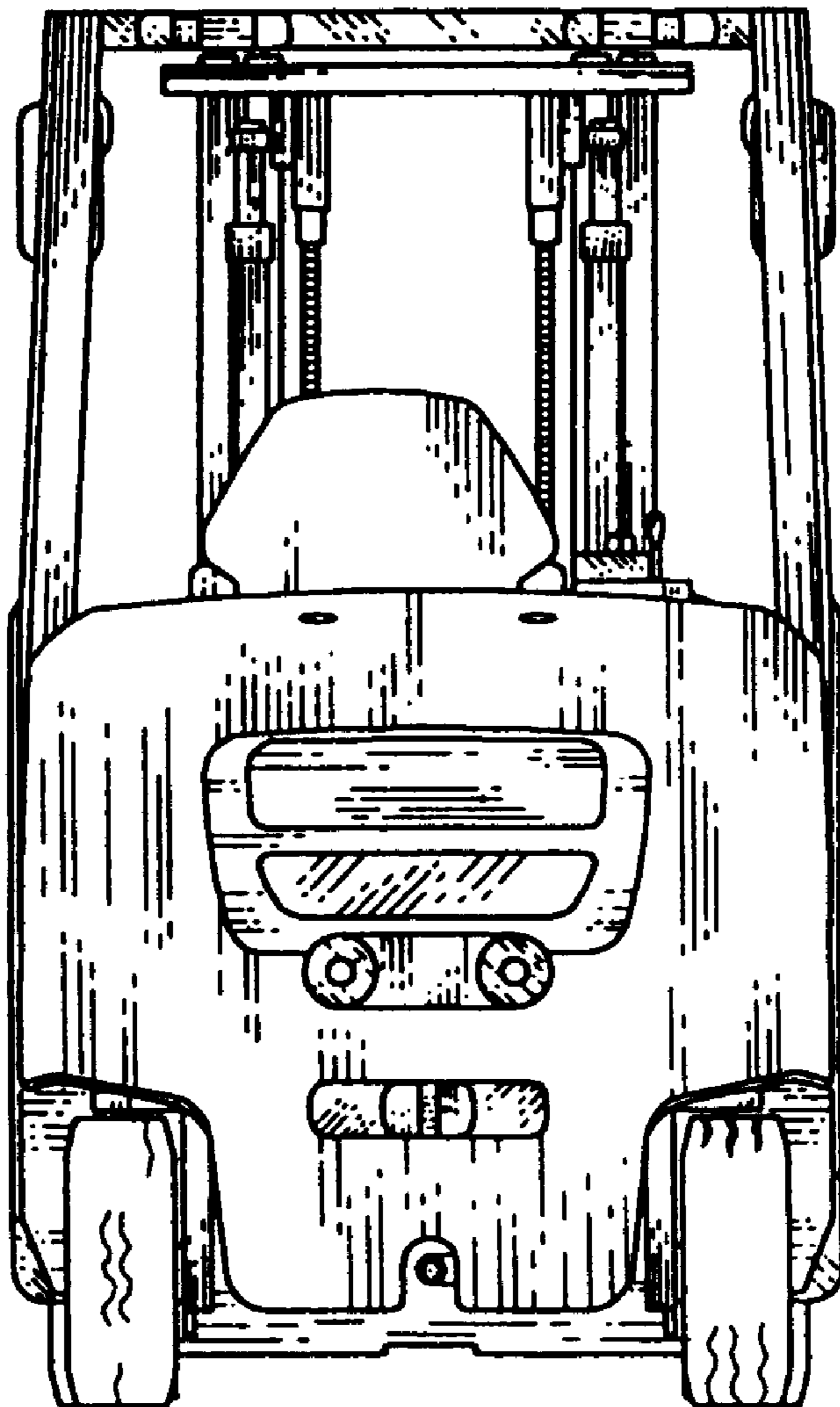

FIG-3

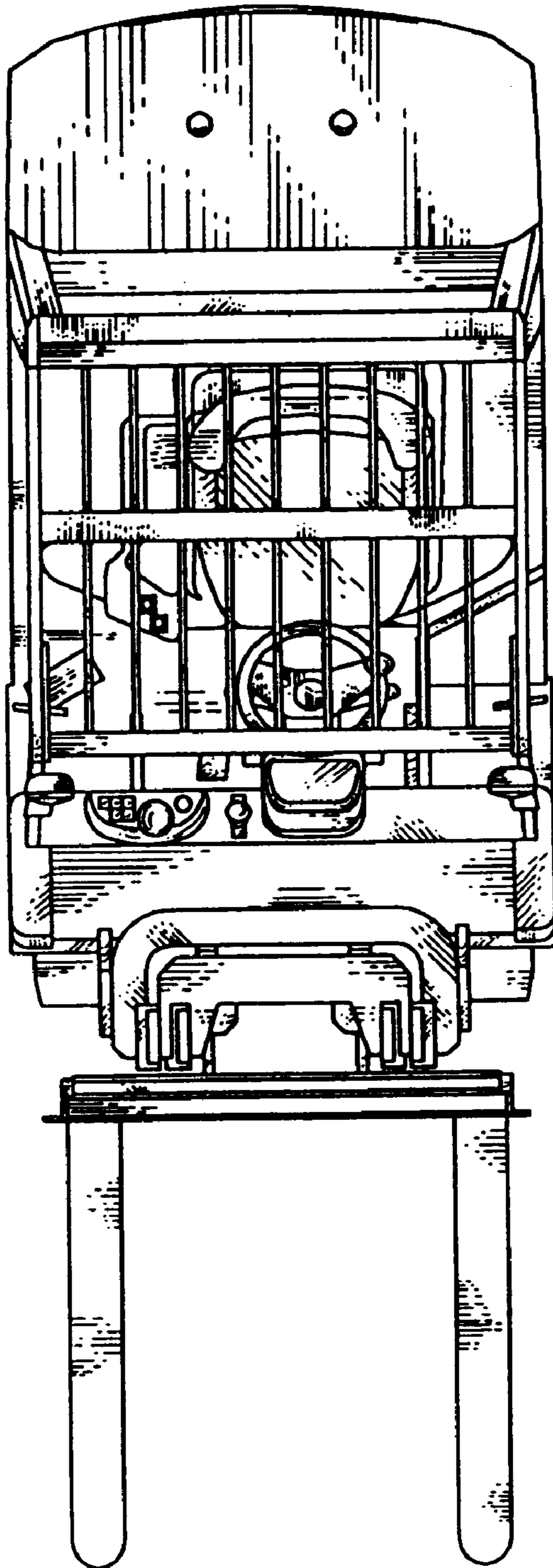

FIG-4

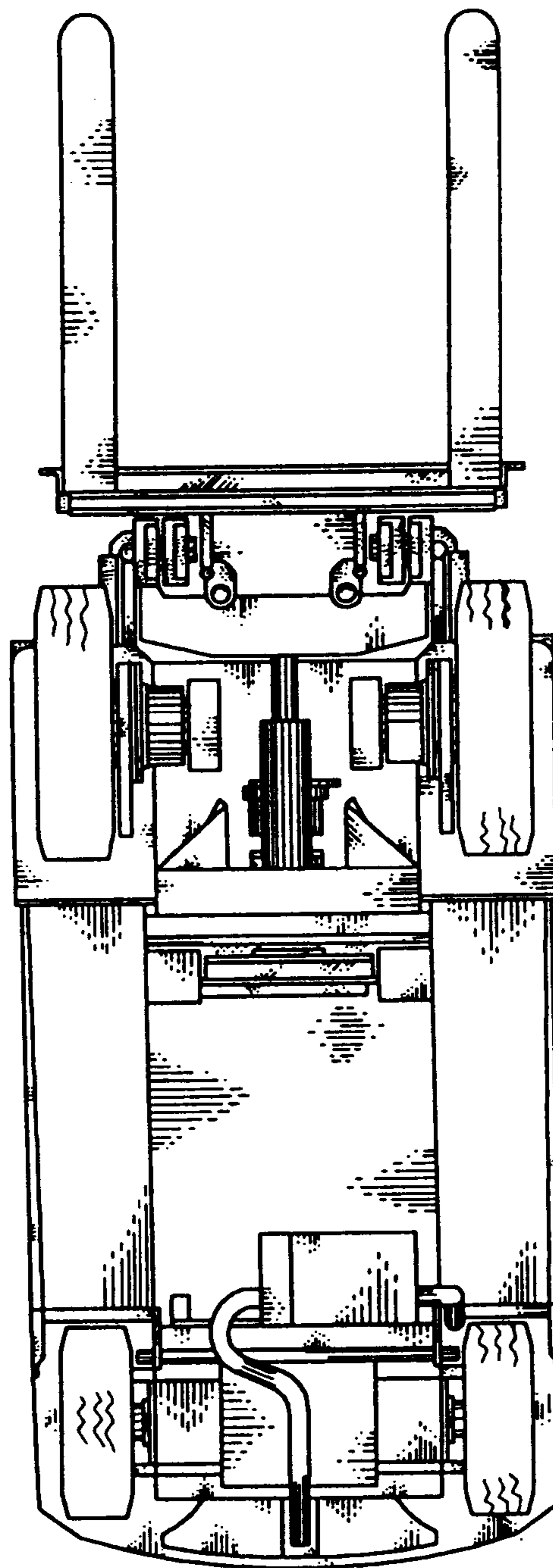

FIG-5

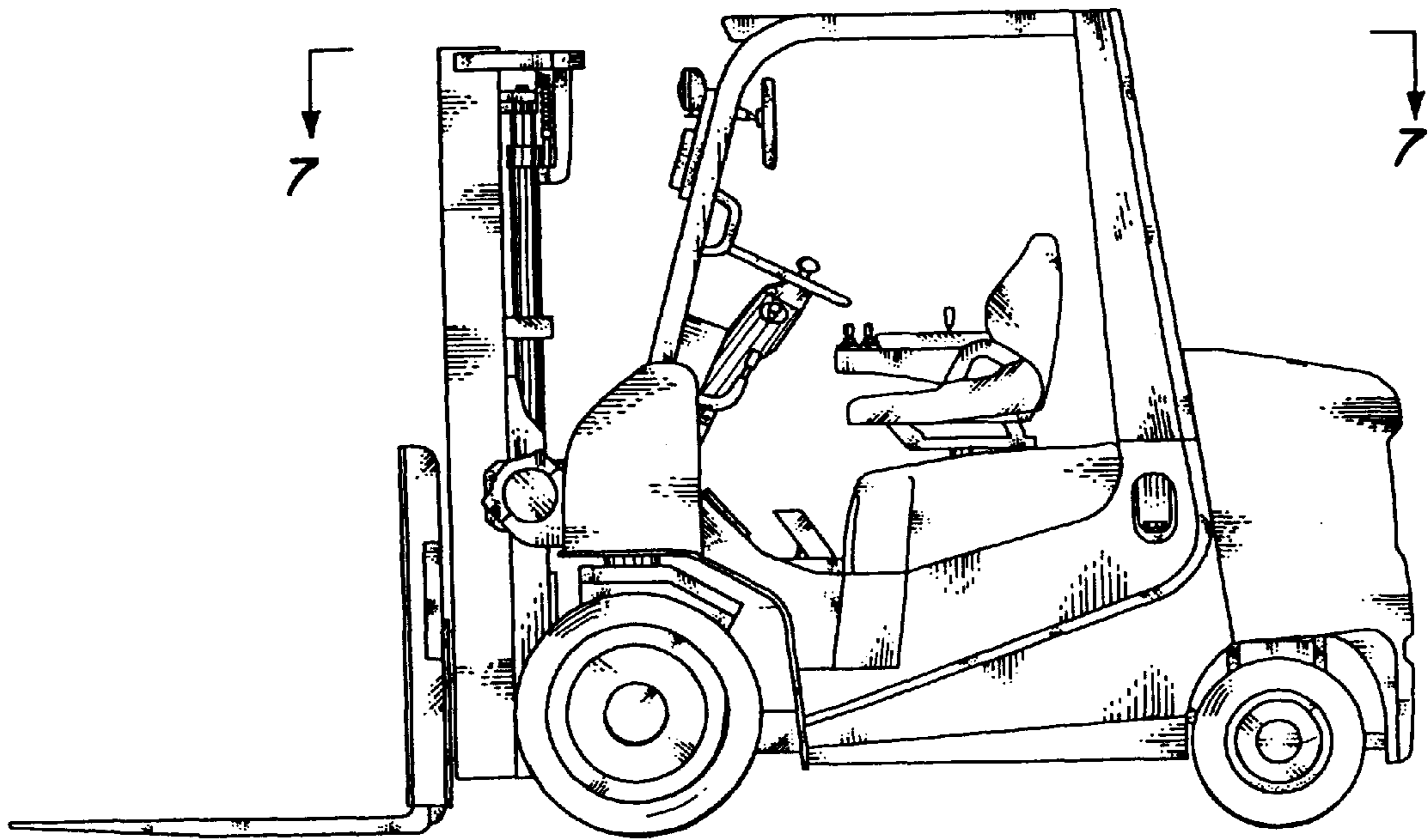

FIG-6

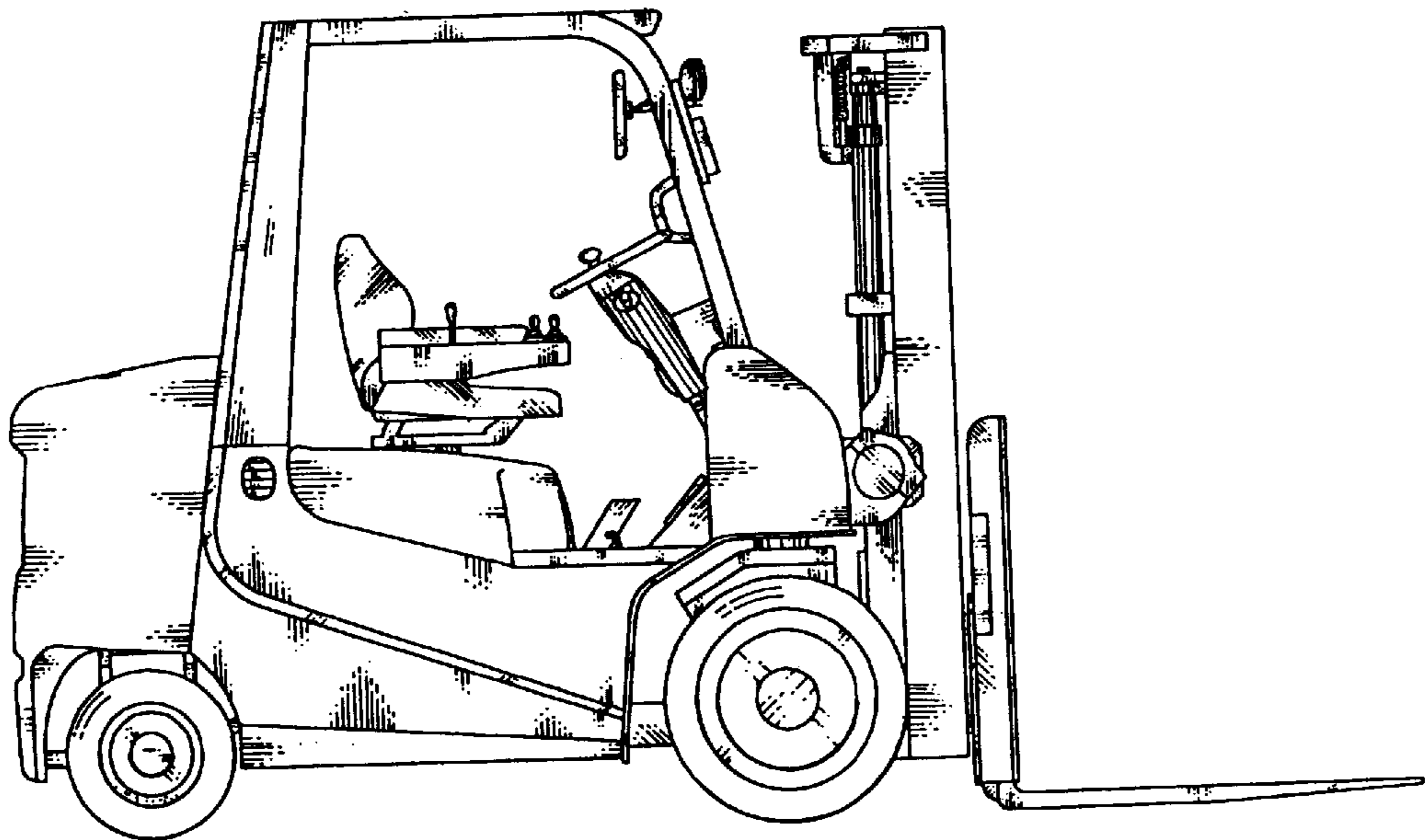

FIG-7

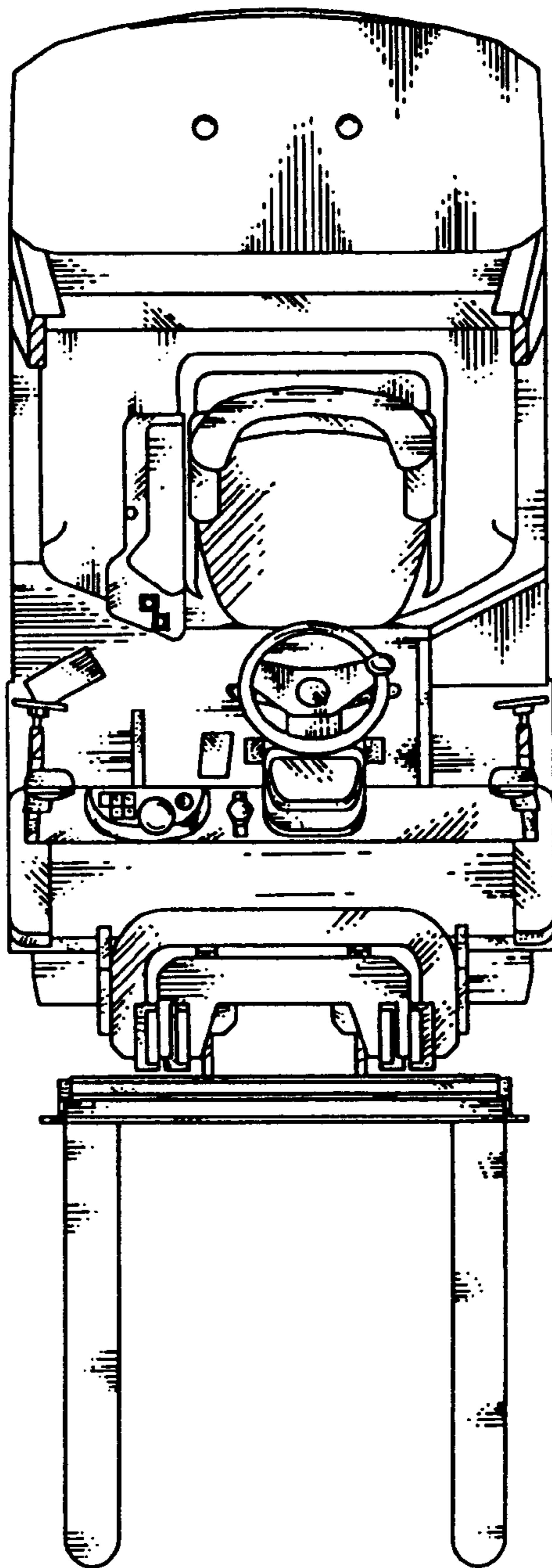



FIG-8

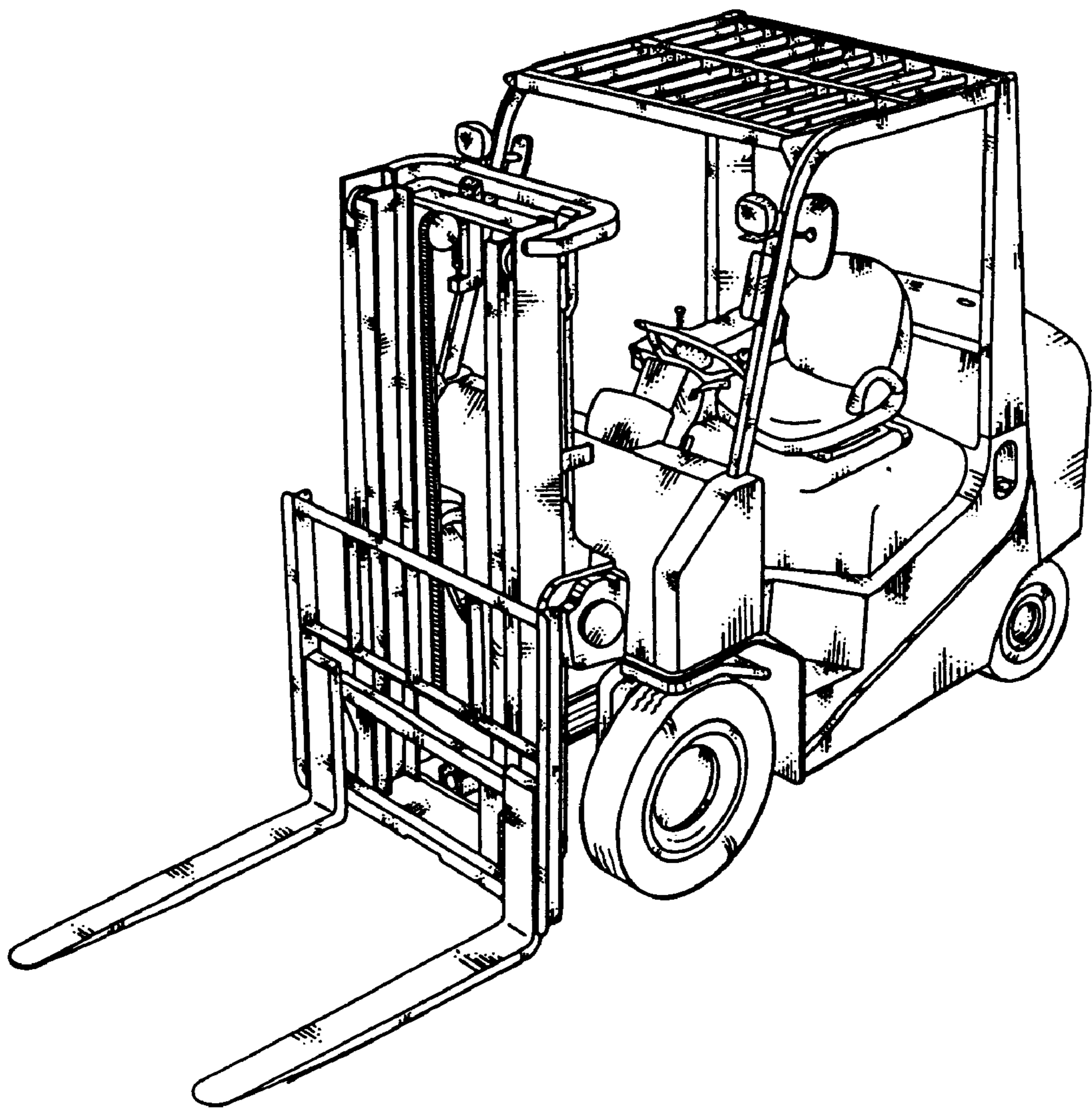

FIG-9

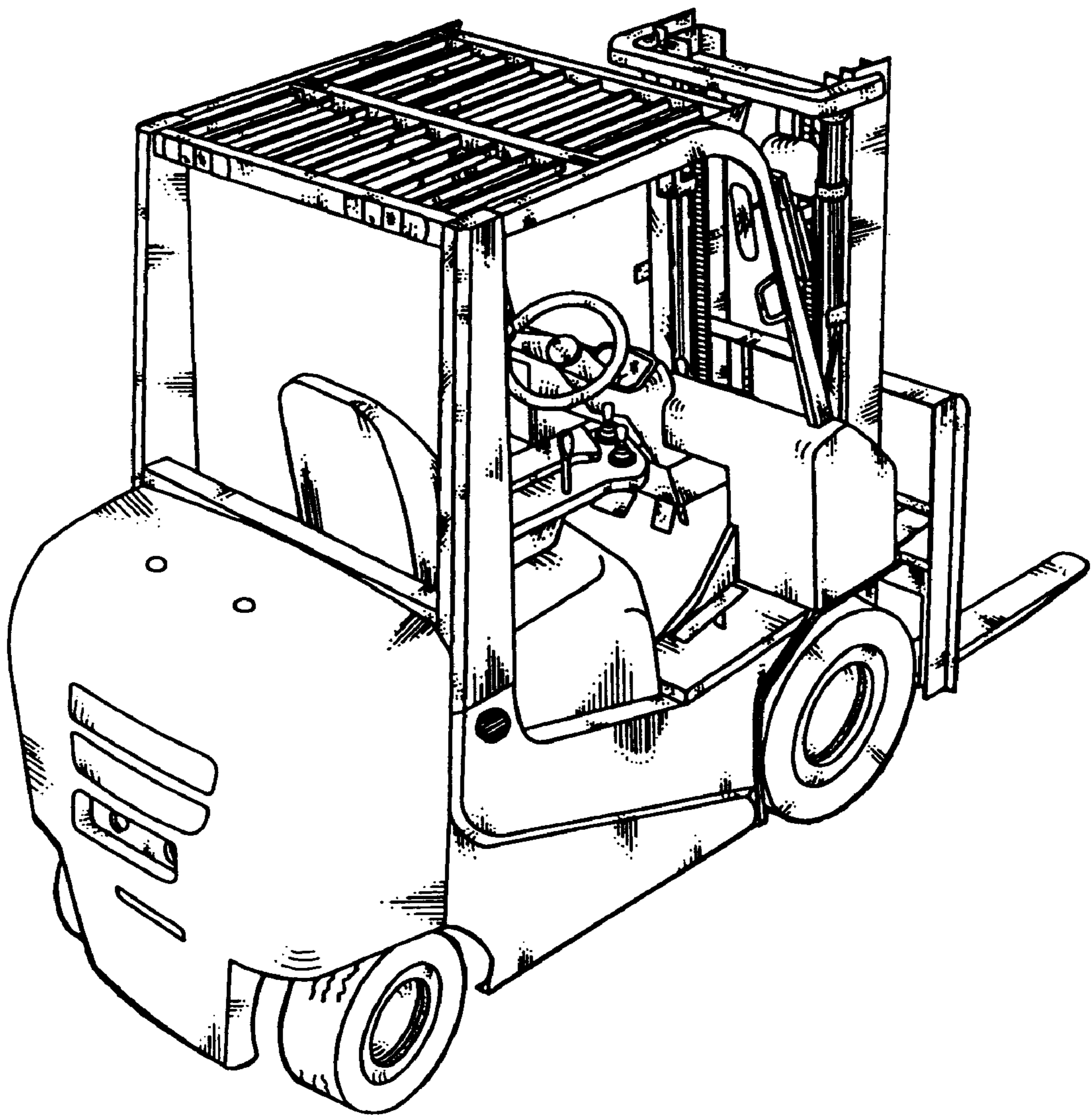

FIG-10

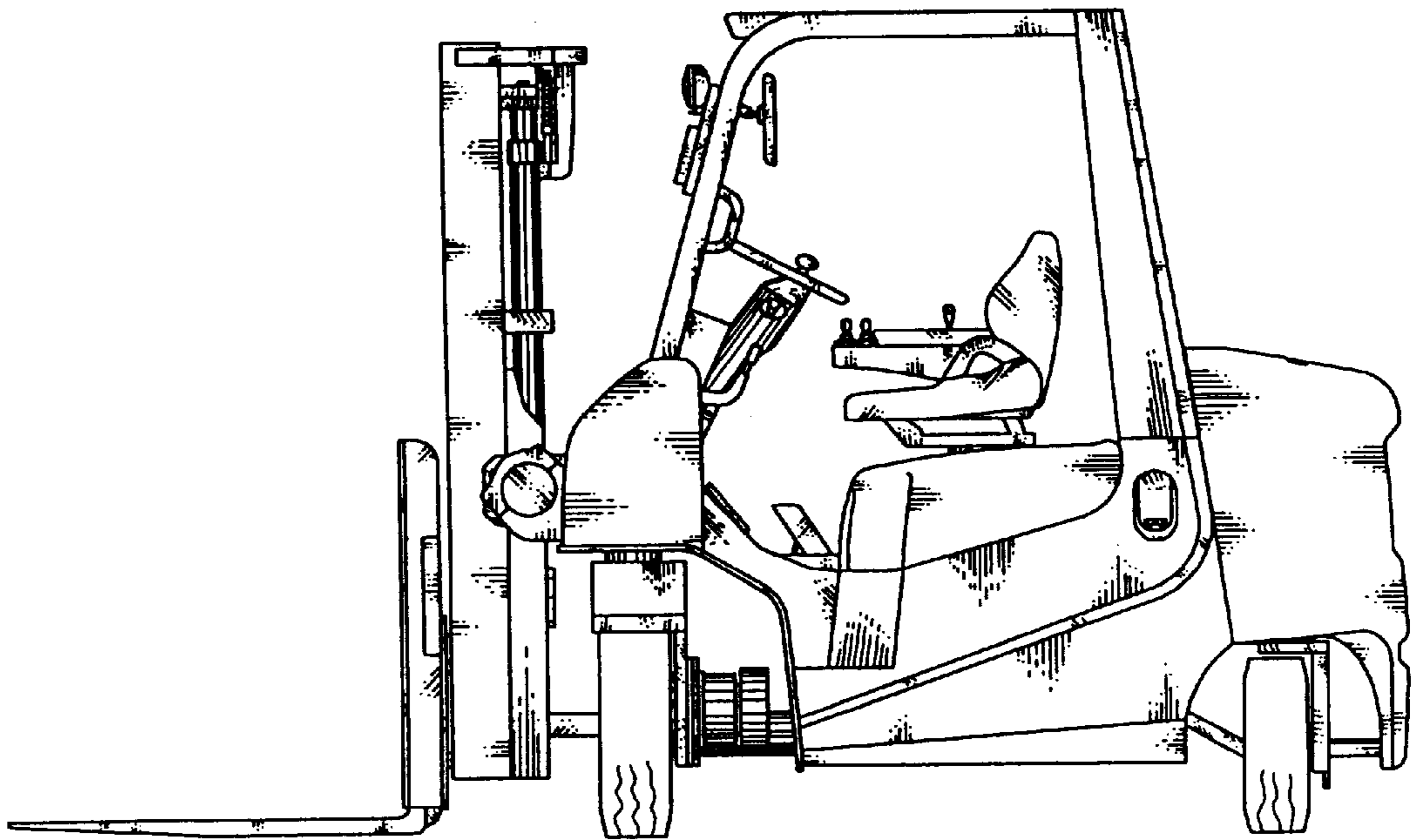

FIG-11

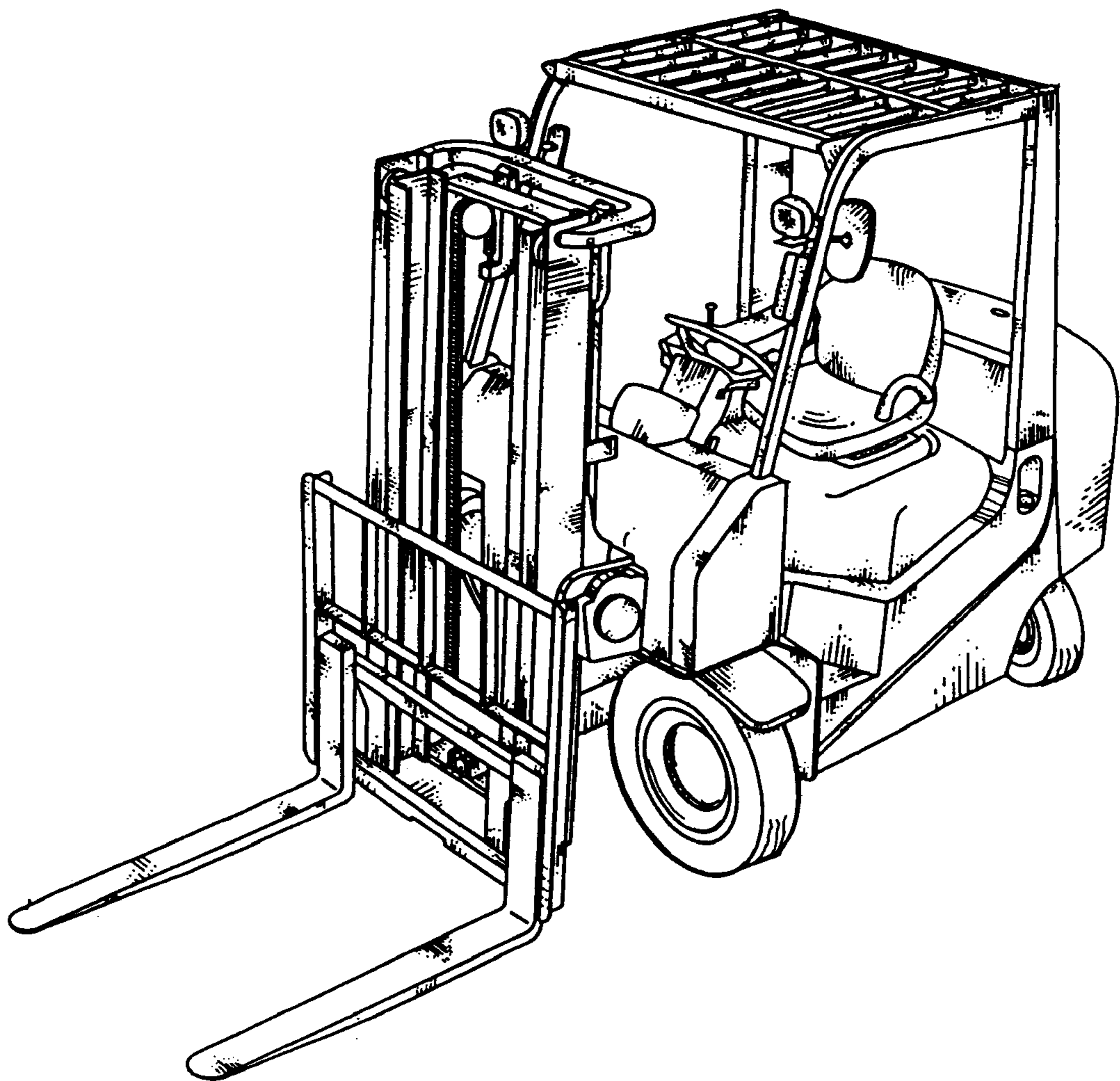

FIG-12

