



US00D448004B1

(12) **United States Design Patent**  
Asao et al.

(10) **Patent No.:** **US D448,004 S**  
(45) **Date of Patent:** **\*\* Sep. 18, 2001**

(54) **STATOR OF AC GENERATOR FOR VEHICLES**

(75) Inventors: **Yoshihito Asao; Katsumi Adachi; Akira Morishita**, all of Tokyo (JP)

(73) Assignee: **Mitsubishi Denki Kabushiki Kaisha**, Tokyo (JP)

(\*\*) Term: **14 Years**

(21) Appl. No.: **29/124,820**

(22) Filed: **Jun. 13, 2000**

(30) **Foreign Application Priority Data**

Dec. 14, 1999 (JP) ..... 11-34428

(51) **LOC (7) Cl.** ..... **13-02**

(52) **U.S. Cl.** ..... **D13/122**

(58) **Field of Search** ..... D13/118, 122;  
310/92, 179, 180, 201, 254-260

(56) **References Cited**

**U.S. PATENT DOCUMENTS**

D. 425,857	*	5/2000	Umeda et al.	.....	D13/118
D. 426,191	*	6/2000	Umeda et al.	.....	D13/122
3,453,468	*	7/1969	Lund	.....	310/180
4,741,098	*	5/1988	Barrera	.....	29/736
5,640,062	*	6/1997	Yockey	.....	310/68 D
5,998,903	*	12/1999	Umeda et al.	.....	310/179
6,049,154	*	4/2000	Asao et al.	.....	310/201
6,051,906	*	4/2000	Umeda et al.	.....	310/179

**FOREIGN PATENT DOCUMENTS**

0910305A \* 4/1997 (JP) ..... H02K/15/02  
1041849 2/2000 (JP) .

**OTHER PUBLICATIONS**

Mitsubishi '93 Automotive Electrical Equipments Parts Catalog (Alternator) (Starting Motor), Feb. 1993.

\* cited by examiner

*Primary Examiner*—Joel Sincavage

(74) *Attorney, Agent, or Firm*—Oblon, Spivak, McClelland, Maier & Neustadt, P.C.

(57) **CLAIM**

The ornamental design for a stator of AC generator for vehicles, as shown and described.

**DESCRIPTION**

FIG. 1 is a front, and top side perspective view of a stator of AC generator for vehicles showing our new design; FIG. 2 is a front elevational view thereof; FIG. 3 is a top plan view thereof; FIG. 4 is a rear elevational view thereof; FIG. 5 is a bottom plan view thereof; FIG. 6 is a right side elevational view thereof; FIG. 7 is a left side elevational view thereof; and, FIG. 8 is a front, and top side reference perspective view showing a part of the armature coils of the stator. The broken line showing in FIG. 8 is included for the purpose of indicating a continuous array of the single armature coil part as shown in FIG. 1.

**1 Claim, 5 Drawing Sheets**

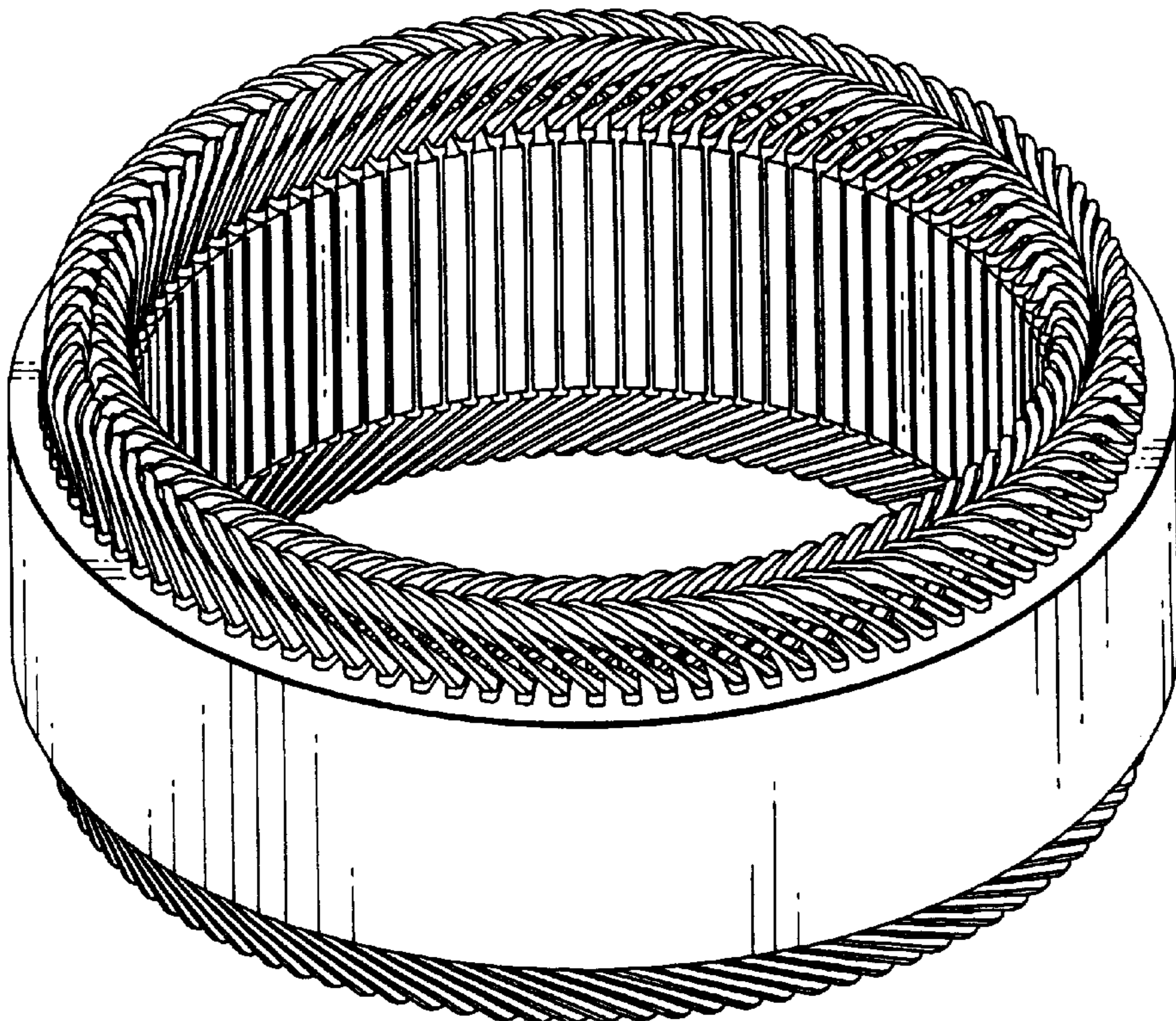

FIG. 1

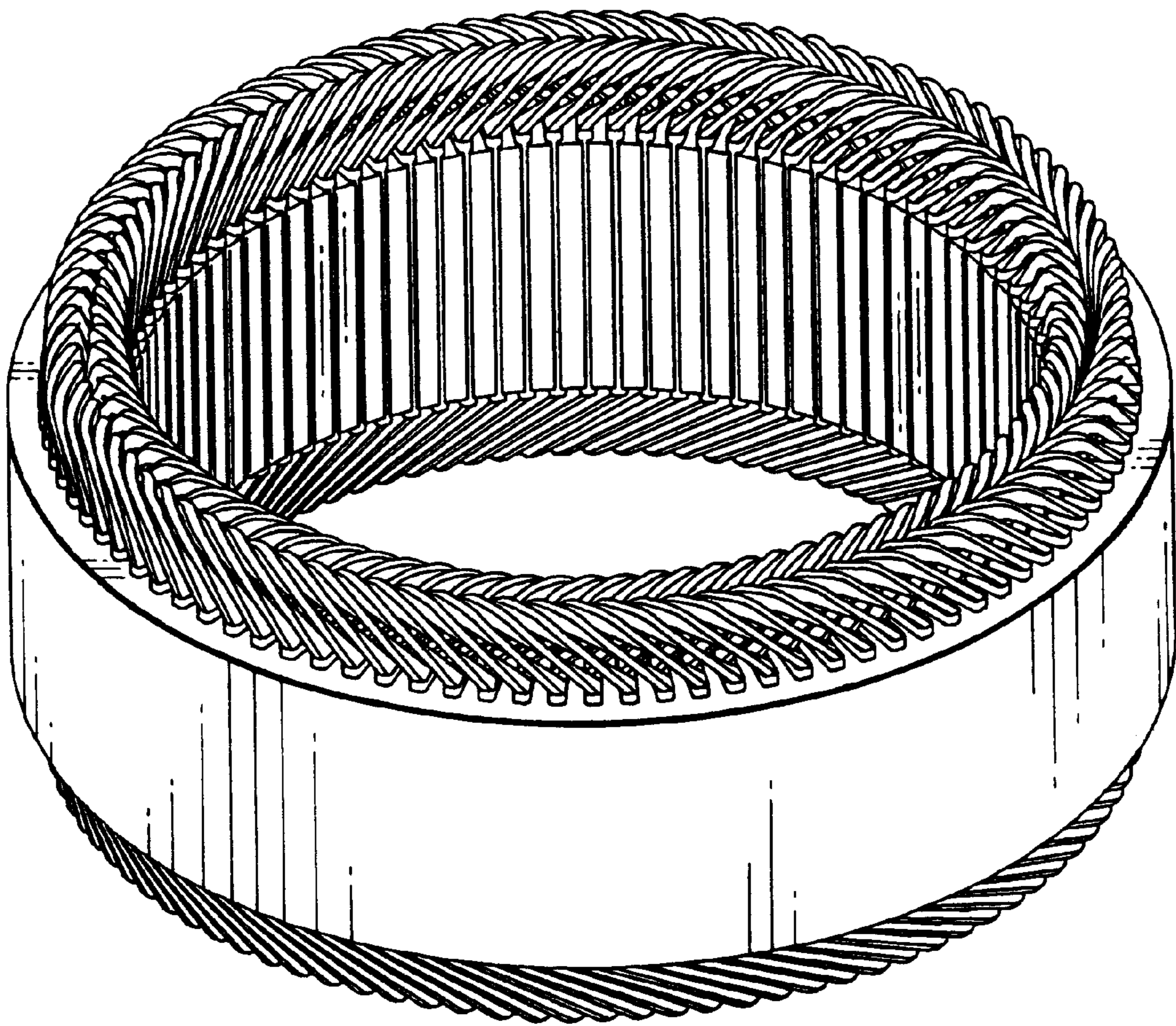

FIG.2

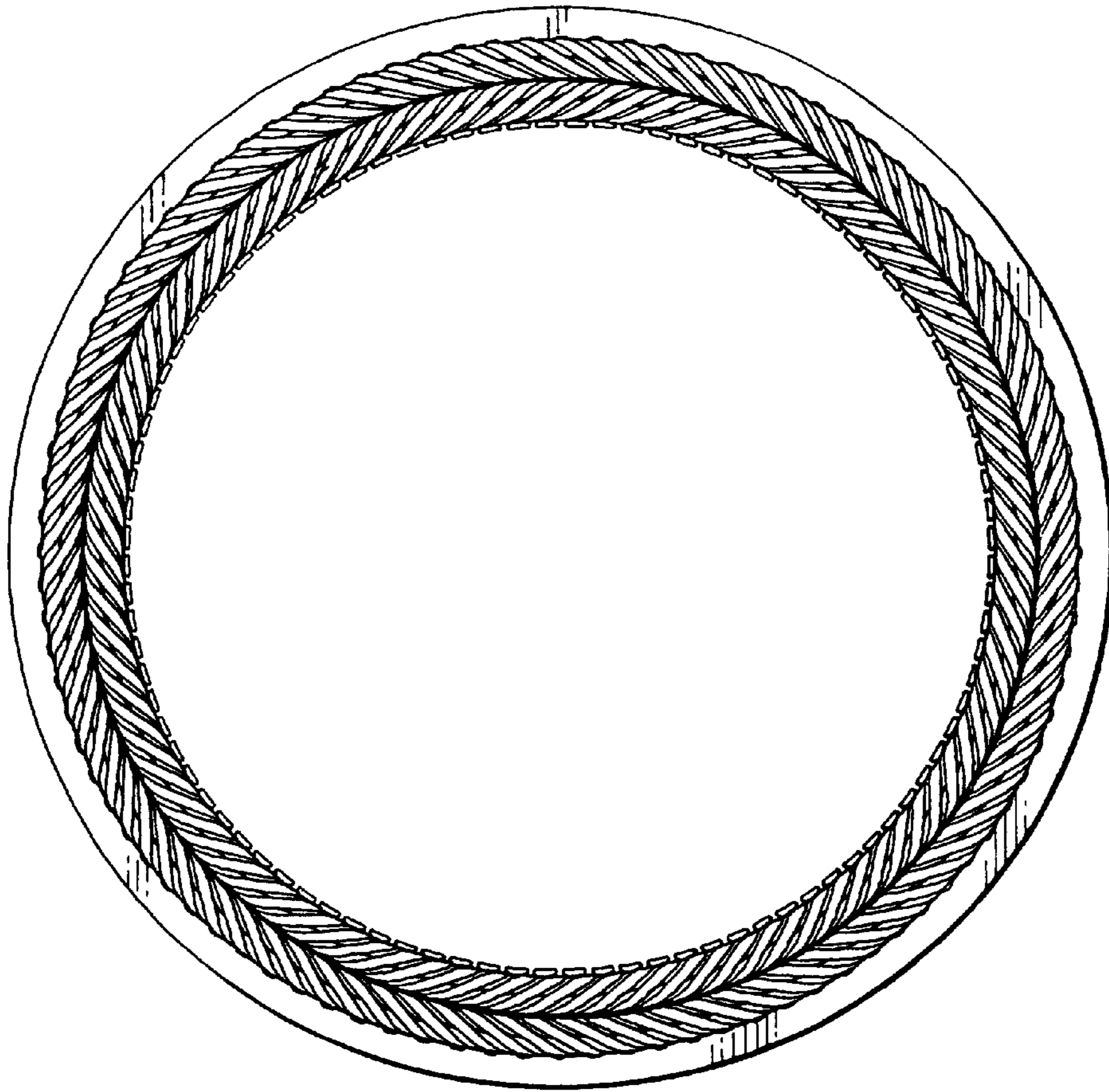

FIG.3

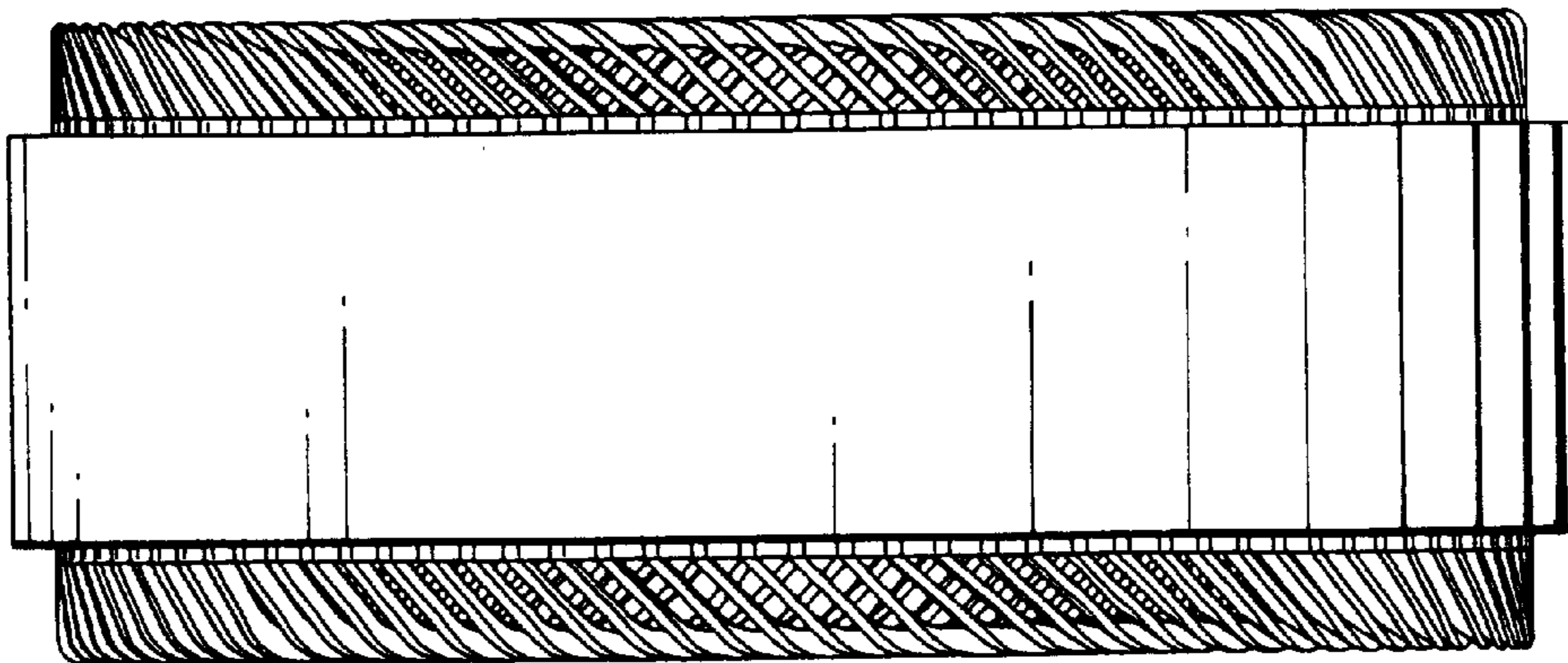

FIG. 4

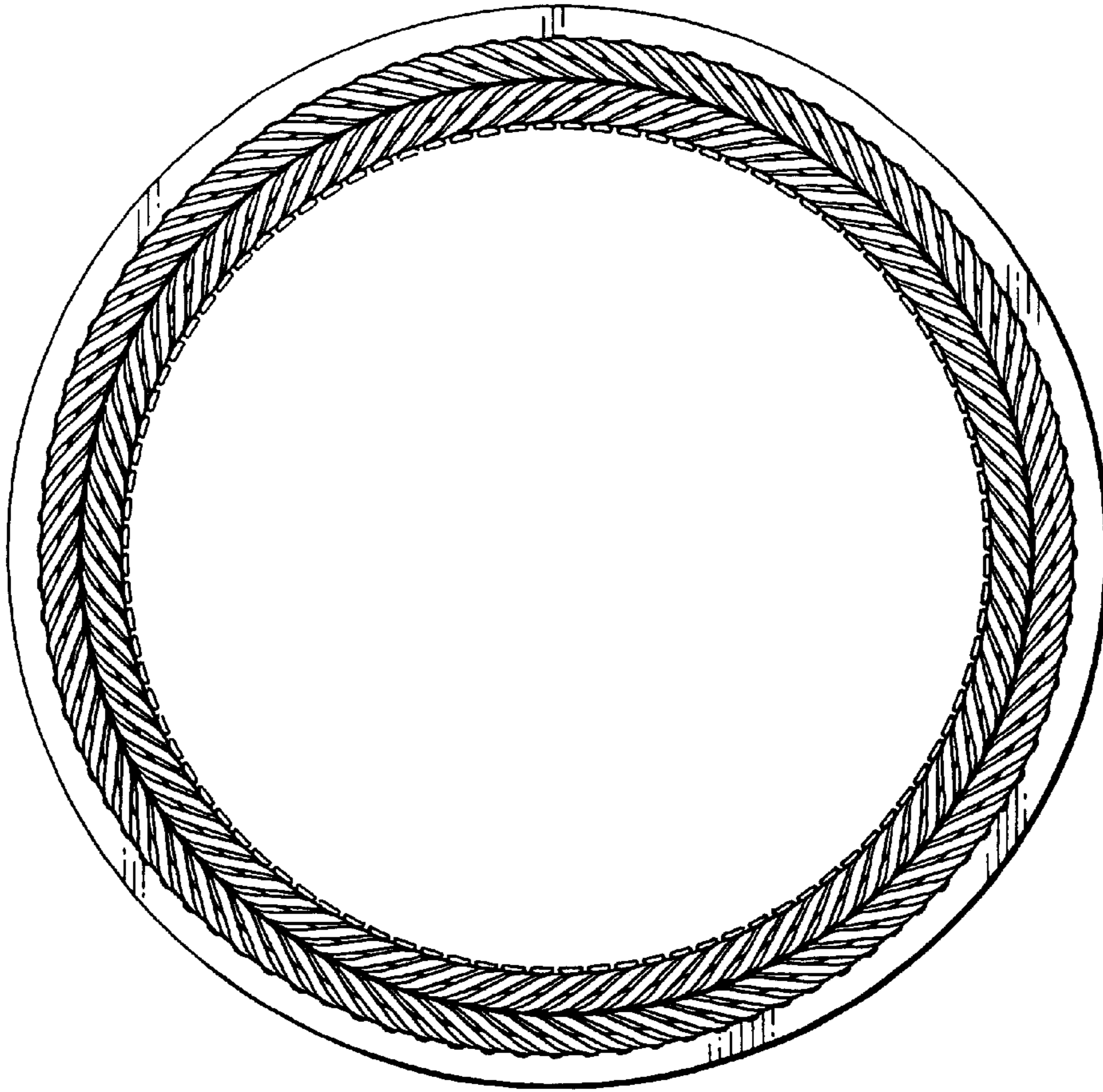

FIG. 5

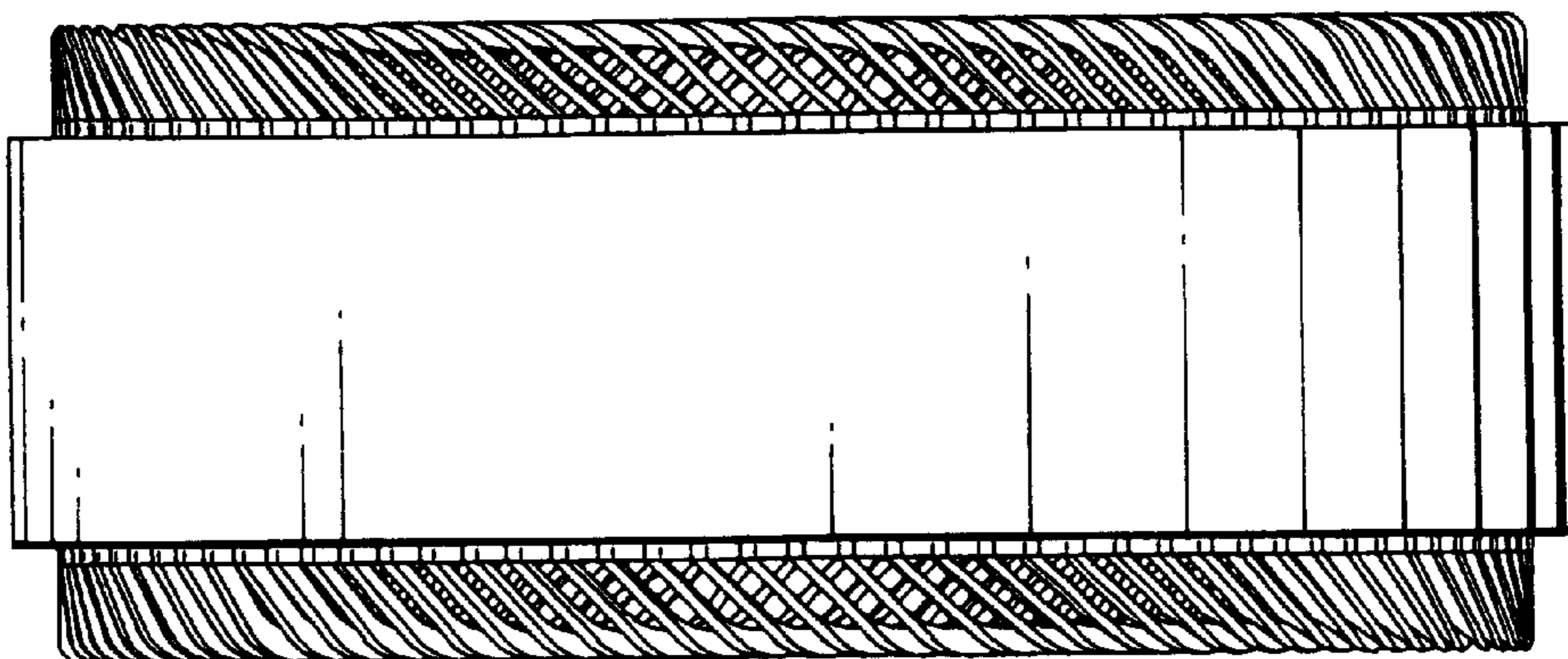

FIG. 6

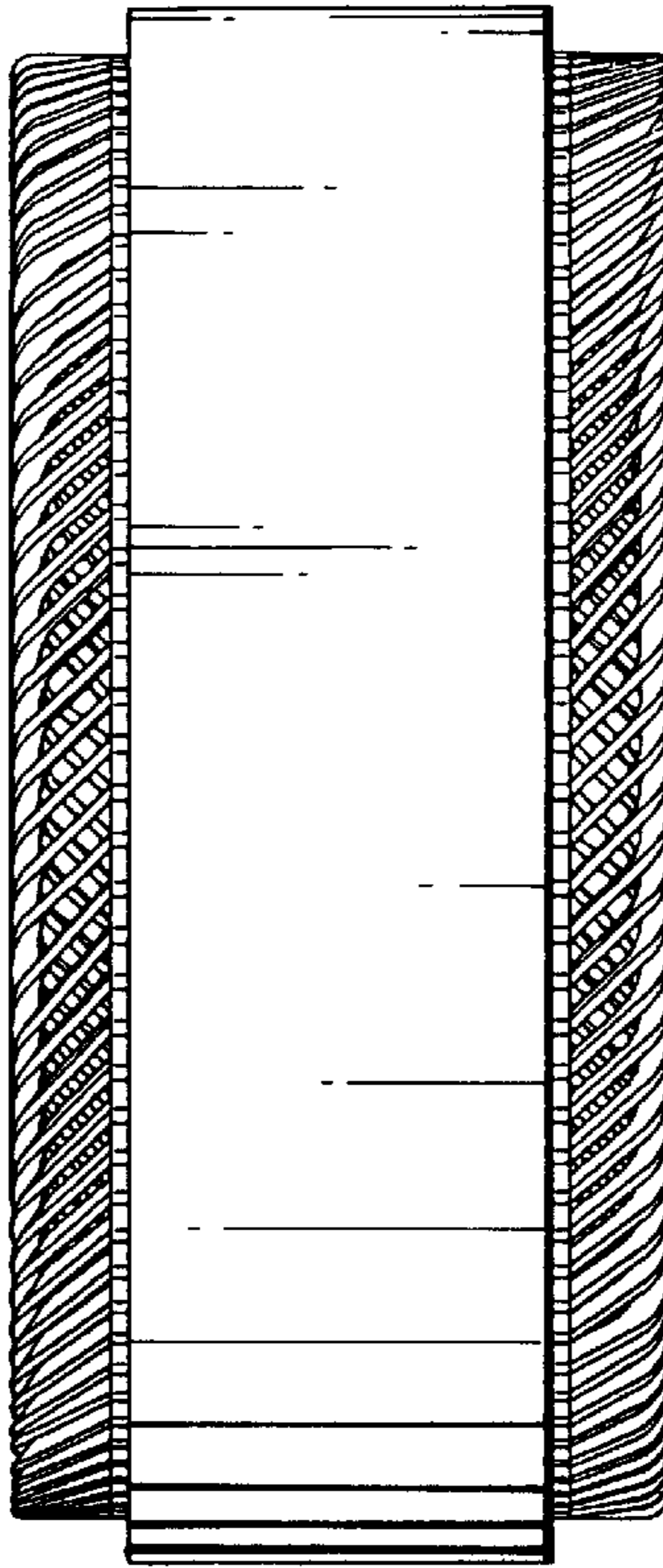

FIG. 7

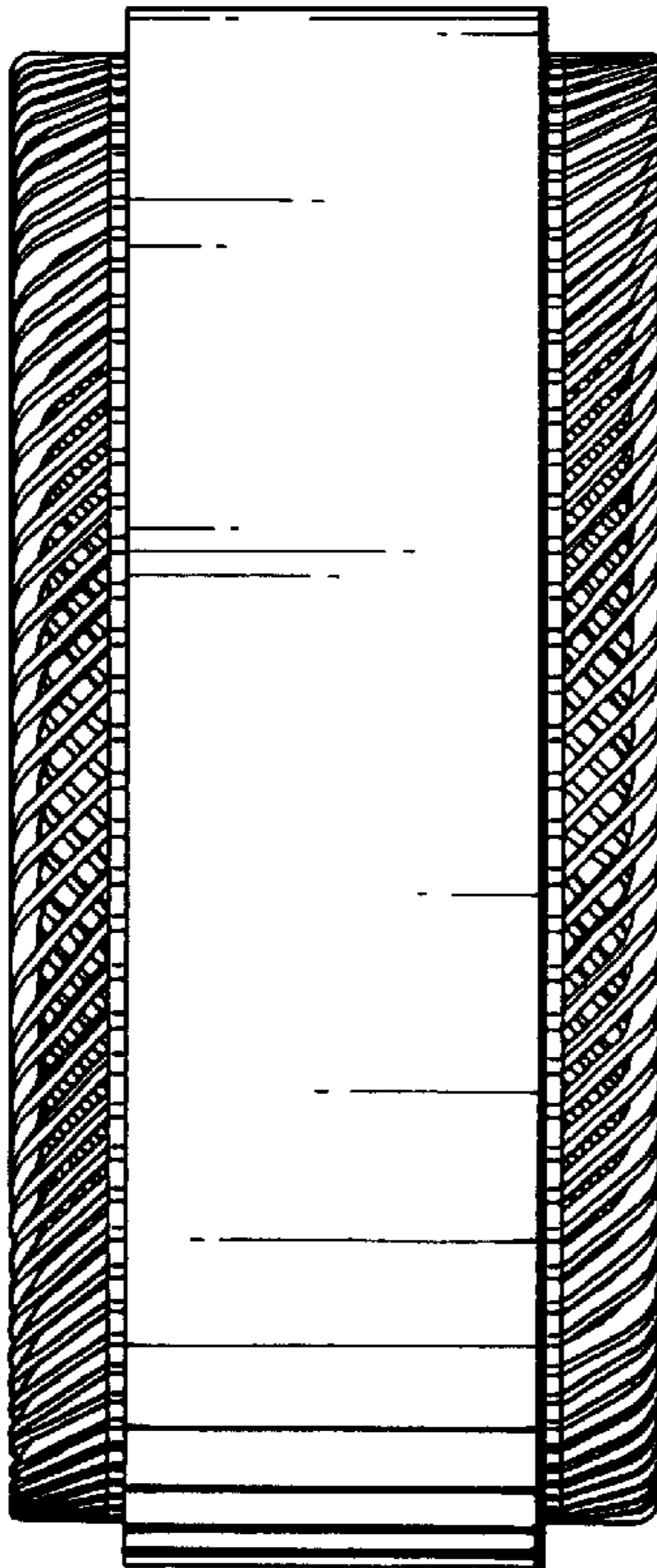

FIG.8

