



US00D447972B1

(12) **United States Design Patent**  
**Igarashi et al.**

(10) **Patent No.:** **US D447,972 S**

(45) **Date of Patent:** **\*\* Sep. 18, 2001**

(54) **AIR FLOW SENSER FOR MOTORCAR**

6,085,587 \* 7/2000 Konzelmann ..... 73/118.2 X  
6,101,869 \* 2/2000 Kadohiro et al. .... 73/118.2 X

(75) Inventors: **Shinya Igarashi**, Naka; **Hiromu Kikawa**, Hitachinaka; **Masayuki Kozawa**, Hitachinaka; **Hitoshi Ishikawa**, Hitachinaka; **Isao Okazaki**, Mito; **Naoki Saito**, Tokai, all of (JP)

\* cited by examiner

*Primary Examiner*—Antoine Duval Davis  
(74) *Attorney, Agent, or Firm*—Antonelli, Terry, Stout & Kraus, LLP

(73) Assignee: **Hitachi, Ltd.**, Tokyo (JP)

(\*\*) Term: **14 Years**

(21) Appl. No.: **29/128,145**

(22) Filed: **Aug. 21, 2000**

(30) **Foreign Application Priority Data**

Feb. 22, 2000 (JP) ..... 12-007465

(51) **LOC (7) Cl.** ..... **10-04**

(52) **U.S. Cl.** ..... **D10/96; D10/50**

(58) **Field of Search** ..... D10/49, 50, 96;  
73/118.2, 202, 204.18, 204.25, 204.11,  
202.5; 123/494; 701/103

(56) **References Cited**

**U.S. PATENT DOCUMENTS**

6,018,994 \* 2/2000 Yonezawa et al. .... 73/118.2 X

(57) **CLAIM**

The ornamental design for an air flow senser for motorcar, as shown.

**DESCRIPTION**

FIG. 1 is a front, top and left side elevational perspective view of a air flow senser for motorcar showing our new design;

FIG. 2 is a front elevational view thereof;

FIG. 3 is a right side elevational view thereof;

FIG. 4 is a top plan view thereof;

FIG. 5 is a bottom plan view thereof;

FIG. 6 is a rear elevational view thereof; and,

FIG. 7 is a left side elevational view thereof.

**1 Claim, 4 Drawing Sheets**

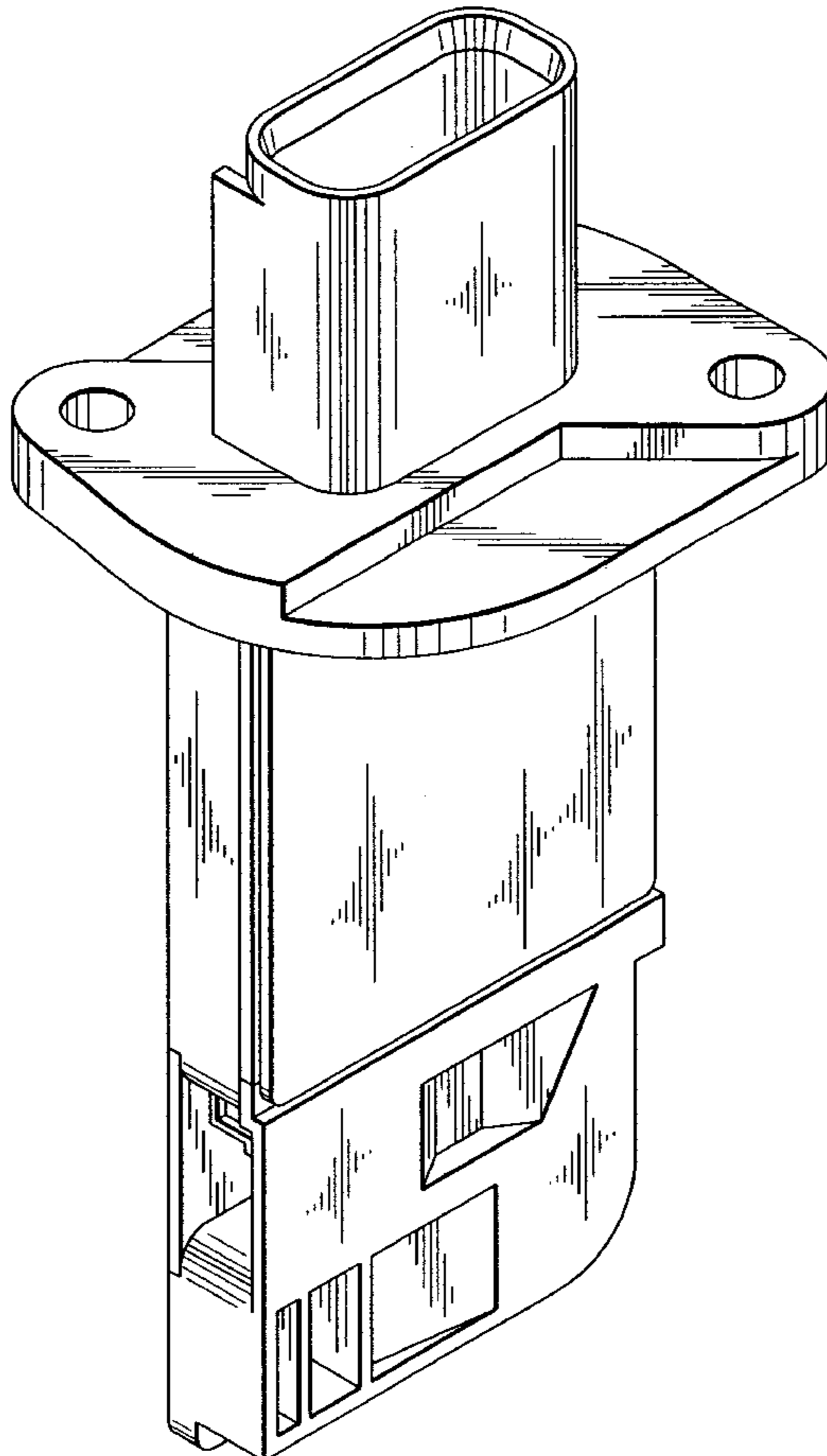

*FIG. 1*

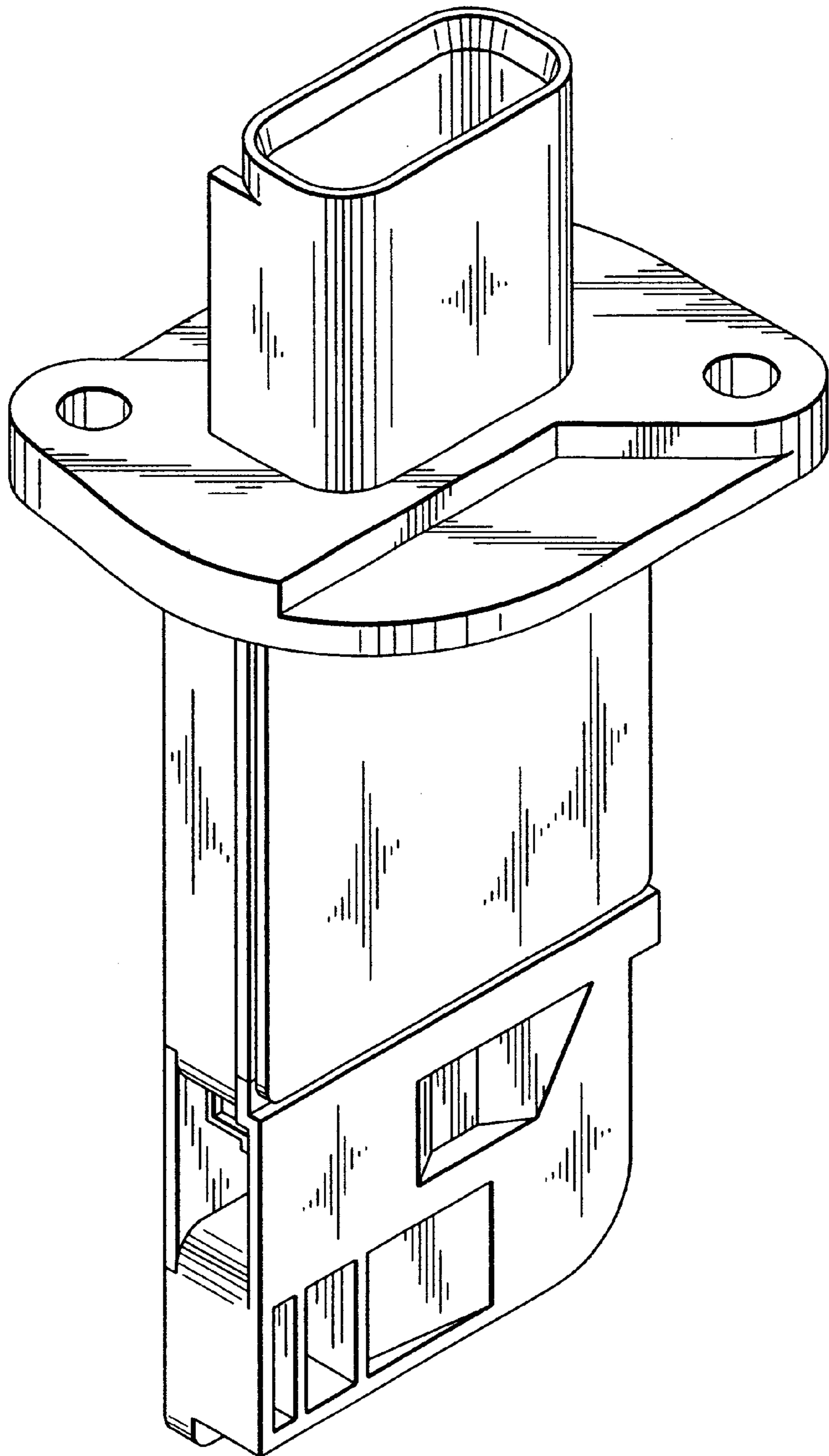

*FIG. 2*

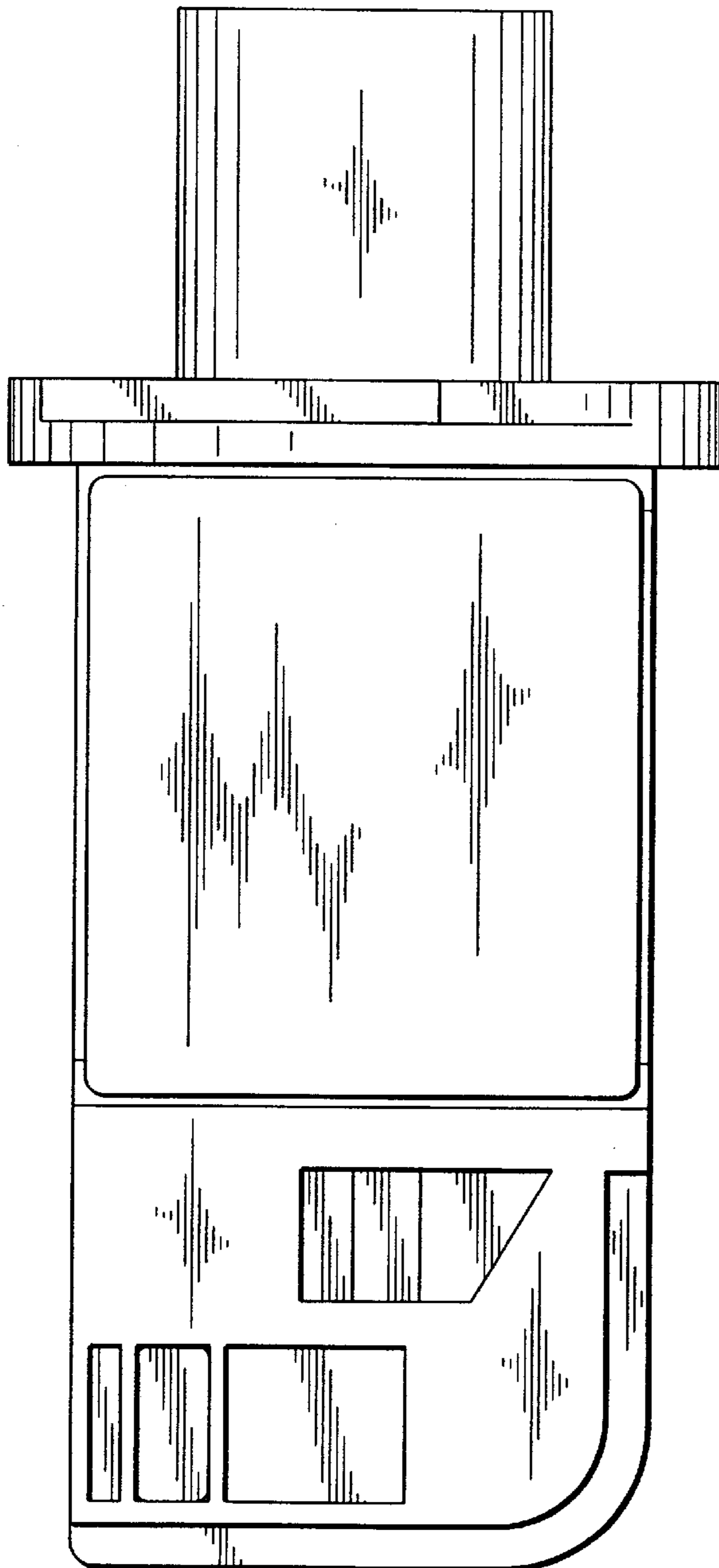

*FIG. 3*

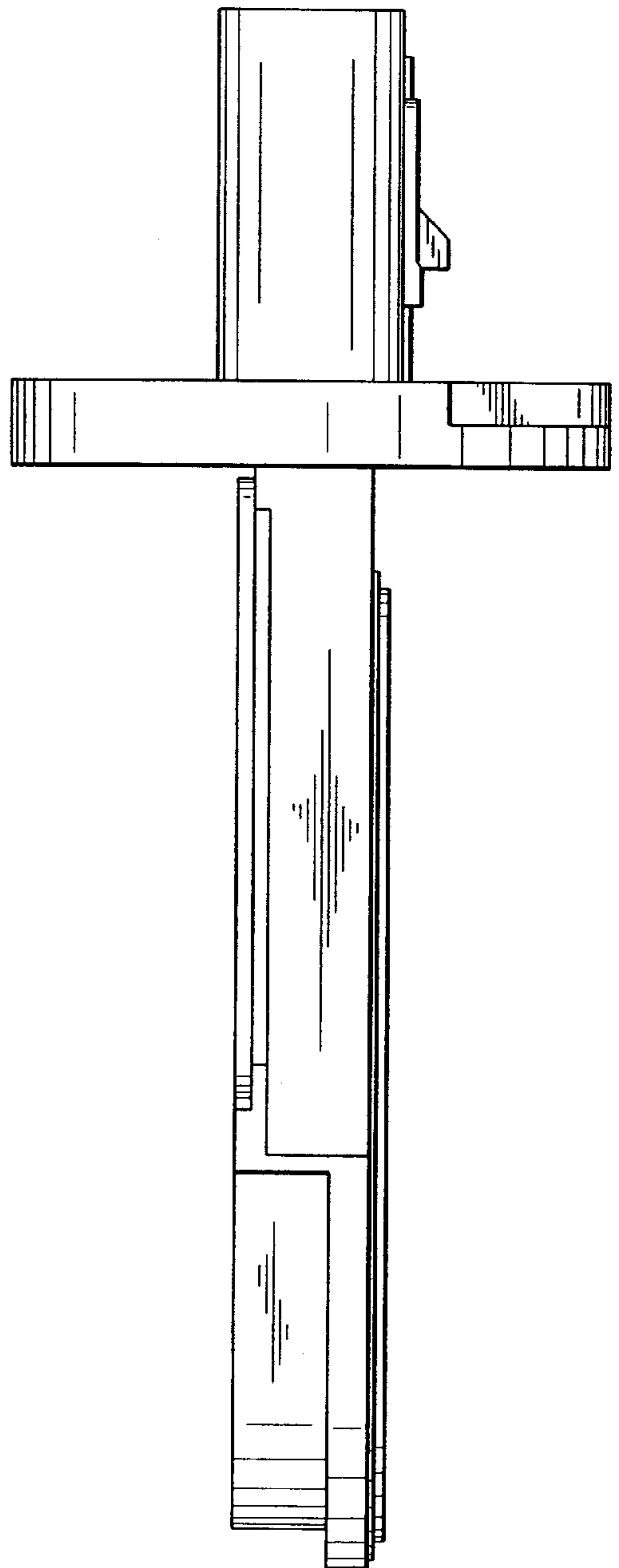

**FIG. 4**

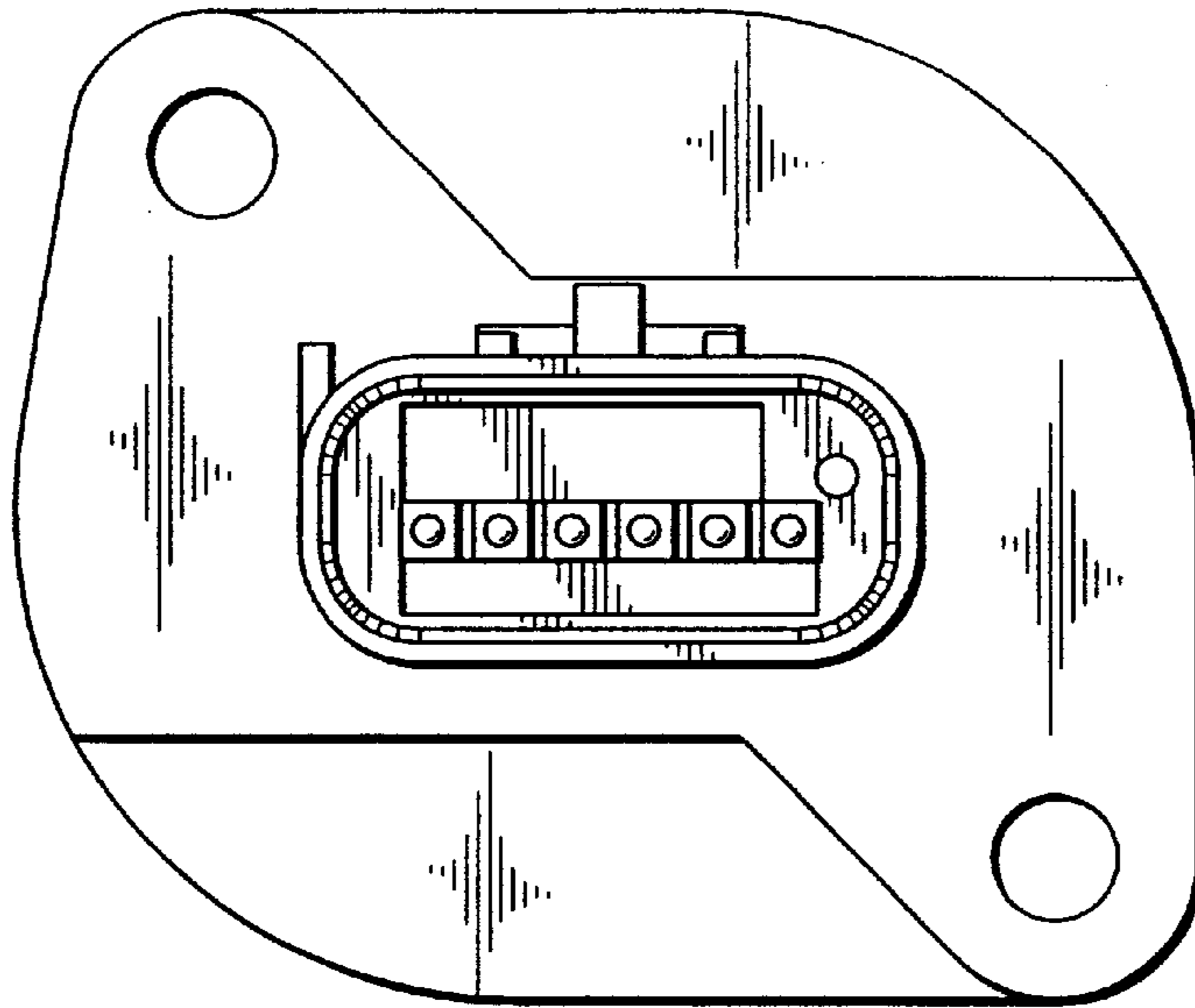

**FIG. 5**

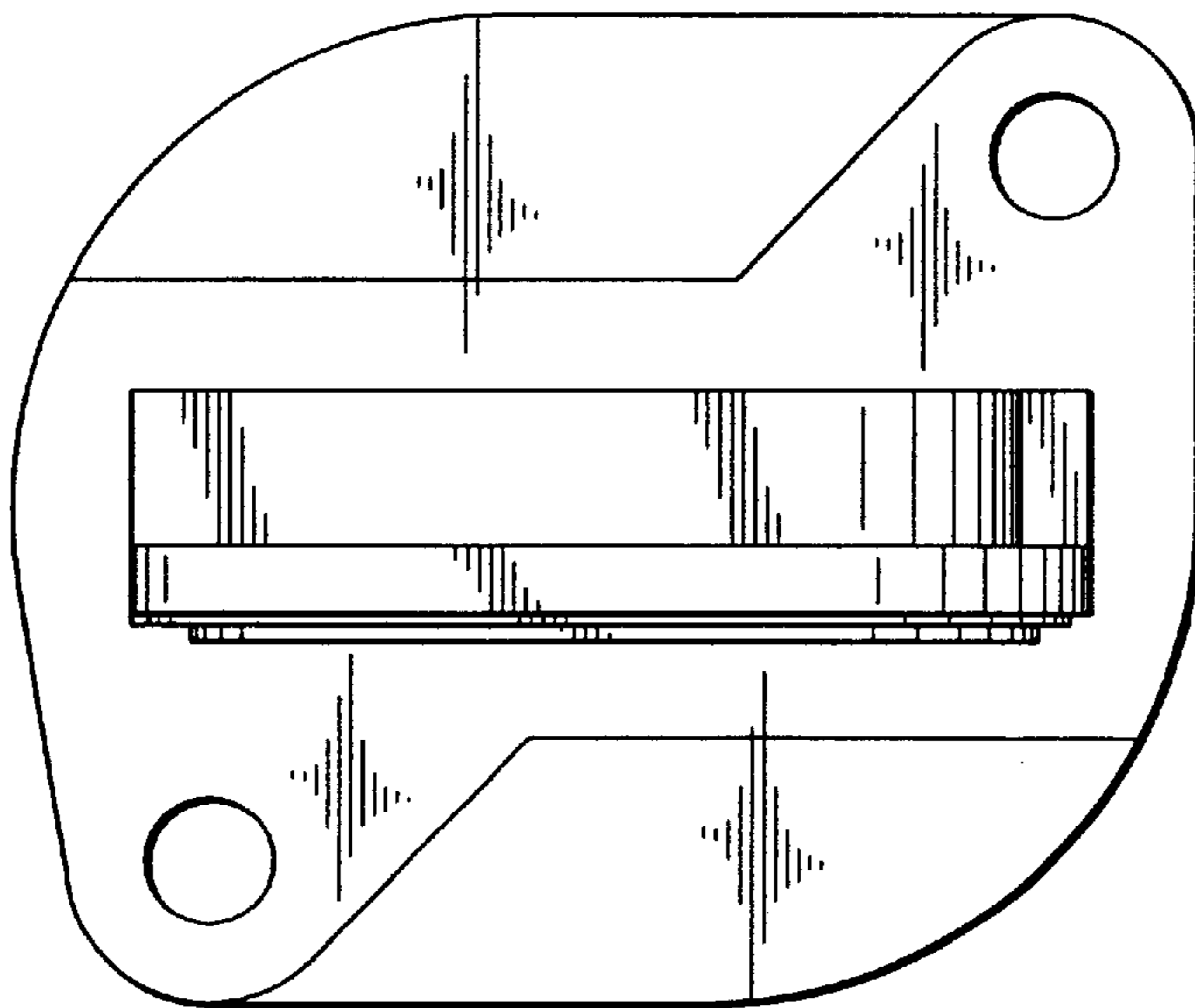

*FIG. 6*

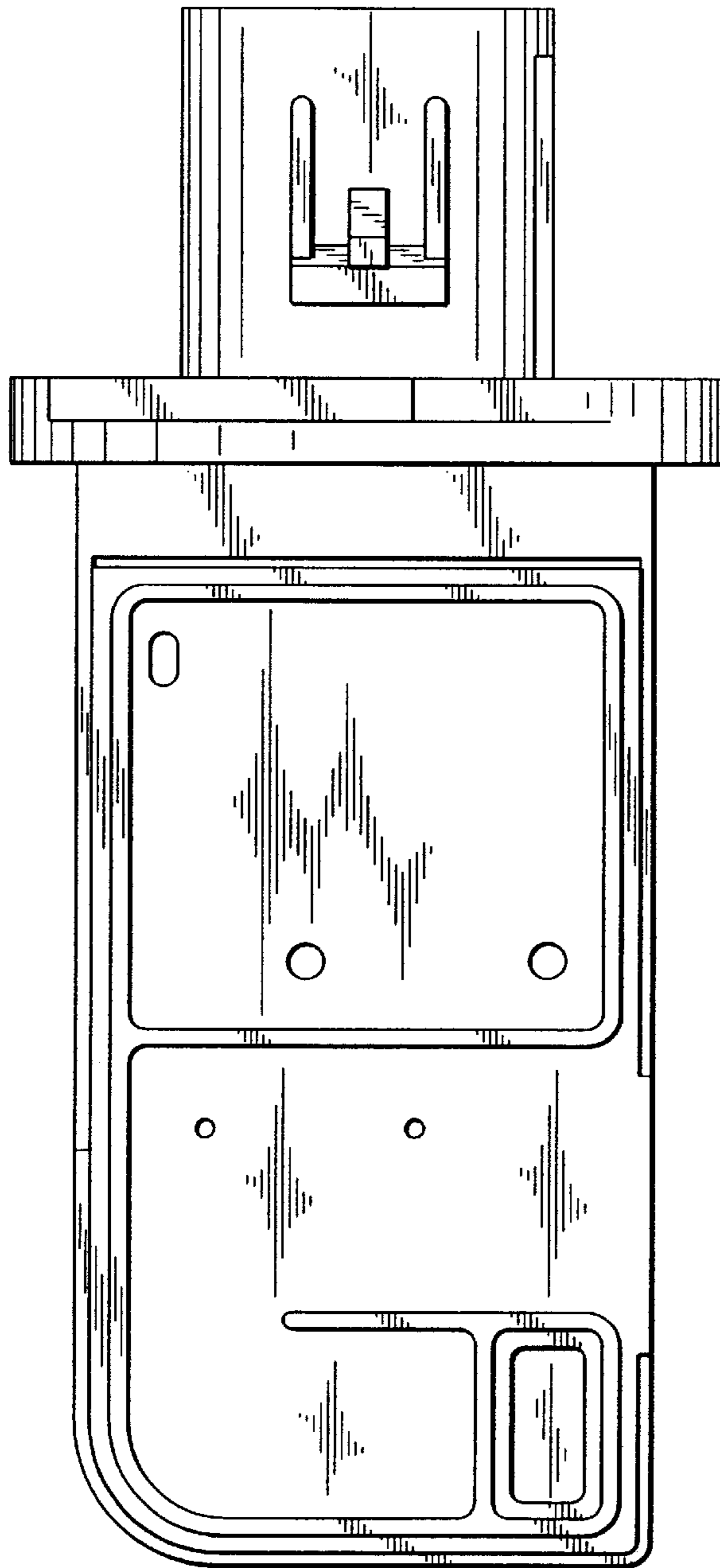

*FIG. 7*

