



US00D447882B1

(12) **United States Design Patent**  
**Kane**

(10) **Patent No.:** **US D447,882 S**

(45) **Date of Patent:** **\*\* Sep. 18, 2001**

(54) **SEAT**

(75) **Inventor:** **Brian J. Kane**, San Francisco, CA (US)

(73) **Assignee:** **Landscape Forms, Inc.**, Kalamazoo, MI (US)

(\*\*) **Term:** **14 Years**

(21) **Appl. No.:** **29/116,726**

(22) **Filed:** **Jan. 10, 2000**

(51) **LOC (7) Cl.** ..... **06-01**

(52) **U.S. Cl.** ..... **D6/375; D6/370; D6/379; D6/381**

(58) **Field of Search** ..... D6/334, 335, 348, D6/360, 368, 369, 370, 373, 374, 375, 376, 379, 380, 381, 499, 500, 501, 502; 297/232, 445.1, 446.1, 448.1, 452.63, 452.64

(56) **References Cited**

**U.S. PATENT DOCUMENTS**

D. 211,171	*	5/1968	Blier	.....	D6/379
D. 235,495	*	6/1975	Laylon	.....	D6/374
D. 236,047	*	7/1975	Hoshall	.....	D6/379
D. 236,394	*	8/1975	Hoshall	.....	D6/379
D. 333,042	*	2/1993	Komai et al.	.....	D6/370
D. 339,247	*	9/1993	Grosfillex	.....	D6/334
D. 341,728	*	11/1993	Grosfillex	.....	D6/334
D. 345,869	*	4/1994	Grosfillex	.....	D6/334
D. 436,748	*	1/2001	Noll	.....	D6/370
6,199,950	*	3/2001	Noll	.....	297/452.63

**OTHER PUBLICATIONS**

Chair and chair units identified as 66501, 66532, 66401-TE66400/66401-TE and 66501/66400/66532-TE in Fixtures Furniture Price List Workbook, p. 87, Jan. 1991.\*  
Chair illustrated in Wabash Valley catalog, p. 56, 1998.\*

Chair illustrated in Brown Jordan catalog, p. 2, 1986.\*  
Sweet's General Building & Renovation Catalog, BuyLine 5466, TimberForm Site Complements, Columbia Cascade 1975 S.W. Fifth Avenue, Portland, OR 97201, 1996 (3 pp.).  
Manhattan Side Chair, Metro, 1987 (1 pg.).

\* cited by examiner

*Primary Examiner*—Doris V. Coles

*Assistant Examiner*—Elizabeth A. Albert

(74) *Attorney, Agent, or Firm*—Heslin Rothenberg Farley & Mesiti P.C.

(57) **CLAIM**

The ornamental design for a seat, as shown and described.

**DESCRIPTION**

This application is related to commonly owned, concurrently filed applications Ser. No. 29/116,725 and Ser. No. 29/116,727.

FIG. 1 is an isometric view of the seat of my new design;

FIG. 2 is a top plan view thereof;

FIG. 3 is a front elevational view thereof;

FIG. 4 is a back elevational view thereof;

FIG. 5 is a left side elevational view thereof;

FIG. 6 is a right side elevational view thereof;

FIG. 7 is an isometric view of a first embodiment of the seat of my design;

FIG. 8 is an isometric view of a second embodiment of the seat of my design;

FIG. 9 is a back elevational view of the second embodiment; and,

FIG. 10 is an isometric view of a fourth embodiment of the seat of my new design.

The broken line showing in the drawing figures is for illustrative purposes only and forms no part of the claimed design.

**1 Claim, 7 Drawing Sheets**

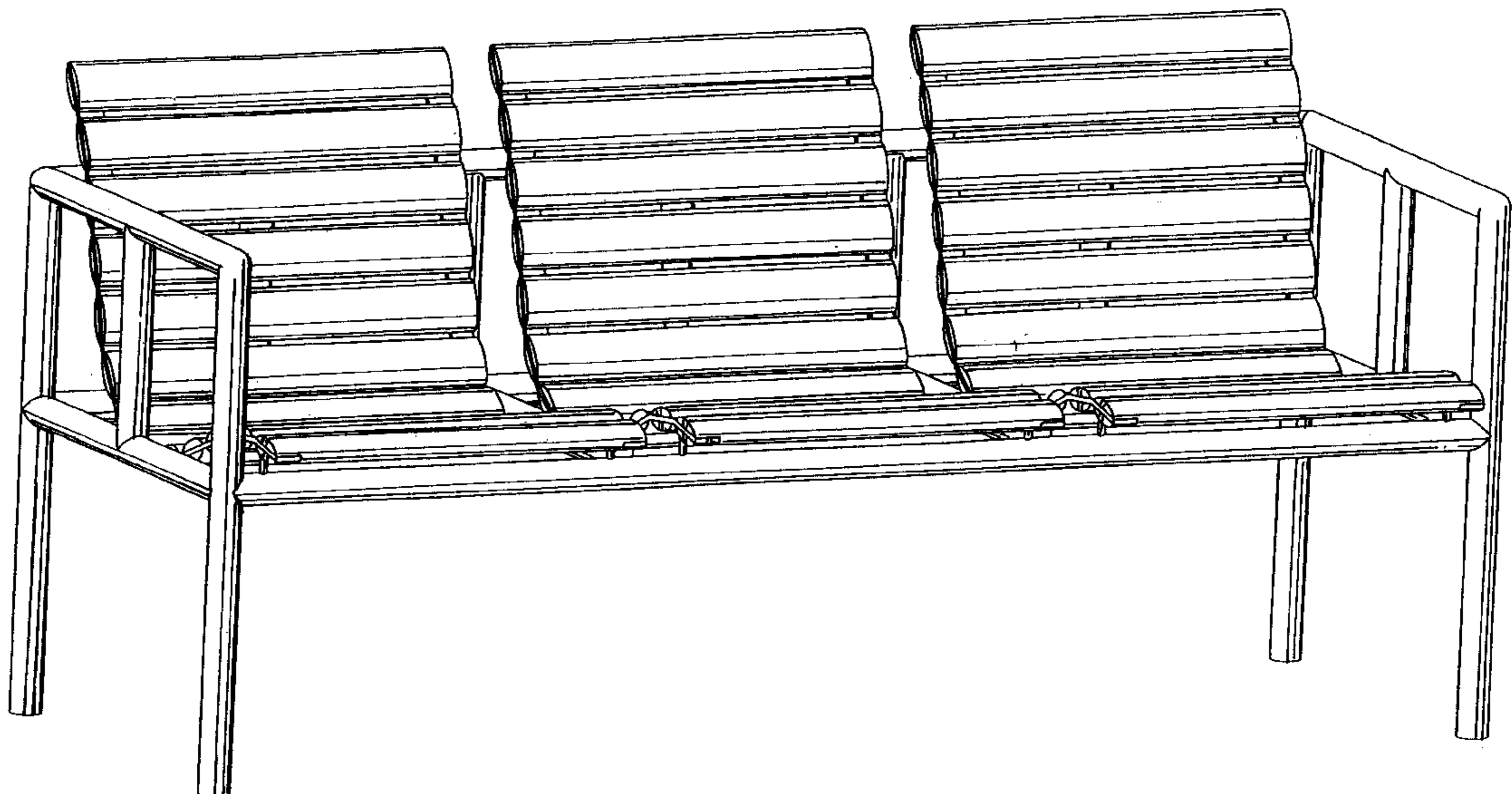

FIG. 2

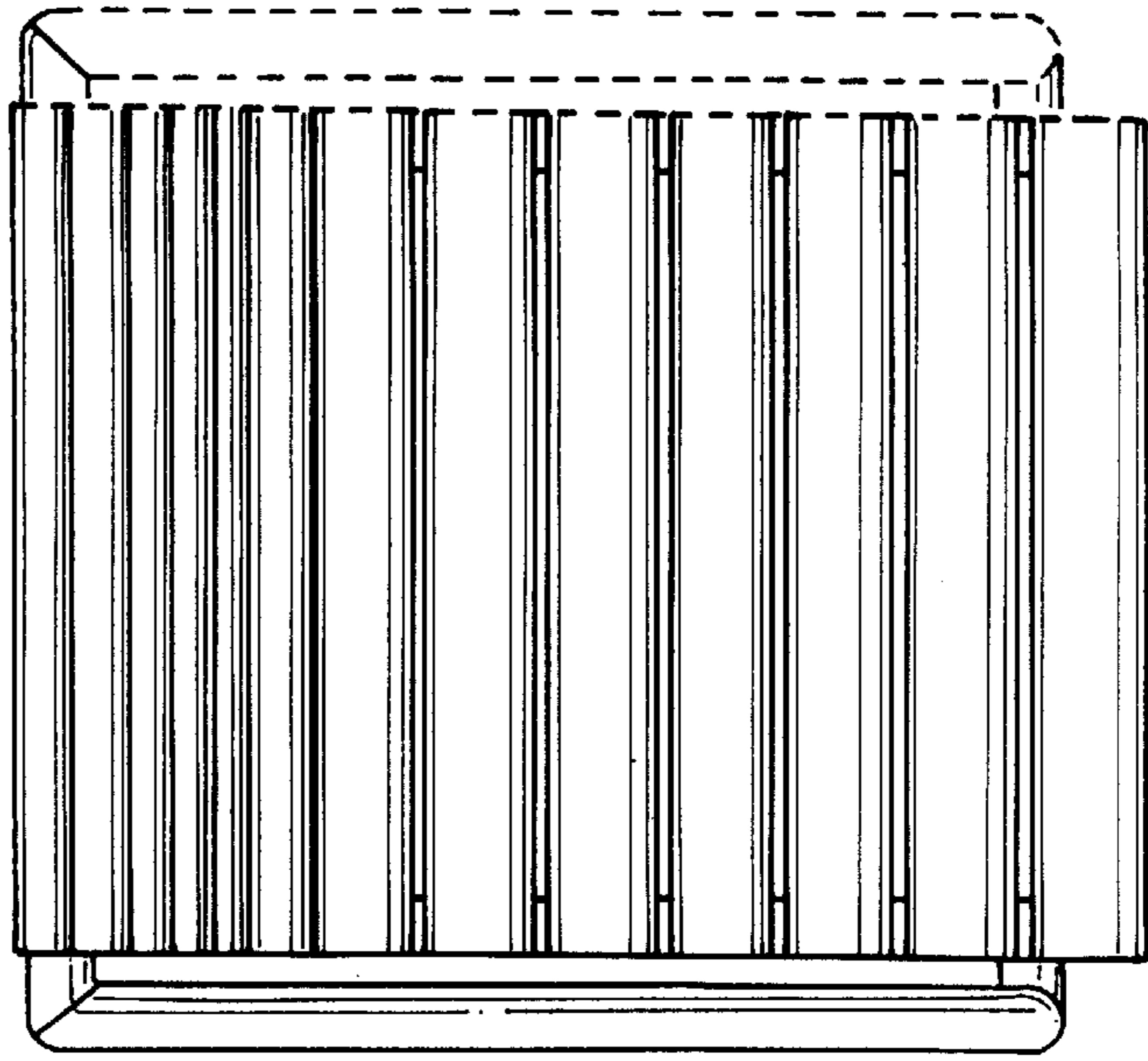

FIG. 1

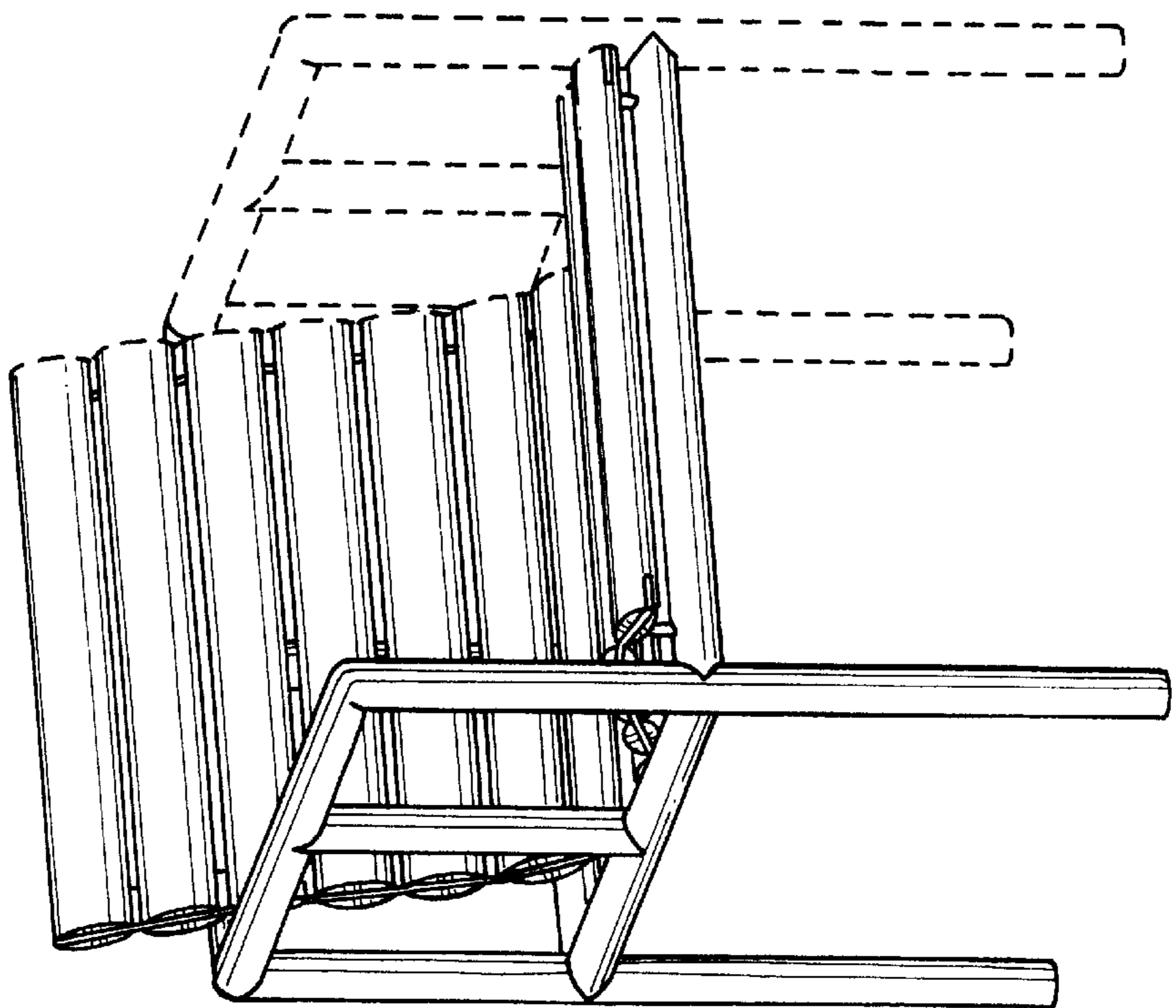

FIG. 4

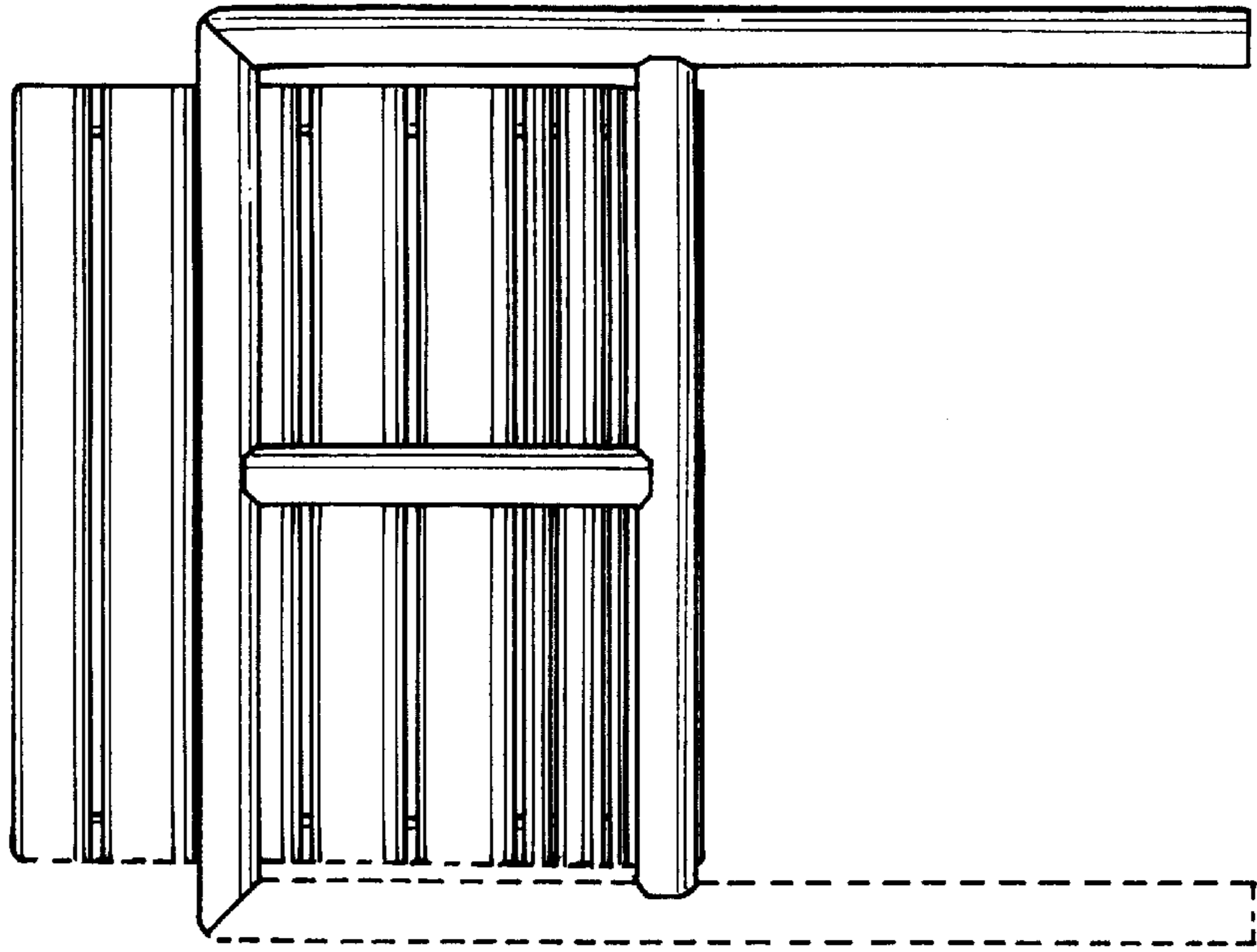
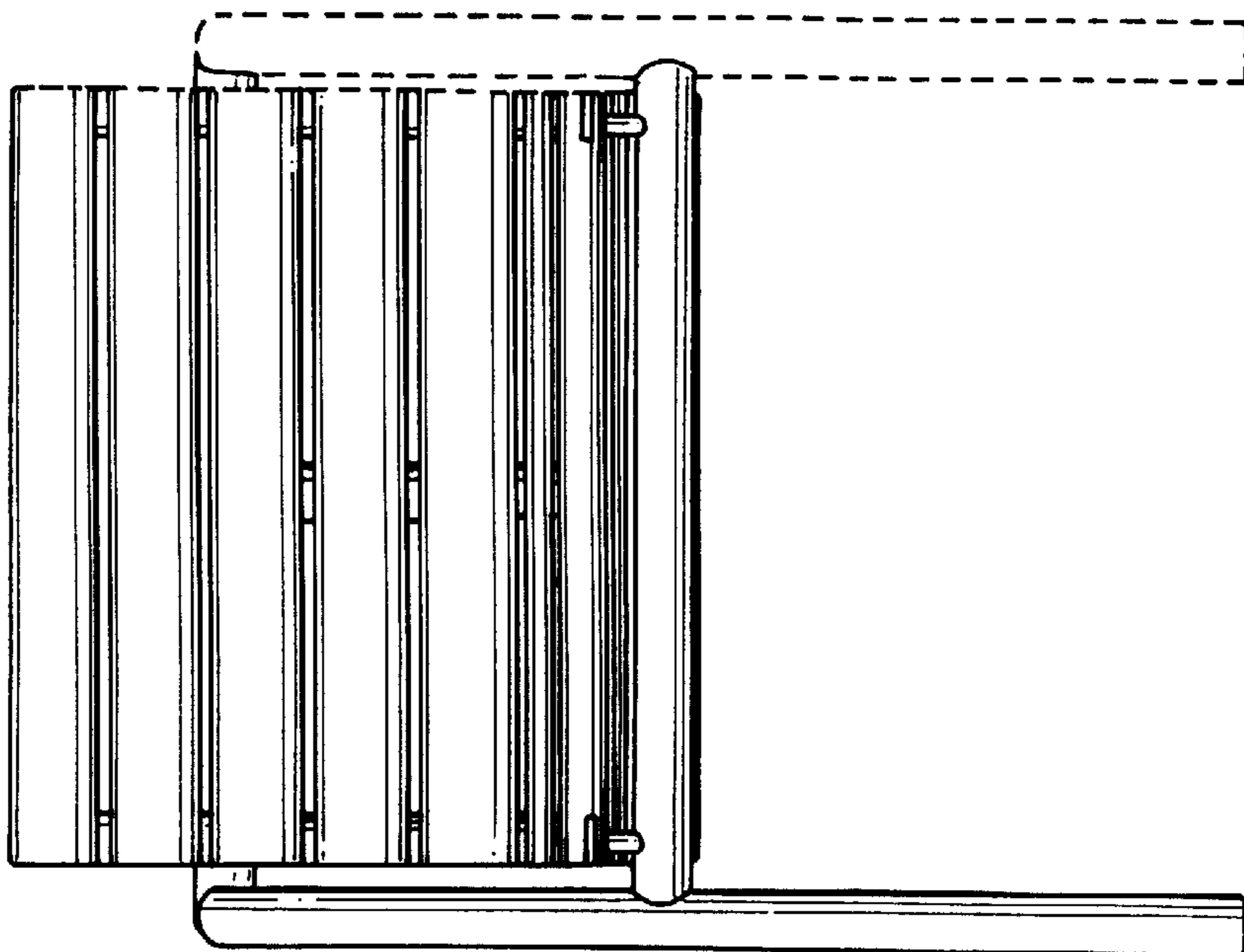

FIG. 3



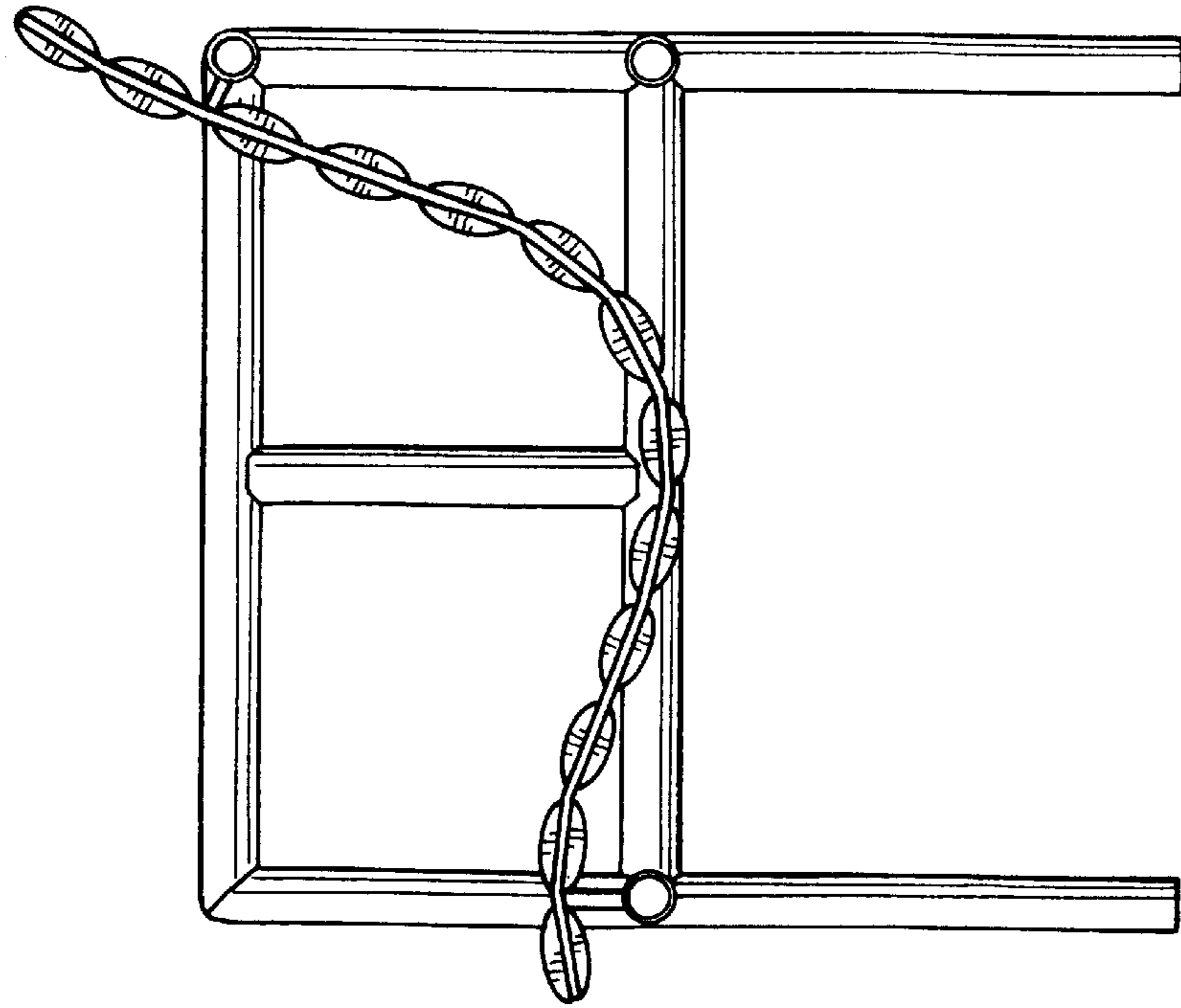

FIG. 6

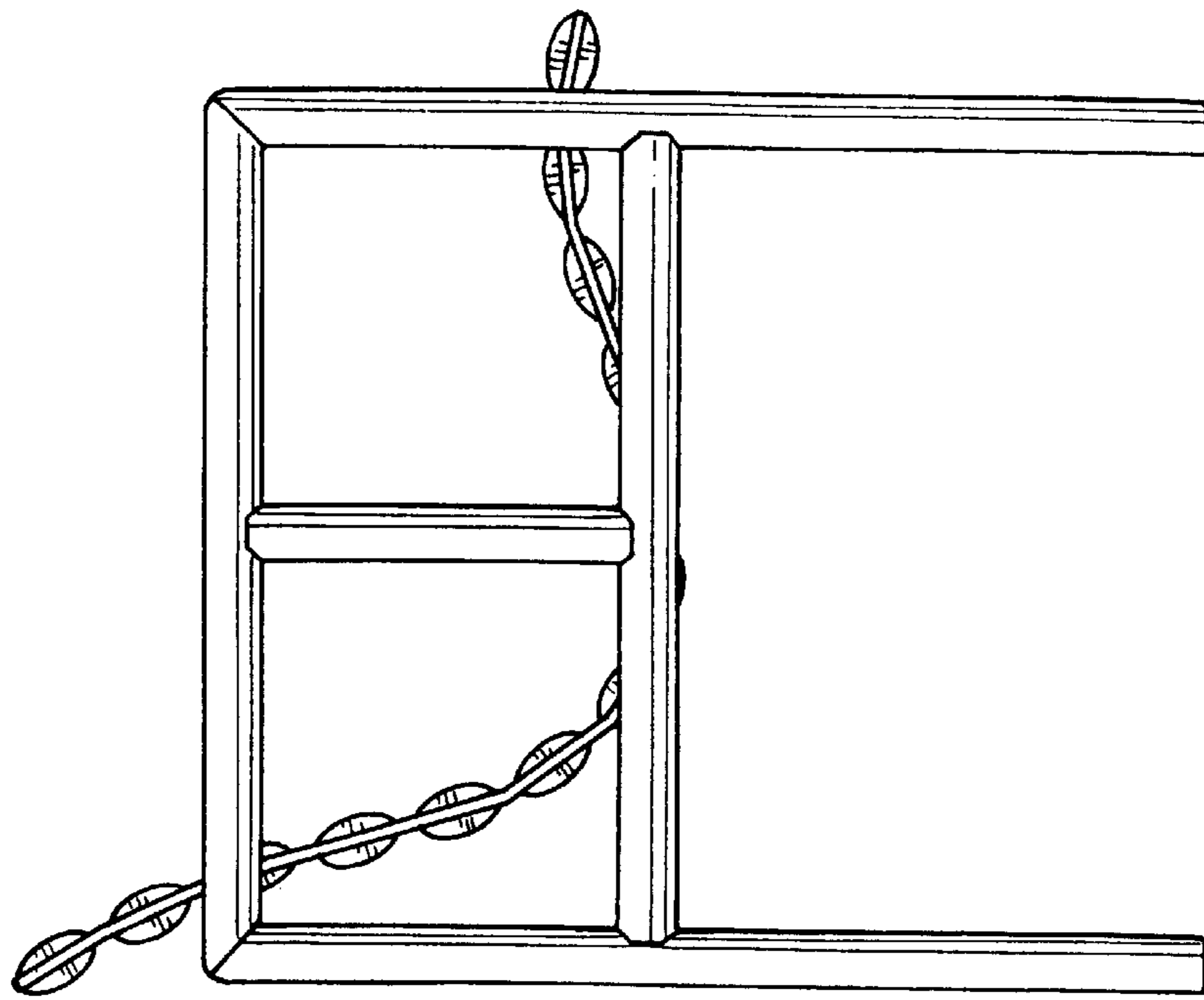

FIG. 5

FIG. 7

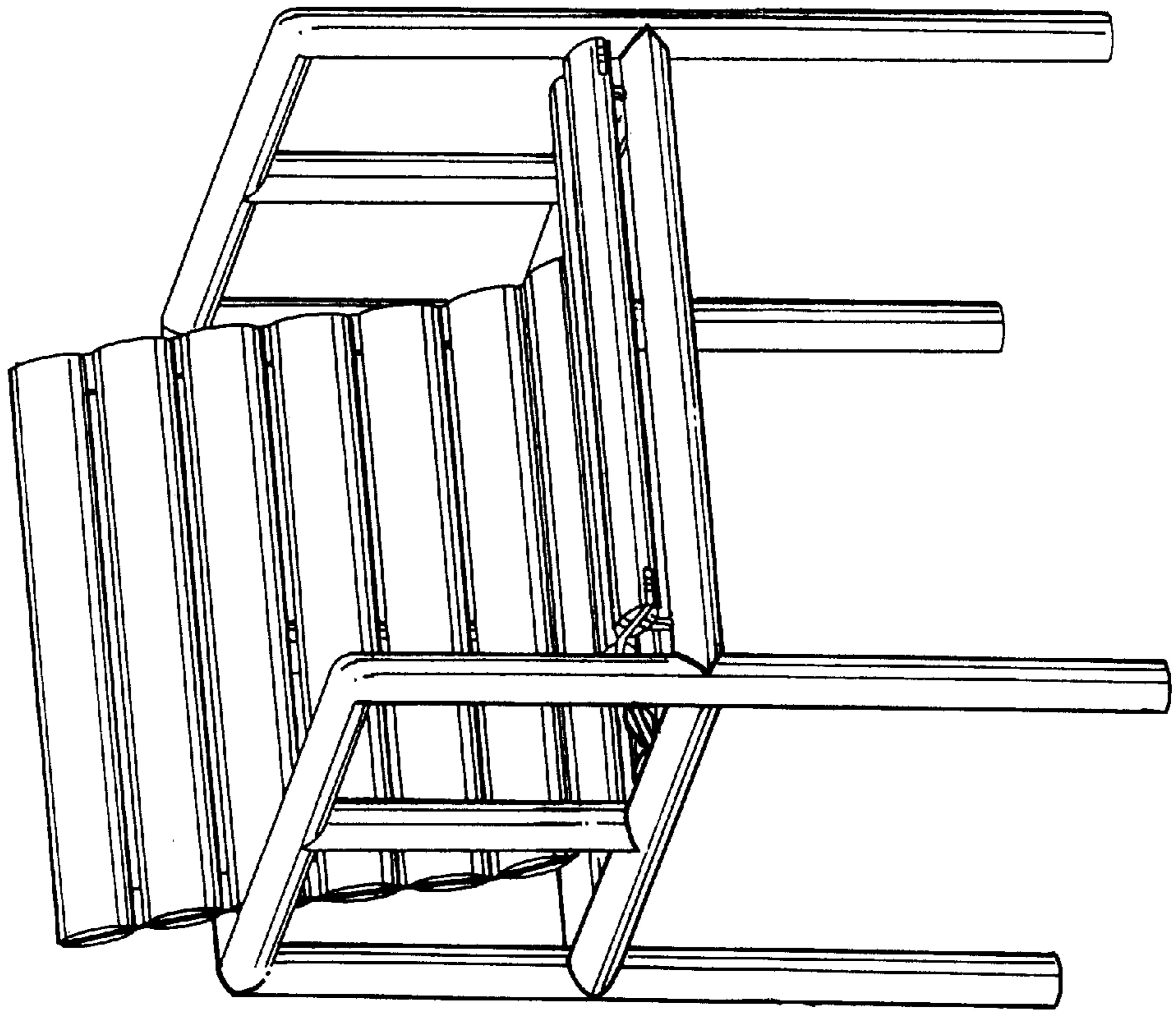



FIG. 8

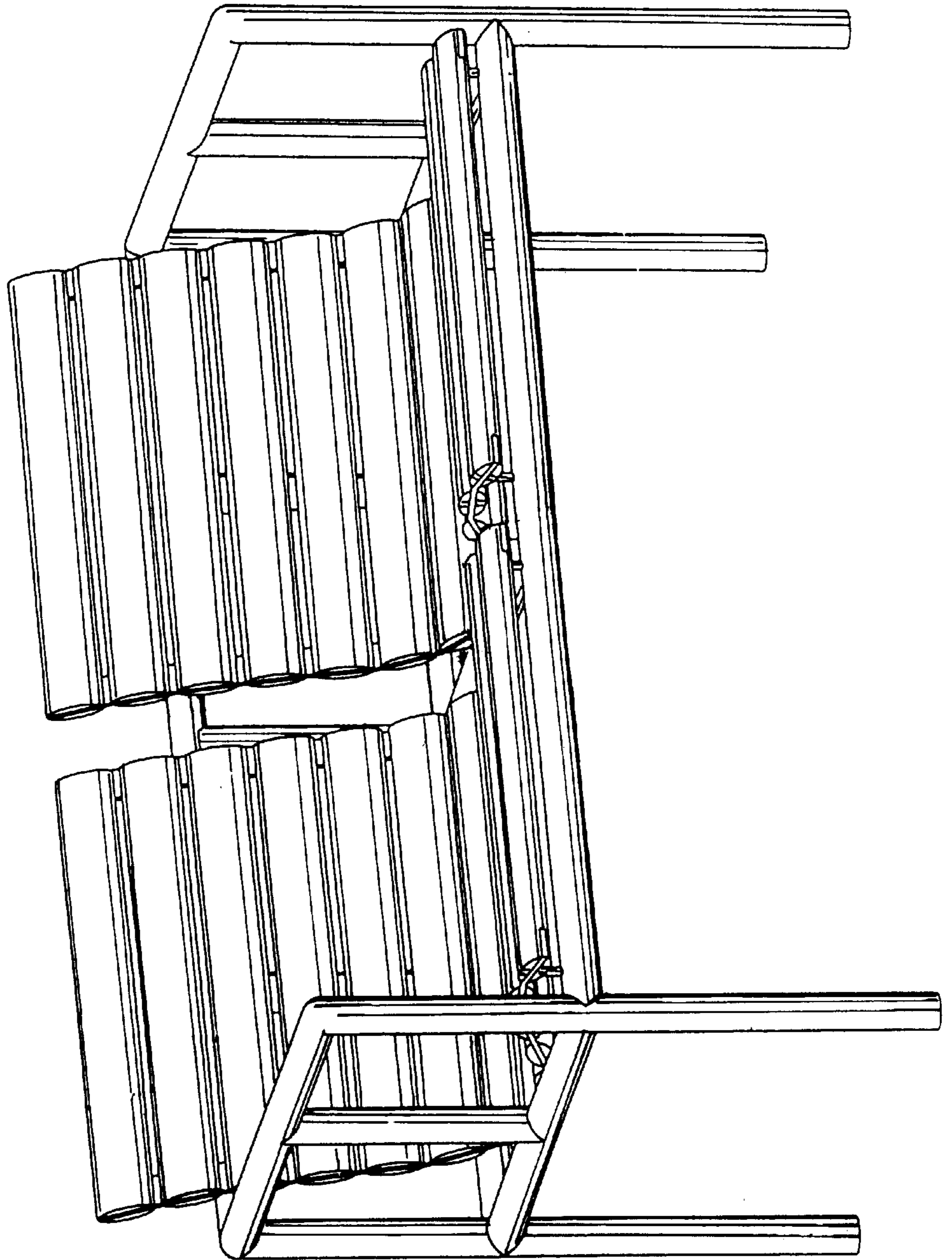
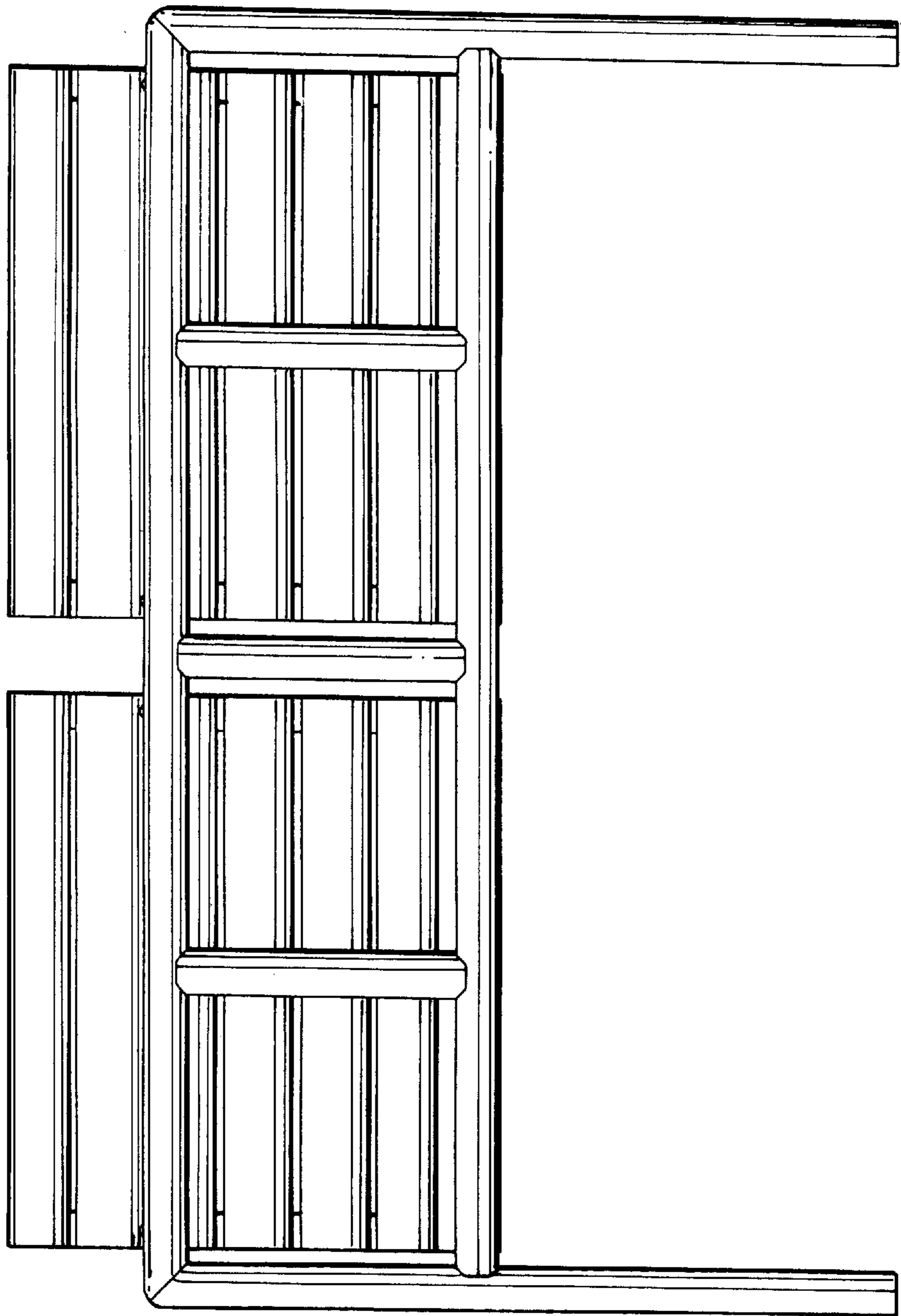

FIG. 9



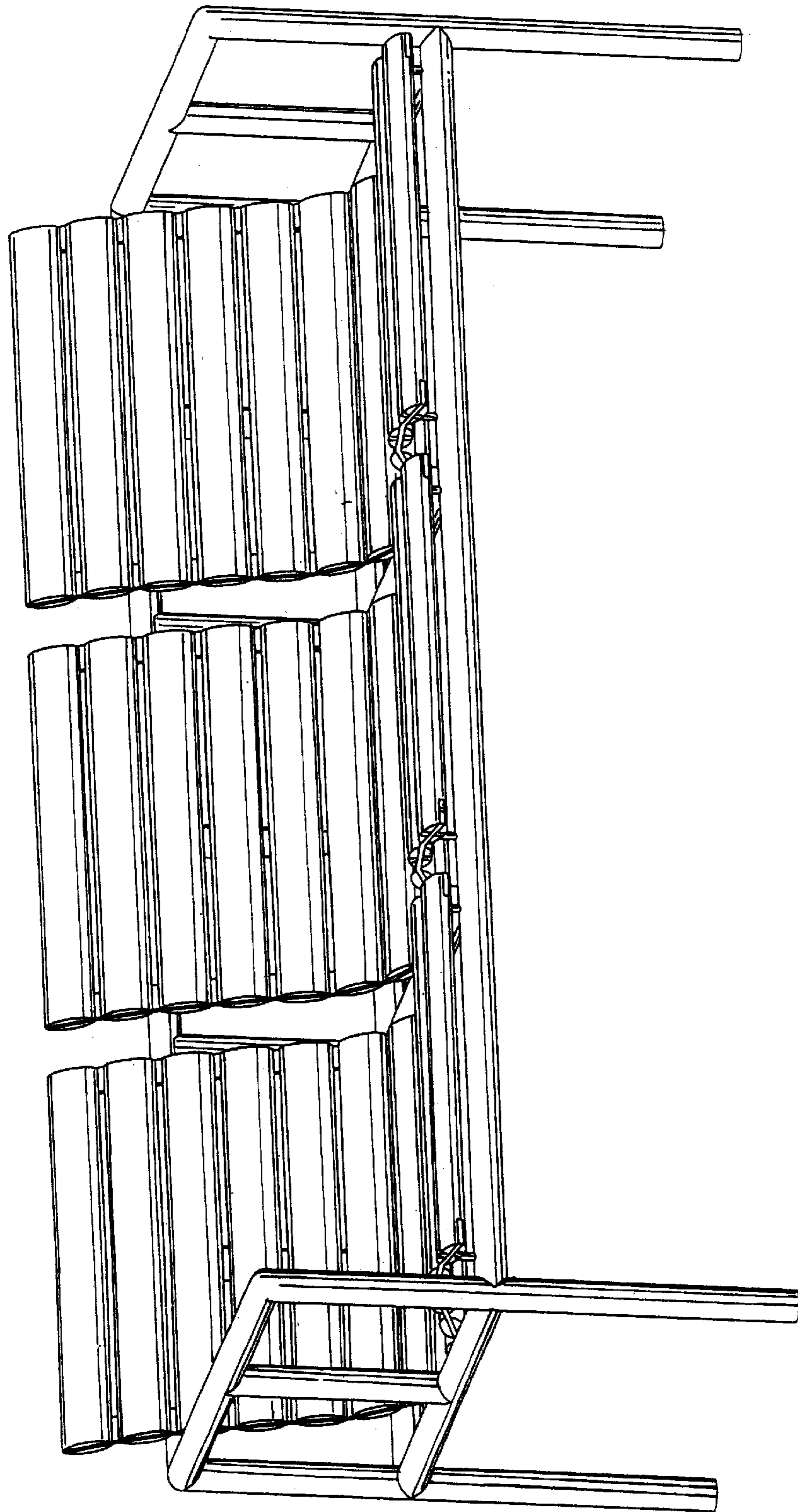

FIG. 10