



US00D447737B1

(12) **United States Design Patent**
Scherer et al.

(10) **Patent No.:** **US D447,737 S**

(45) **Date of Patent:** **** Sep. 11, 2001**

(54) **RIGHT ANGLE DUAL RACEWAY FITTING**

5,134,250 * 7/1992 Caveney et al. 174/101
5,753,855 * 5/1998 Nicoli et al. 174/49

(75) Inventors: **Craig Scherer, Wilmette; Michael Thuma, Des Plaines, both of IL (US)**

* cited by examiner

(73) Assignee: **Panduit Corp., Tinley Park, IL (US)**

Primary Examiner—Joel Sincavage

(**) Term: **14 Years**

(74) *Attorney, Agent, or Firm*—Mark D. Hilliard; Robert A. McCann; Michael J. Turgeon

(21) Appl. No.: **29/094,631**

(57) **CLAIM**

(22) Filed: **Jun. 4, 1998**

The ornamental design for a right angle dual raceway fitting, as shown and described.

Related U.S. Application Data

DESCRIPTION

(63) Continuation of application No. 29/063,390, filed on Dec. 6, 1996, now Pat. No. Des. 402,262.

FIG. 1 is a front and upper left perspective view of the right angle dual raceway fitting;

(51) **LOC (7) Cl.** **13-03**

FIG. 2 is a front elevational view thereof, the right side elevational view being a mirror image;

(52) **U.S. Cl.** **D13/155**

FIG. 3 is a left side elevational view thereof, the rear elevational view being a mirror image;

(58) **Field of Search** D13/155; 174/48, 174/49, 68.3, 72 C, 95, 101; 138/92, 155, 156, 162; 52/220.7, 287.1

FIG. 4 is a top plan view thereof;

FIG. 5 is a bottom plan view thereof;

(56) **References Cited**

FIG. 6 is an exploded front and upper left perspective view thereof;

U.S. PATENT DOCUMENTS

- D. 181,736 * 12/1957 Cataldo D13/155
- 4,589,449 * 5/1986 Bramwell 138/162
- 4,602,124 * 7/1986 Santucci 174/101
- 4,875,871 * 10/1989 Booty, Sr. et al. 174/72 C X
- 4,951,716 * 8/1990 Tsunoda et al. 138/162
- 4,990,722 * 2/1991 Benito Navazo 174/101 X

FIG. 7 is a fragmentary detail end view of the ornamental grooved portion of the right sidewall of the raceway fitting, the corresponding portion of left sidewall being a mirror image; and,

FIG. 8 is a fragmentary detail end view of the ornamental, central grooved portion of the raceway top wall.

1 Claim, 5 Drawing Sheets

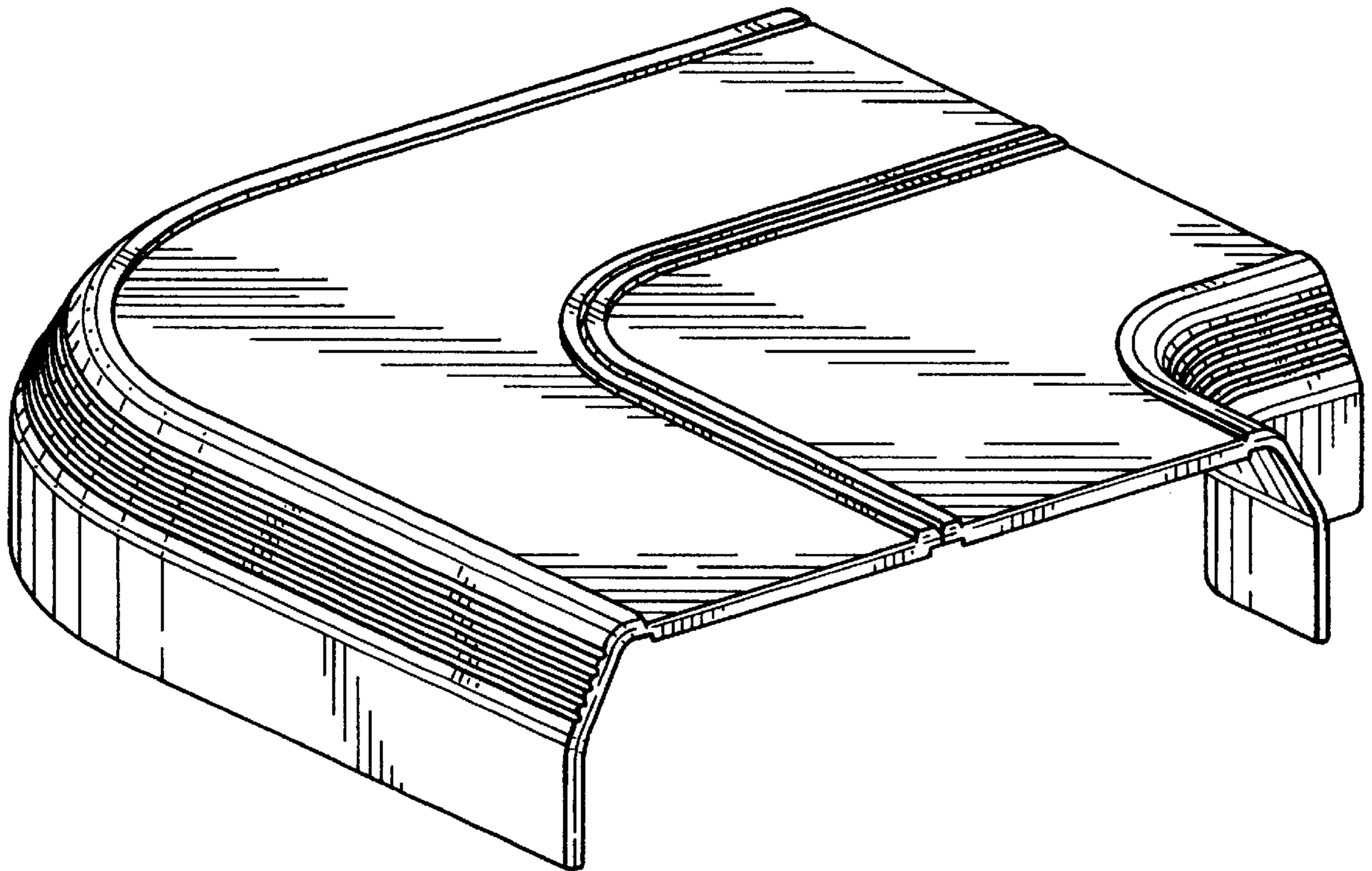

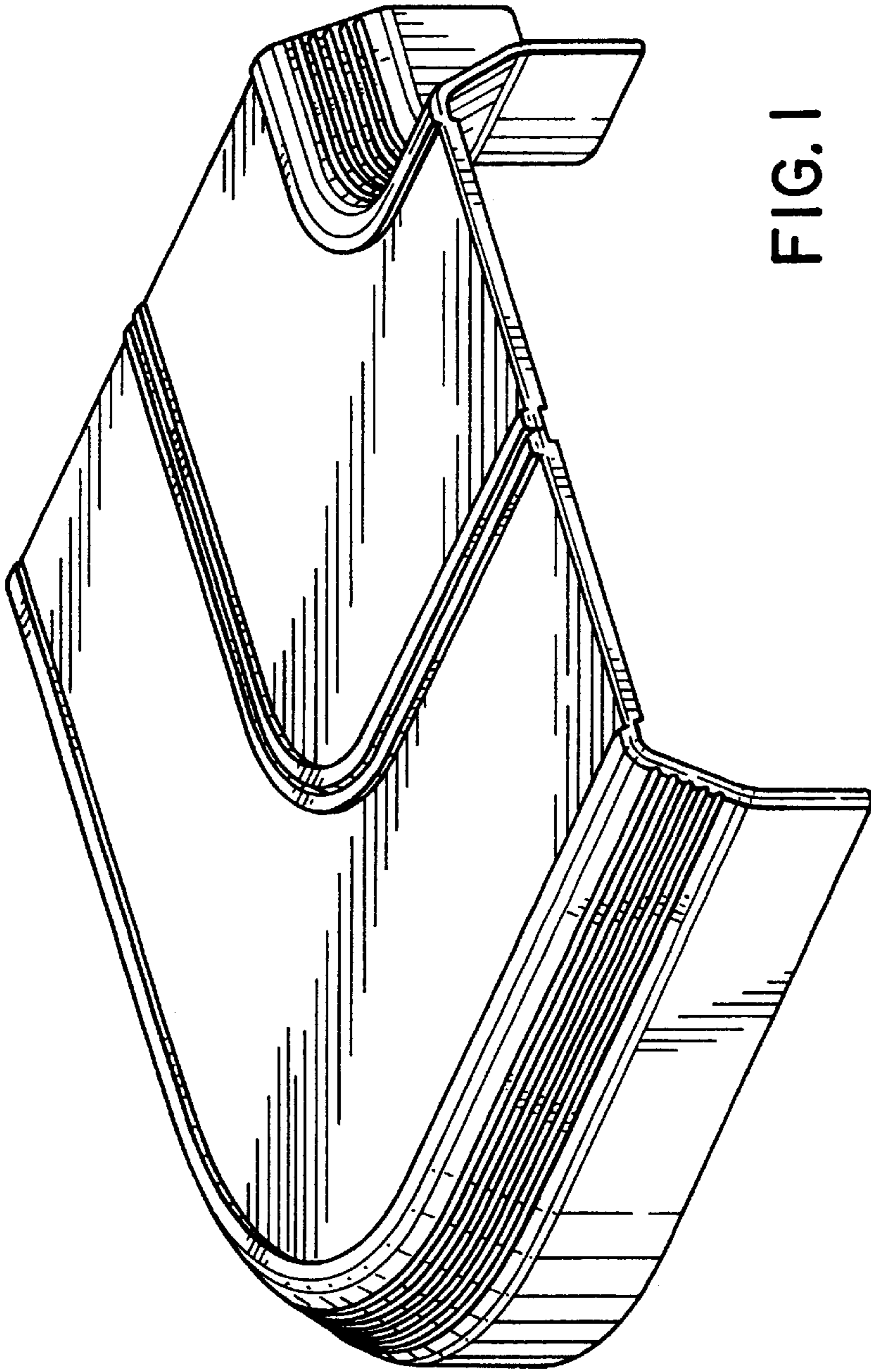

FIG. 1

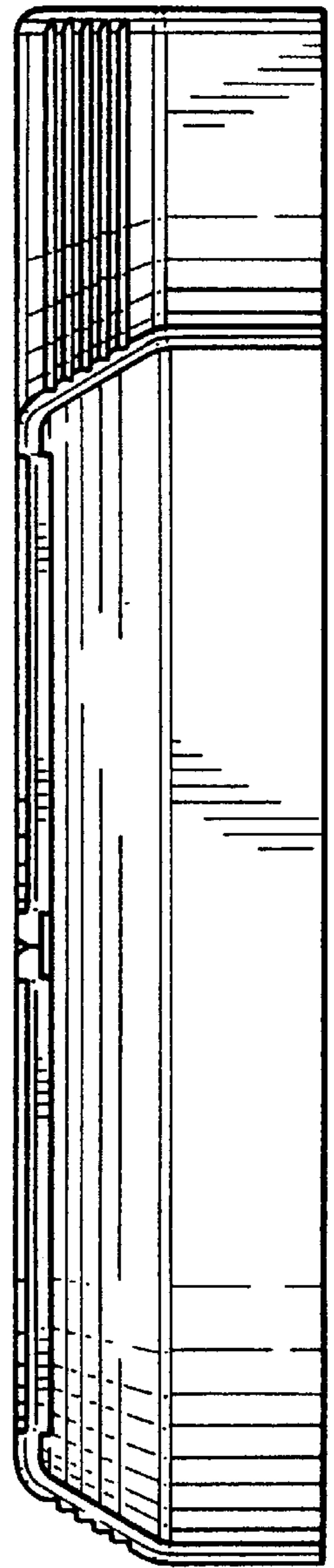

FIG. 2

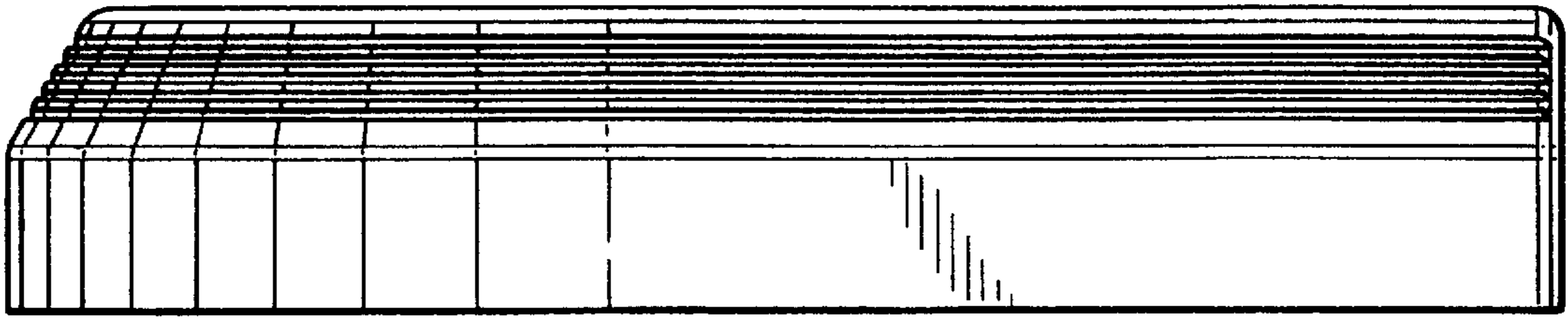

FIG. 3

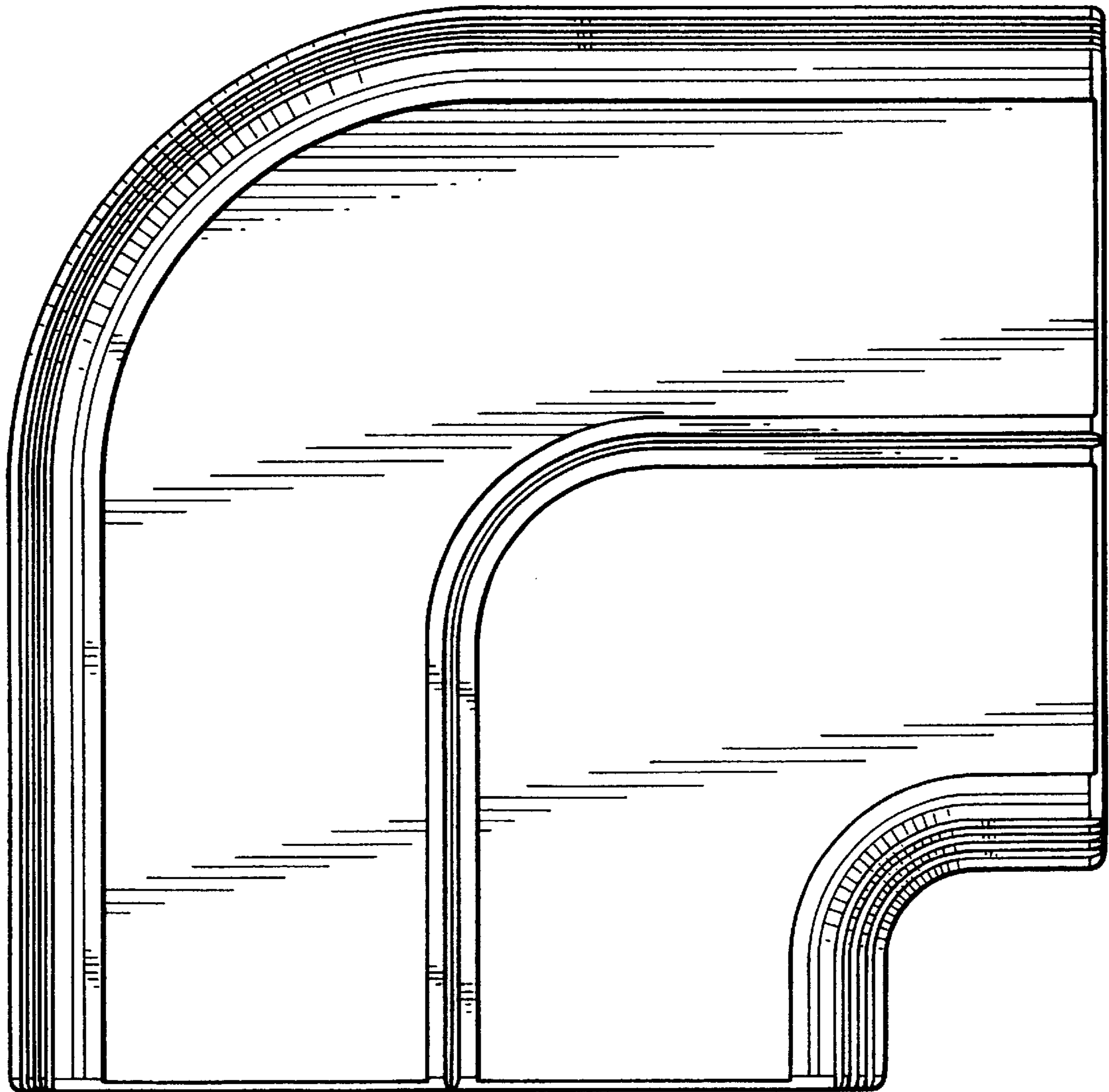

FIG. 4

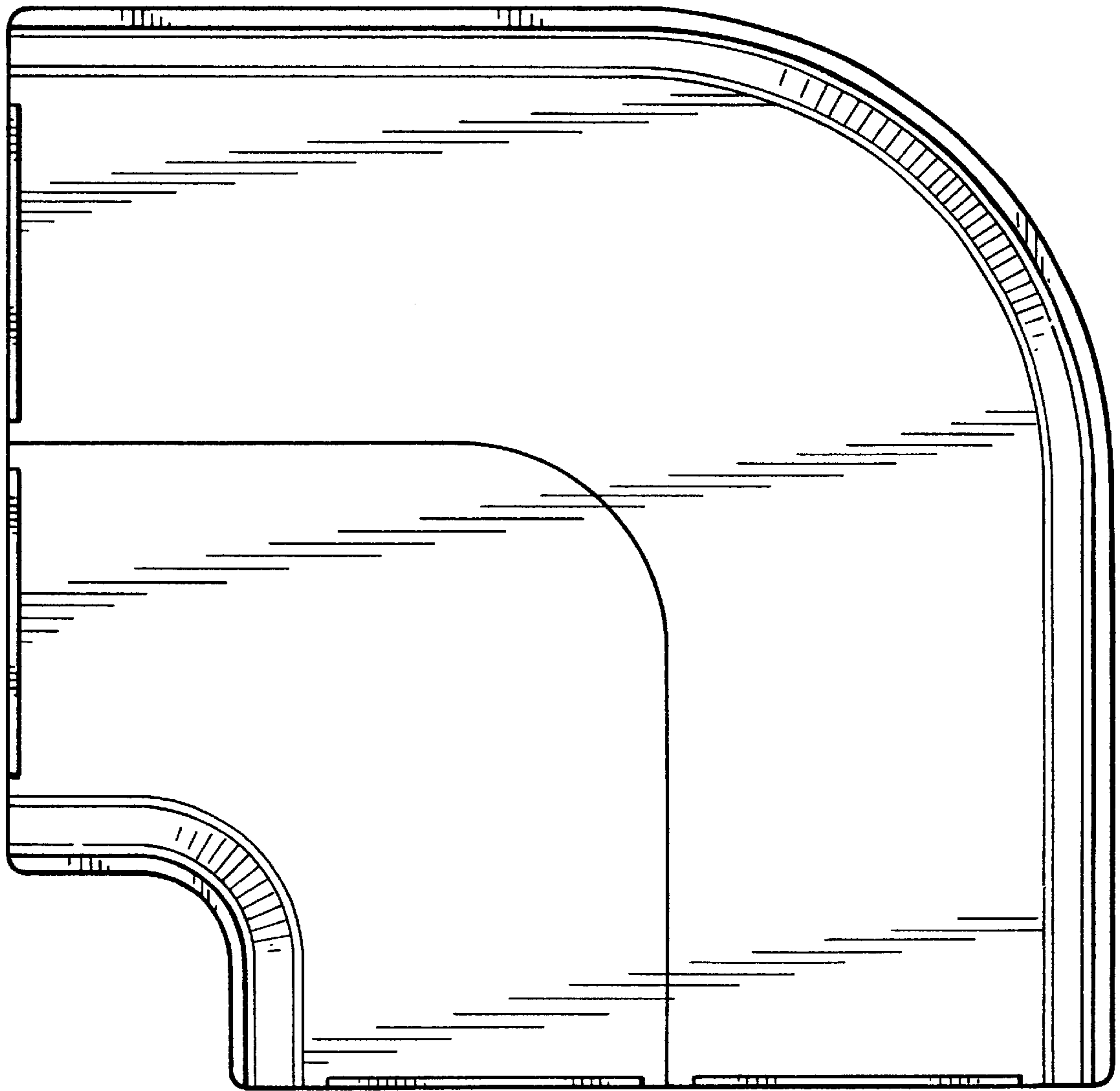

FIG. 5

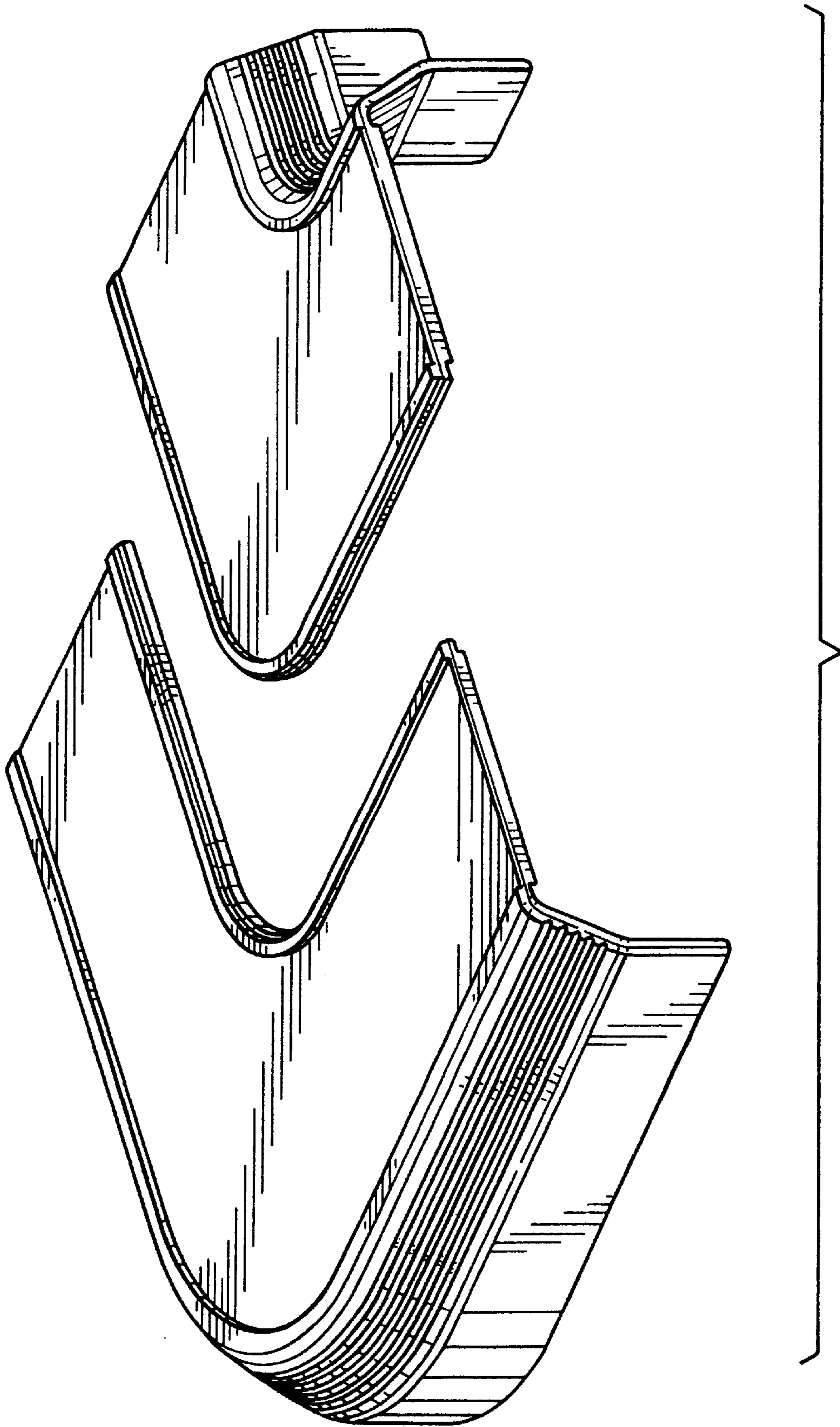

FIG. 6

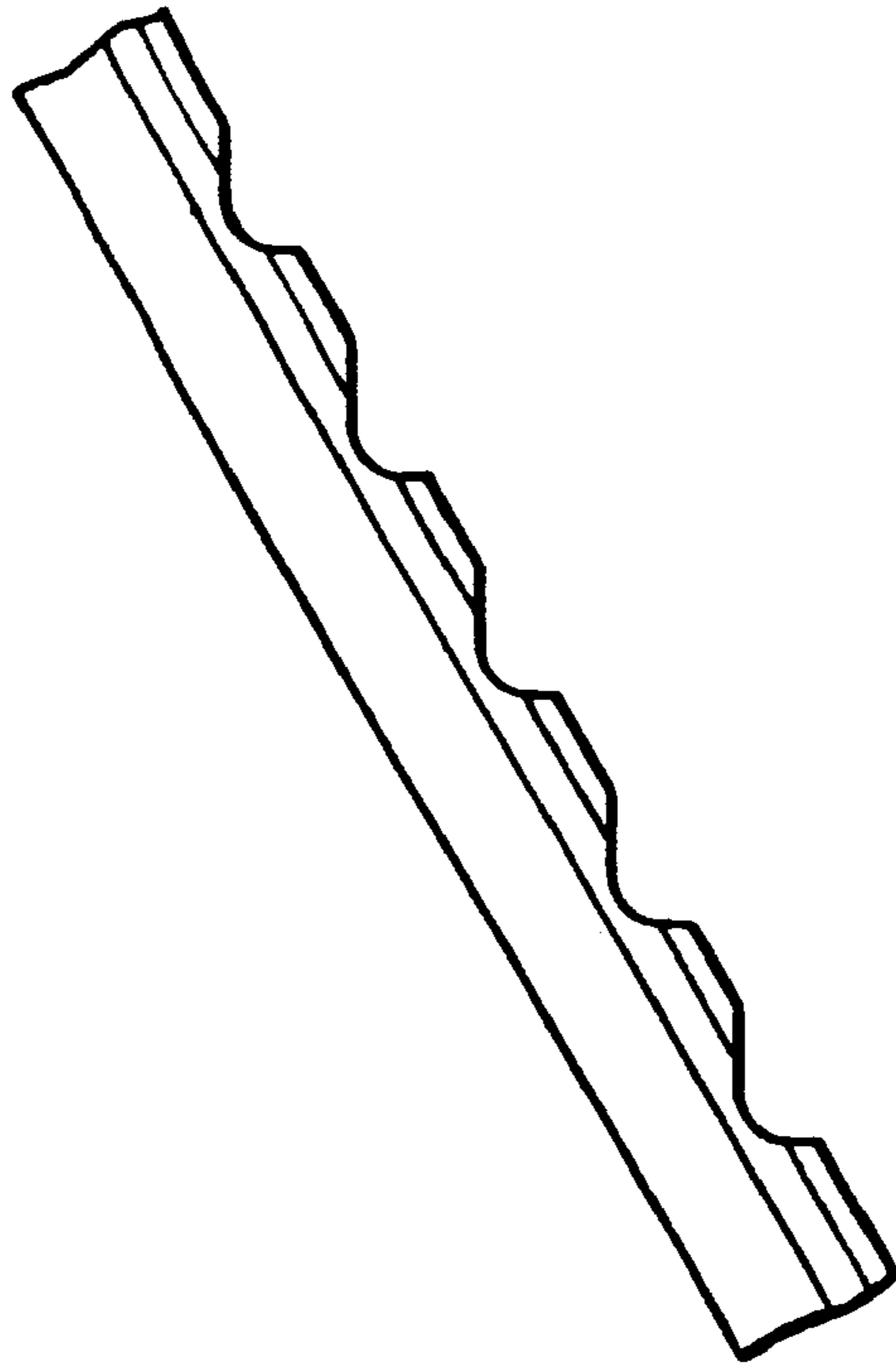

FIG. 7

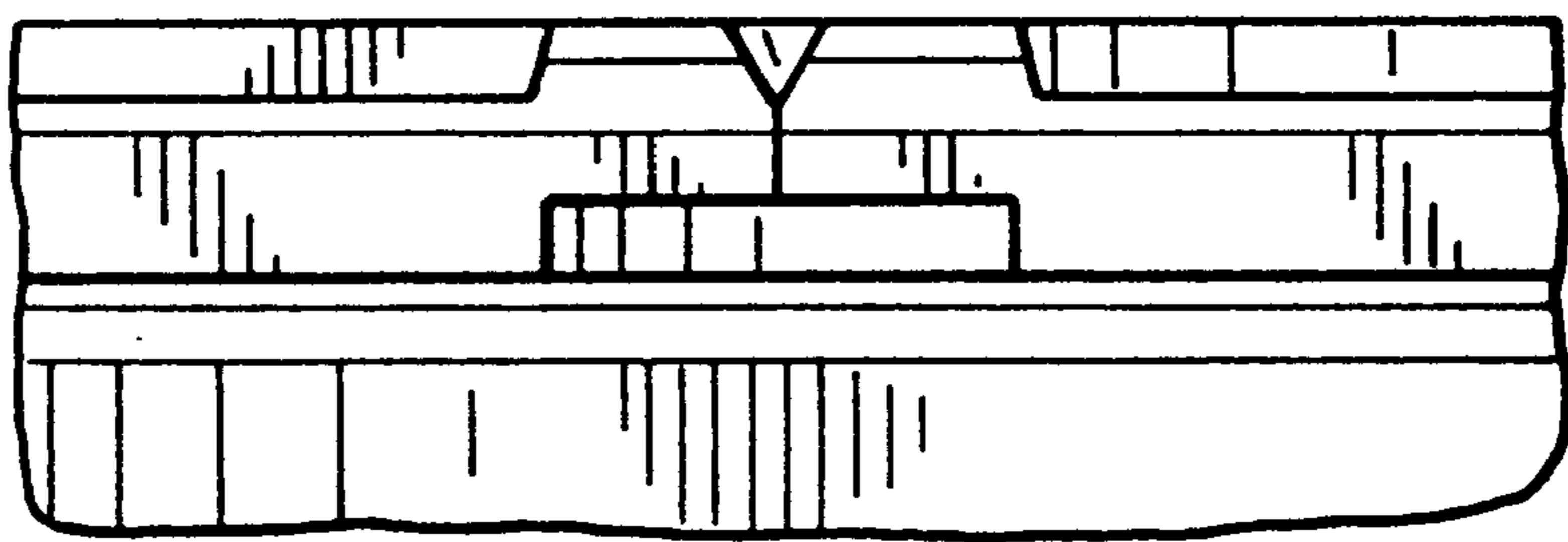

FIG. 8