



US00D447124B1

(12) **United States Design Patent**
Morimiya et al.

(10) **Patent No.:** **US D447,124 S**

(45) **Date of Patent:** **** Aug. 28, 2001**

(54) **MONITOR TELEVISION RECEIVER**

(75) Inventors: **Yuji Morimiya; Akio Suzuki**, both of Tokyo (JP)

(73) Assignee: **Sony Corporation**, Tokyo (JP)

(**) Term: **14 Years**

(21) Appl. No.: **29/108,239**

(22) Filed: **Jul. 26, 1999**

(30) **Foreign Application Priority Data**

Jan. 26, 1999 (JP) 11-1488

(51) **LOC (7) Cl.** **14-03**

(52) **U.S. Cl.** **D14/126**

(58) **Field of Search** D14/305-307,
D14/335-337, 371, 374-382, 432, 439,
448-450, 125, 126, 128-131, 217, 239;
348/836, 838, 825; 312/7.2

(56) **References Cited**

U.S. PATENT DOCUMENTS

- D. 303,380 * 9/1989 Grange et al. D14/380
- D. 312,453 * 11/1990 Oh D14/379
- D. 326,260 * 5/1992 Oshima D14/380
- D. 364,608 * 11/1995 Nakada D14/380
- D. 370,896 * 6/1996 Kuo D14/380
- D. 413,595 9/1999 Arie D14/126

- 5,666,263 * 9/1997 Mundt et al. 312/223.1 X
- 5,969,776 * 10/1999 Han 348/836
- 5,990,940 * 11/1999 Hashimoto et al. 348/184

OTHER PUBLICATIONS

Catalog: "88"; Sony; Mar. 1998; pp. 205 & 206.

* cited by examiner

Primary Examiner—Ted Shooman

Assistant Examiner—C Tuttle

(74) *Attorney, Agent, or Firm*—Rader, Fishman & Grauer, PLLC

(57) **CLAIM**

The ornamental design for a monitor television receiver, as shown and described.

DESCRIPTION

FIG. 1 is a perspective view of a monitor television receiver showing our new design;
 FIG. 2 is a top plan view thereof;
 FIG. 3 is a left side elevational view thereof;
 FIG. 4 is a front elevational view thereof;
 FIG. 5 is a bottom plan view thereof;
 FIG. 6 is a right side elevational view thereof; and,
 FIG. 7 is a rear elevational view thereof.
 The portions shown in broken lines are for illustrative purposes only and form no part of the claimed design.

1 Claim, 4 Drawing Sheets

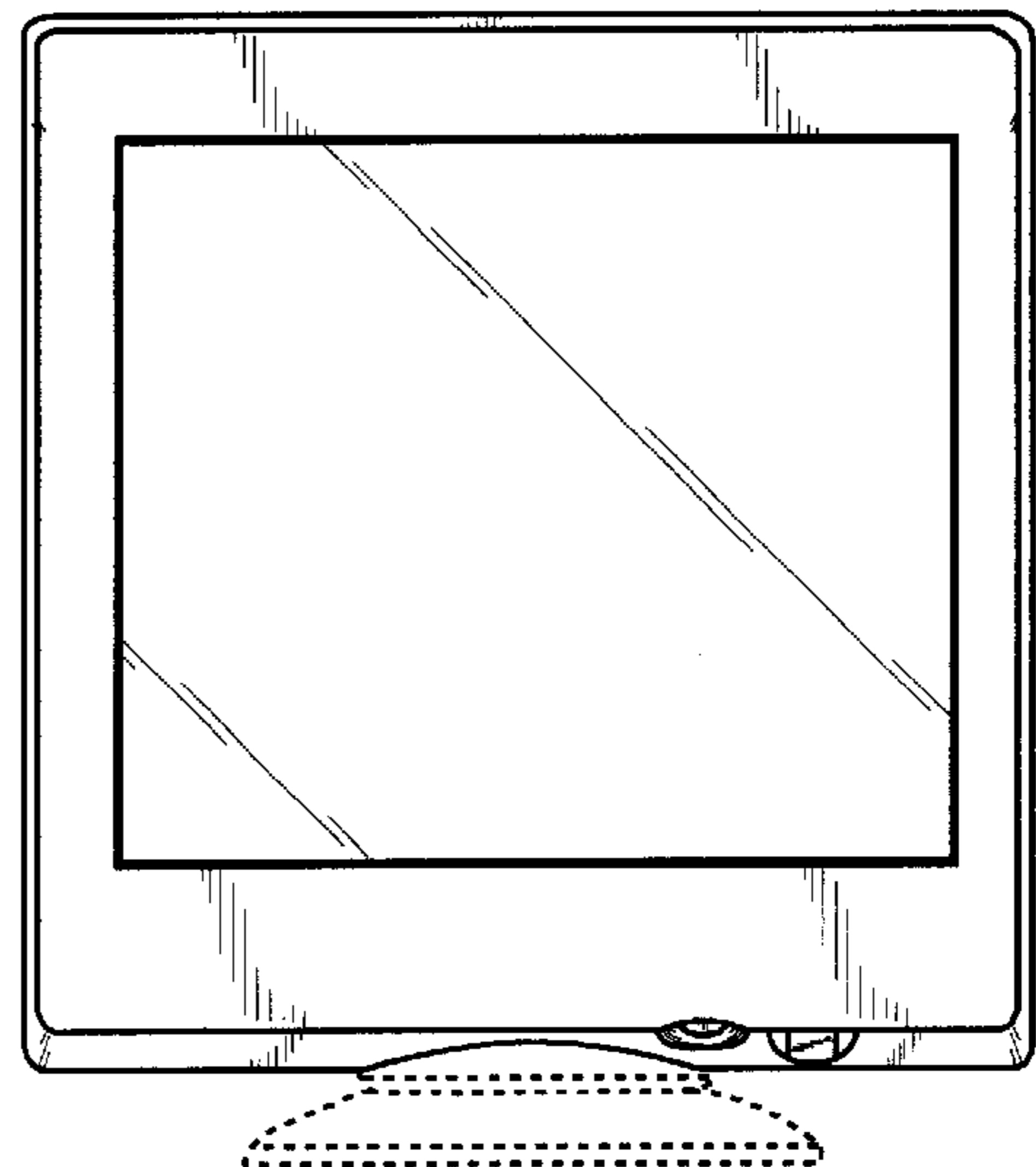
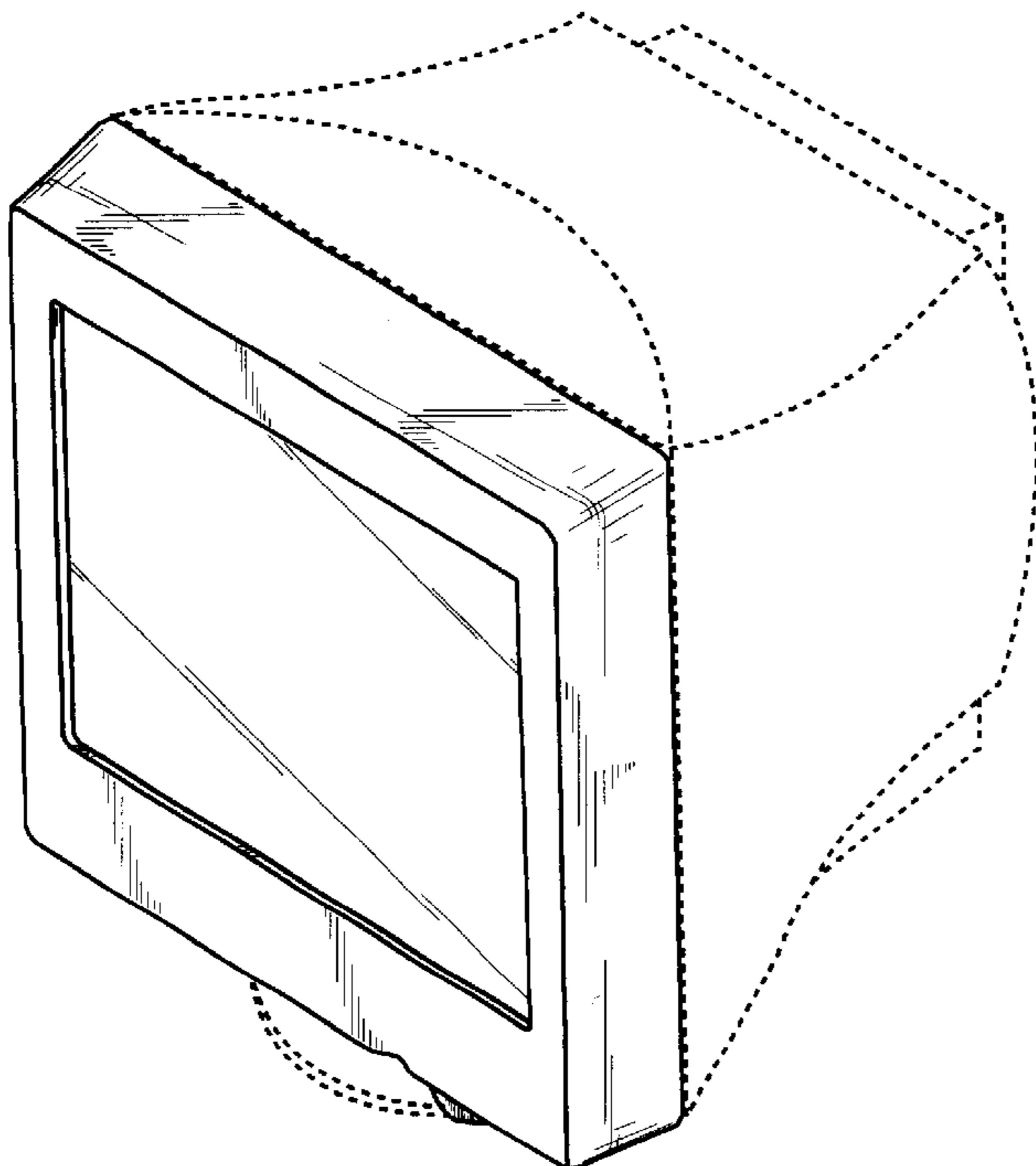

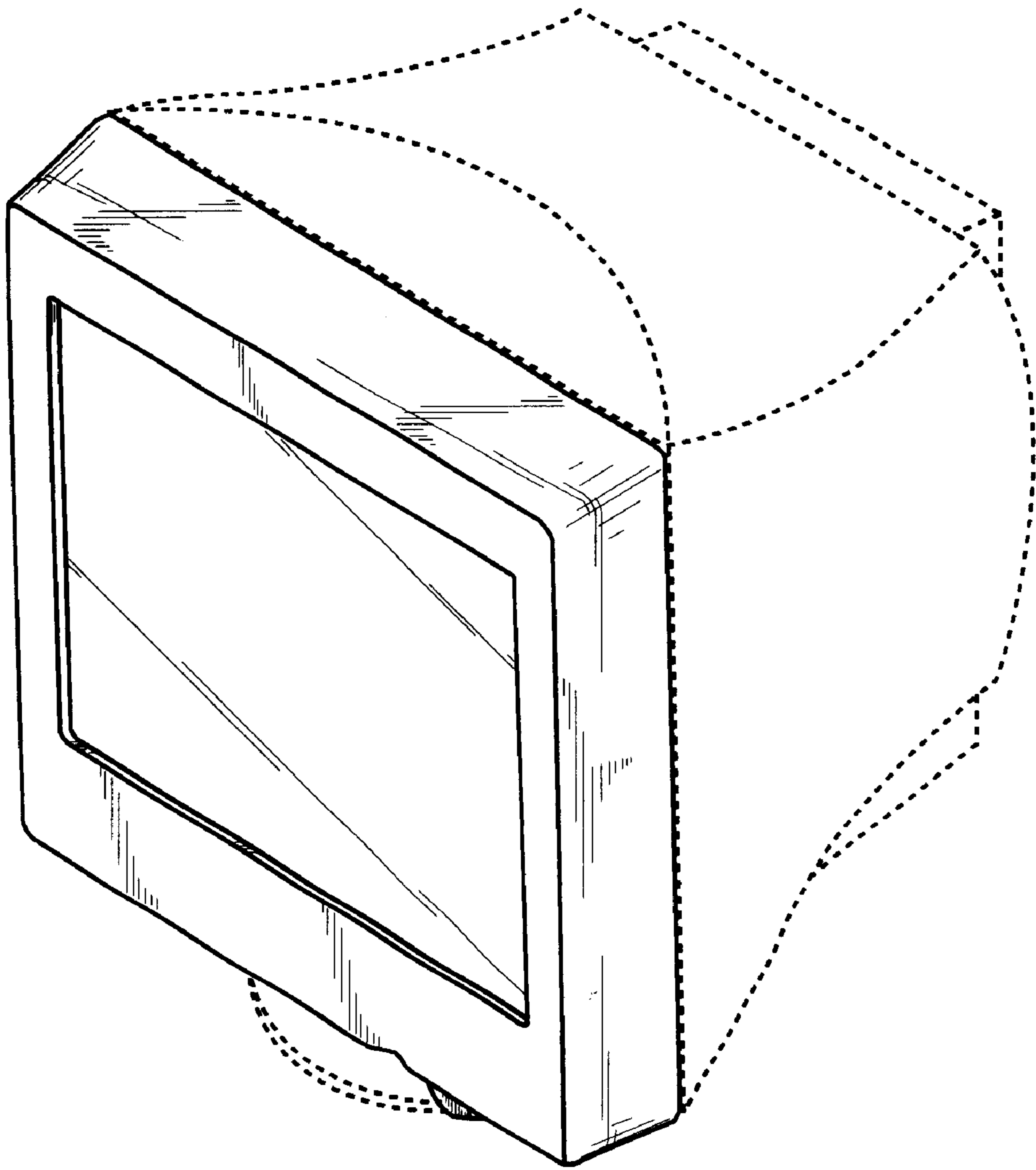

Fig. 1

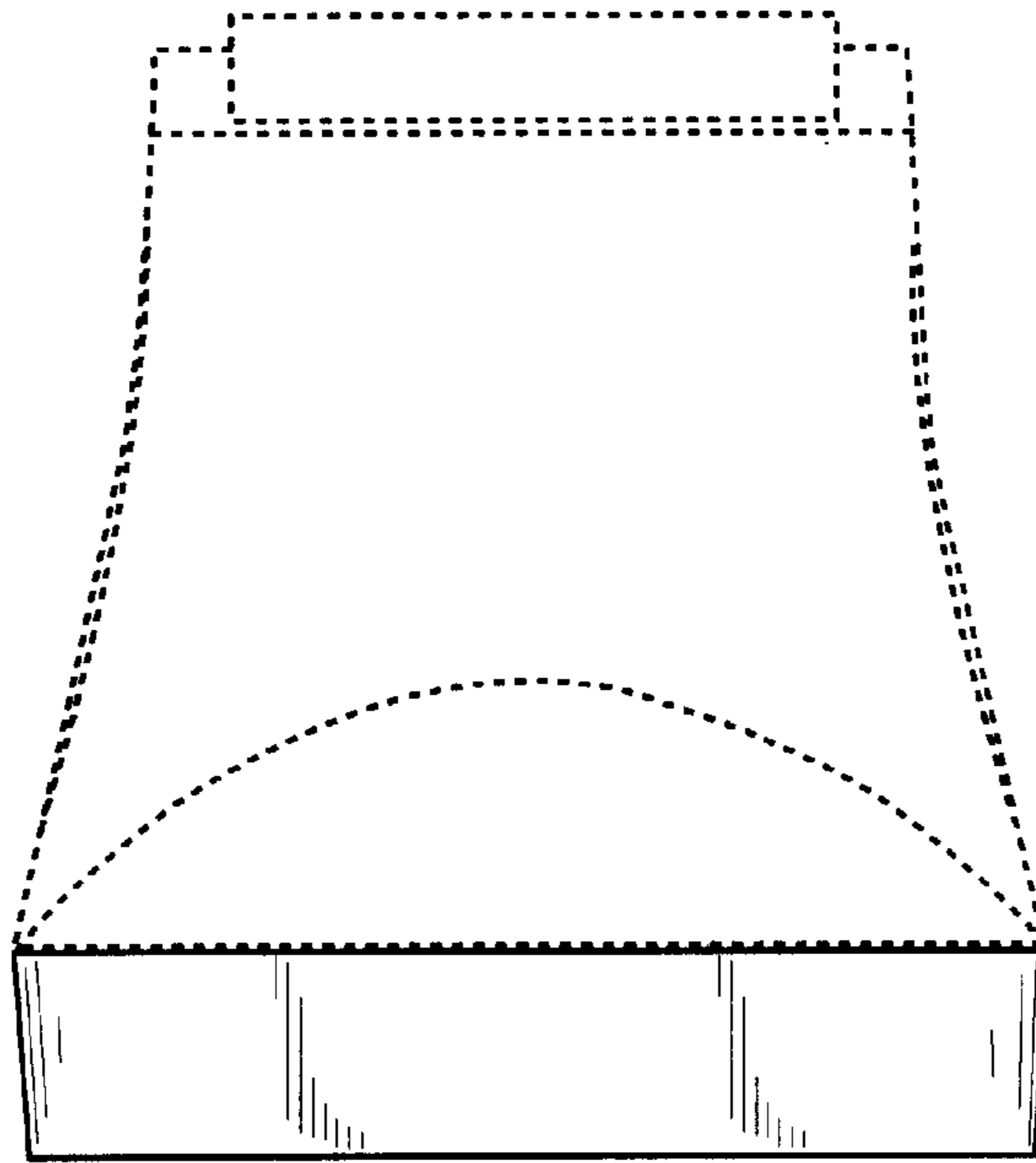

Fig. 2

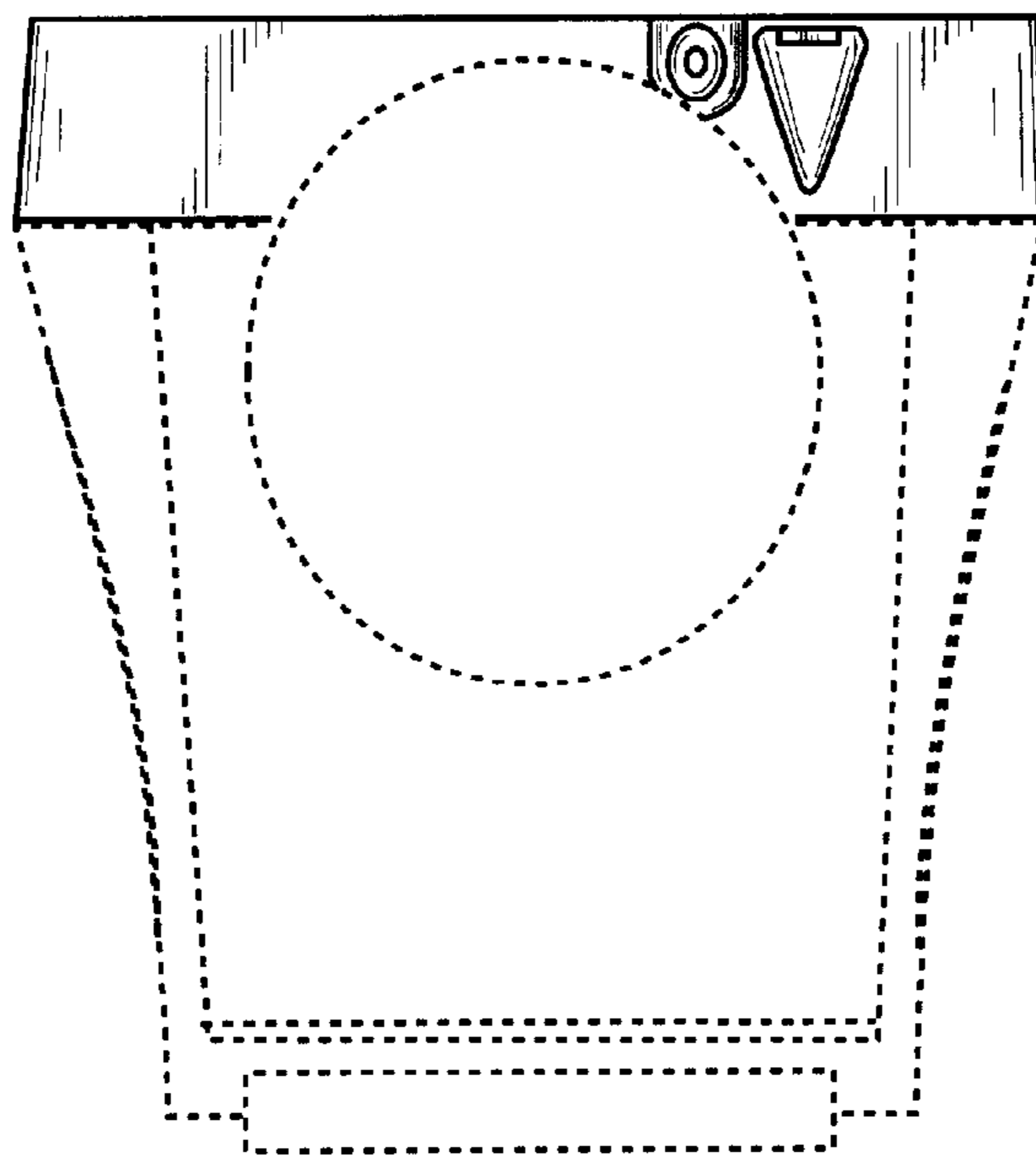

Fig. 5

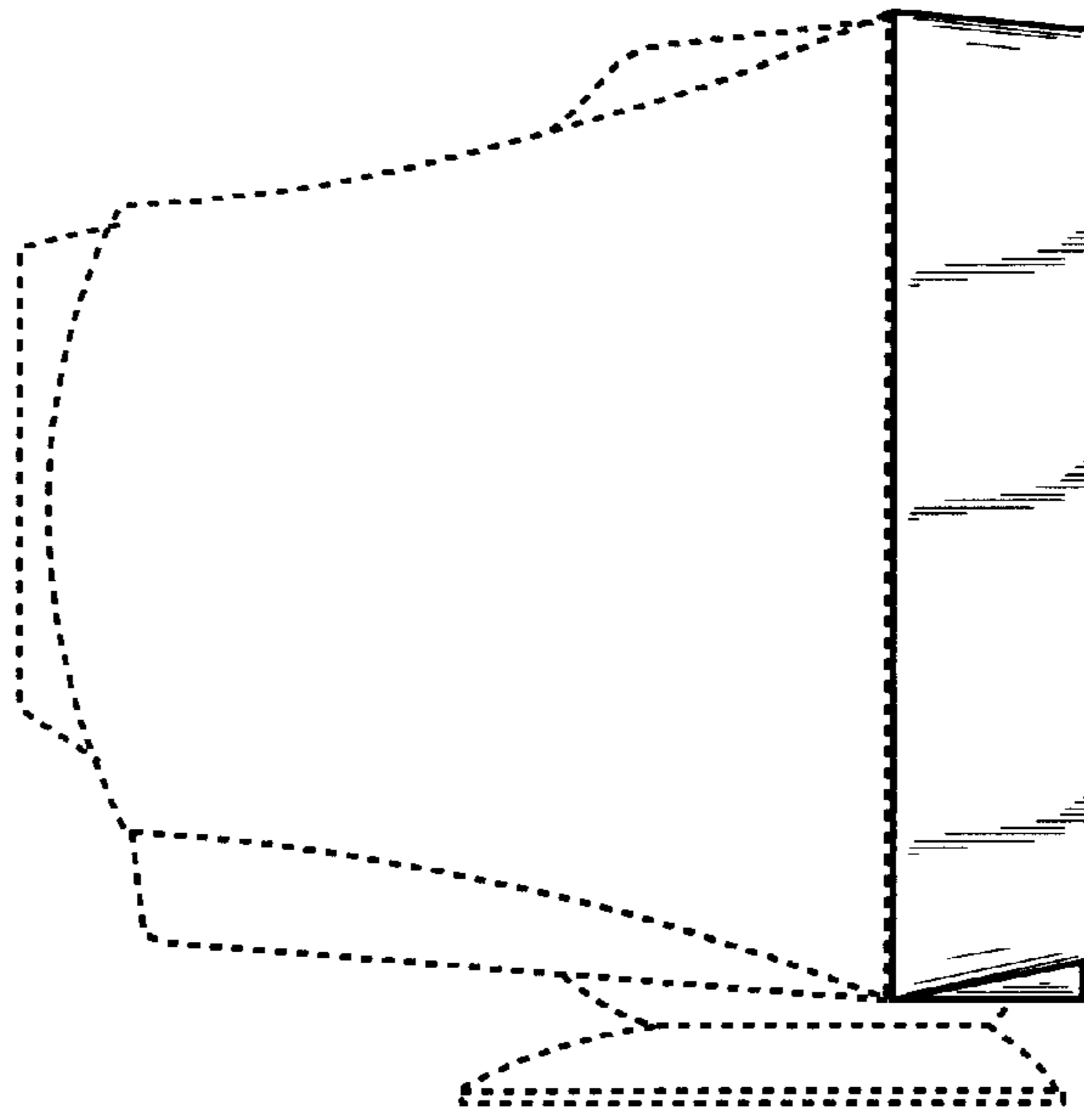

Fig. 3

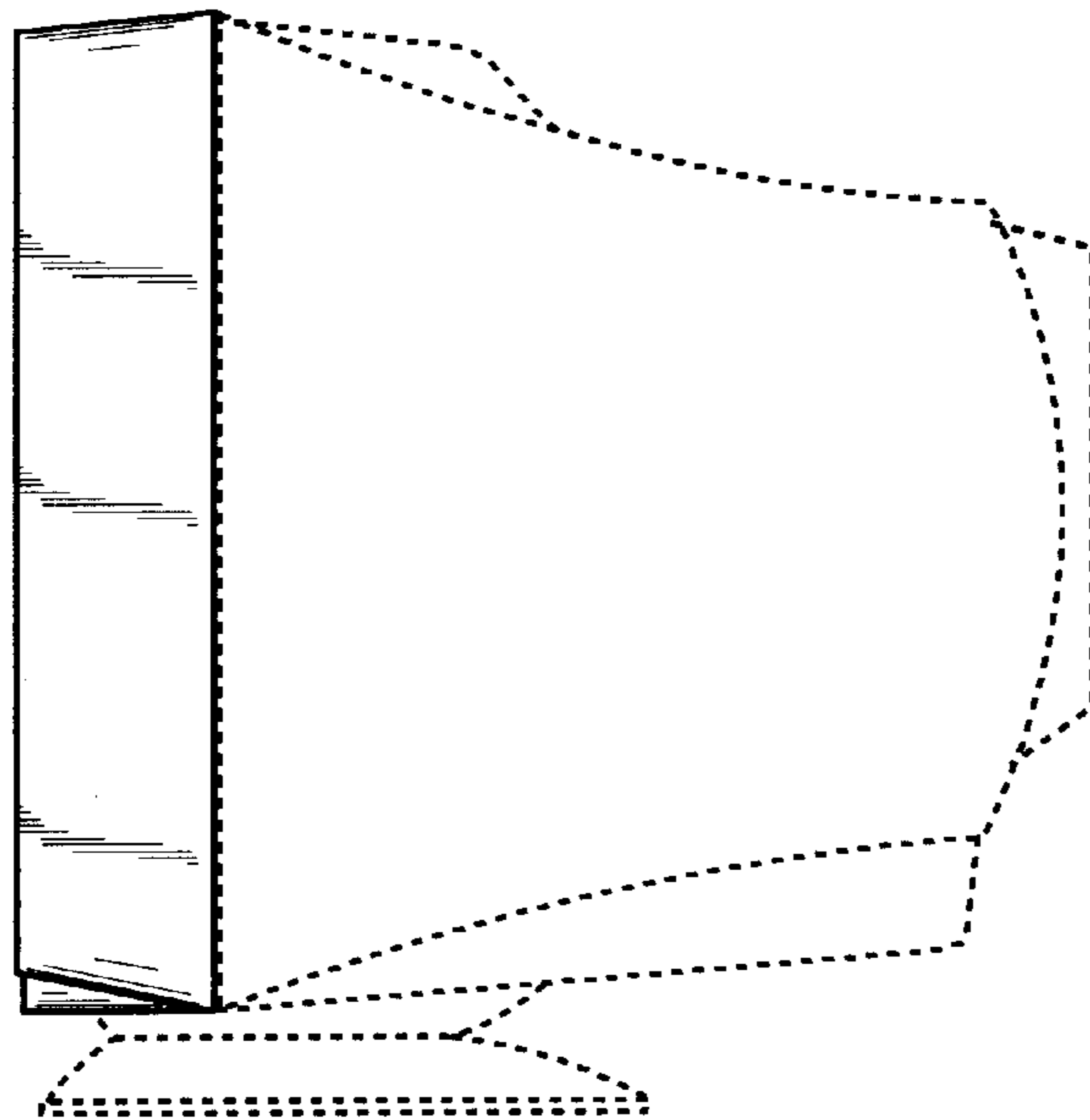

Fig. 6

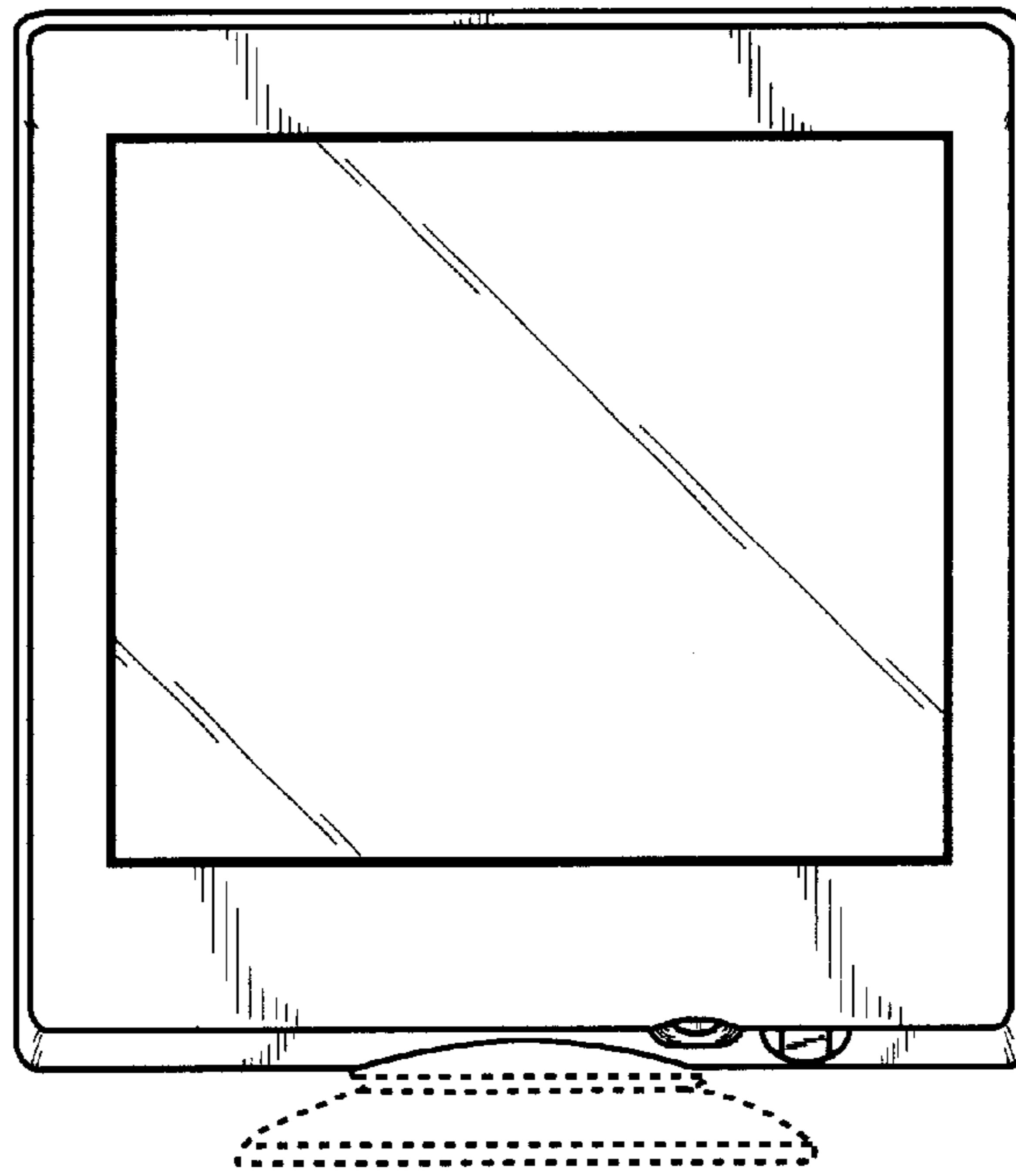

Fig. 4

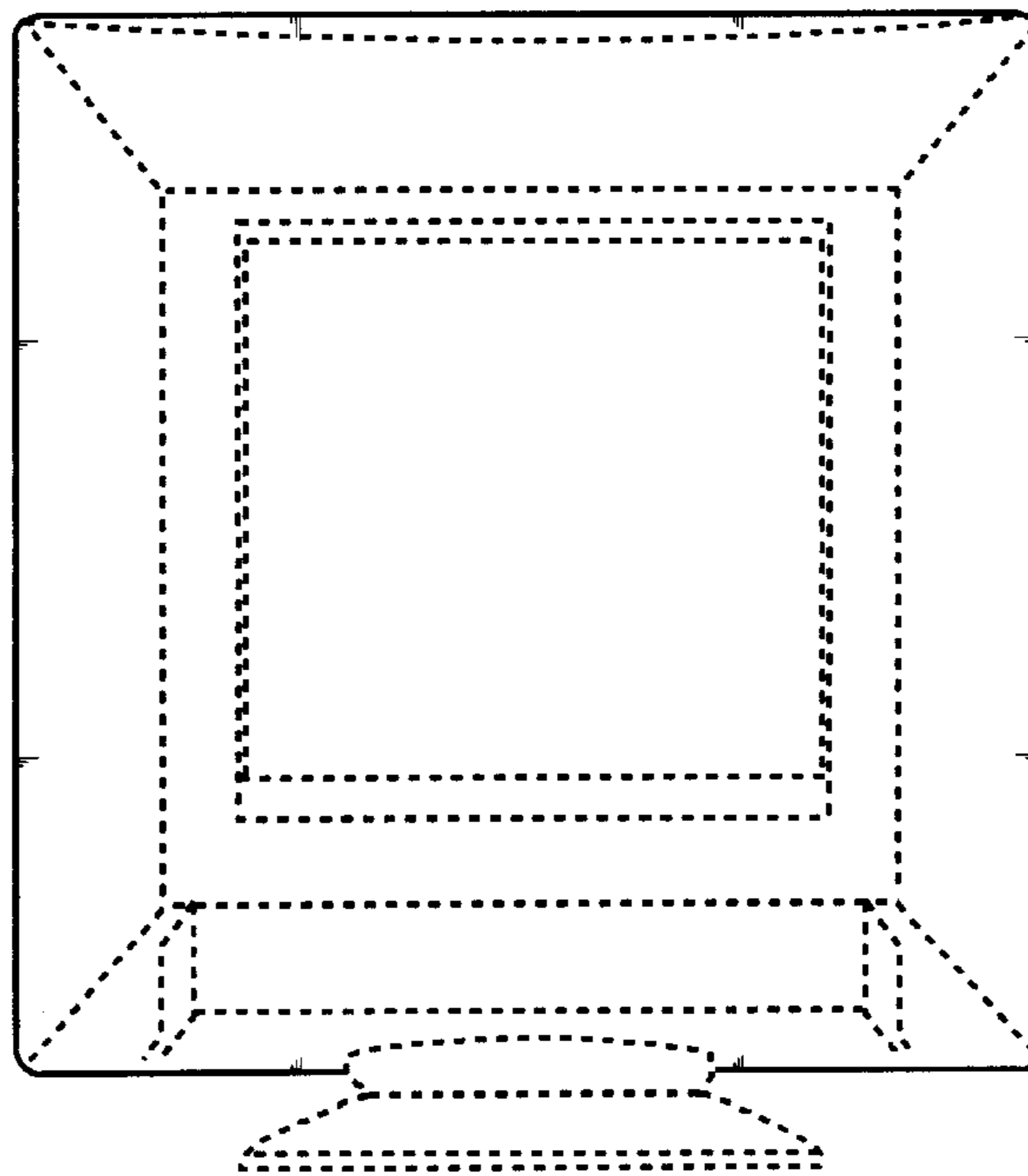

Fig. 7