



US00D447041B1

(12) **United States Design Patent**
Rivera

(10) **Patent No.:** **US D447,041 S**

(45) **Date of Patent:** **** Aug. 28, 2001**

(54) **HANDLE FOR A MULTIPURPOSE HAND TOOL**

(75) **Inventor:** **Benjamin C. Rivera**, West Linn, OR (US)

(73) **Assignee:** **Leatherman Tool Group, Inc.**, Portland, OR (US)

(*) **Notice:** This patent is subject to a terminal disclaimer.

(**) **Term:** **14 Years**

(21) **Appl. No.:** **29/132,026**

(22) **Filed:** **Oct. 31, 2000**

(51) **LOC (7) Cl.** **08-05**

(52) **U.S. Cl.** **D8/107; D8/105**

(58) **Field of Search** D8/51, 52, 54, D8/55, 105, 107, 99; 30/34, 143, 153, 155; 7/118, 119, 125, 127, 128, 129, 132, 158, 165, 167, 168; 81/305

(56) **References Cited**

U.S. PATENT DOCUMENTS

D. 380,362	*	7/1997	Rivera	D8/52
D. 384,872	*	10/1997	Yeh	D8/105
D. 385,169	*	10/1997	Rivera	D8/52
D. 392,519	*	3/1998	Hung	D8/5
D. 398,209		9/1998	Rivera	D8/52
D. 398,213		9/1998	Rivera	D8/105
D. 401,133	*	11/1998	Gardiner et al.	D8/105
D. 414,092	*	9/1999	Chang	D8/55
D. 423,893	*	5/2000	Mackin et al.	D8/52
D. 426,446	*	6/2000	Chau	D8/105

D. 426,447	*	6/2000	Chau	D8/105
D. 429,616	*	8/2000	Rivera	D8/105
5,029,354		7/1991	Boyd, Jr. et al.	7/118
5,537,750		7/1996	Seber et al.	30/161
5,564,318		10/1996	Pail	81/427.5
5,809,599	*	9/1998	Frazer	7/128
5,978,993	*	11/1999	Rivera	7/128
6,014,787		1/2000	Rivera	7/128
6,092,444		7/2000	Hsiao	81/440

OTHER PUBLICATIONS

Hong Kong Enterprise Catalog Mar. 1989 p. 12.*

* cited by examiner

Primary Examiner—Alan P. Douglas

Assistant Examiner—Clare E. Heflin

(74) *Attorney, Agent, or Firm*—Chernoff, Vilhauer, McClung & Stenzel LLP

(57) **CLAIM**

The ornamental design for a handle for a multipurpose hand tool, as shown and described.

DESCRIPTION

FIG. 1 is an isometric view from the upper left end of a handle for a multipurpose hand tool, showing my new design;

FIG. 2 is a side elevational view thereof, the opposite side elevational view thereof being identical with FIG. 2;

FIG. 3 is a top plan view thereof;

FIG. 4 is a bottom plan view thereof; and,

FIG. 5 is an end elevational view thereof, the opposite end elevational view thereof being identical with FIG. 5.

1 Claim, 2 Drawing Sheets

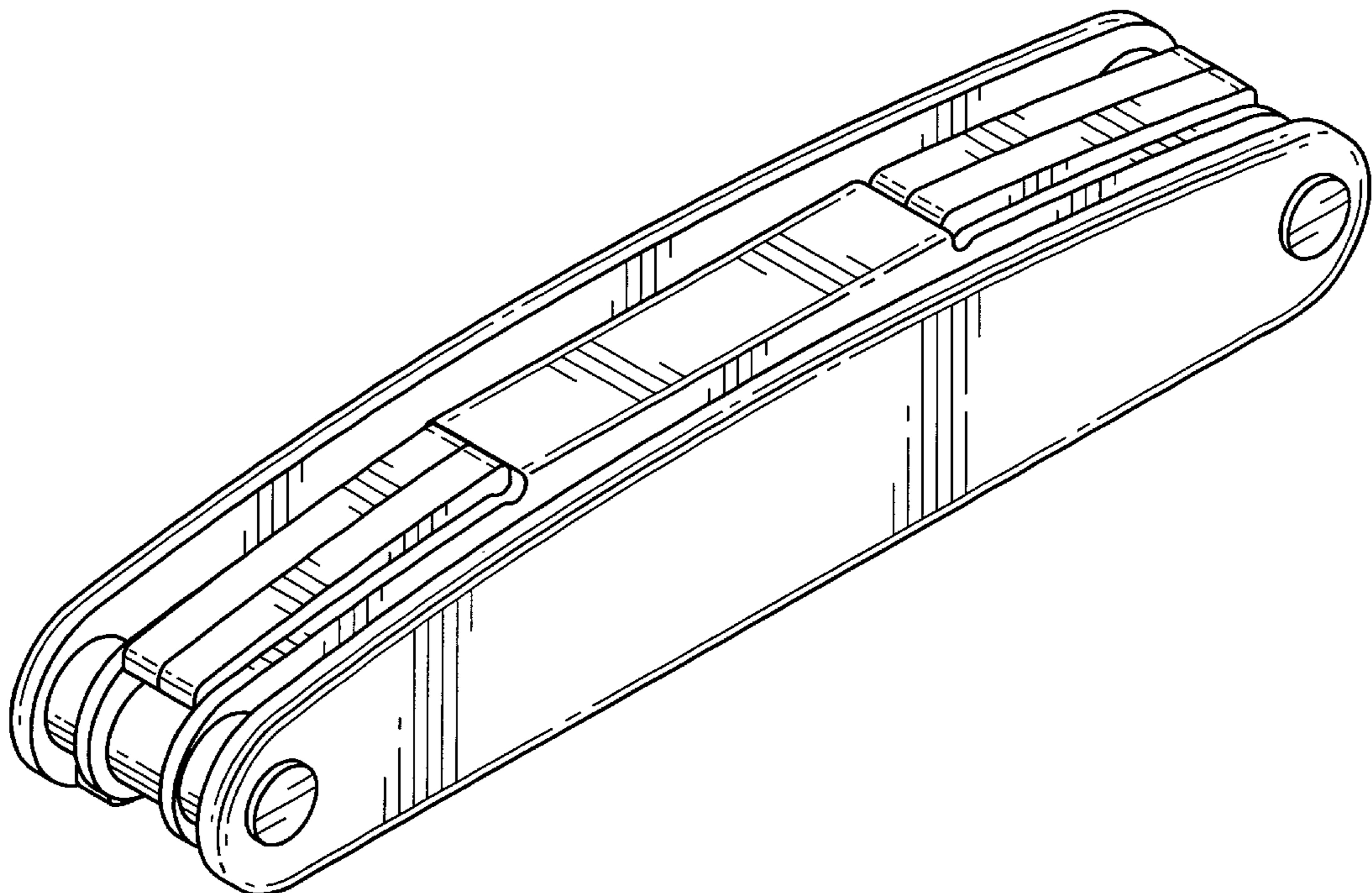

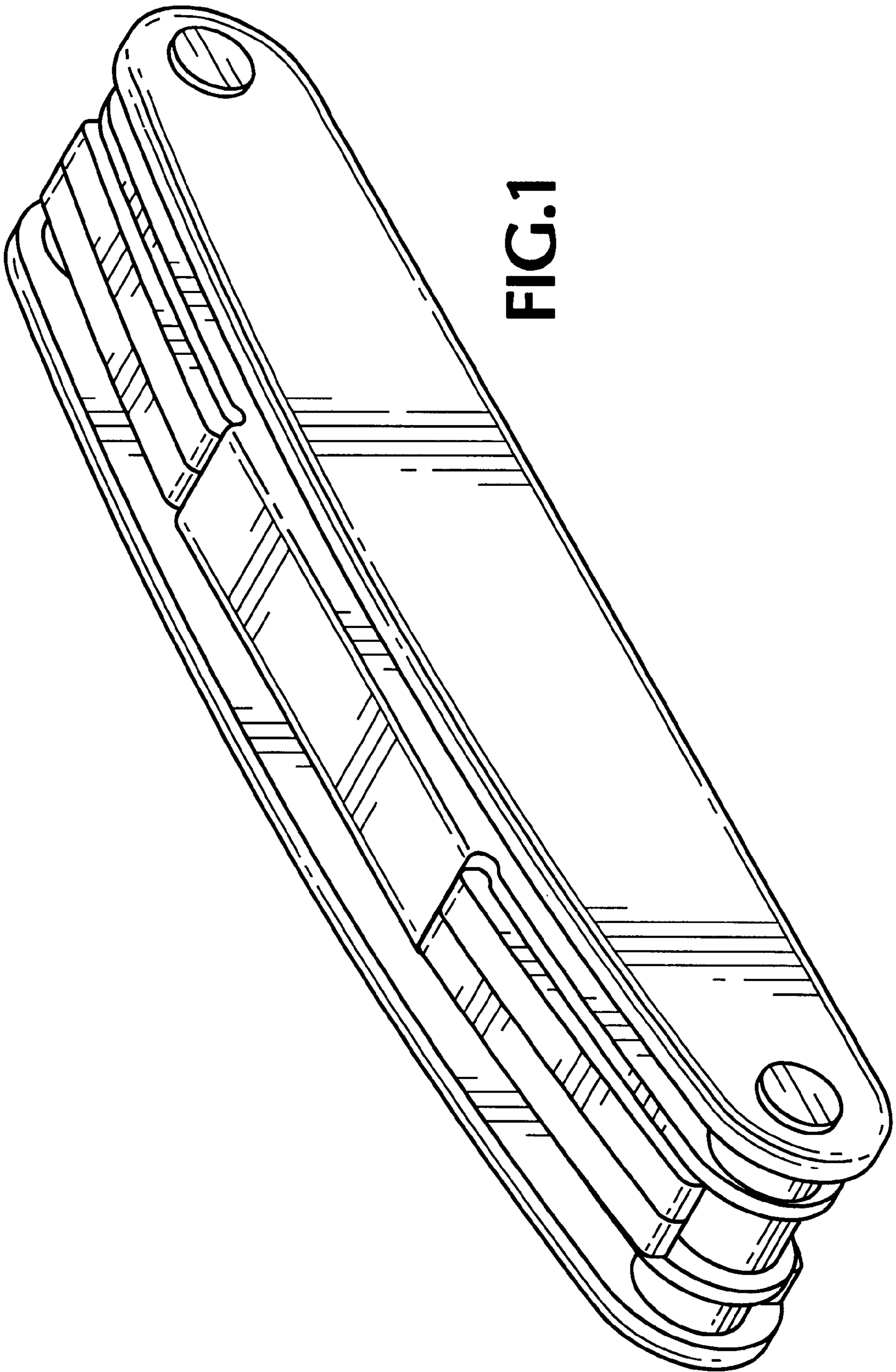

FIG.1

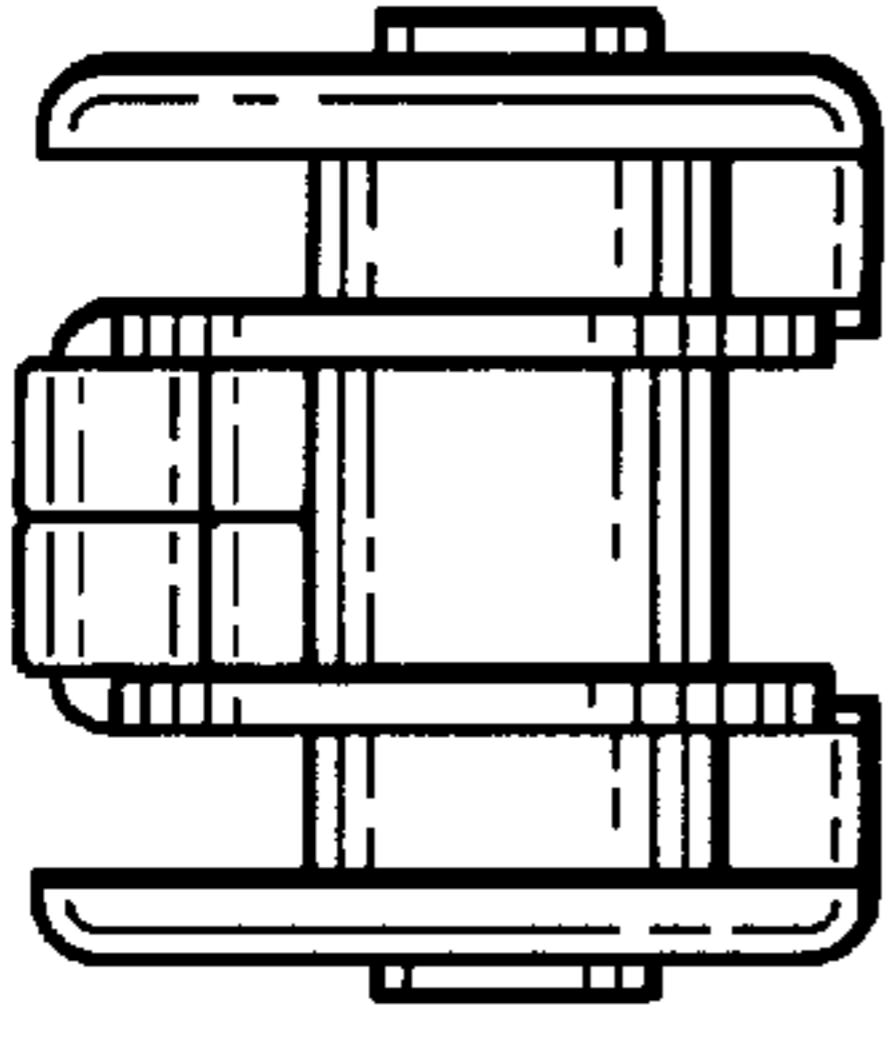

FIG. 5

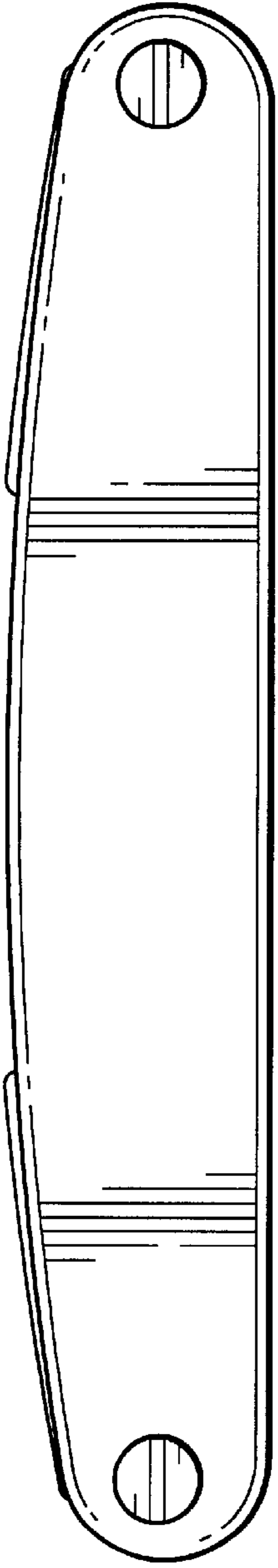

FIG. 2

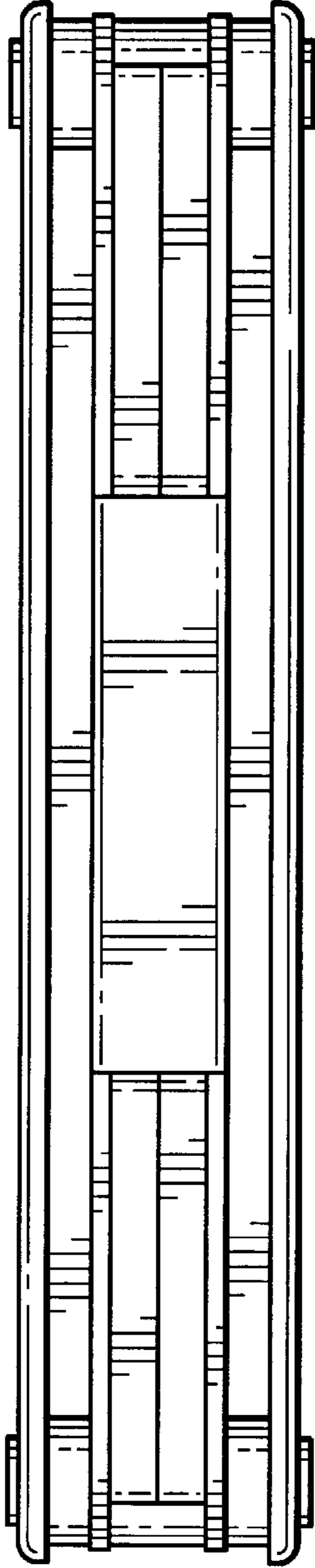

FIG. 3

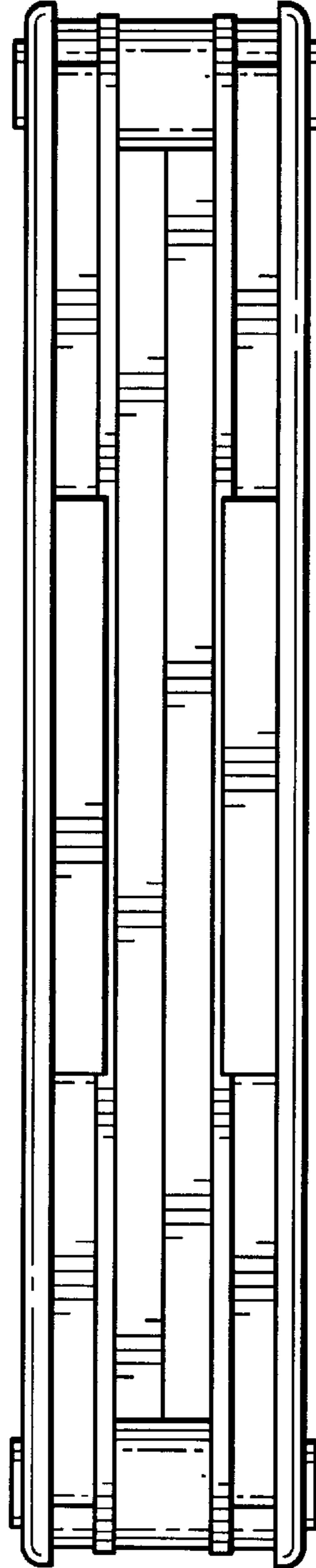

FIG. 4