



US00D446984B1

(12) **United States Design Patent**
Treon

(10) **Patent No.:** **US D446,984 S**

(45) **Date of Patent:** **** Aug. 28, 2001**

(54) **INTERLOCKING CONTOURED STADIUM SEATING SYSTEM**

(75) Inventor: **Steven R. Treon**, Bath, PA (US)

(73) Assignee: **Dant Clayton Corporation**, Louisville, KY (US)

(**) Term: **14 Years**

(21) Appl. No.: **29/129,832**

(22) Filed: **Sep. 22, 2000**

(51) **LOC (7) Cl.** **06-09**

(52) **U.S. Cl.** **D6/601**

(58) **Field of Search** D6/595, 596, 601, D6/604; 5/630, 636, 644, 652-654, 655, 655.3, 655.4, 655.5, 655.9, 656, 907; 297/228.12, 228.13, 219.1, 183.5

(56) **References Cited**

U.S. PATENT DOCUMENTS

- D. 367,198 * 2/1996 Wolf D6/601
- D. 386,035 * 11/1997 Matsler et al. D6/601
- 5,034,594 * 7/1991 Beezhold et al. 219/528

* cited by examiner

Primary Examiner—Janice E. Seeger

(74) *Attorney, Agent, or Firm*—Woodard, Emhardt, Naughton, Moriarty & McNett

(57) **CLAIM**

The ornamental design for an interlocking contoured stadium seating system, as shown and described.

DESCRIPTION

FIG. 1 is a perspective view of the first embodiment of my interlocking contoured stadium seating system, shown an interior seat module of my new design.

FIG. 2 is a top plan view of the first embodiment interior seat module of FIG. 1.

FIG. 3 is a bottom plan view of the first embodiment interior seat module of FIG. 1.

FIG. 4 is a front elevation view of the first embodiment interior seat module of FIG. 1.

FIG. 5 is a back elevation view of the first embodiment interior seat module of FIG. 1.

FIG. 6 is a right side elevation view of the first embodiment interior seat module of FIG. 1.

FIG. 7 is a left side elevation view of the first embodiment interior seat module of FIG. 1.

FIG. 8 is a perspective view of the second embodiment of my interlocking contoured stadium seating system, showing an interior seat module of my new design having wood grain texture.

FIG. 9 is a top plan view of the second embodiment interior seat module of FIG. 8. The other views of this second embodiment are the same as shown in FIGS. 3-7.

FIG. 10 is a perspective view of the third embodiment of my interlocking contoured stadium seating system, shown an interior seat module of my new design.

FIG. 11 is a top plan view of the third embodiment interior seat module of FIG. 10.

FIG. 12 is a bottom plan view of the third embodiment interior seat module of FIG. 10.

FIG. 13 is a front elevation view of the third embodiment interior seat module of FIG. 10.

FIG. 14 is a back elevation view of the third embodiment interior seat module of FIG. 10.

FIG. 15 is a right side elevation view of the third embodiment interior seat module of FIG. 10.

FIG. 16 is a left side elevation view of the third embodiment interior seat module of FIG. 10.

FIG. 17 is a perspective view of the fourth embodiment of my interlocking contoured stadium seating system, showing an interior seat module of my new design having wood grain texture.

FIG. 18 is a top plan view of the fourth embodiment interior seat module of FIG. 17. The other views of this fourth embodiment are the same as shown in FIGS. 12-16.

FIG. 19 is a perspective view of the fifth embodiment of my interlocking contoured stadium seating system, shown an aisle seat module of my new design.

FIG. 20 is a top plan view of the fifth embodiment aisle seat module of FIG. 19.

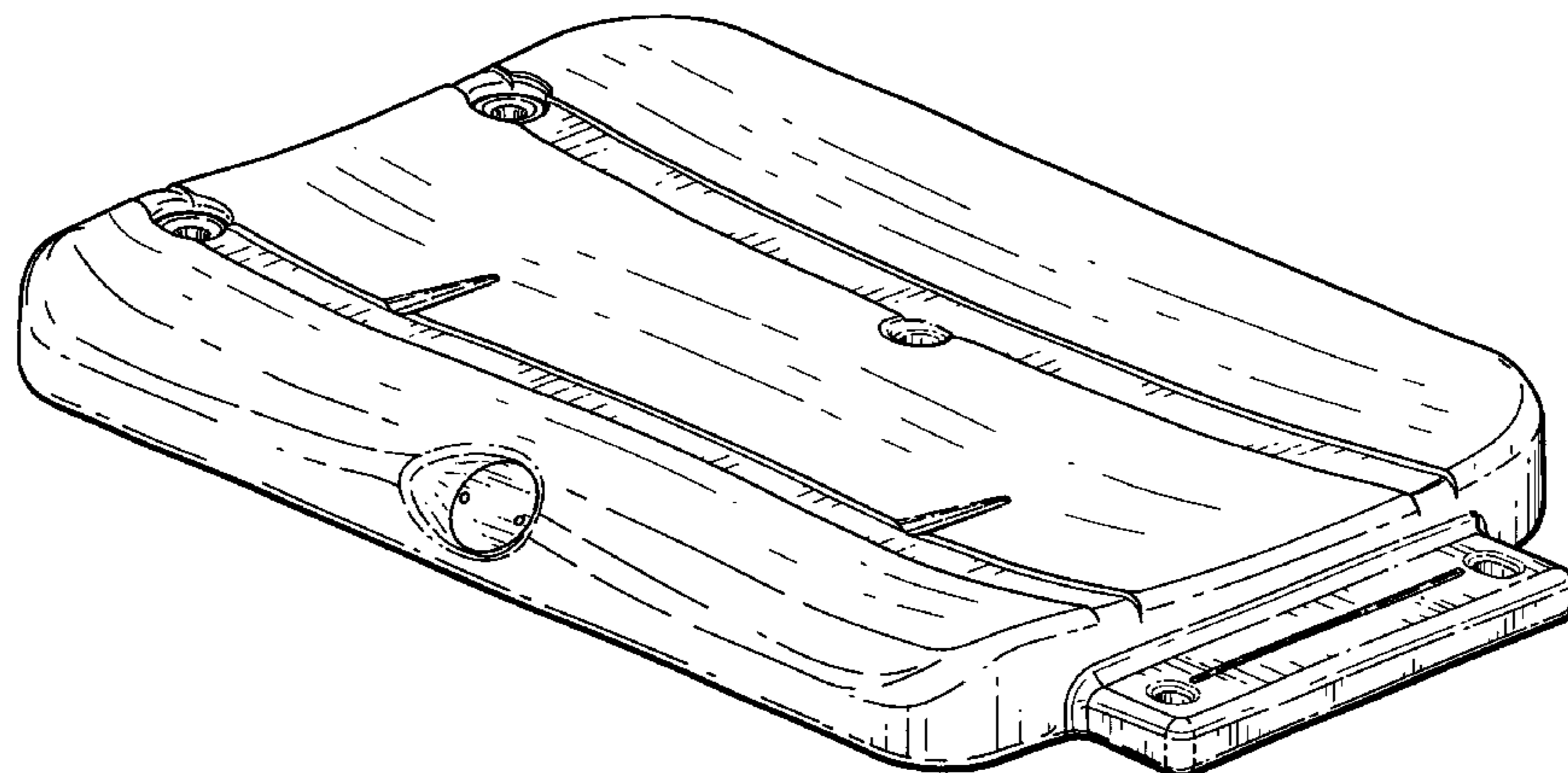

FIG. **21** is a bottom plan view of the fifth embodiment aisle seat module of FIG. **19**.

FIG. **22** is a front elevation view of the fifth embodiment aisle seat module of FIG. **19**.

FIG. **23** is a back elevation view of the fifth embodiment aisle seat module of FIG. **19**.

FIG. **24** is a right side elevation view of the fifth embodiment aisle seat module of FIG. **19**.

FIG. **25** is a left side elevation view of the fifth embodiment aisle seat module of FIG. **19**.

FIG. **26** is a perspective view of the sixth embodiment of my interlocking contoured stadium seating system, shown an aisle seat module of my new design having wood grain texture; and,

FIG. **27** is a top plan view of the sixth embodiment aisle seat module of FIG. **26**. The other views of this sixth embodiment are the same as shown in FIGS. **21–25**.

1 Claim, 15 Drawing Sheets

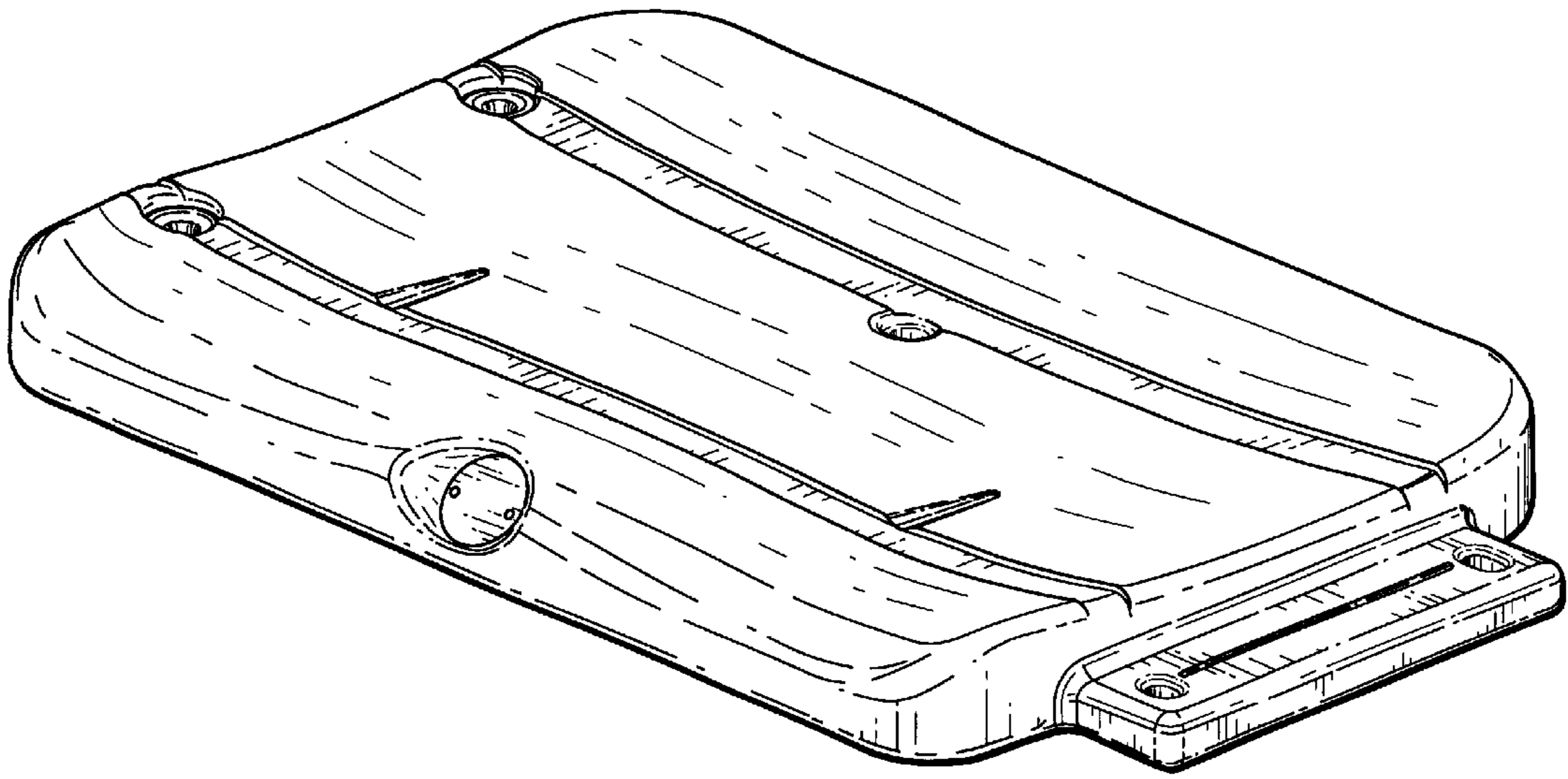

Fig. 1

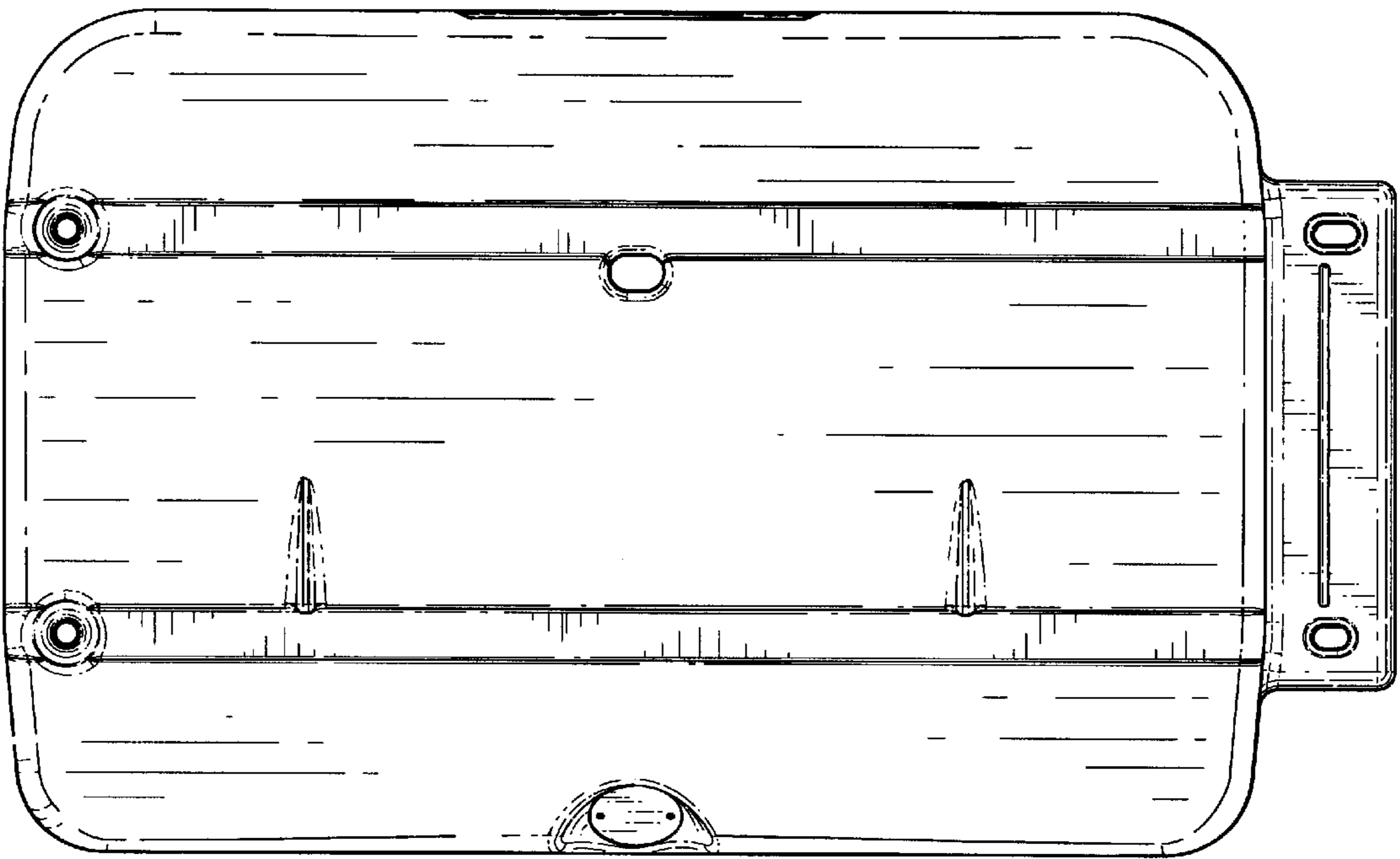

Fig. 2

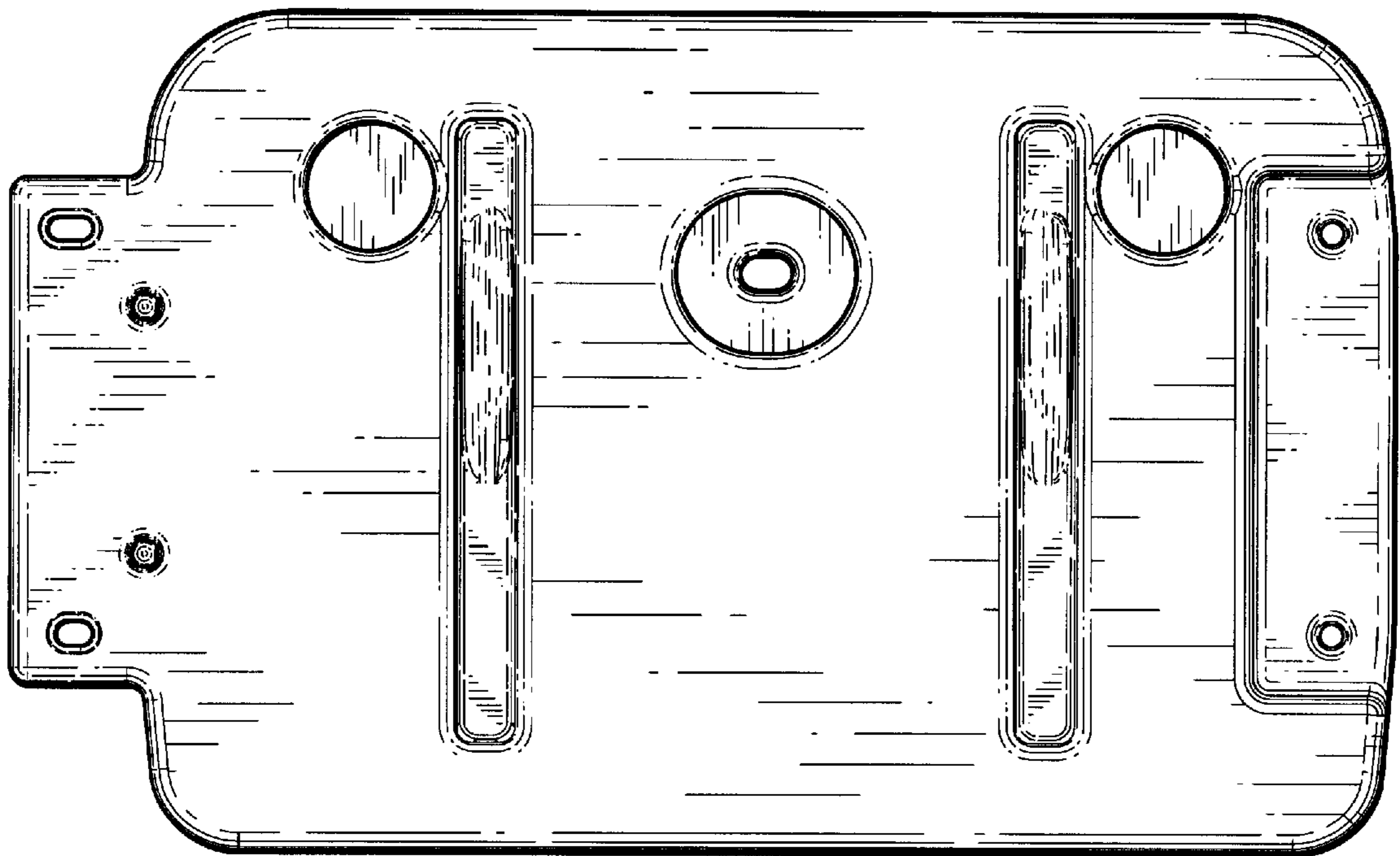

Fig. 3

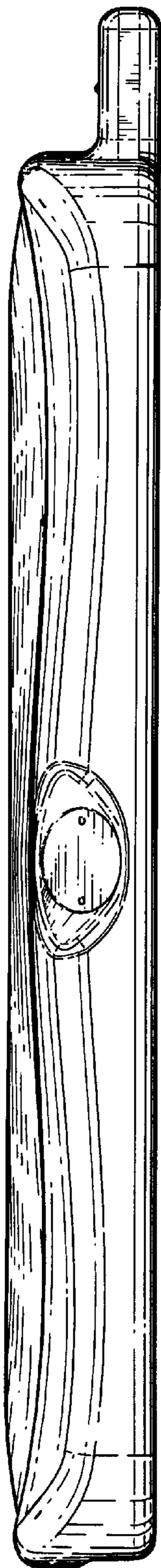

Fig. 4

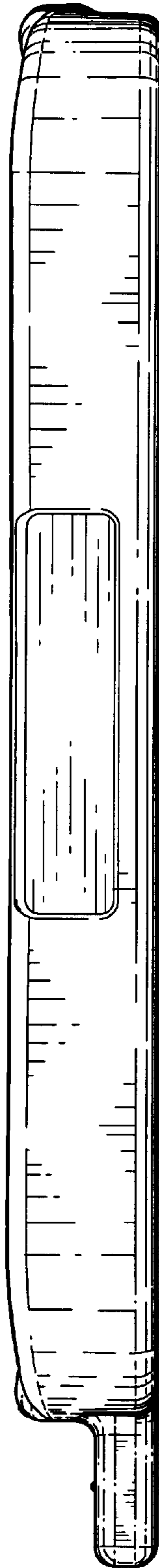

Fig. 5

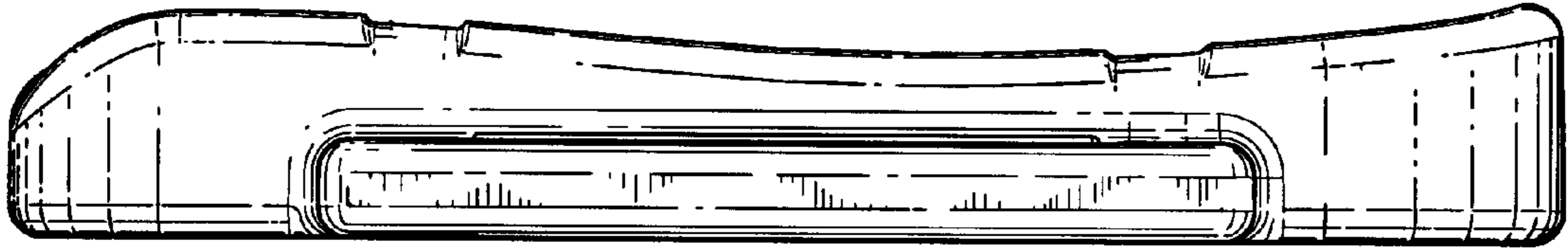

Fig. 6

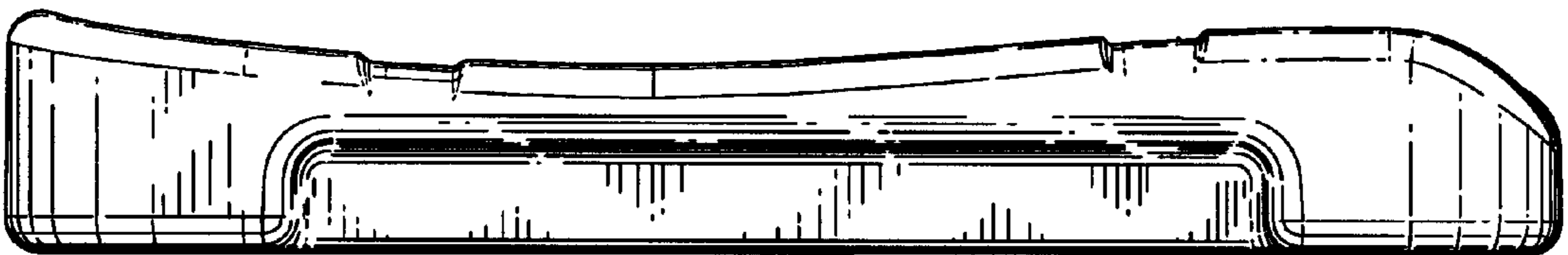

Fig. 7

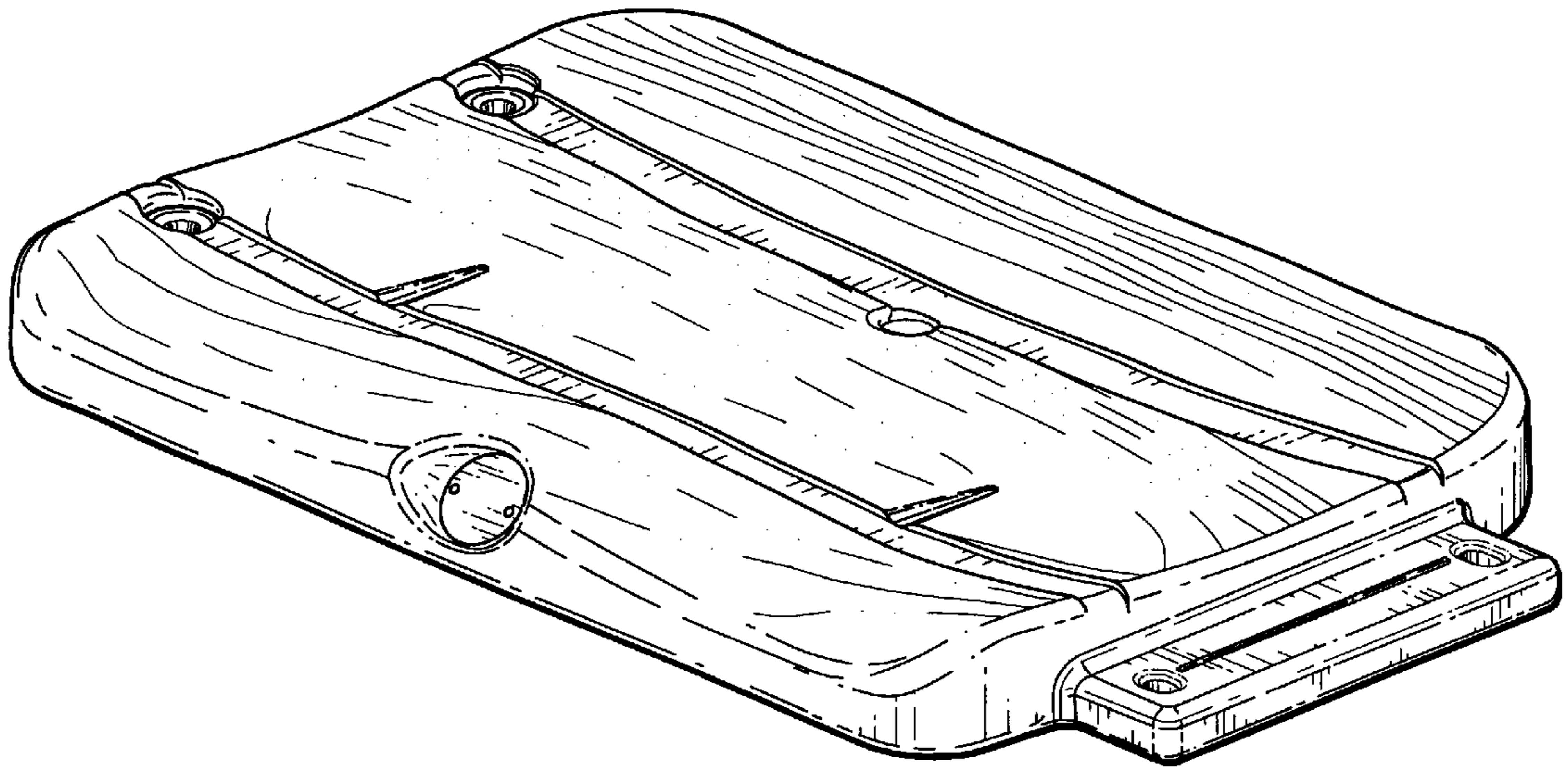

Fig. 8

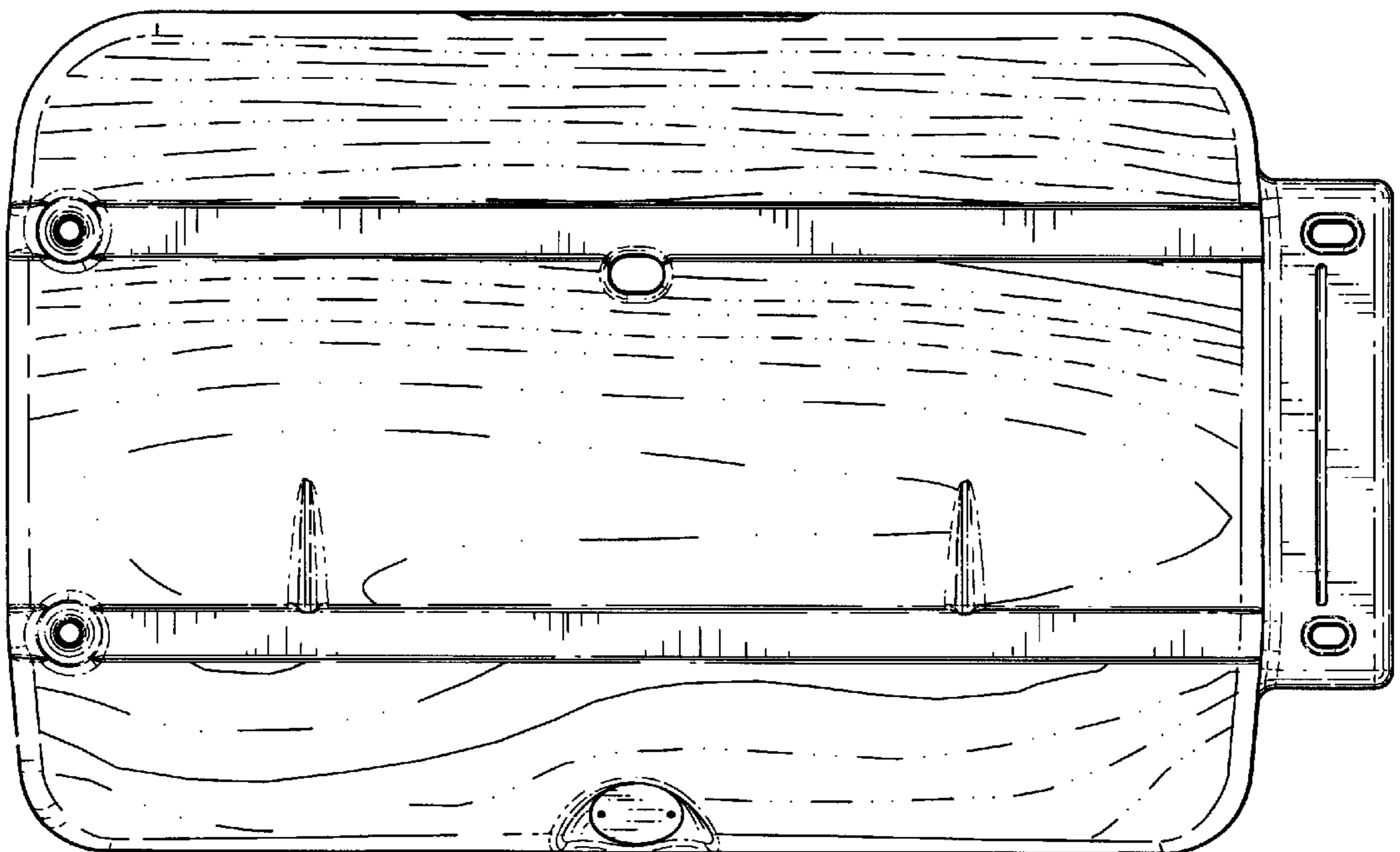

Fig. 9

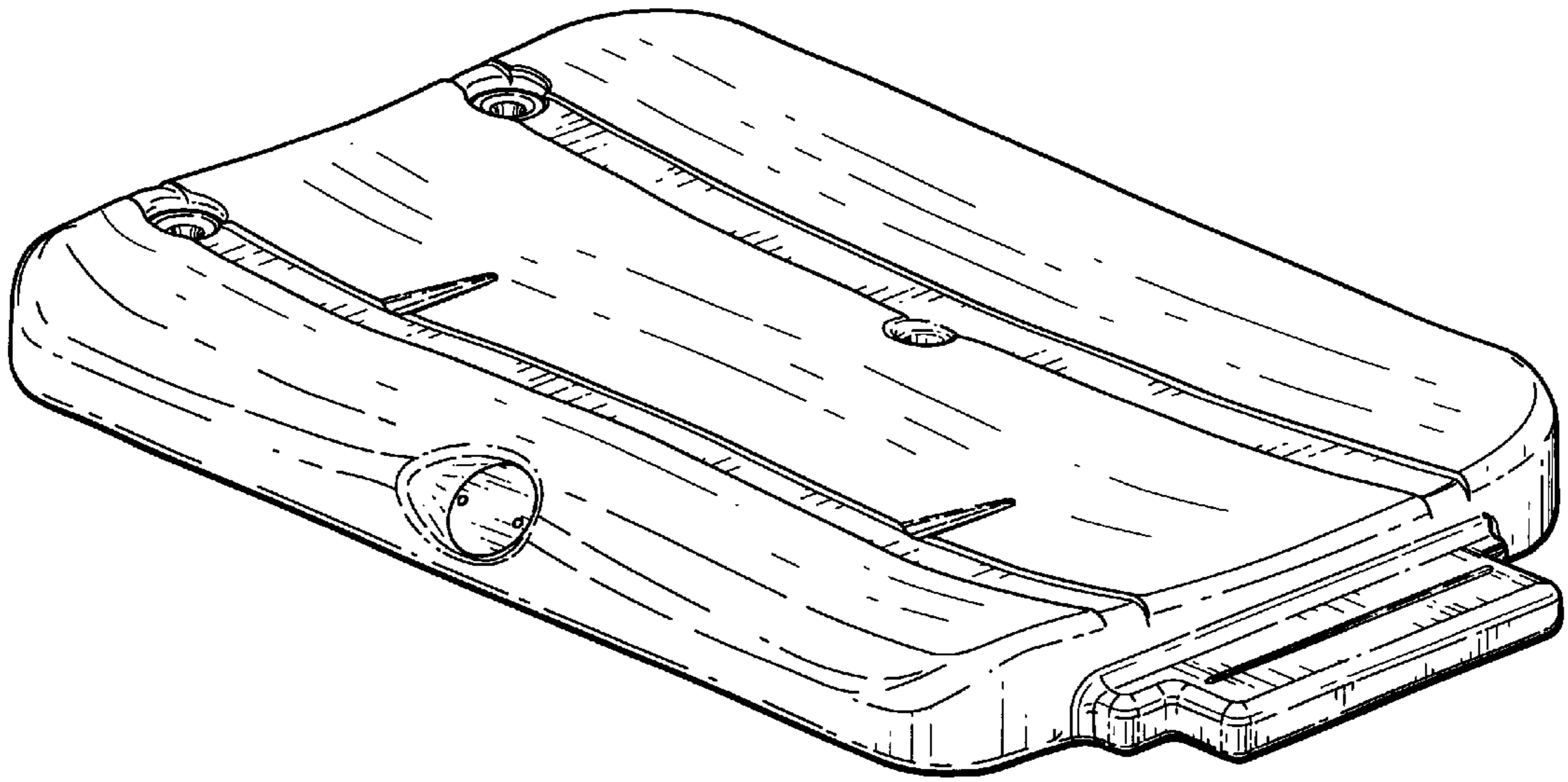

Fig. 10

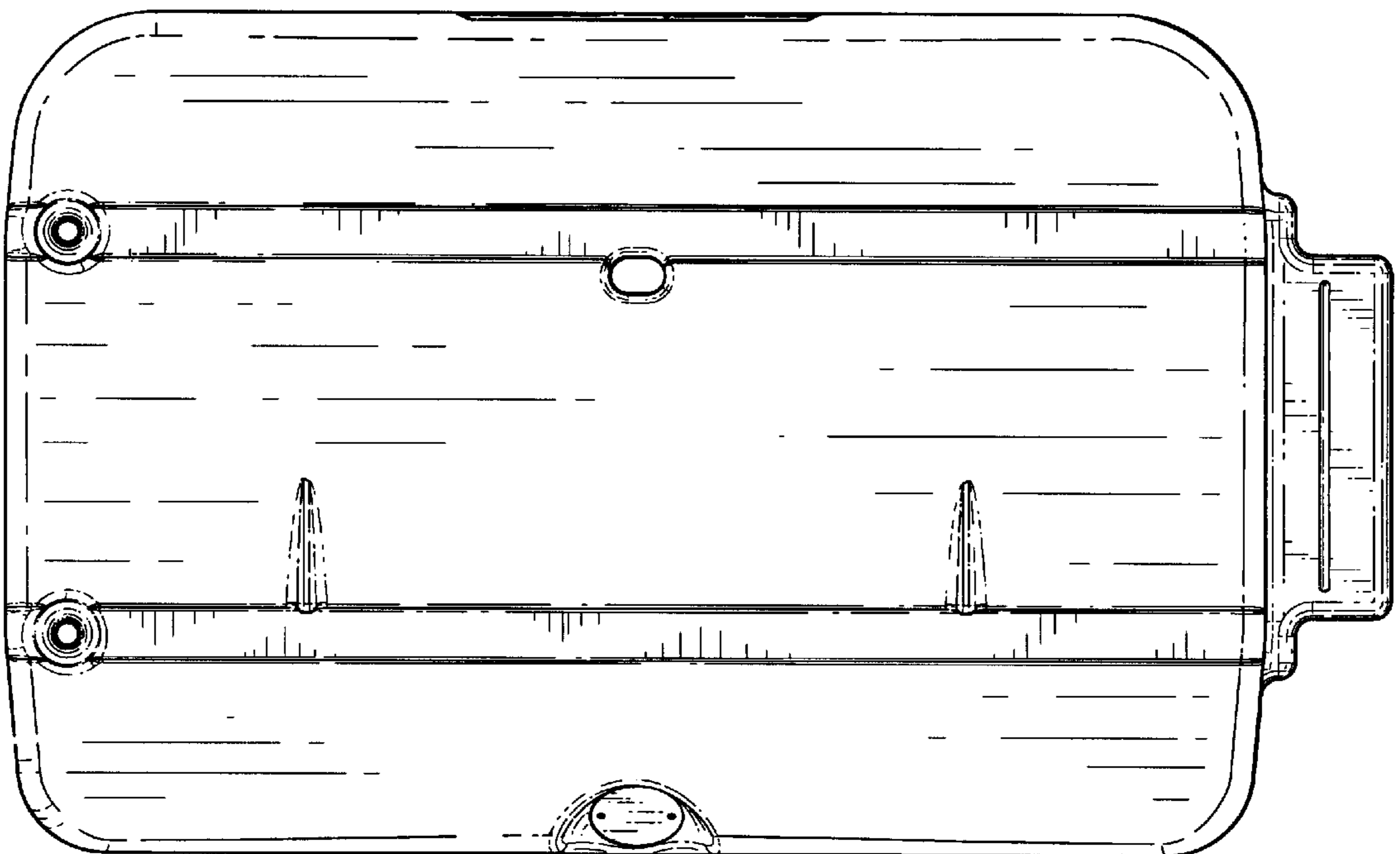

Fig. 11

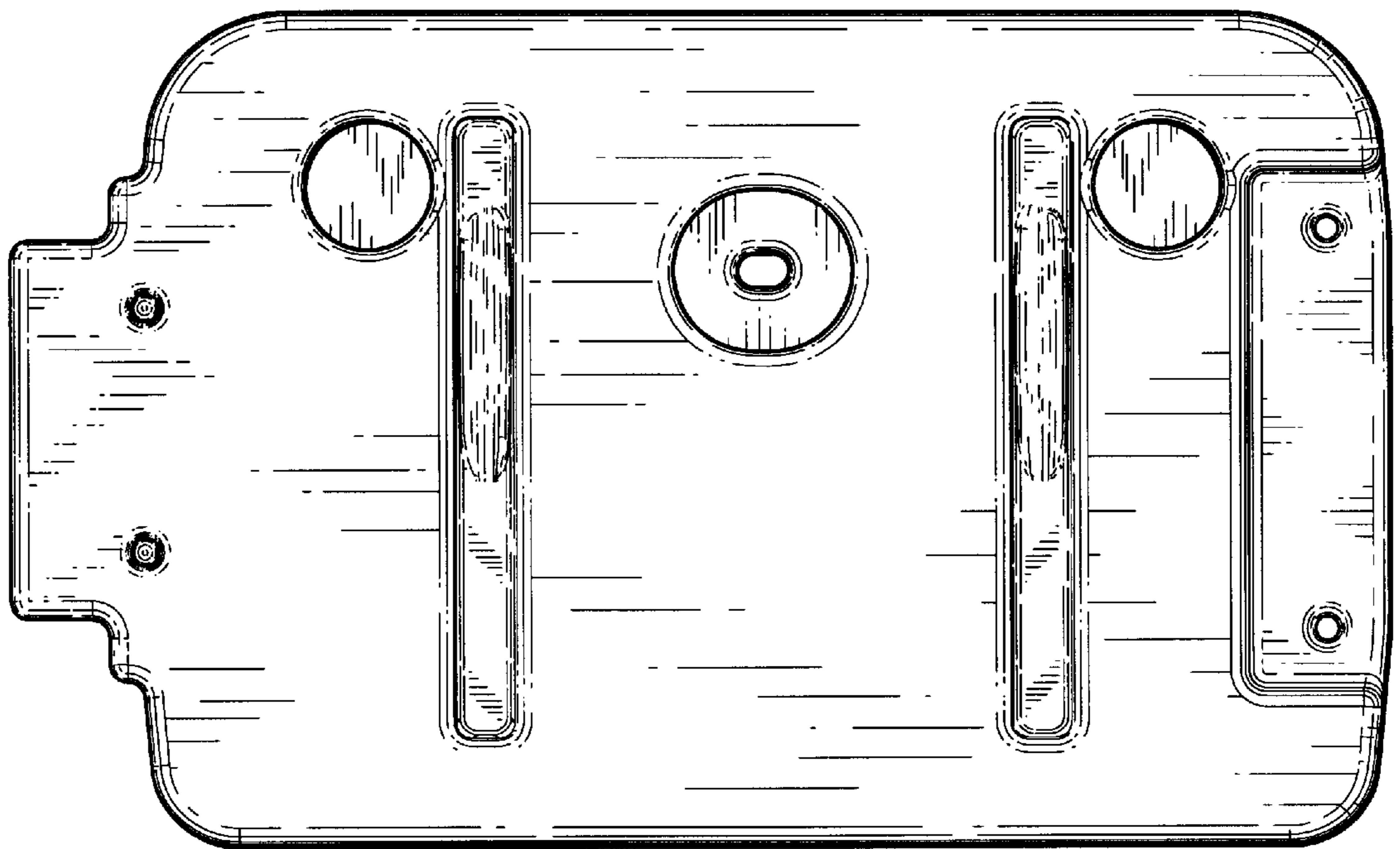

Fig. 12

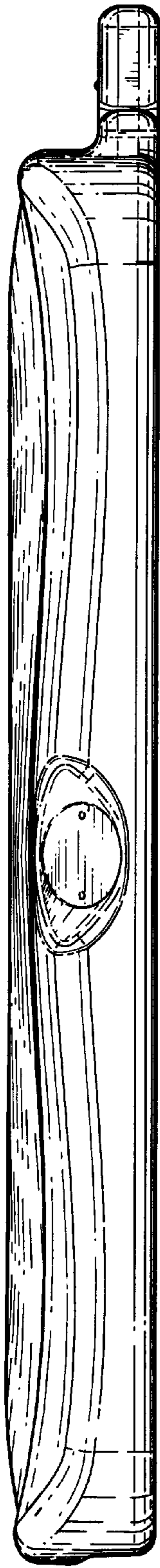

Fig. 13

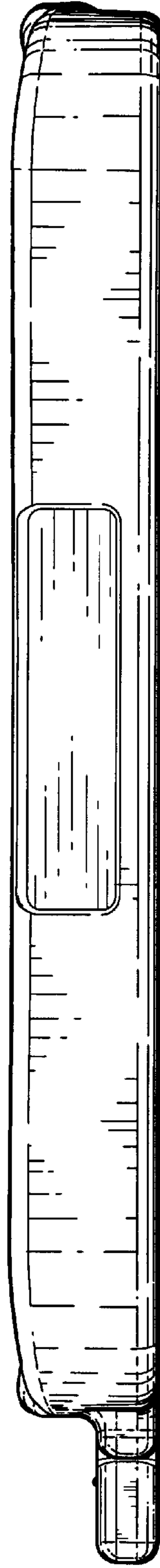

Fig. 14

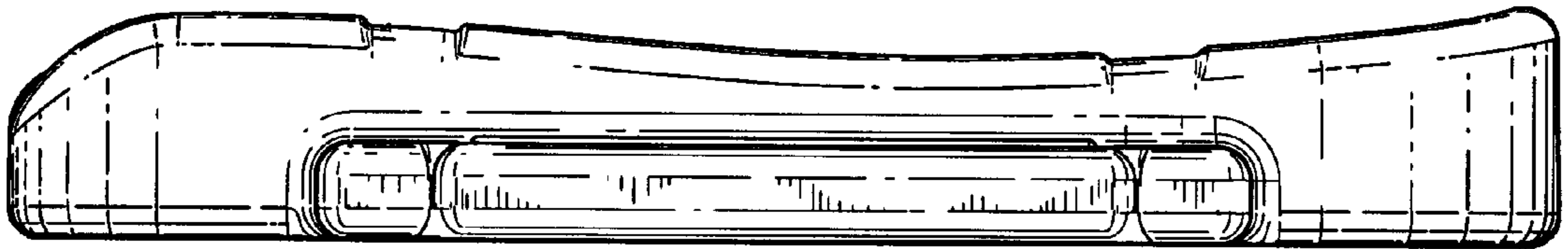

Fig. 15

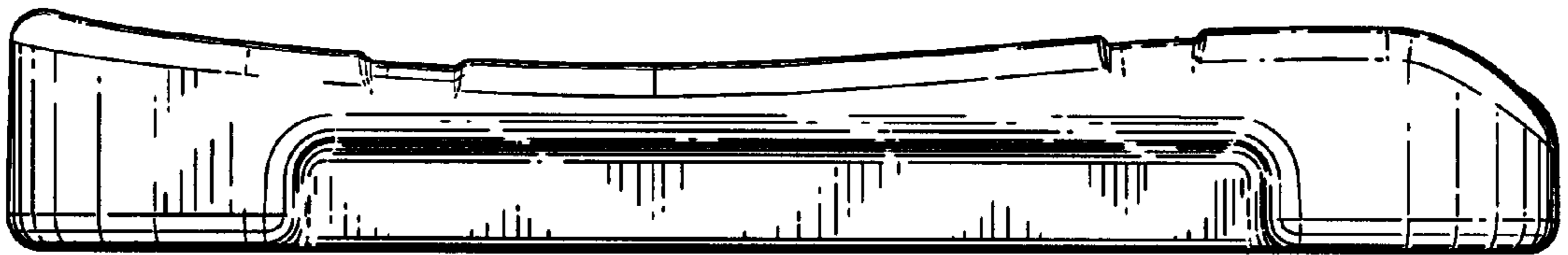

Fig. 16

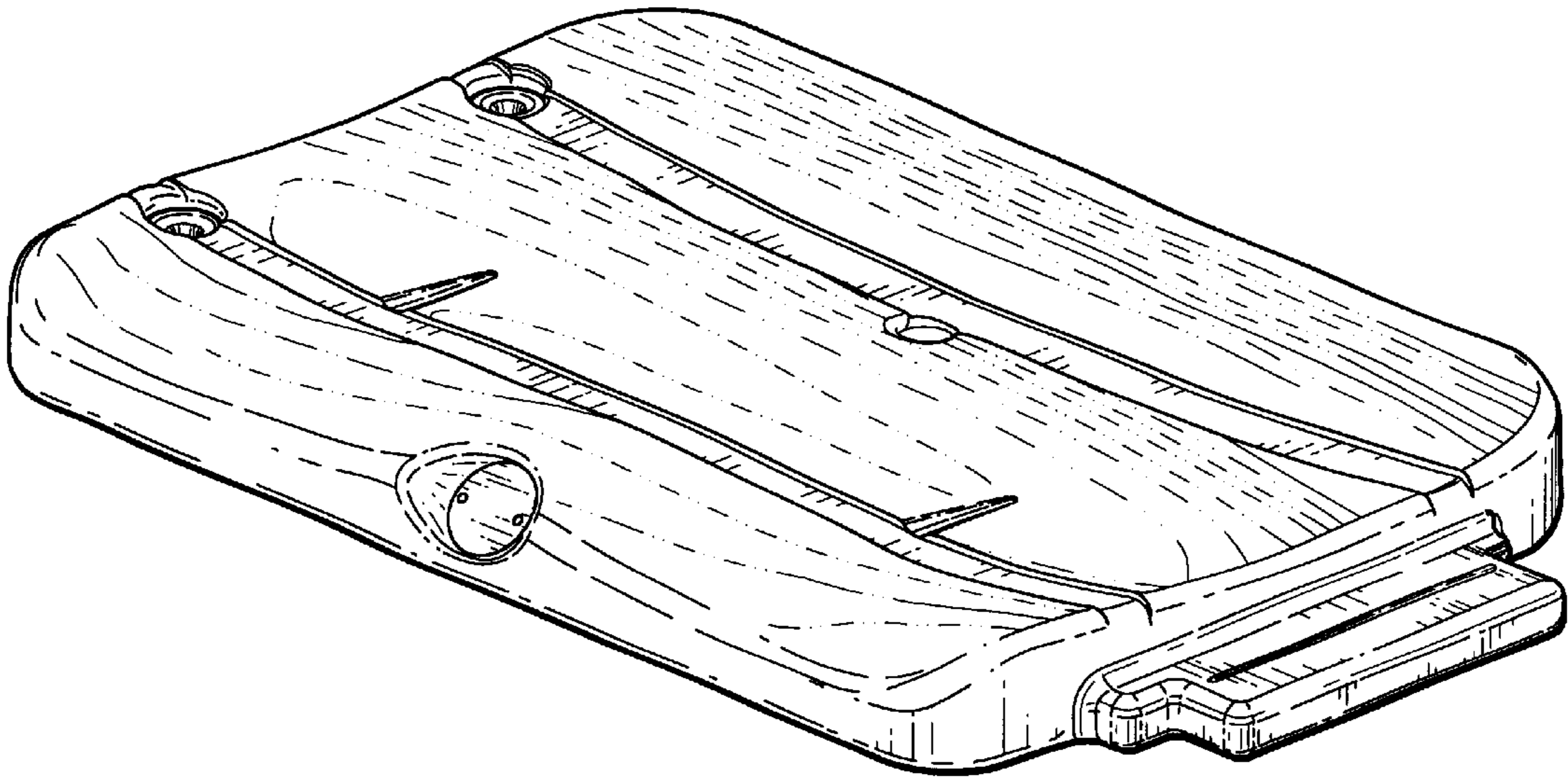

Fig. 17

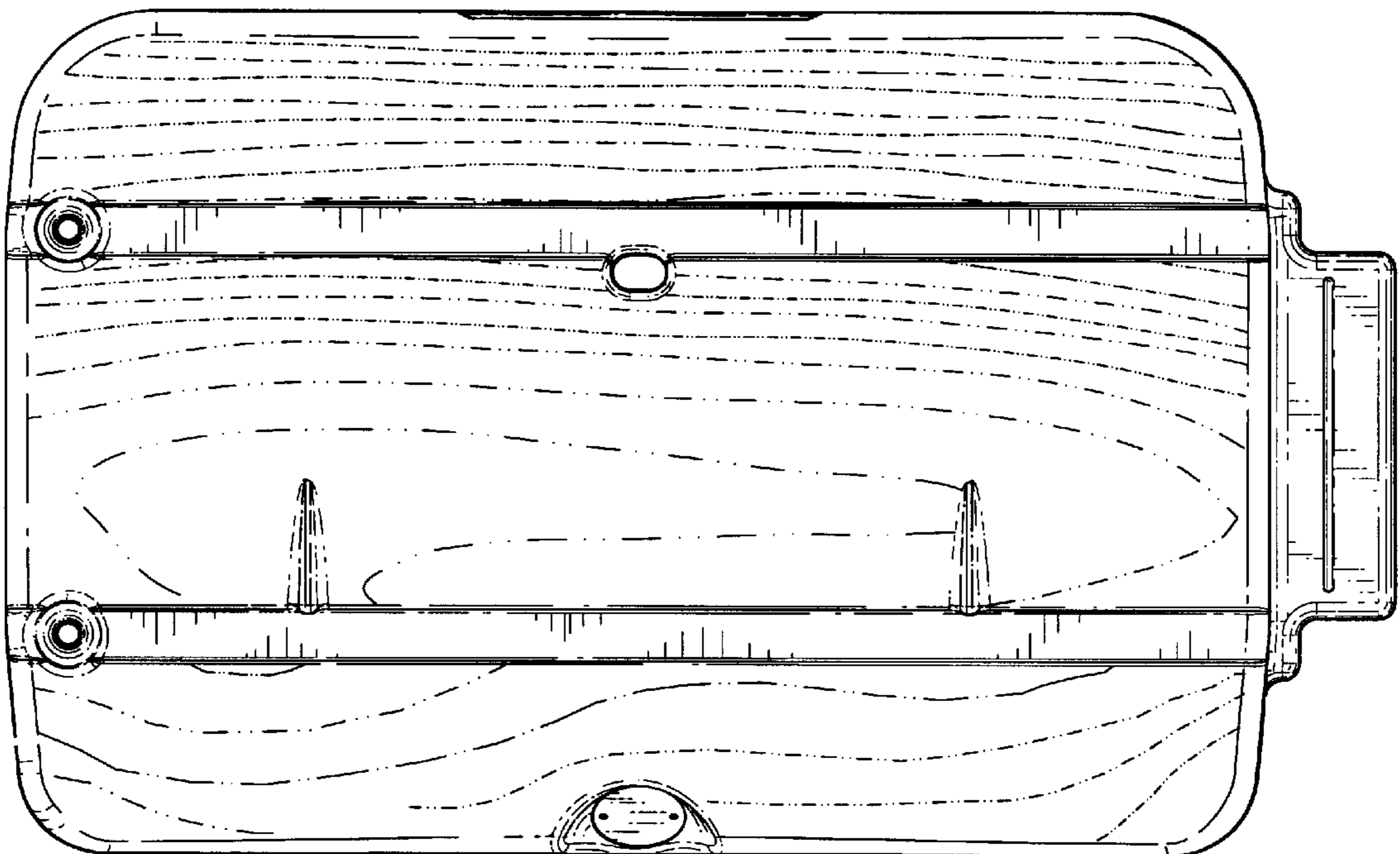

Fig. 18

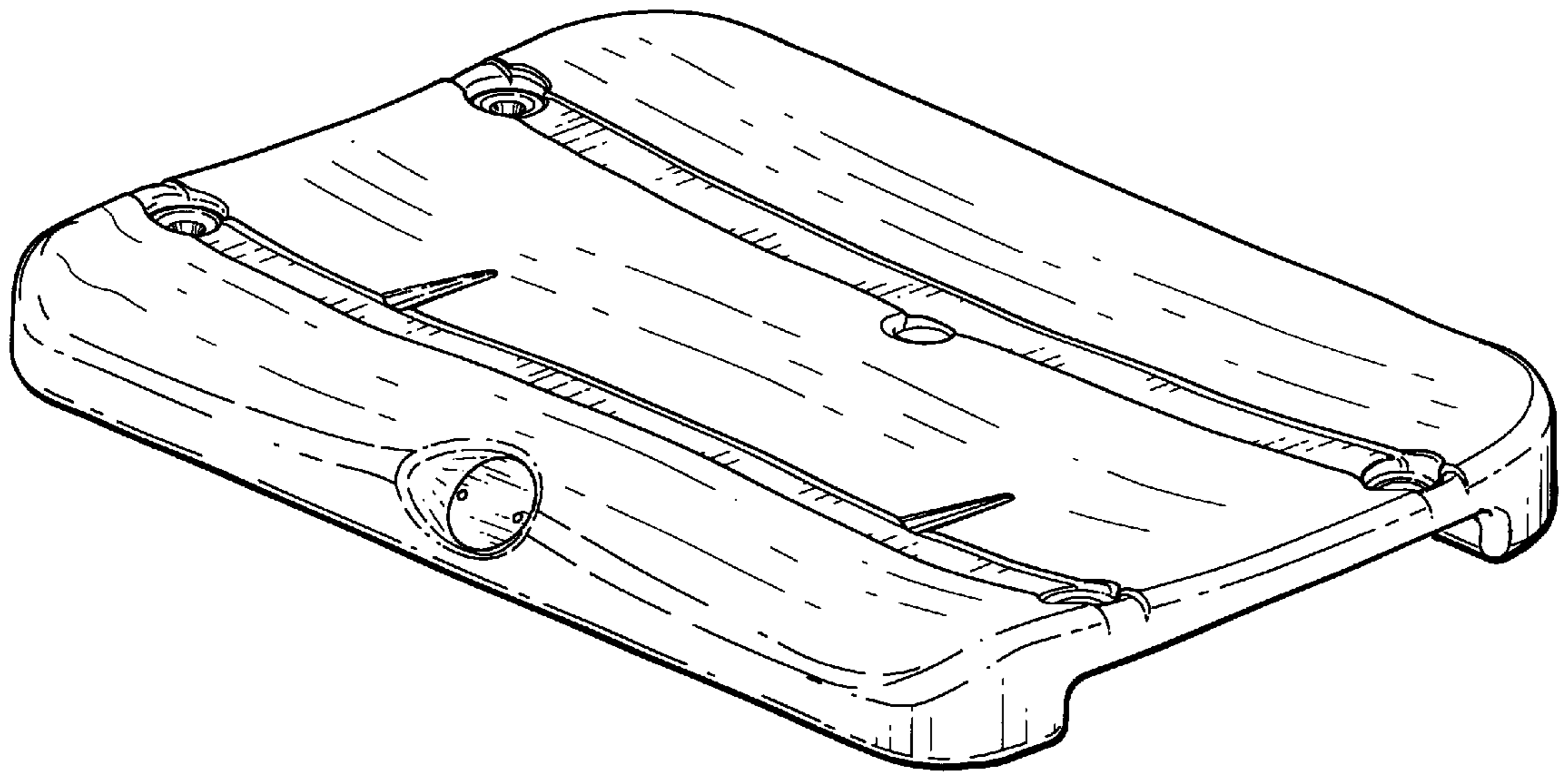

Fig. 19

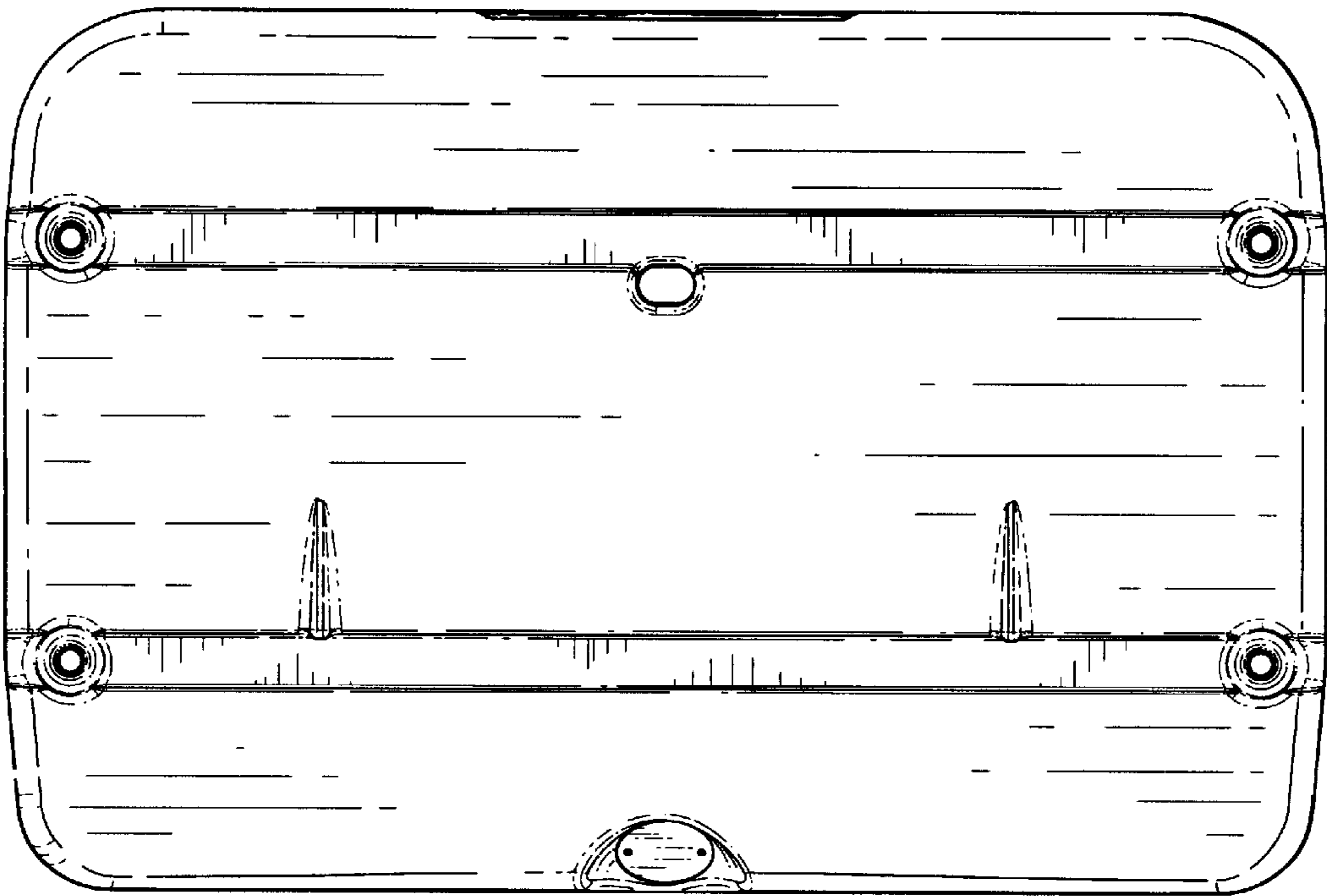

Fig. 20

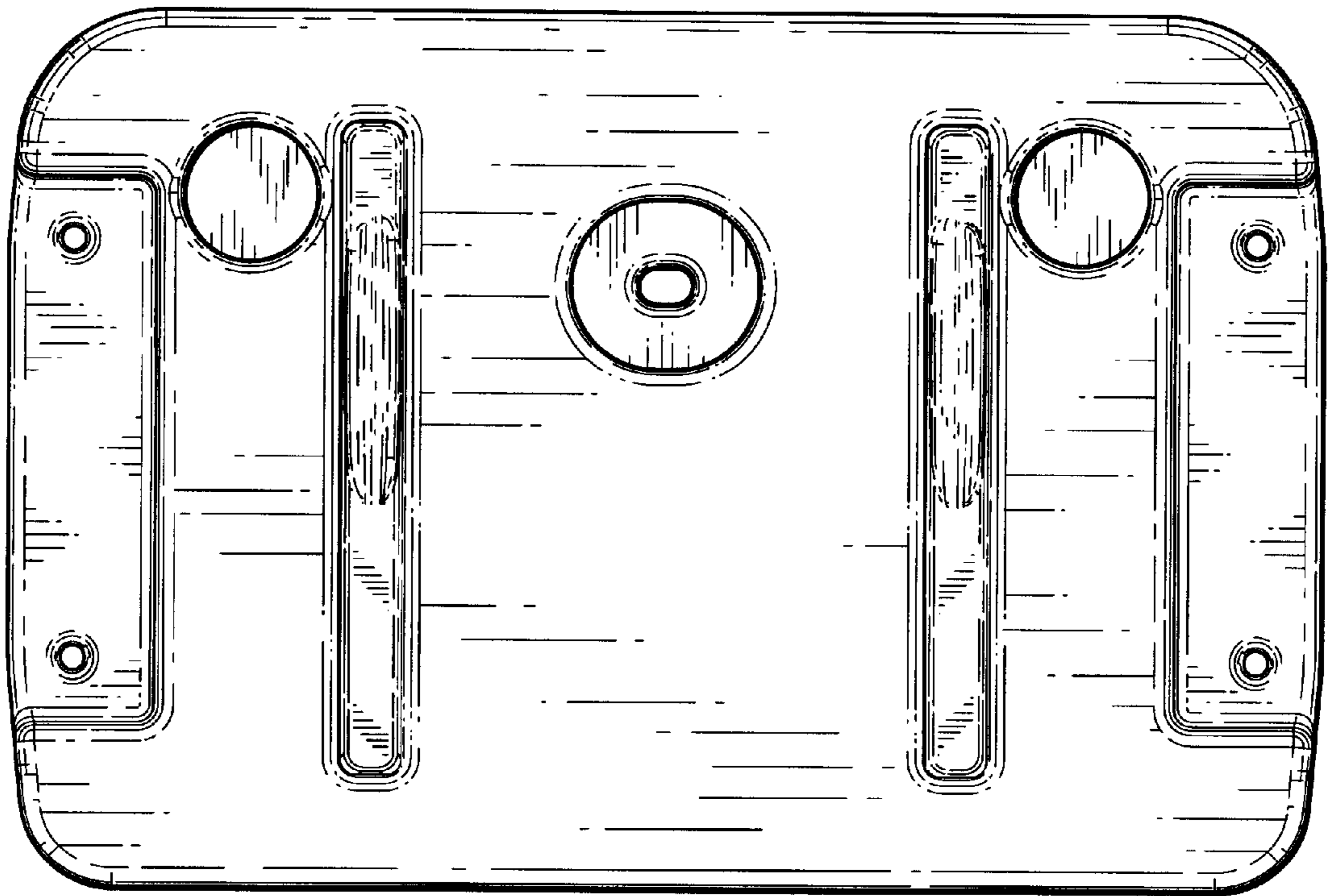

Fig. 21

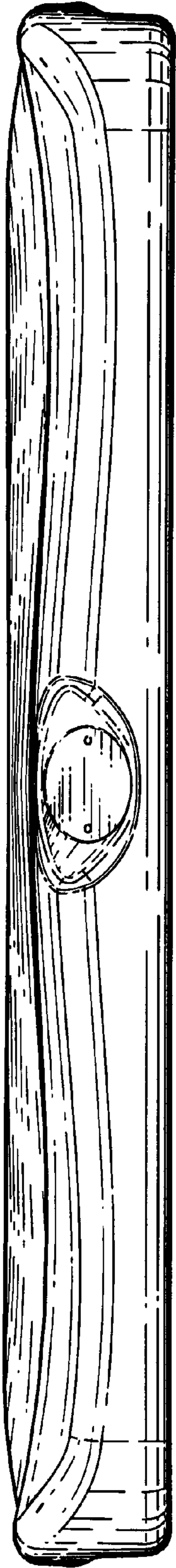

Fig. 22

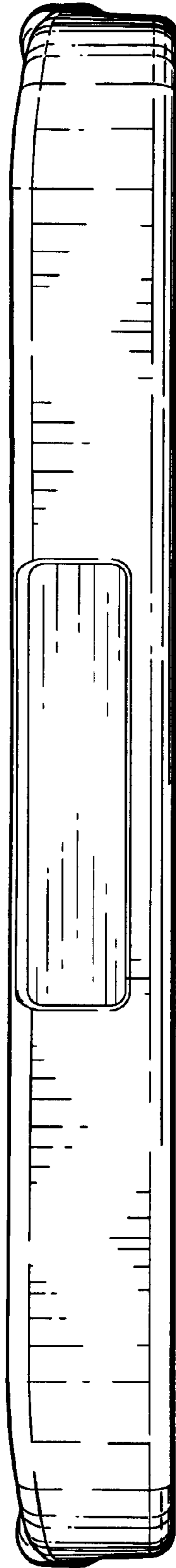

Fig. 23

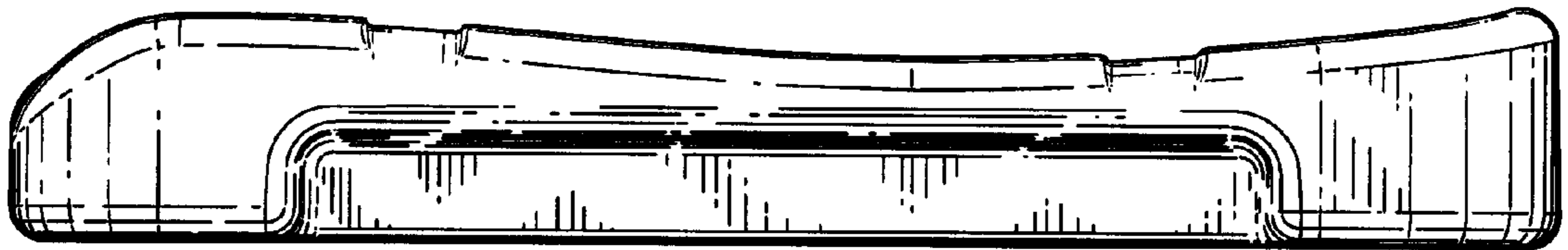

Fig. 24



Fig. 25

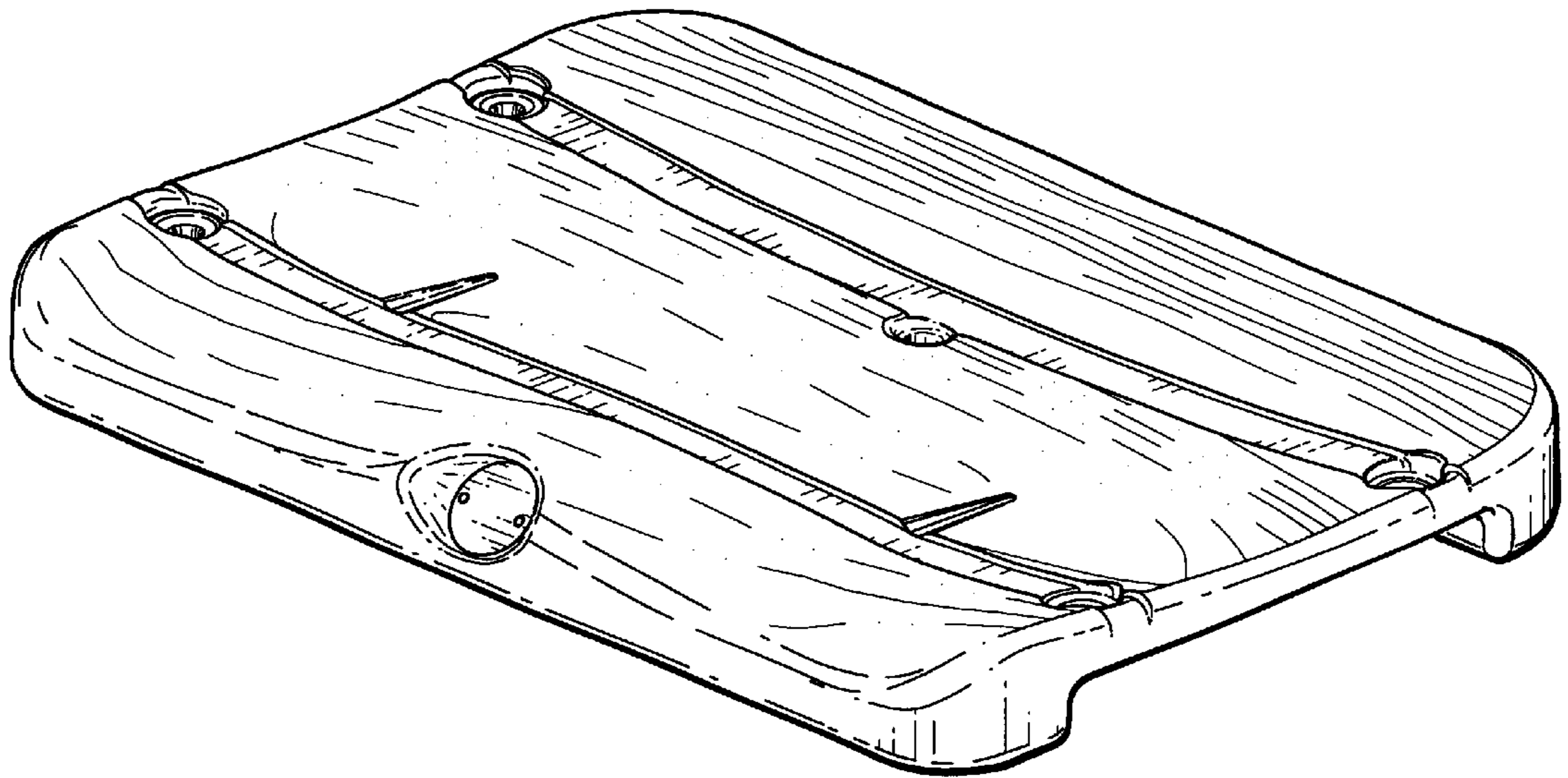

Fig. 26

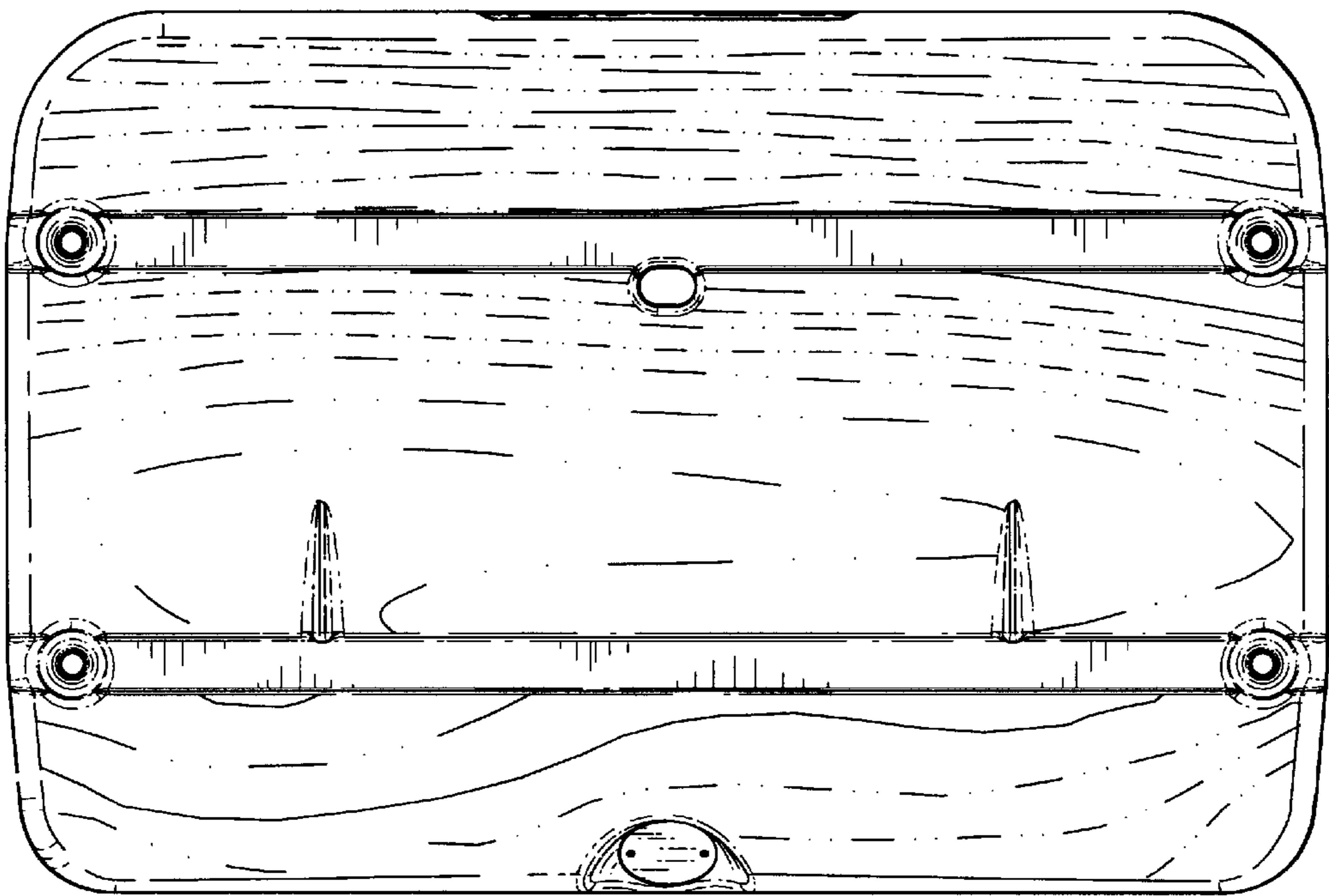

Fig. 27