



US00D446792B1

(12) **United States Design Patent**
Matthew et al.

(10) **Patent No.:** **US D446,792 S**

(45) **Date of Patent:** **** Aug. 21, 2001**

(54) **COMPRESSOR**

(75) Inventors: **Mark R. Matthew**, New Ulm, MN (US); **David McCoy**, Oswego, IL (US); **Tom Graber**, New Ulm, MN (US); **Richard Hawkes**, Naperville, IL (US); **Keith Kristiansen**, Statford, CT (US); **John Kiely**, Morris Plains, NJ (US); **Gary Grossman**, Riverside, CT (US); **Thomas C. Vandyk**, Ramsey, NJ (US)

(73) Assignee: **Coleman Powermate, Inc.**, Kearney, NE (US)

(**) Term: **14 Years**

(21) Appl. No.: **29/126,295**

(22) Filed: **Jul. 12, 2000**

(51) **LOC (7) Cl.** **15-02**

(52) **U.S. Cl.** **D15/9**

(58) **Field of Search** D15/7-9; 417/360, 417/362, 44.9, 233, 231, 234; 137/899.4, 565; 248/645, 675

D. 352,294	11/1994	Morgan .	
D. 352,295	11/1994	Morgan .	
D. 403,330	12/1998	Williams .	
D. 403,331	12/1998	Williams .	
D. 405,805	2/1999	Rock .	
D. 407,413	3/1999	Wang .	
D. 409,206	5/1999	Wang .	
D. 422,603	4/2000	DeYoung .	
D. 423,518	4/2000	Milligan .	
1,730,319	10/1929	Dilks .	
1,846,655	2/1932	Rayfield .	
2,136,098	11/1938	Browne .	
2,384,174	* 9/1945	Jones	222/3
2,804,259	8/1957	Ralston .	
4,077,747	* 3/1978	Burenga	417/234
4,722,673	* 2/1988	Grimes et al.	417/360

* cited by examiner

Primary Examiner—Ralf Seifert

(74) *Attorney, Agent, or Firm*—Kramer, Levin, Naftalis & Frankel LLP

(57) **CLAIM**

The ornamental design for a compressor, as shown and described.

DESCRIPTION

FIG. 1 is perspective view showing the new design; FIG. 2 is a front elevation view thereof; FIG. 3 is a rear elevation view thereof; FIG. 4 is a side elevation view thereof; FIG. 5 is a side elevation view thereof, showing the opposite side of FIG. 4; FIG. 6 is a top plan view thereof; and, FIG. 7 is a bottom plan view thereof. The broken lines shown in the drawings identify environmental structure or boundaries that form no part of the design to be patented.

1 Claim, 7 Drawing Sheets

(56) **References Cited**

U.S. PATENT DOCUMENTS

D. 144,482	4/1946	Davis et al. .	
D. 156,075	11/1949	Collier .	
D. 185,000	* 4/1959	Hoover	D15/9
D. 223,039	* 2/1972	Widmer	D15/7
D. 243,282	2/1977	Burenga .	
D. 273,011	3/1984	Dudley .	
D. 273,493	* 4/1984	Vitaloni	D15/9
D. 293,446	12/1987	Morgan .	
D. 293,584	1/1988	Morgan .	
D. 293,585	1/1988	Morgan .	
D. 332,613	1/1993	Keller .	
D. 352,292	11/1994	Morgan .	
D. 352,293	11/1994	Morgan .	

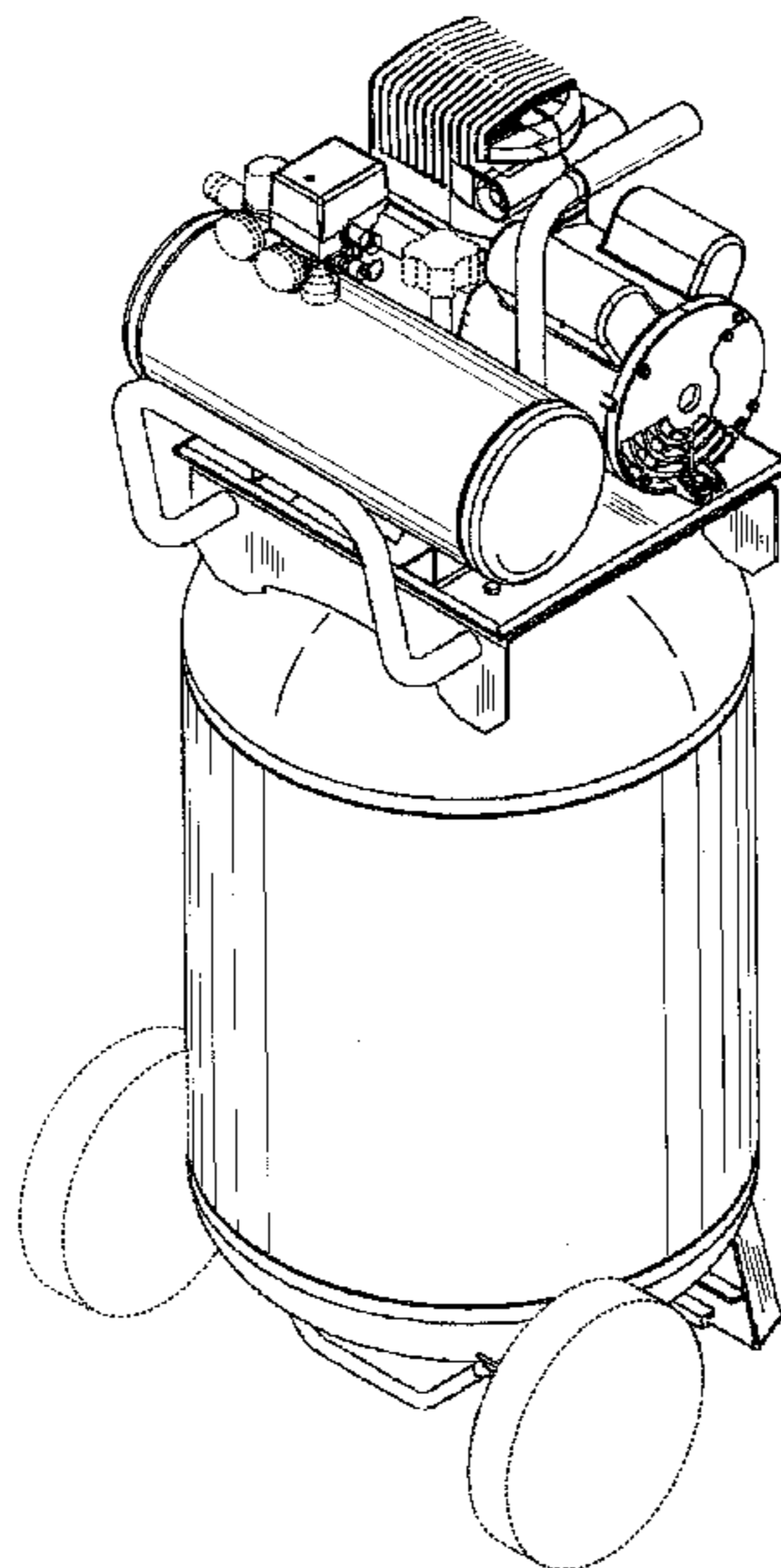

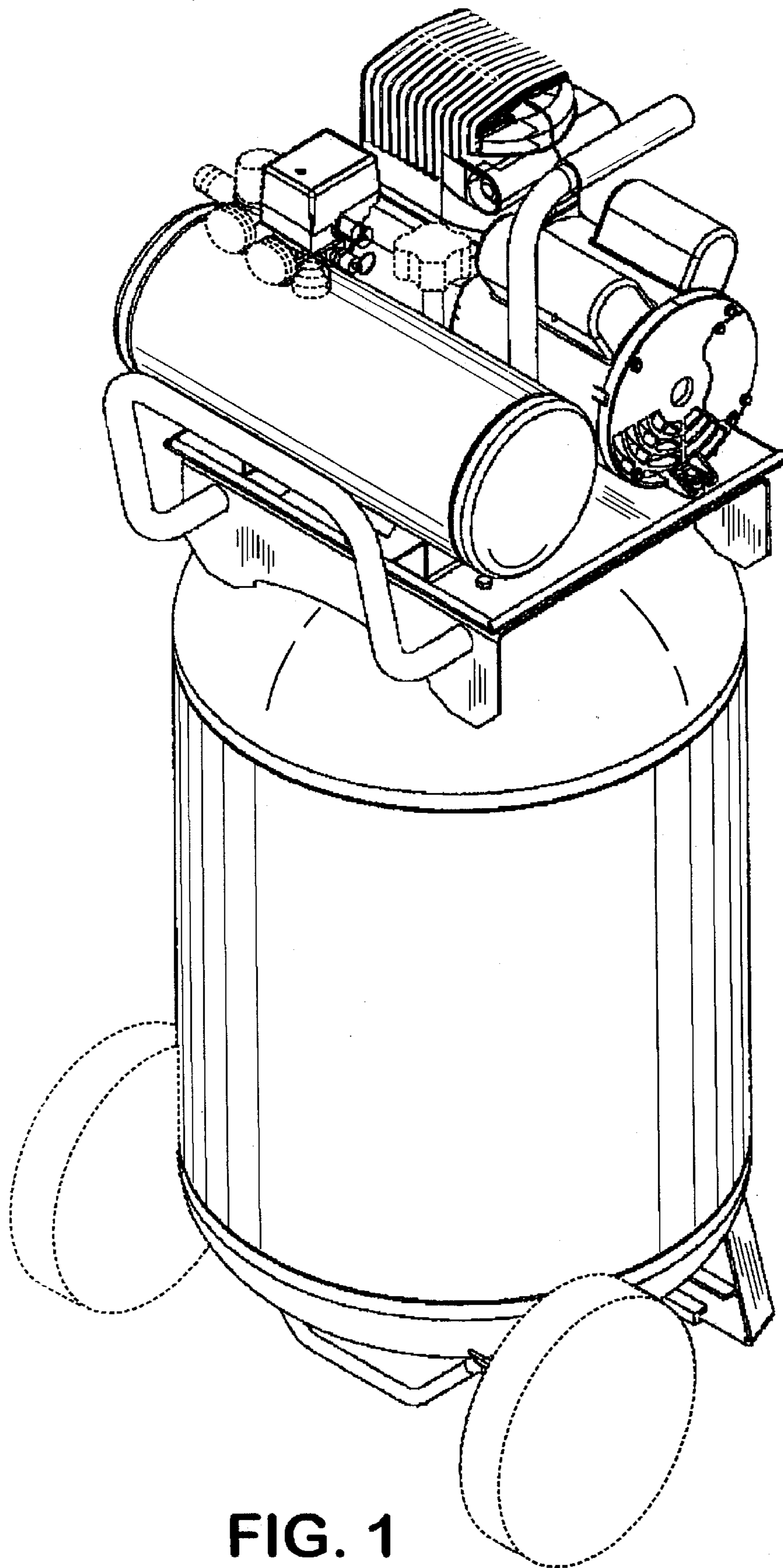

FIG. 1

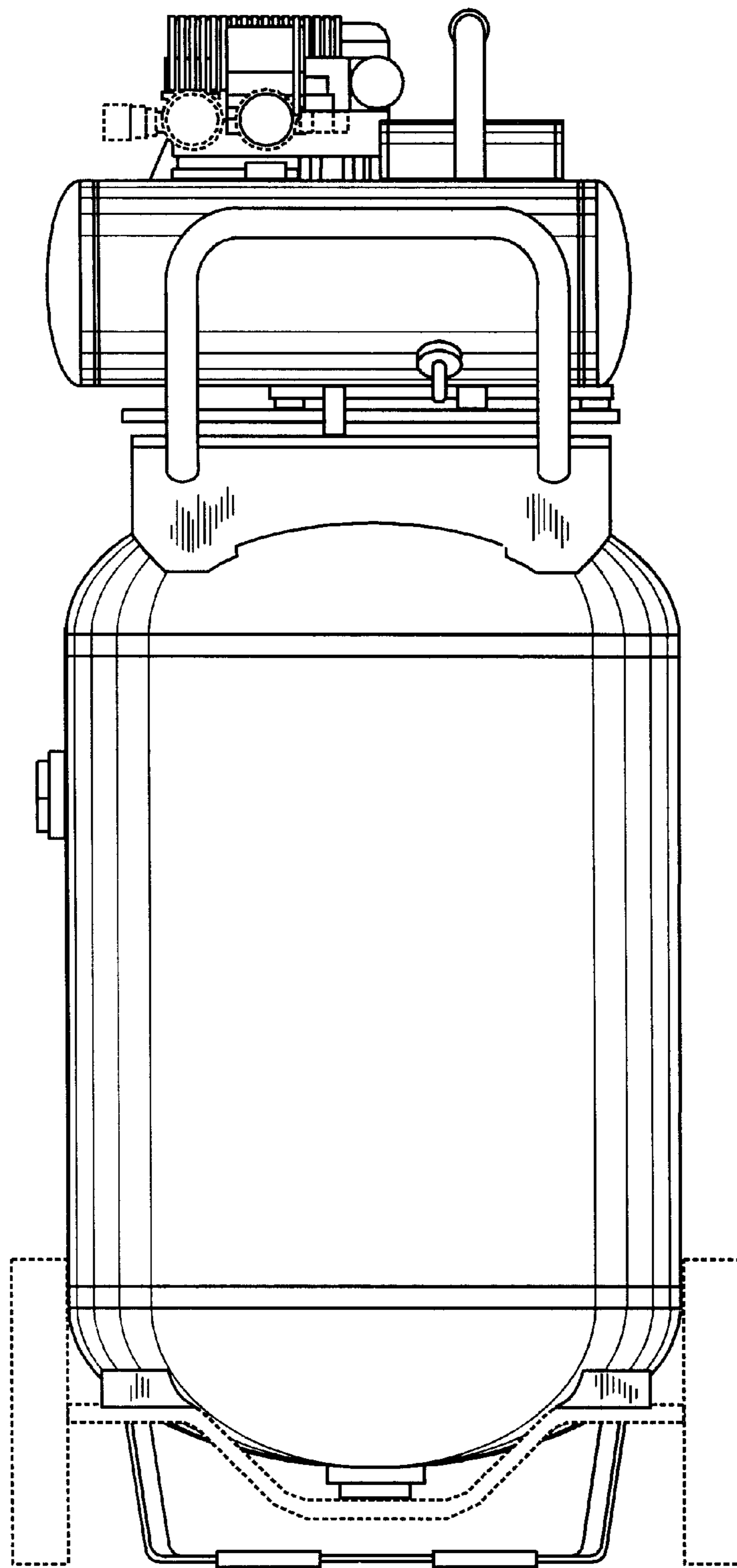

FIG. 2

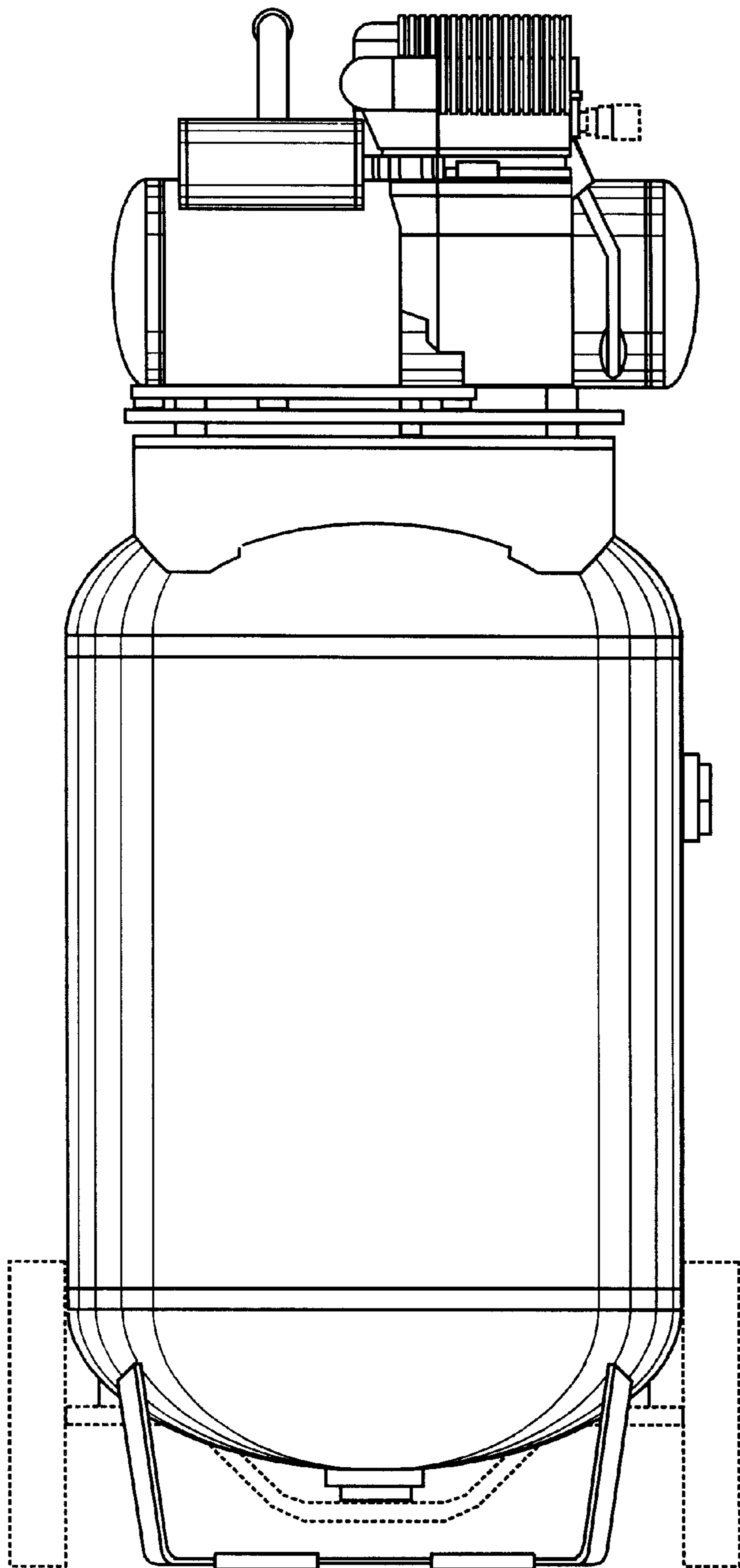

FIG. 3

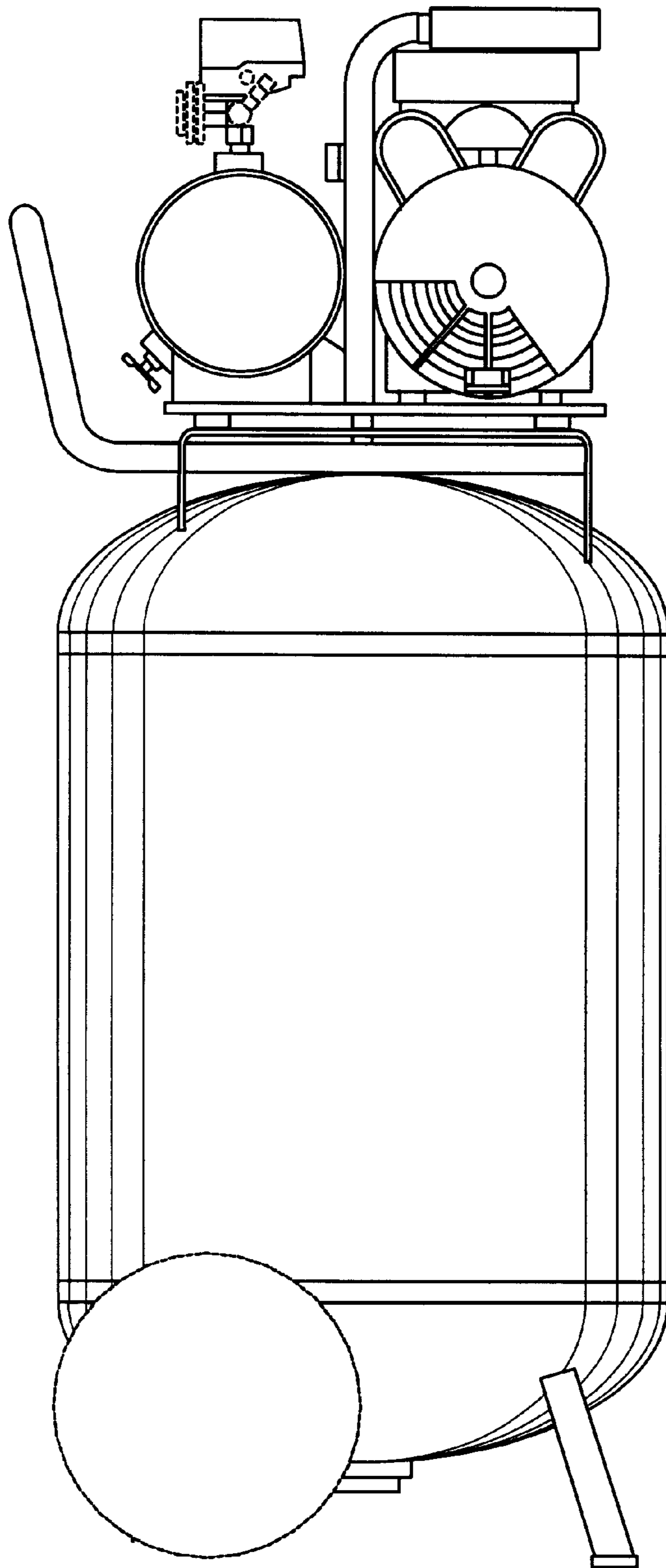

FIG. 4

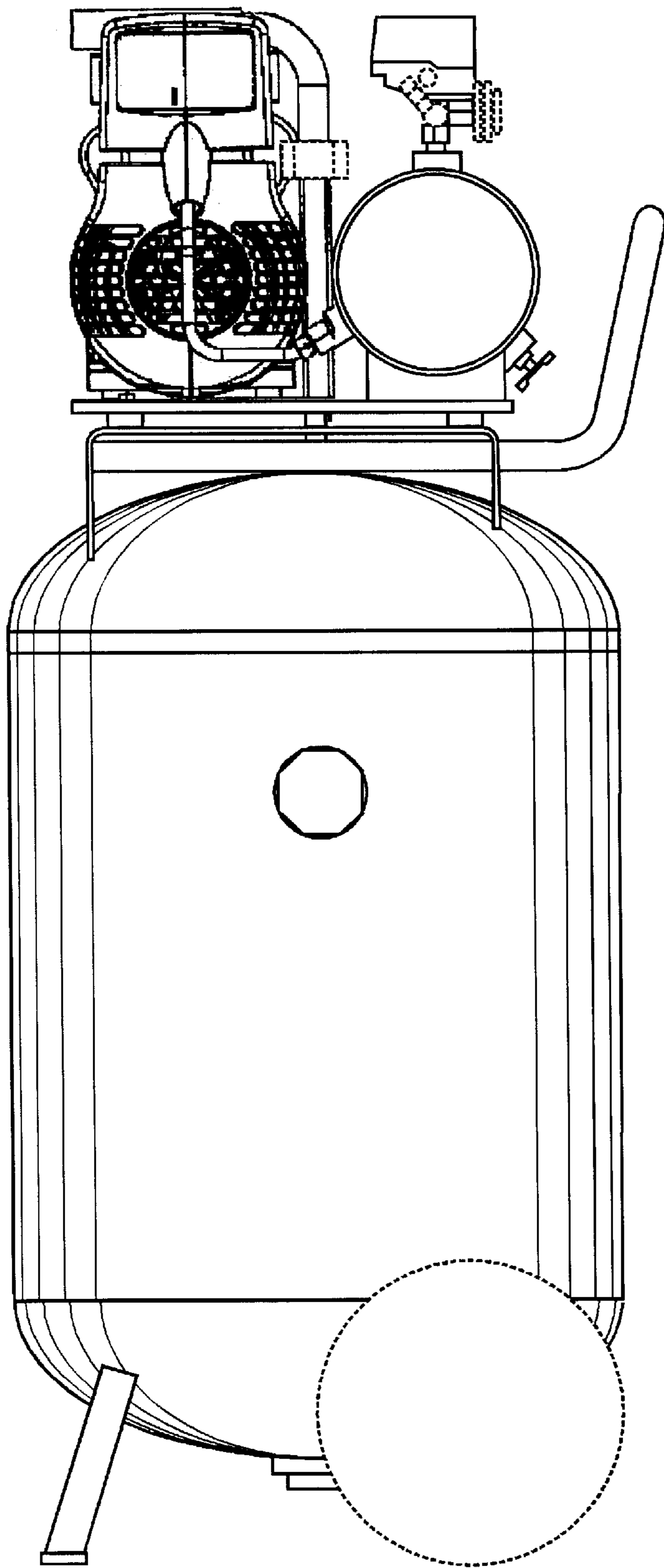

FIG. 5

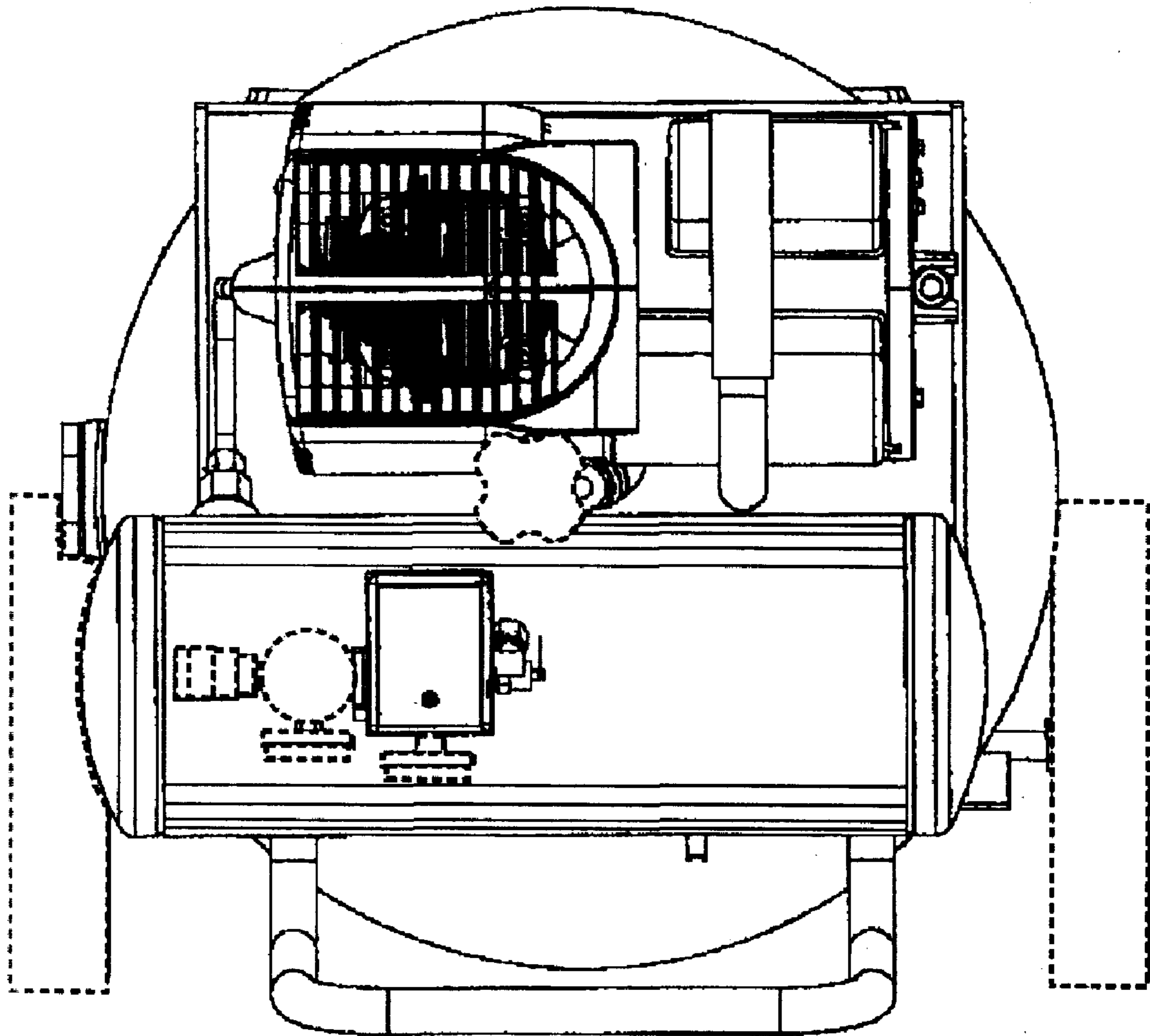

FIG. 6

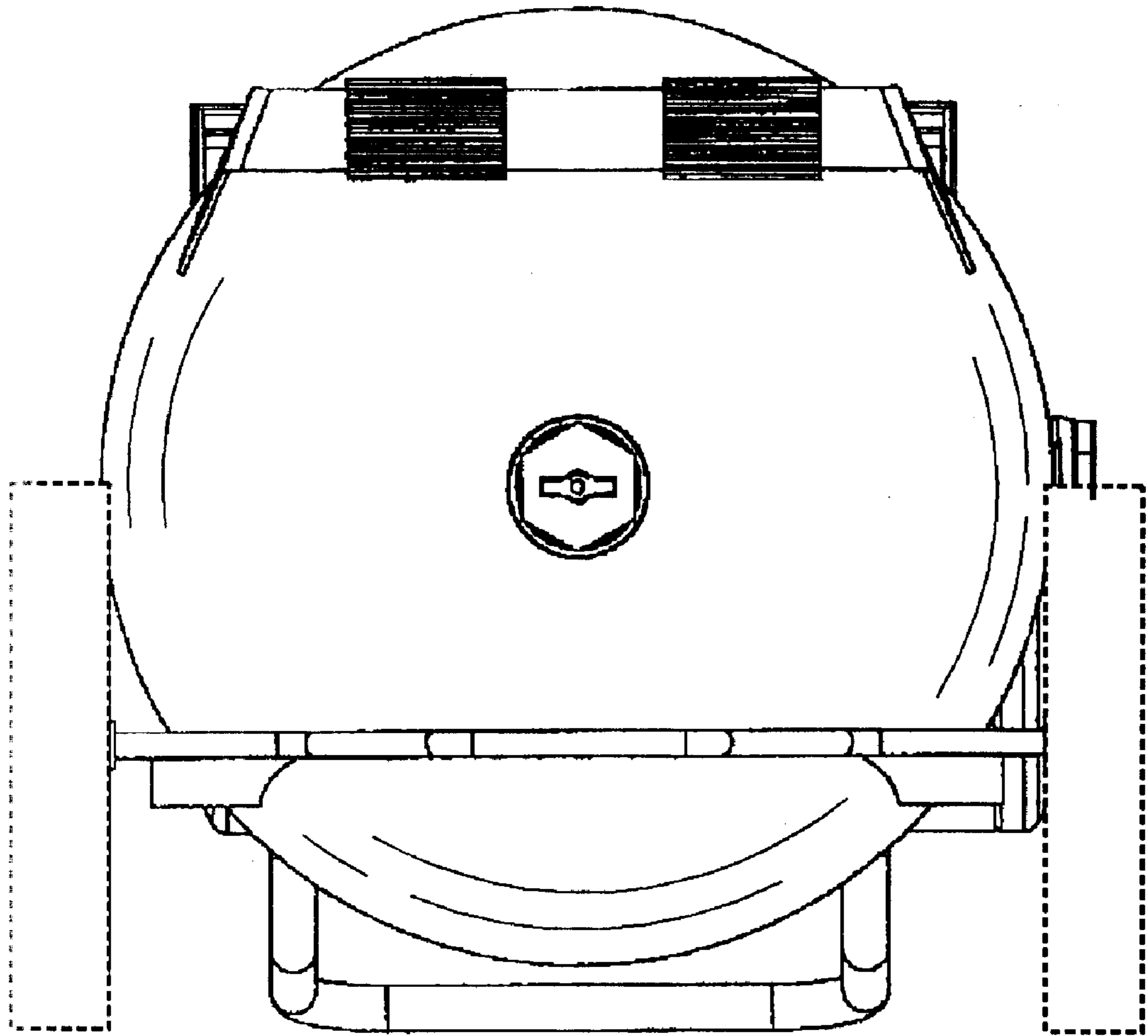

FIG. 7