



US00D446778B1

(12) **United States Design Patent**  
**Feucht**

(10) **Patent No.:** **US D446,778 S**

(45) **Date of Patent:** **\*\* Aug. 21, 2001**

(54) **ENCLOSURE FOR A SPEAKER CABLE CONNECTOR**

(75) Inventor: **Christian C. Feucht**, Nevada City, CA (US)

(73) Assignee: **Constant Velocity Transmission Lines, Inc.**, Rocklin, CA (US)

(\*\*) Term: **14 Years**

(21) Appl. No.: **29/118,949**

(22) Filed: **Feb. 17, 2000**

(51) **LOC (7) Cl.** ..... **13-03**

(52) **U.S. Cl.** ..... **D13/154; D13/151; D13/133**

(58) **Field of Search** ..... **D13/133, 151, D13/154; 439/394, 578, 583**

(56) **References Cited**

**U.S. PATENT DOCUMENTS**

D. 249,139	*	8/1978	Lin	.....	D13/151	X
D. 400,854	*	11/1998	Beranek	.....	D13/133	
D. 425,487	*	5/2000	Lee	.....	D13/133	X
5,810,620	*	9/1998	Kobayashi et al.	.....	439/610	
5,879,196	*	3/1999	Lee	.....	439/660	

\* cited by examiner

*Primary Examiner*—Joel Sincavage

(74) *Attorney, Agent, or Firm*—Sierra Patent Group, Ltd.

(57) **CLAIM**

The ornamental design for an enclosure for a speaker cable connector, as shown and described.

**DESCRIPTION**

FIG. 1 is a top view of an enclosure for a speaker cable connector showing my new design in full lines with the broken lines showing environmental association matter being for illustrative purposes only and forming no part of my design. The bottom view is a mirror image of the top view;

FIG. 2 shows a side view thereof in full lines and environmental association matter in broken lines;

FIG. 3 shows a side view thereof in full lines and environmental association matter in broken lines;

FIG. 4 shows an end view thereof in full lines and environmental association matter in broken lines;

FIG. 5 shows an end view thereof in full lines and environmental association matter in broken lines; and,

FIG. 6 is a perspective view thereof shown in full lines and environmental association matter in broken lines.

**1 Claim, 6 Drawing Sheets**

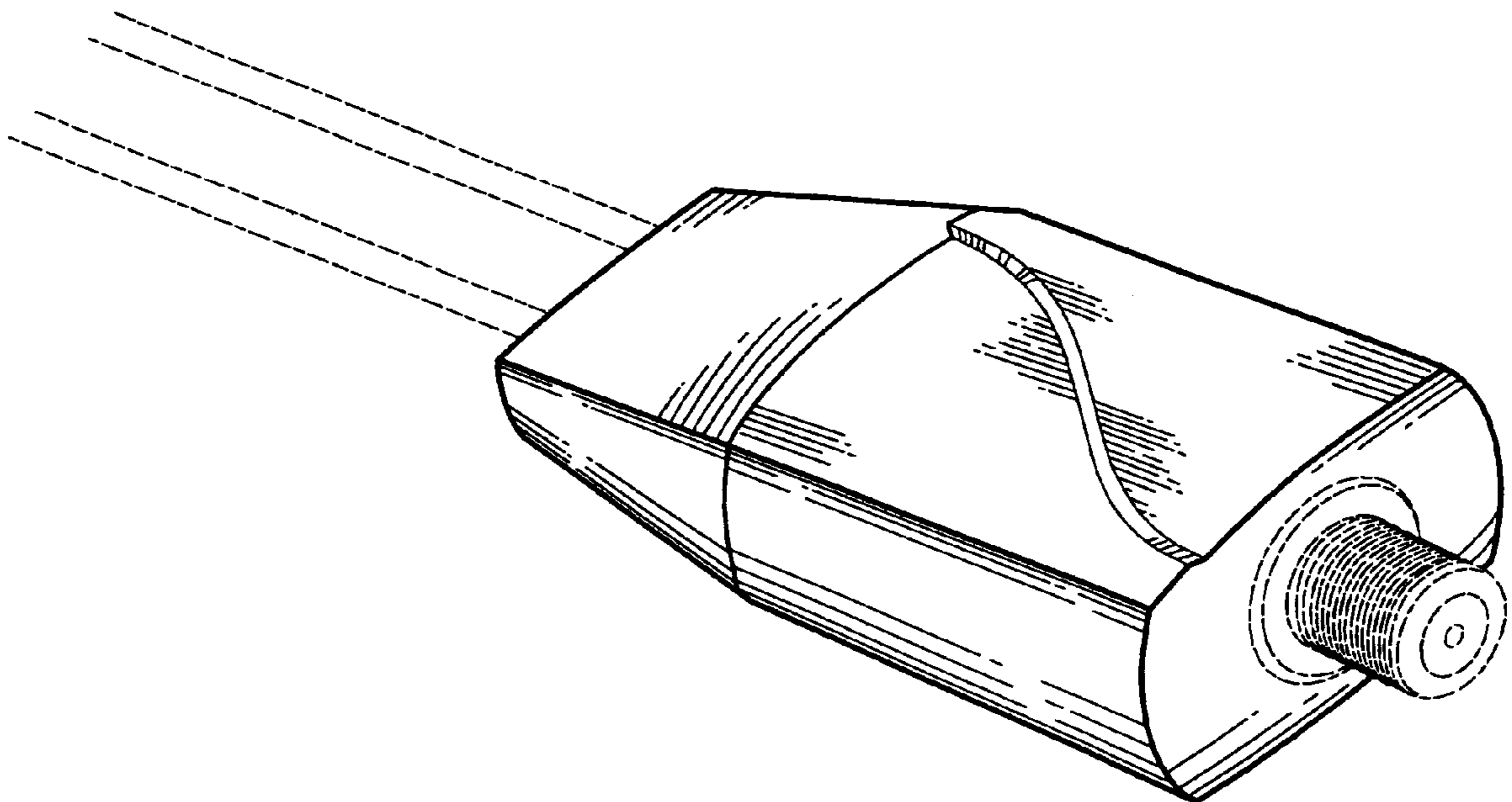

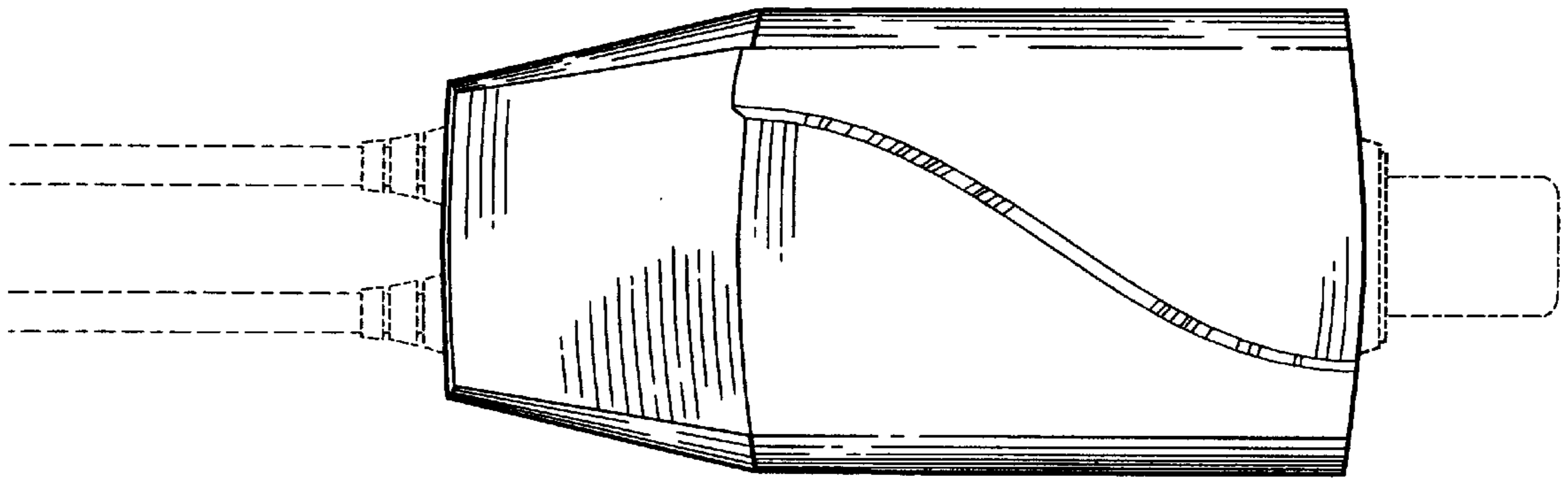

Fig. 1

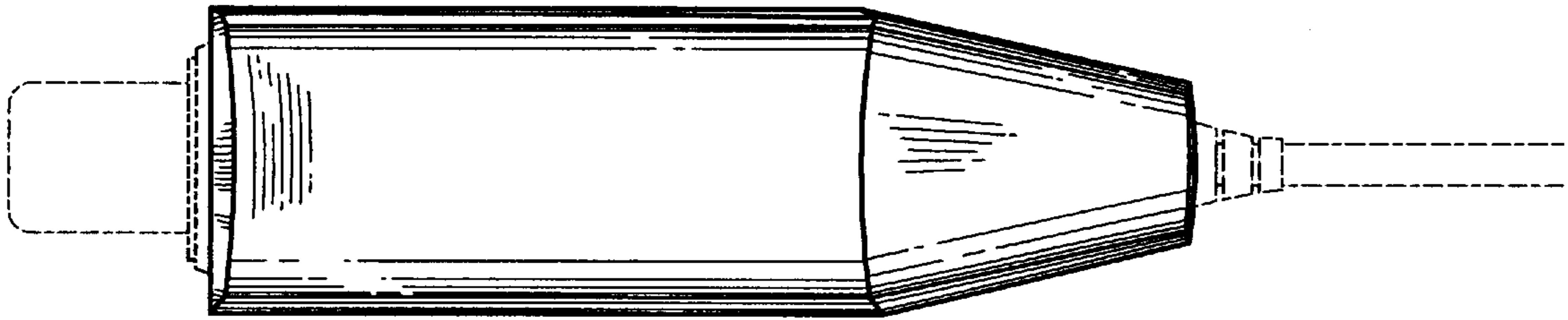

Fig. 2

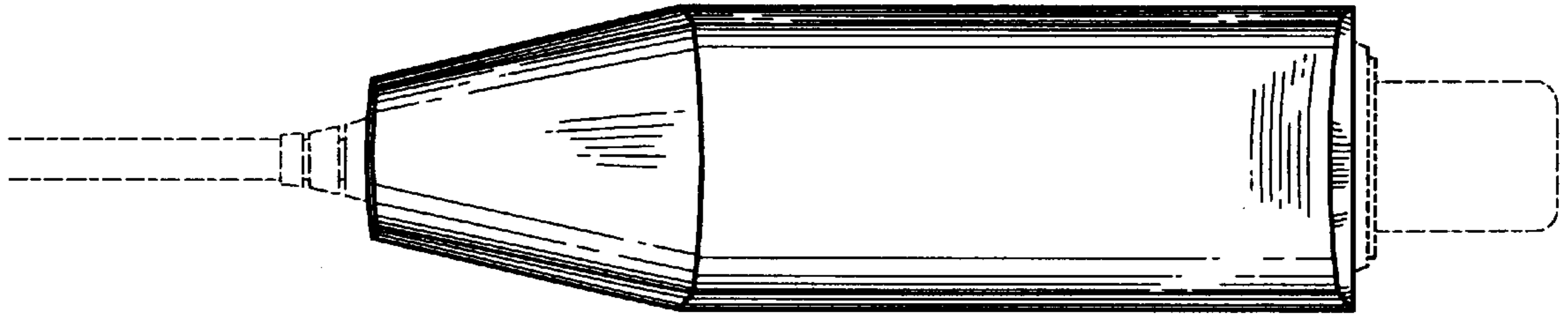
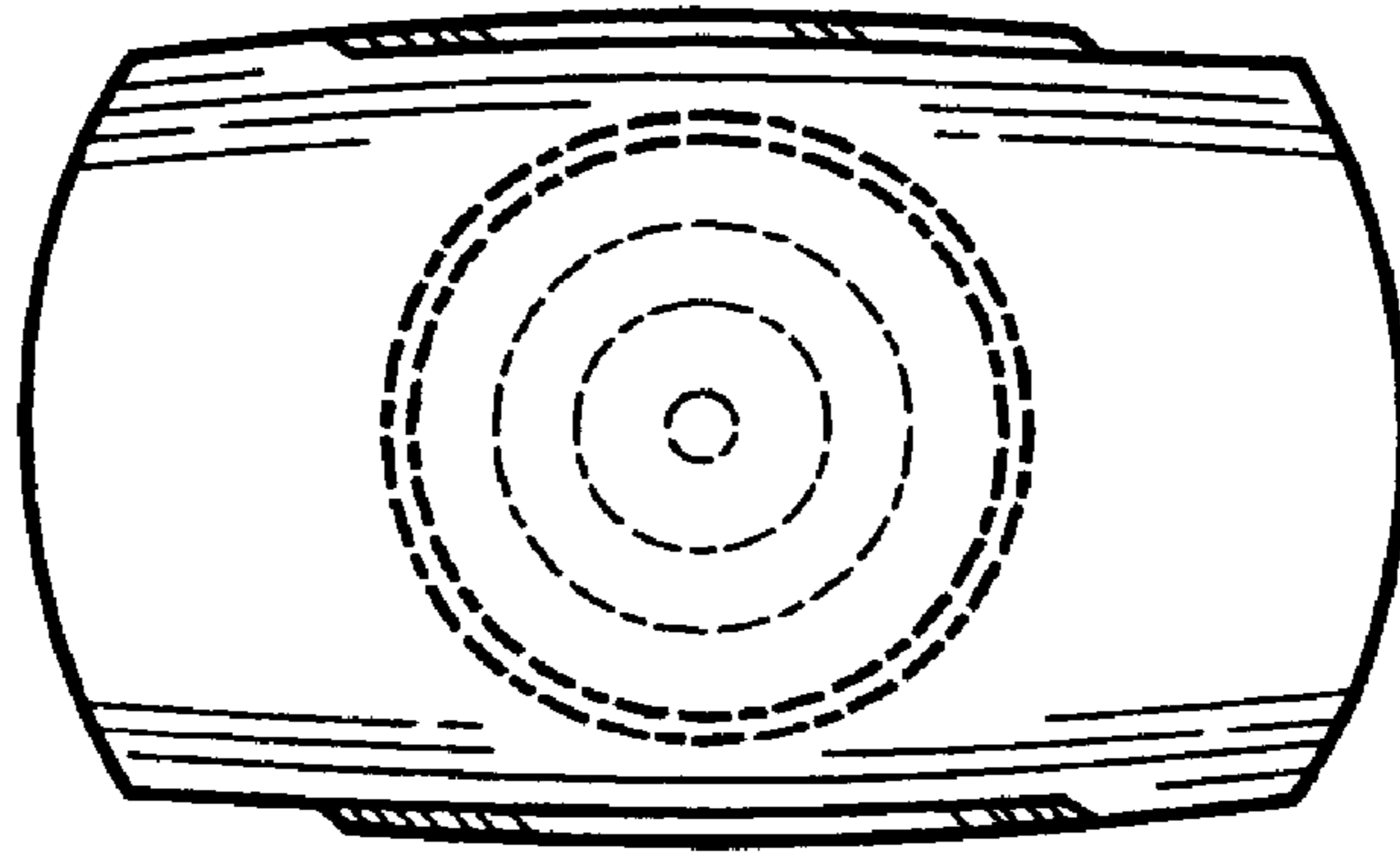
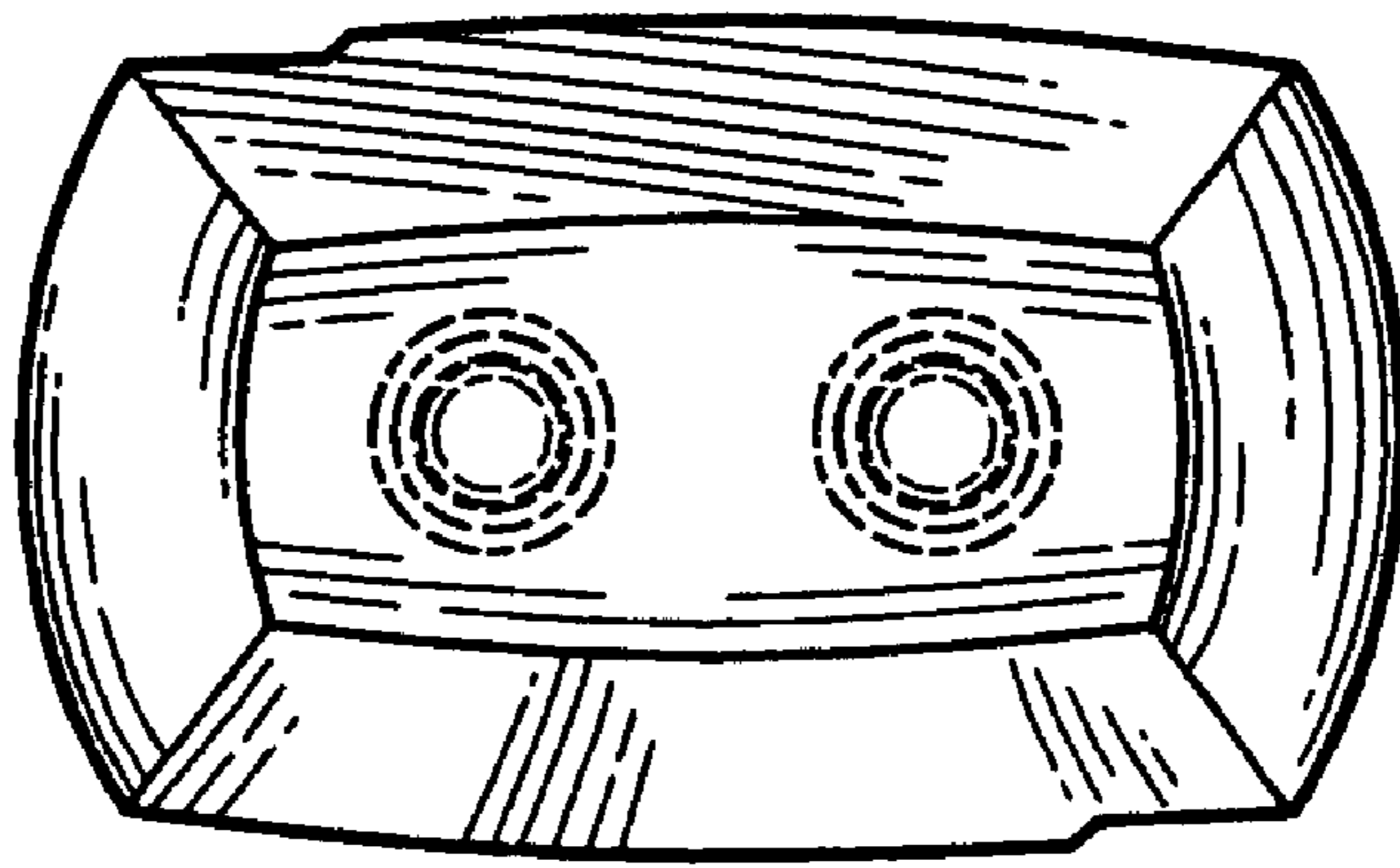

Fig. 3



**Fig. 4**



**Fig. 5**

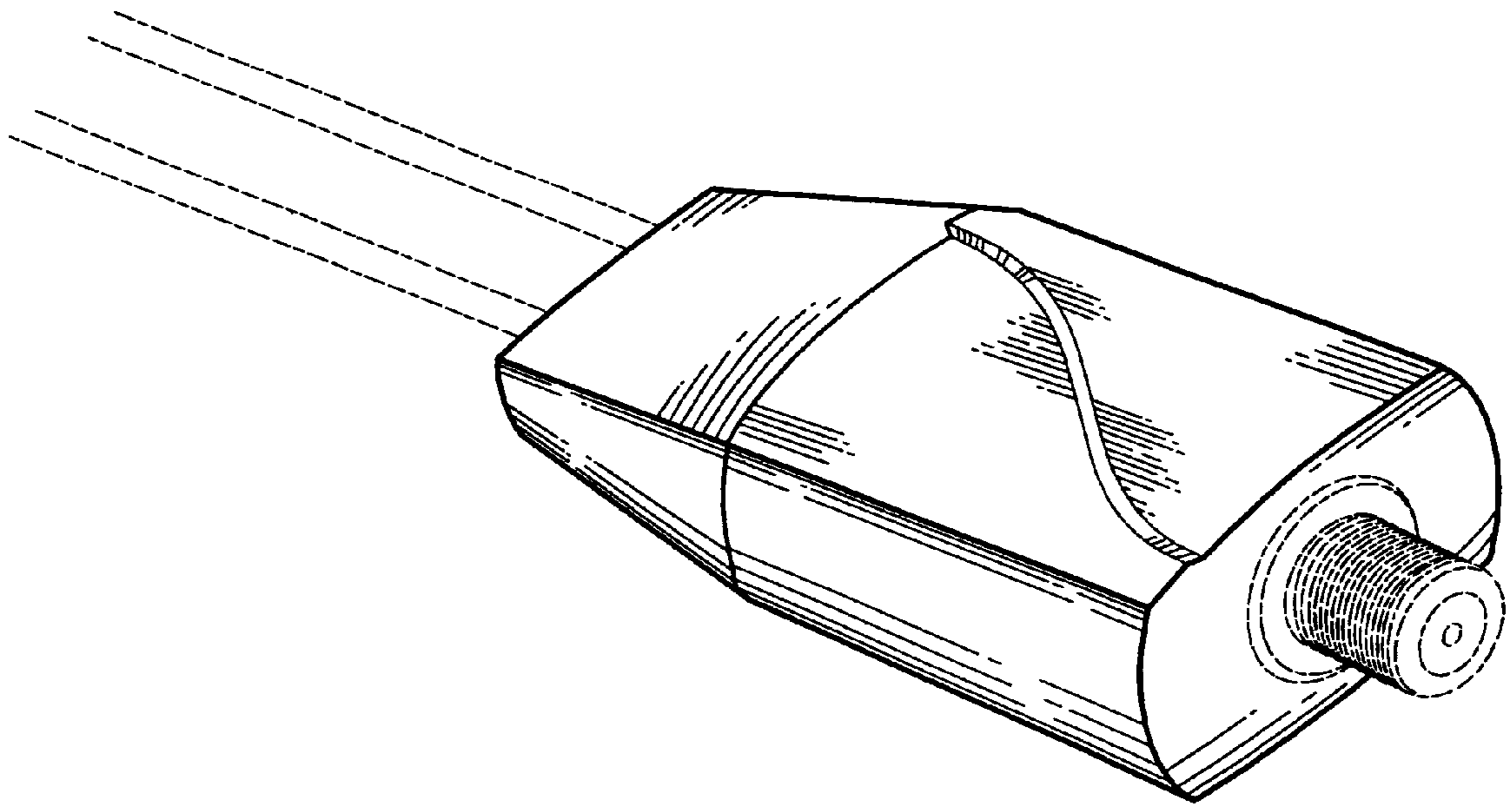

Fig. 6