



US00D446756B1

(12) **United States Design Patent**  
**York**

(10) **Patent No.:** **US D446,756 S**

(45) **Date of Patent:** **\*\* Aug. 21, 2001**

(54) **BRAKE ROTOR**

(75) Inventor: **Mervyn A. York**, Rancho Santa Fe, CA (US)

(73) Assignee: **Y-III Holdings Company, Inc.**, Carson, CA (US)

(\*\*) Term: **14 Years**

(21) Appl. No.: **29/130,477**

(22) Filed: **Oct. 2, 2000**

(51) **LOC (7) Cl.** ..... **12-16**

(52) **U.S. Cl.** ..... **D12/180**

(58) **Field of Search** ..... D12/180; 188/24.12, 188/24.13, 24.22, 24.11, 344, 209-211, 18 A, 218 XL, 71.5, 73.2; 192/107 R, 70.16

(56) **References Cited**

**U.S. PATENT DOCUMENTS**

|            |   |         |                |       |         |
|------------|---|---------|----------------|-------|---------|
| D. 376,783 | * | 12/1996 | Magalhaes      | ..... | D12/180 |
| D. 381,609 |   | 7/1997  | Ohata et al.   | .     |         |
| D. 381,610 |   | 7/1997  | Ohata et al.   | .     |         |
| D. 381,611 |   | 7/1997  | Ohata et al.   | .     |         |
| D. 413,093 |   | 8/1999  | Johnson et al. | .     |         |
| D. 416,526 |   | 11/1999 | Hsu            | .     |         |
| D. 419,934 |   | 2/2000  | DiBella        | .     |         |
| 2,451,709  |   | 10/1948 | Baselt         | .     |         |

|           |         |                  |   |
|-----------|---------|------------------|---|
| 2,473,040 | 6/1949  | Schlegel, Jr.    | . |
| 3,391,763 | 7/1968  | Severson         | . |
| 3,766,617 | 10/1973 | Forster et al.   | . |
| 3,809,192 | 5/1974  | Stehle           | . |
| 4,655,652 | 4/1987  | Schissler        | . |
| 4,821,848 | 4/1989  | Izumine          | . |
| 4,848,521 | 7/1989  | Izumine          | . |
| 5,417,313 | 5/1995  | Matsuzaki et al. | . |
| 5,501,306 | 3/1996  | Martino          | . |
| 5,878,479 | 3/1999  | Dickerson et al. | . |
| 5,915,747 | 6/1999  | Dickerson et al. | . |

\* cited by examiner

*Primary Examiner*—Melody N. Brown

(74) *Attorney, Agent, or Firm*—Karin E. Peterka

(57) **CLAIM**

The ornamental design of a brake rotor, as shown and described.

**DESCRIPTION**

FIG. 1 is a perspective view of the brake rotor of the present invention, the front and back views being identical; FIG. 2 is a side view of the brake rotor in FIG. 1, the right and left side views being identical; FIG. 3 is a top view of the brake rotor in FIG. 1; and, FIG. 4 is a bottom view of the brake rotor in FIG. 1.

**1 Claim, 2 Drawing Sheets**

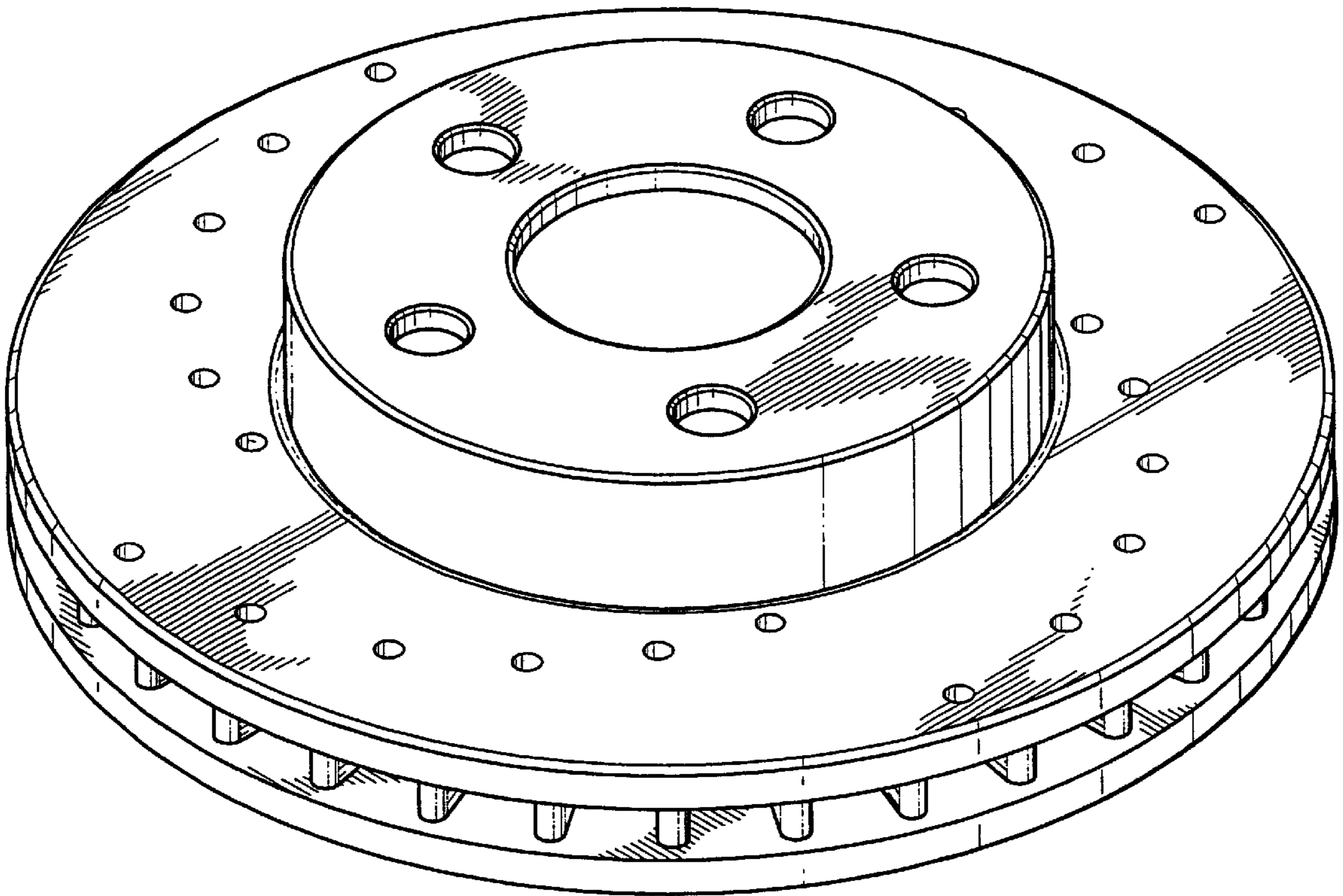

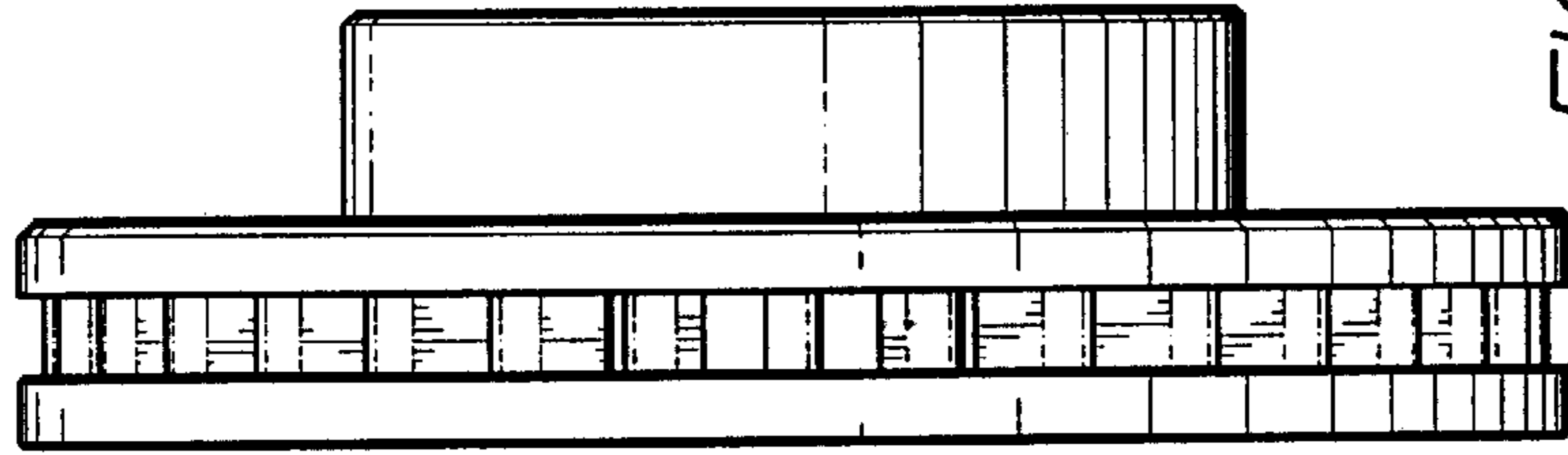

FIG. 2

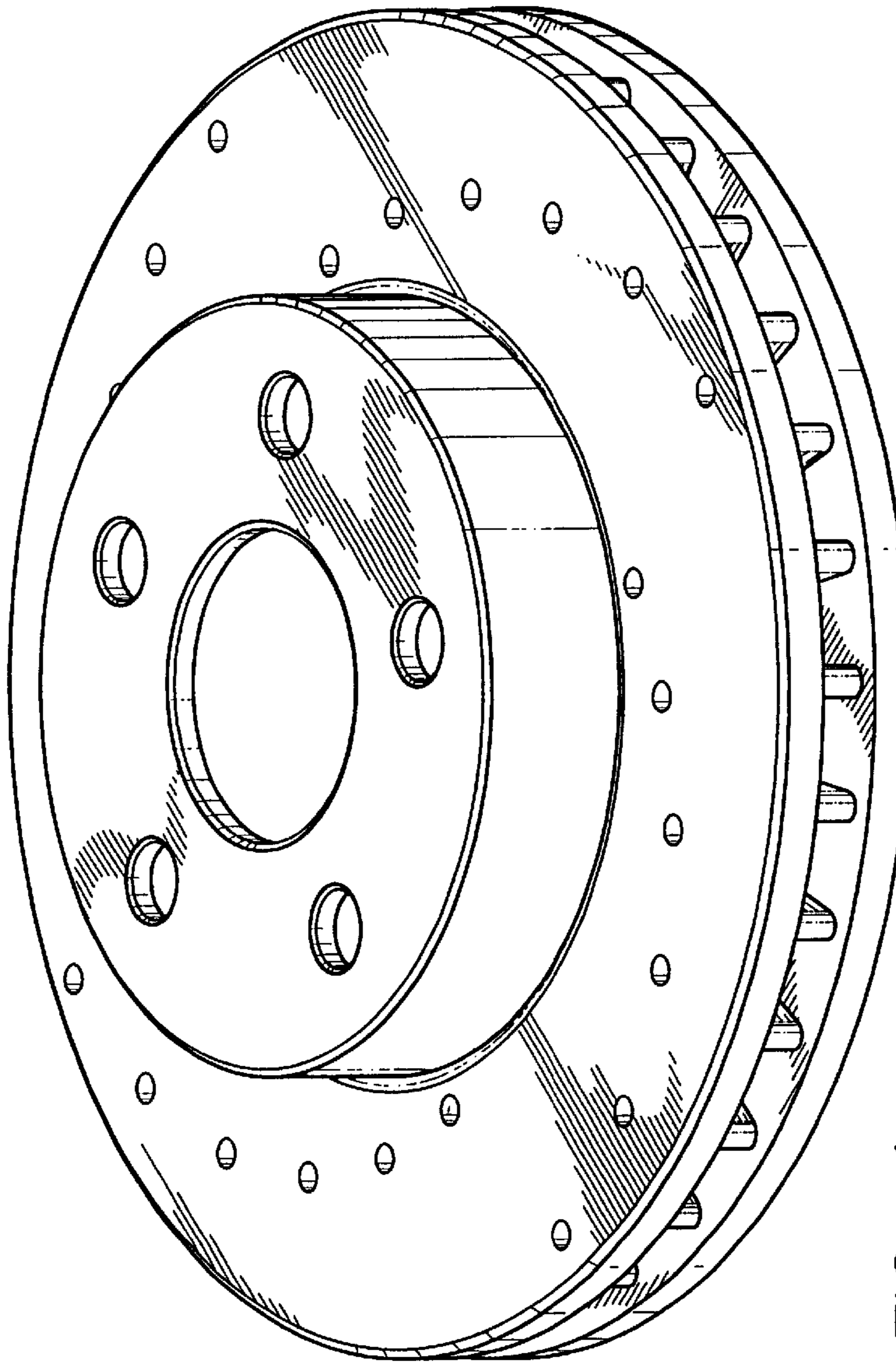

FIG. 1

FIG. 3

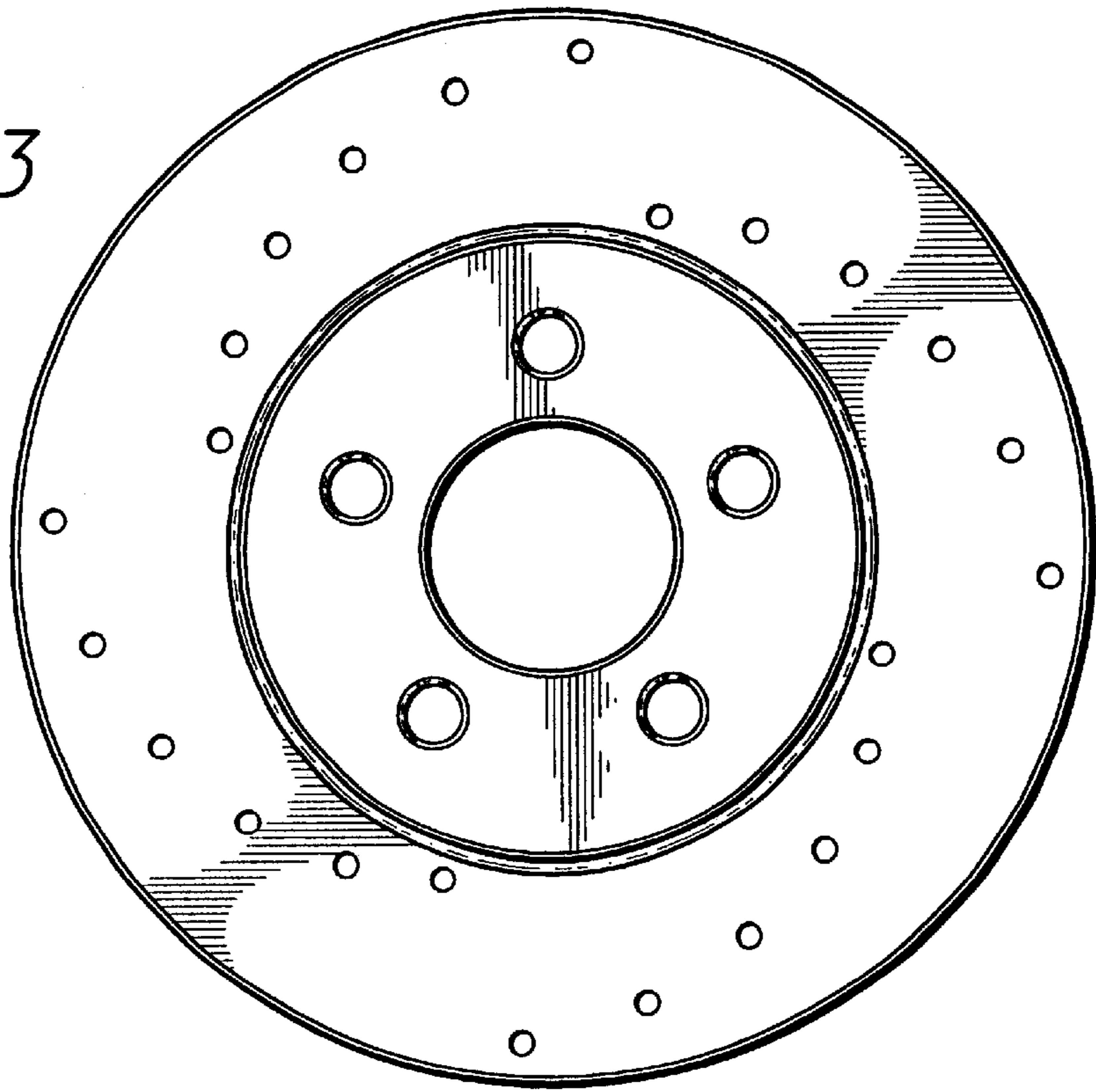

FIG. 4

