



US00D446753B1

(12) **United States Design Patent**
Golden et al.

(10) **Patent No.:** **US D446,753 S**

(45) **Date of Patent:** **** Aug. 21, 2001**

(54) **MOTORCYCLE AIR CLEANER COVER**

(75) Inventors: **Earl F. Golden**, Milwaukee; **William G. Davidson**, Delafield, both of WI (US)

(73) Assignee: **Harley-Davidson Motor Company**, Milwaukee, WI (US)

(**) Term: **14 Years**

(21) Appl. No.: **29/114,408**

(22) Filed: **Nov. 23, 1999**

Related U.S. Application Data

(63) Continuation of application No. 29/076,809, filed on Sep. 18, 1997, now Pat. No. Des. 416,832.

(51) **LOC (7) Cl.** **12-11**

(52) **U.S. Cl.** **D12/126**

(58) **Field of Search** D12/110, 114,
D12/126; 180/219; 280/288.4; 123/198 E,
195 C

(56) **References Cited**

U.S. PATENT DOCUMENTS

- D. 294,923 * 3/1988 Nagy D12/126
- D. 354,460 * 1/1995 Davidson et al. D12/126
- D. 363,259 * 10/1995 Davidson et al. D12/126
- D. 392,601 3/1998 Ban et al. .
- D. 394,027 5/1998 Ban et al. .

OTHER PUBLICATIONS

1994 Harley-Davidson Genuine Parts & Accessories, pp. 12, 52, 70 and 103.

1997 J&P Cycles Catalog, pp. 5-12, 5-13 & 5-14.

Custom Chrome, air cleaner covers shown on pp. 9.14 and 9.16, 1999.*

Drag Specialties Fatbook, air cleaner covers shown on pp. 225-227, 1999.*

Harley-Davidson® Genuine Motor Accessories™ & Genuine Motor Parts™, air cleaner cover on p. 141, 1999.*

* cited by examiner

Primary Examiner—Alan P. Douglas

Assistant Examiner—Linda Brooks

(74) *Attorney, Agent, or Firm*—Michael Best & Friedrich LLP

(57) **CLAIM**

We claim the ornamental design for a motorcycle air cleaner cover, as shown and described.

DESCRIPTION

FIG. 1 is a top perspective view of a motorcycle air cleaner cover showing our new design;

FIG. 2 is a top plan view thereof;

FIG. 3 is a right side elevational view thereof;

FIG. 4 is a left side elevational view thereof;

FIG. 5 is a front elevational view thereof, the rear elevational view being a mirror image thereof;

FIG. 6 is a top perspective view of a second embodiment of the design shown in FIGS. 1-5;

FIG. 7 is a top plan view of the second embodiment;

FIG. 8 is a right side elevational view of the second embodiment;

FIG. 9 is a left side elevational view of the second embodiment; and,

FIG. 10 is a front elevational view of the second embodiment of the second embodiment, the rear elevational view being a mirror image thereof.

The broken lines which define the bounds of the claimed design form no part thereof. The broken line environmental showing is for illustrative purposes only and forms no part of the claimed design.

1 Claim, 4 Drawing Sheets

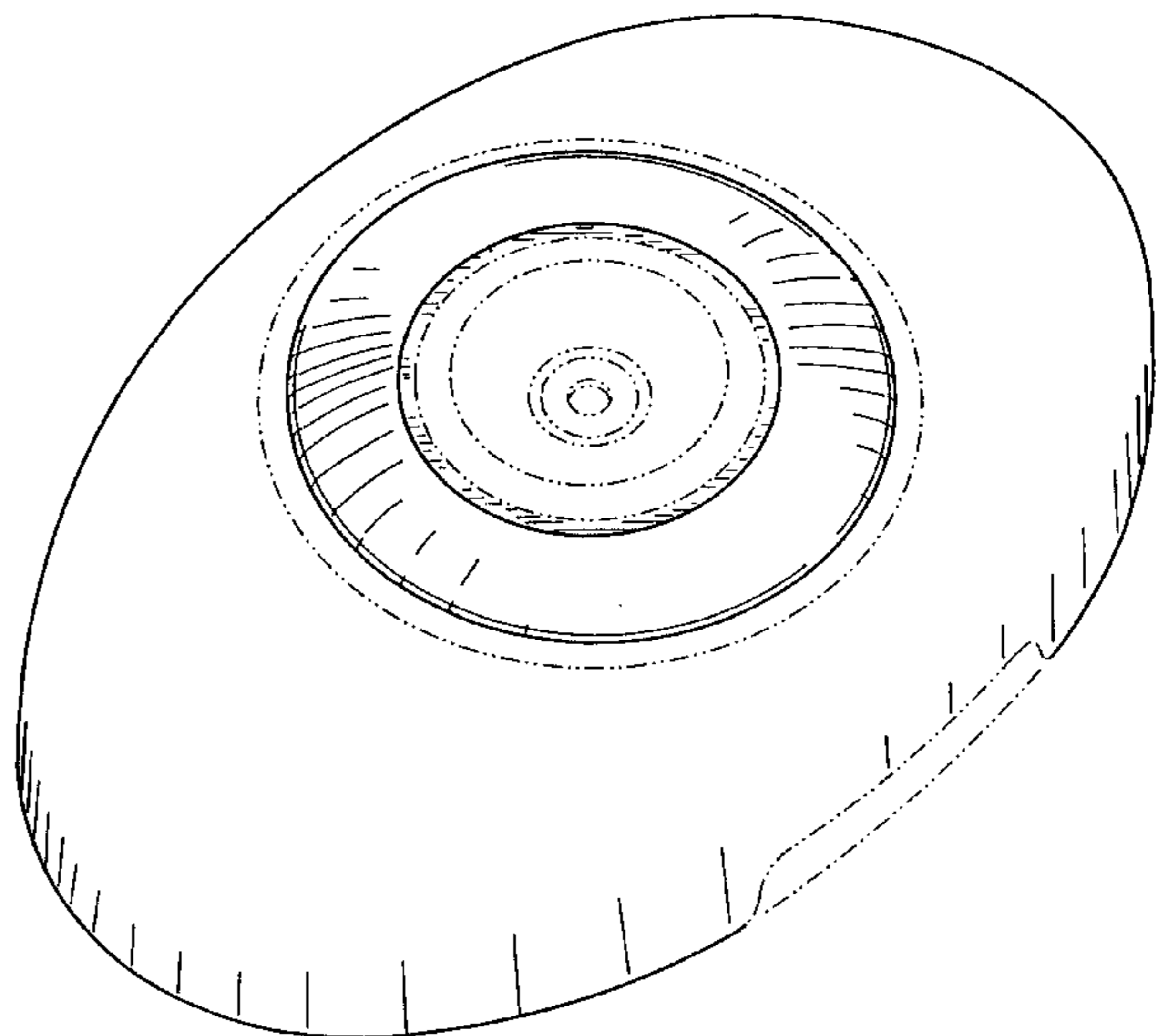
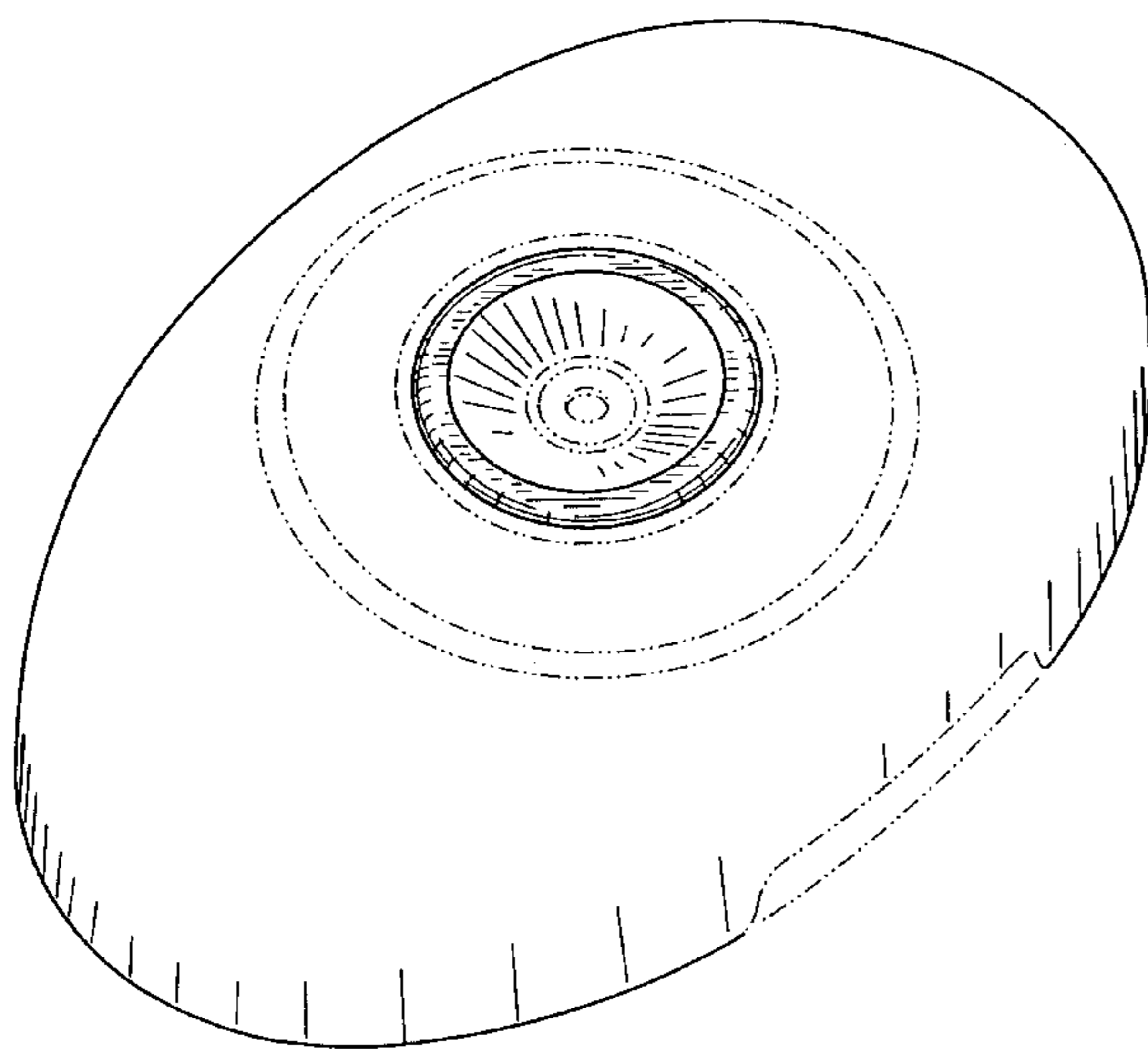

FIG. 1

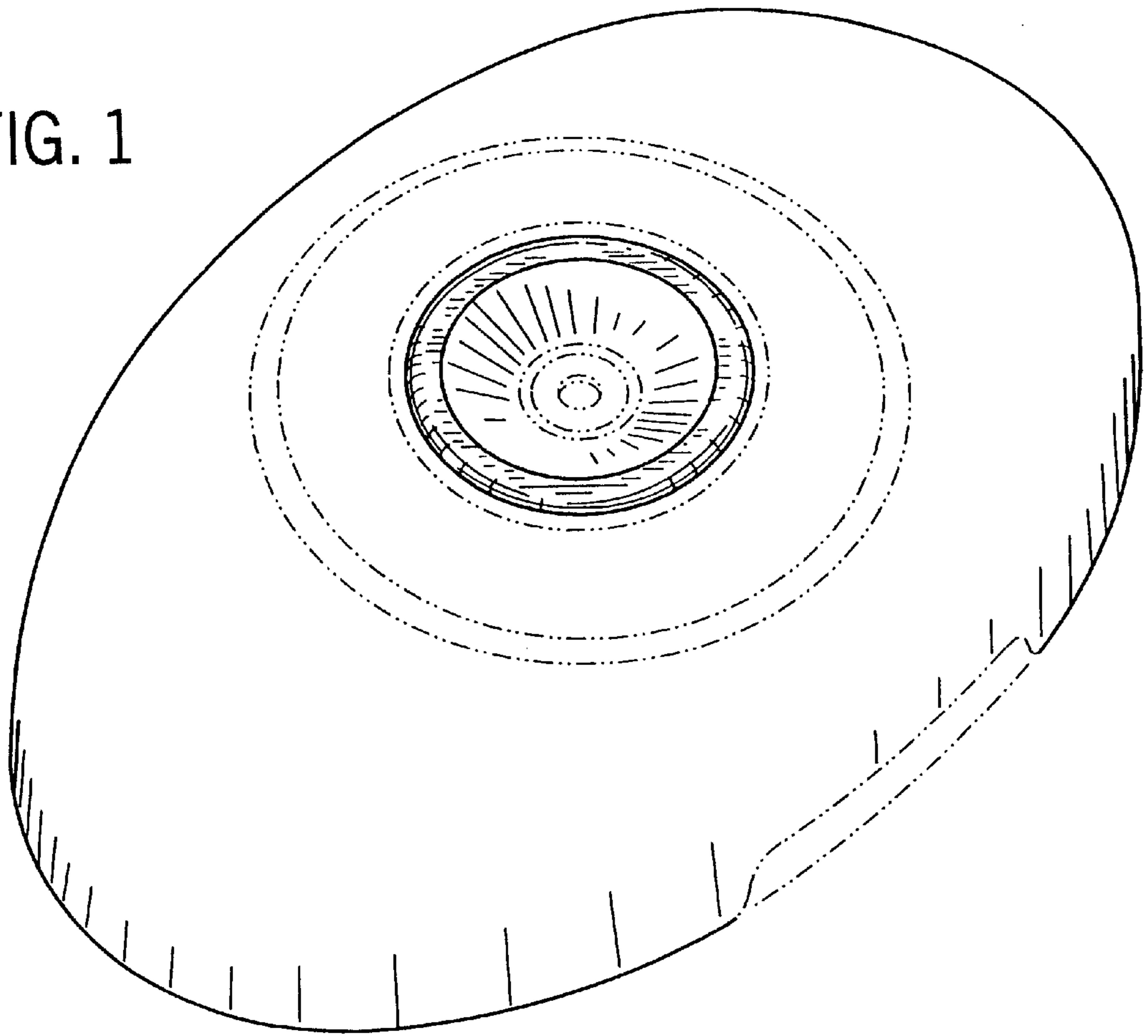

FIG. 5

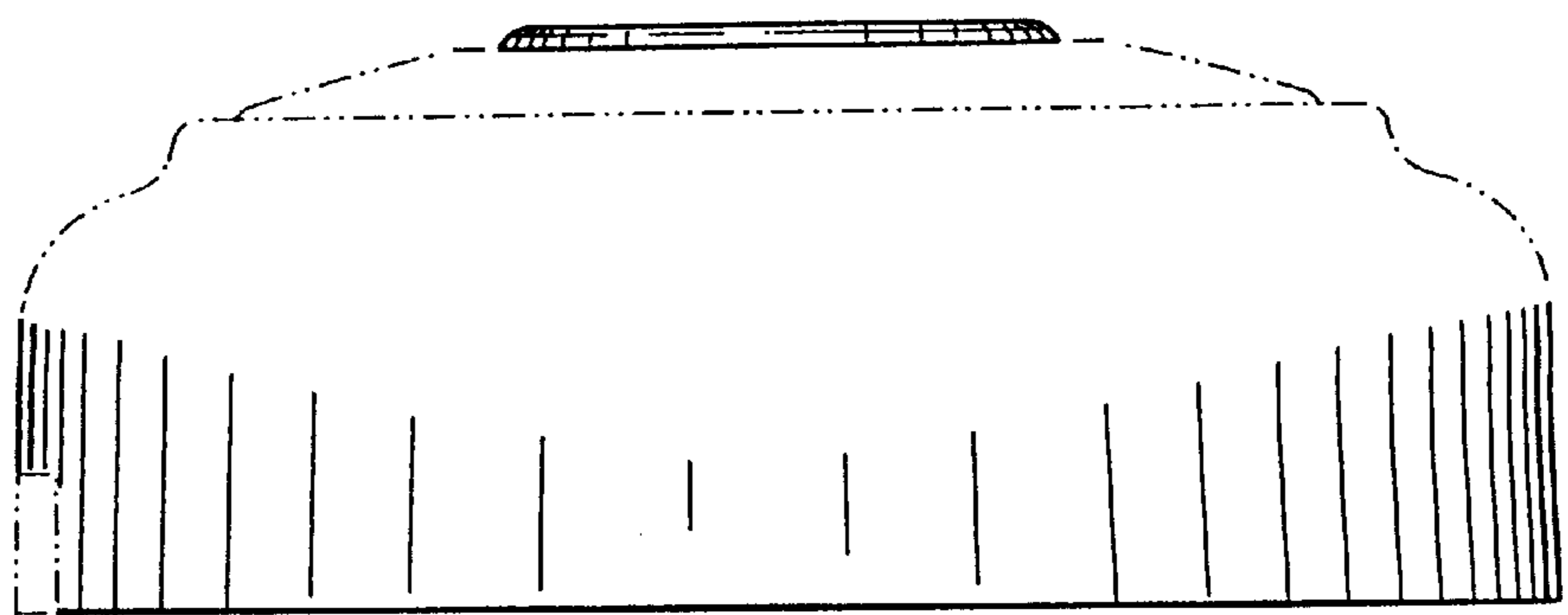

FIG. 2

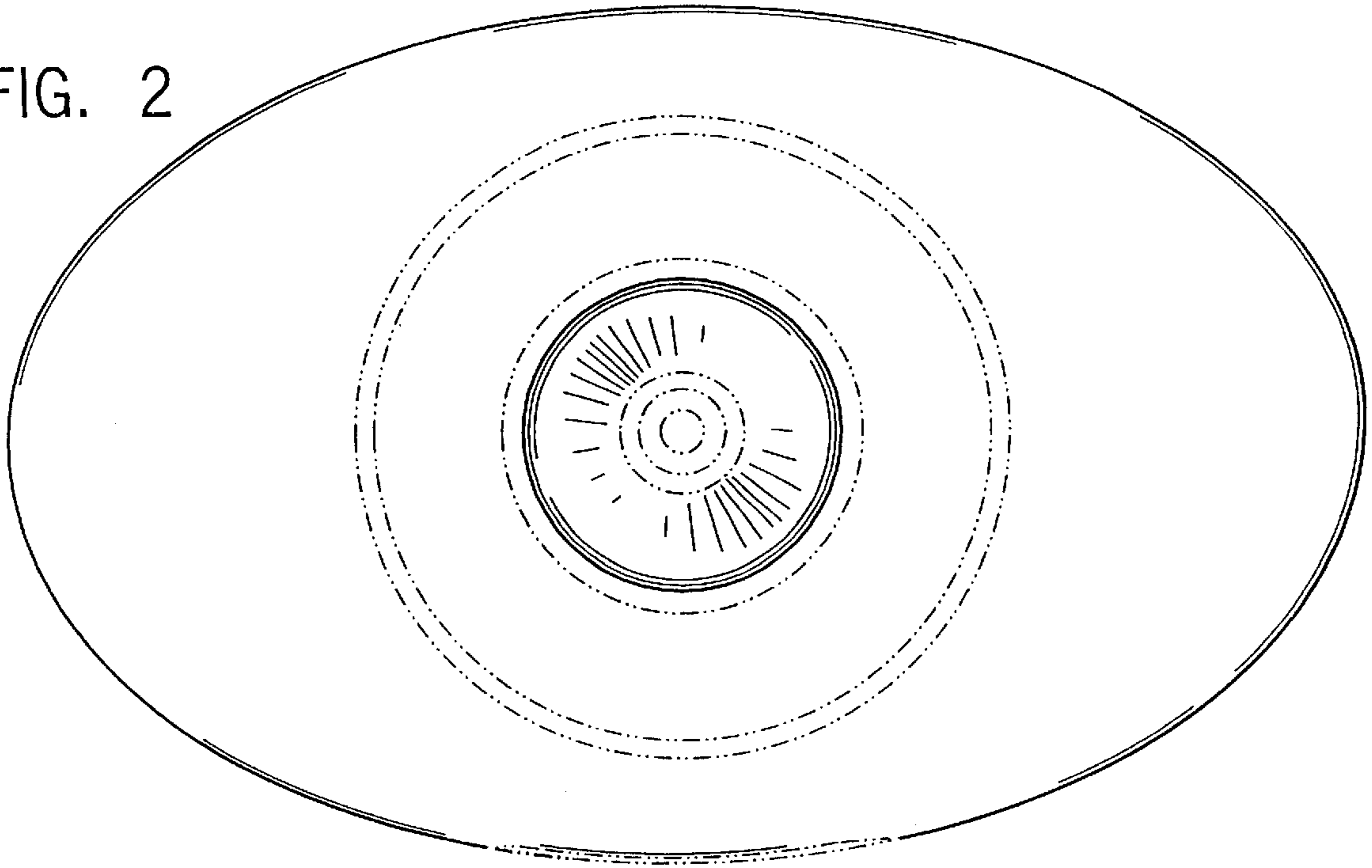

FIG. 3

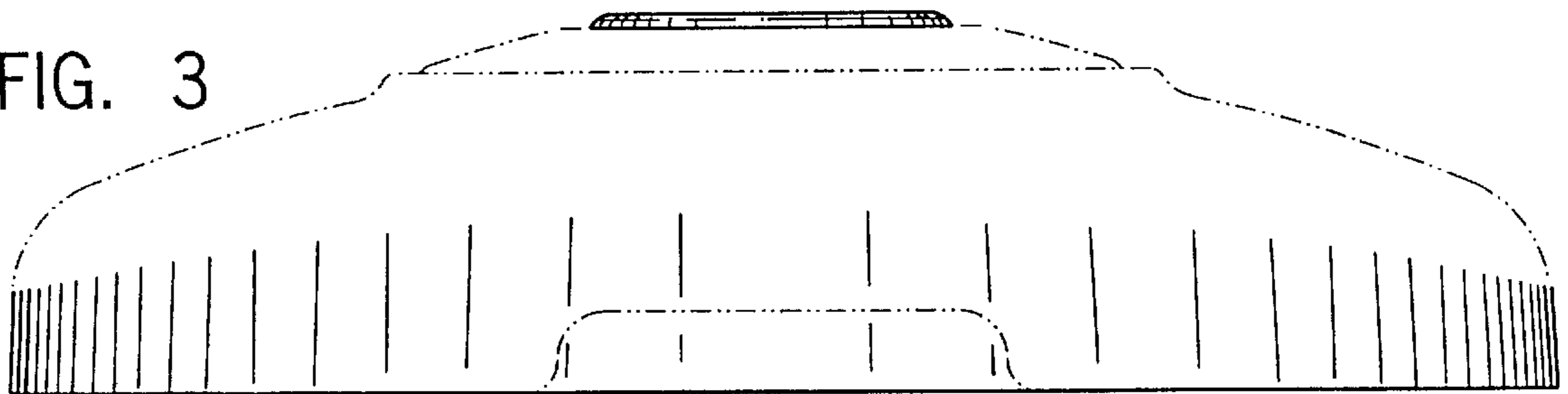

FIG. 4

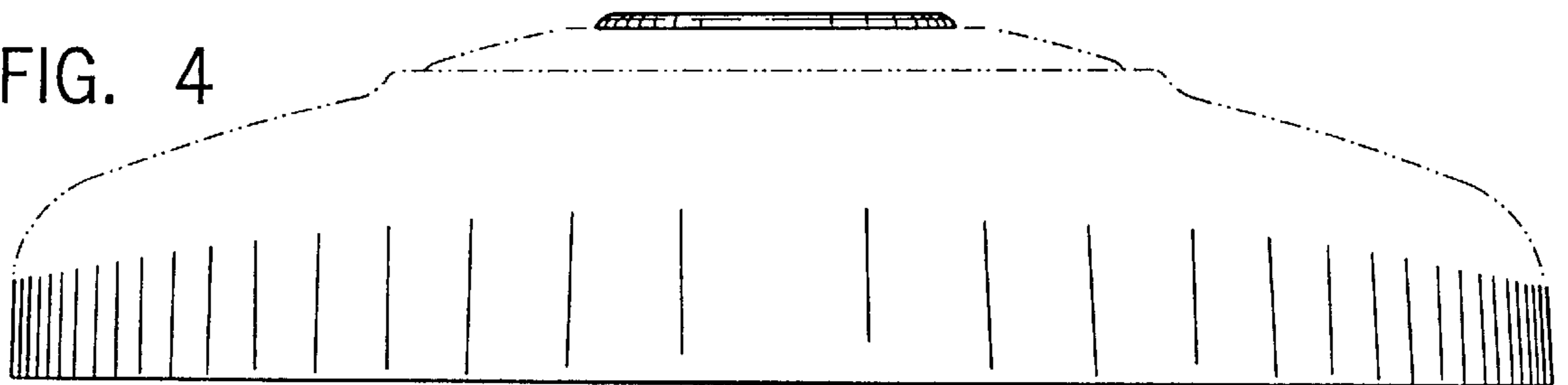

FIG. 6

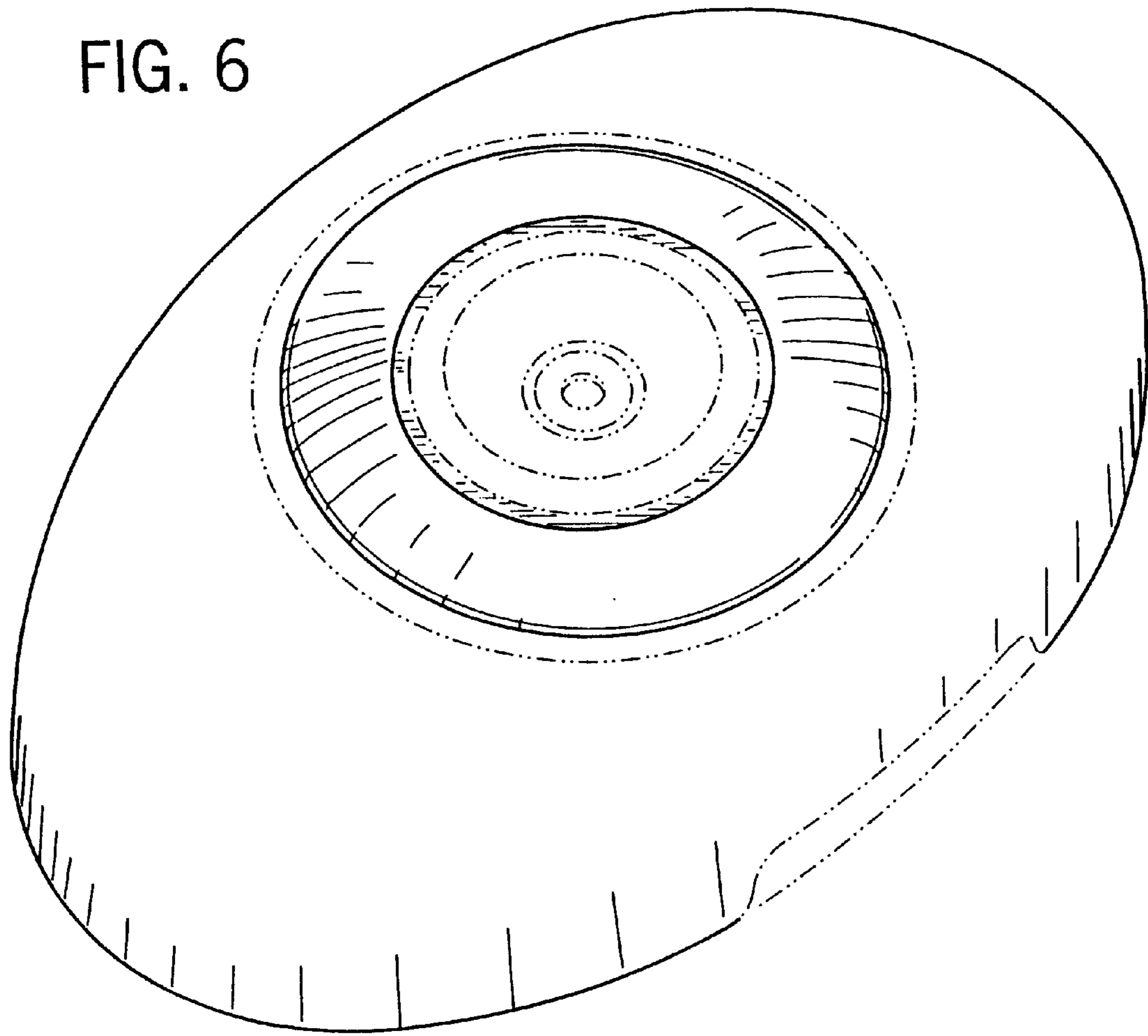

FIG. 10

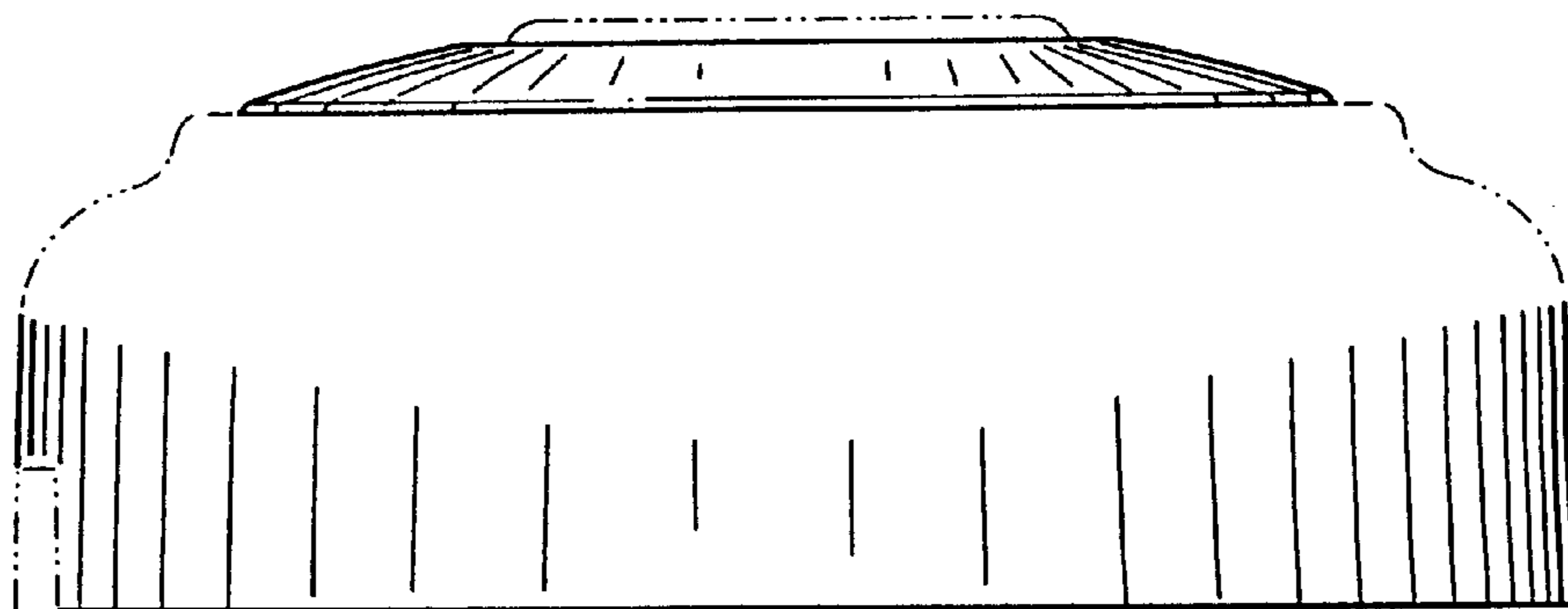

FIG. 7

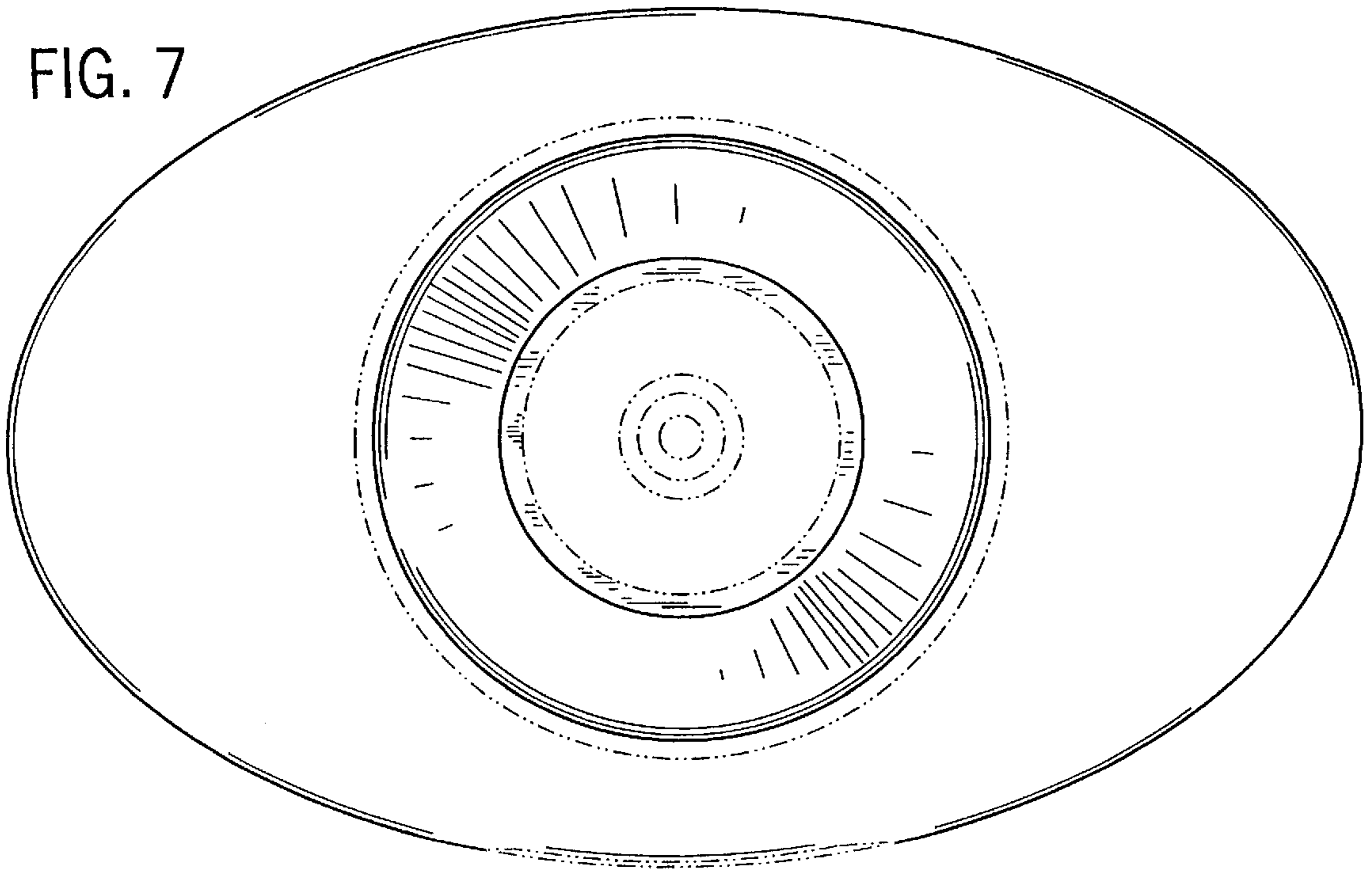

FIG. 8

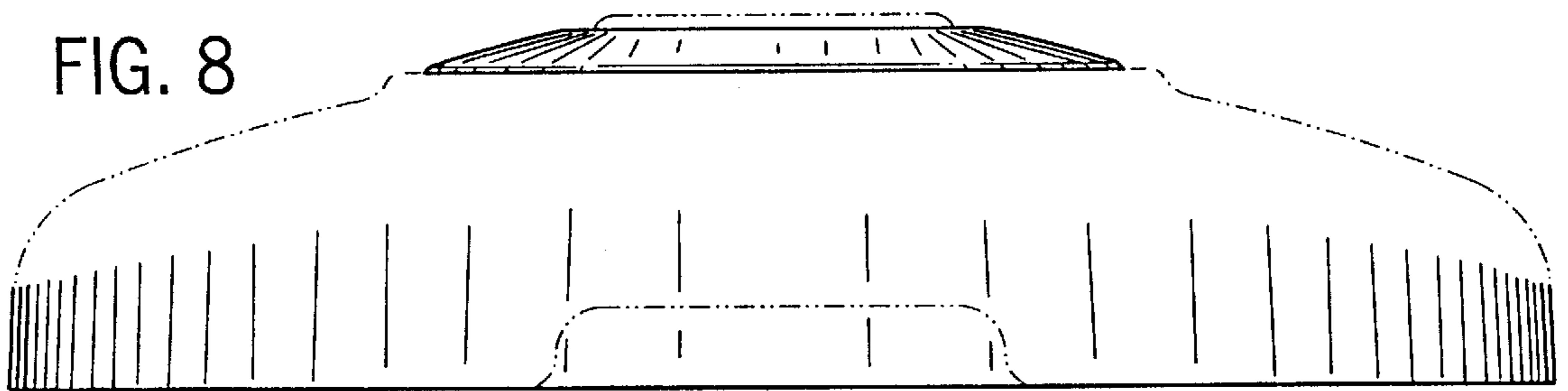

FIG. 9

