



US00D446491B1

(12) **United States Design Patent**
Maeda et al.

(10) **Patent No.:** **US D446,491 S**

(45) **Date of Patent:** **** Aug. 14, 2001**

(54) **FRONT PORTION OF MOTOR VEHICLE**

(75) Inventors: **Ikuo Maeda; Yasushi Nakamuta; Takeshi Fujii; Fumihiko Kubo**, all of Hiroshima-ken (JP); **Wu-Huang Chin**, Irvine, CA (US)

(73) Assignee: **Mazda Motor Corporation**, Hiroshima-Ken (JP)

(**) Term: **14 Years**

(21) Appl. No.: **29/128,007**

(22) Filed: **Aug. 17, 2000**

(51) **LOC (7) Cl.** **12-16**

(52) **U.S. Cl.** **D12/196**

(58) **Field of Search** D12/196, 90-92;
296/185

(56) **References Cited**

U.S. PATENT DOCUMENTS

- D. 353,792 12/1994 Daikoku D12/92
- D. 425,844 * 5/2000 Toyoda D12/196
- D. 432,065 * 10/2000 Kitamura D12/196
- D. 435,497 * 12/2000 Nishihata et al. D12/169

* cited by examiner

Primary Examiner—Melody N. Brown
(74) *Attorney, Agent, or Firm*—Nixon Peabody LLP;
Donald R. Studebaker

(57) **CLAIM**

The ornamental design for a front portion of motor vehicle, as shown and described.

DESCRIPTION

FIG. 1 is a perspective view of front portion of motor vehicle showing a first embodiment of our new design;
 FIG. 2 is a front view thereof;
 FIG. 3 is a rear view thereof;
 FIG. 4 is a right side view thereof;
 FIG. 5 is a left side view thereof;
 FIG. 6 is a top view thereof;
 FIG. 7 is a perspective view of front portion of motor vehicle showing a second embodiment of our new design;
 FIG. 8 is a front view thereof;
 FIG. 9 is a rear view thereof;
 FIG. 10 is a left side view thereof;
 FIG. 11 is a right side view thereof; and,
 FIG. 12 is a top view thereof.

The motor vehicle shown by broken lines is for illustrative purposes only and forms no part of the claimed design.

1 Claim, 10 Drawing Sheets

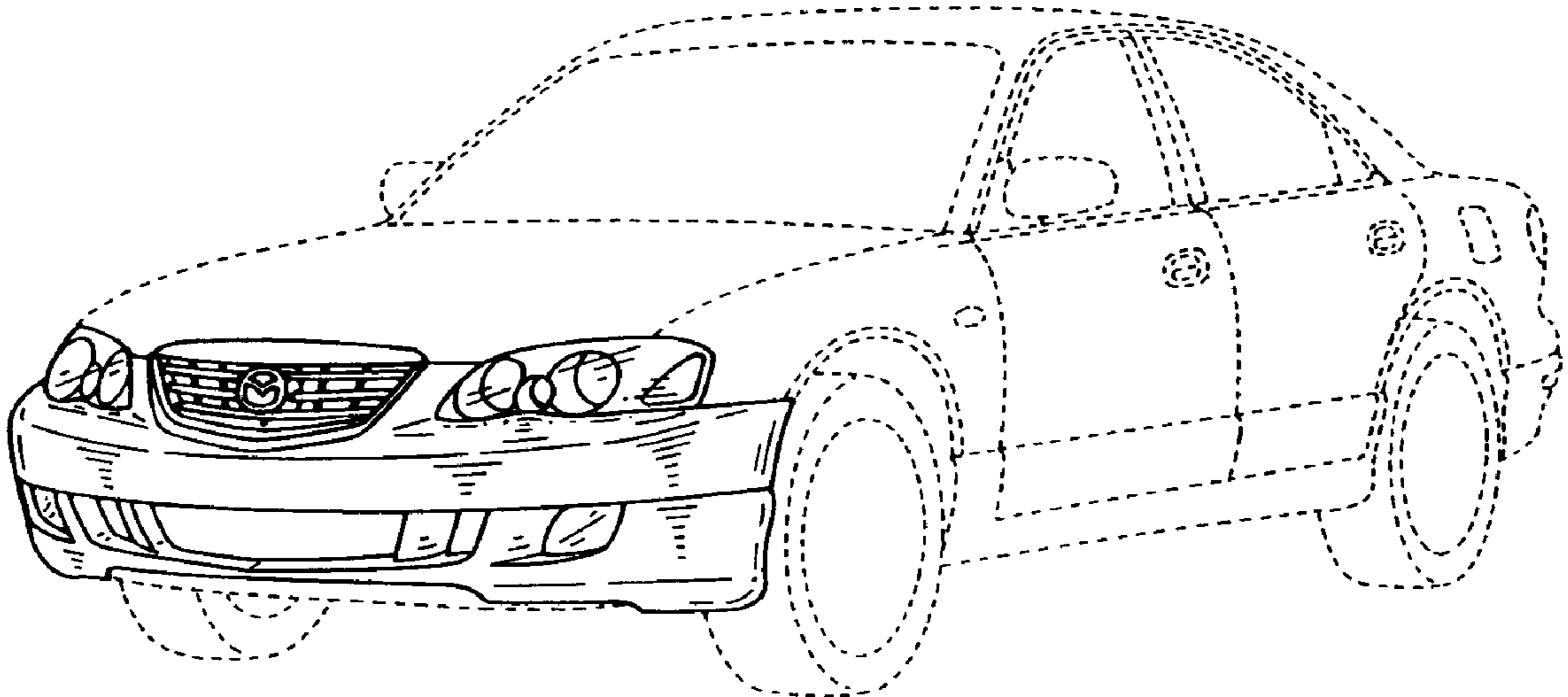

FIG. 1

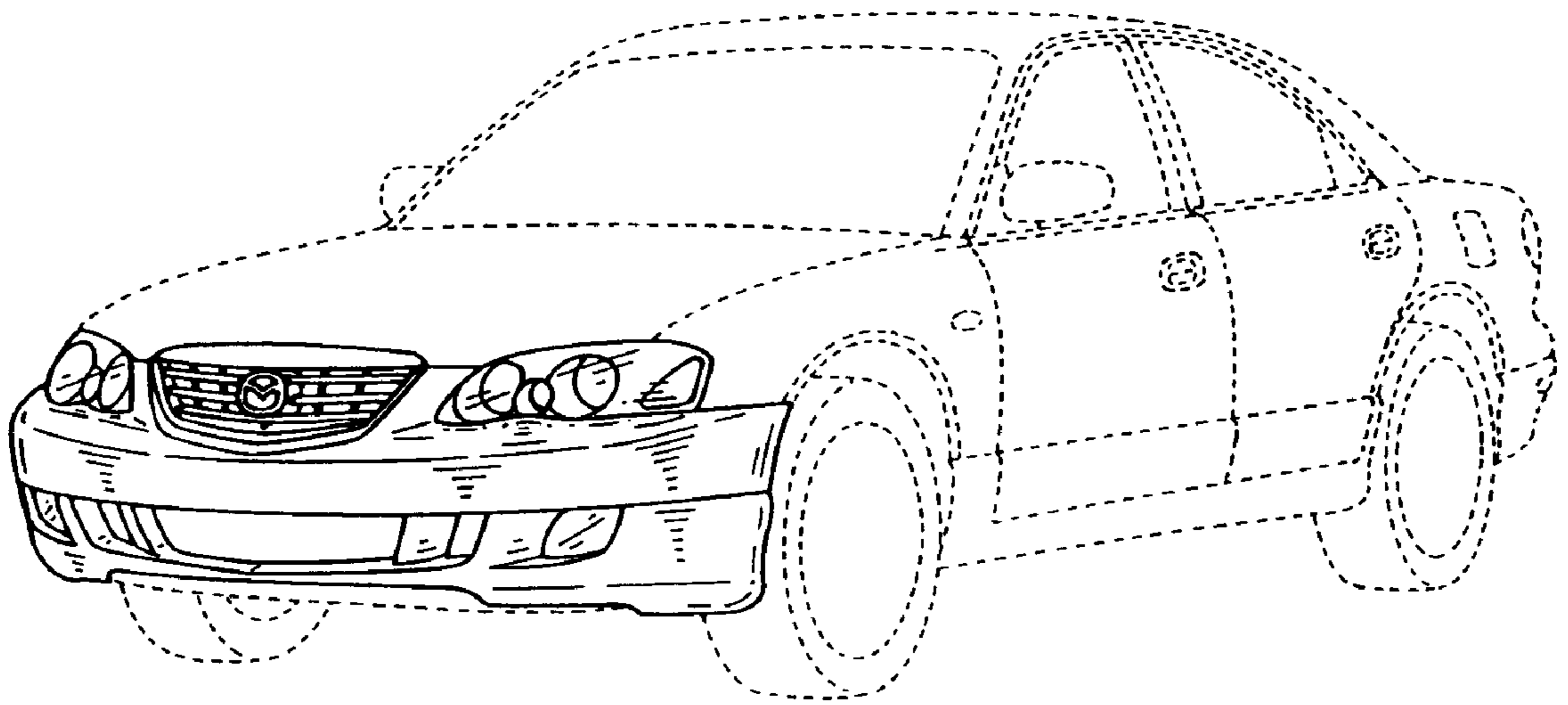

FIG. 2

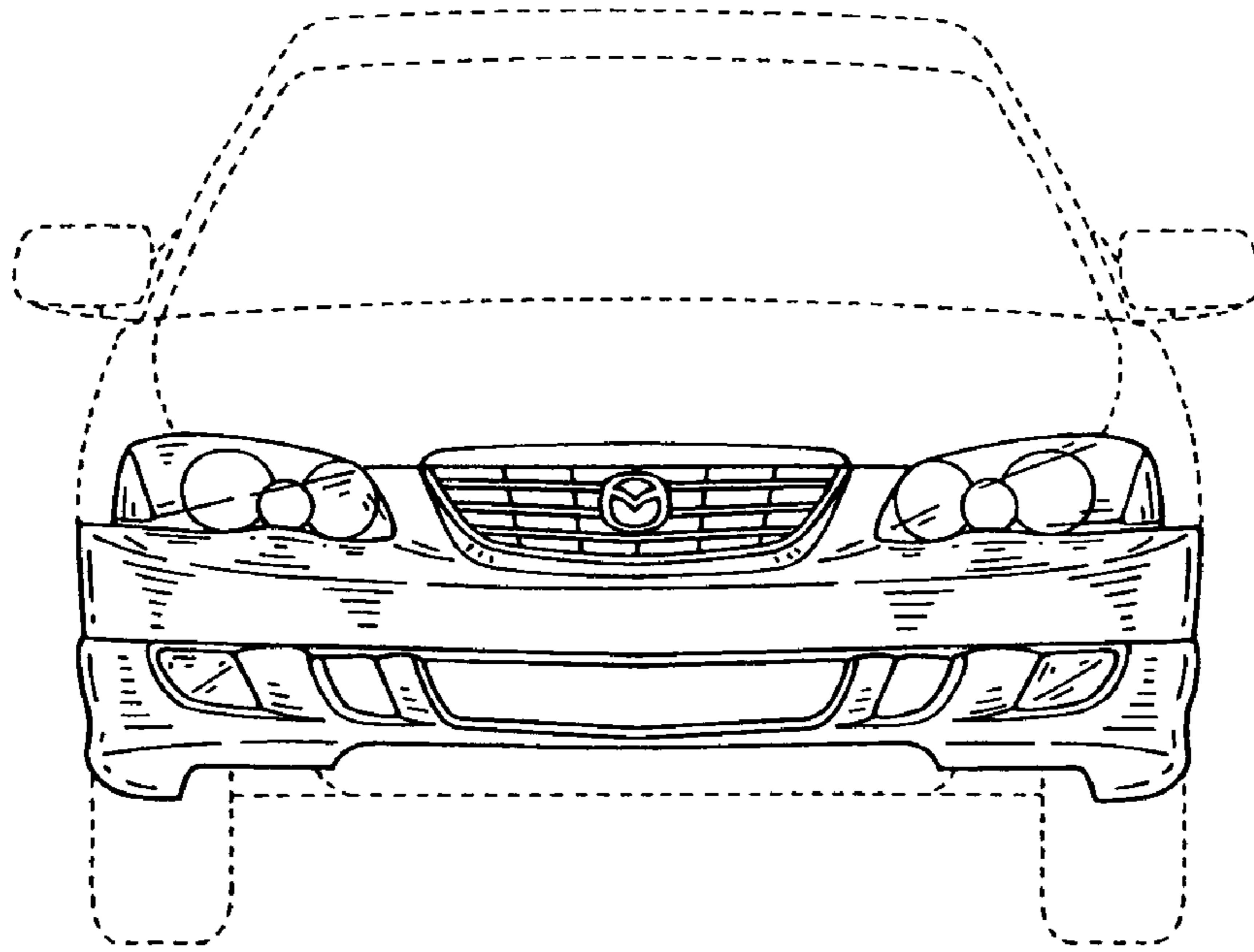
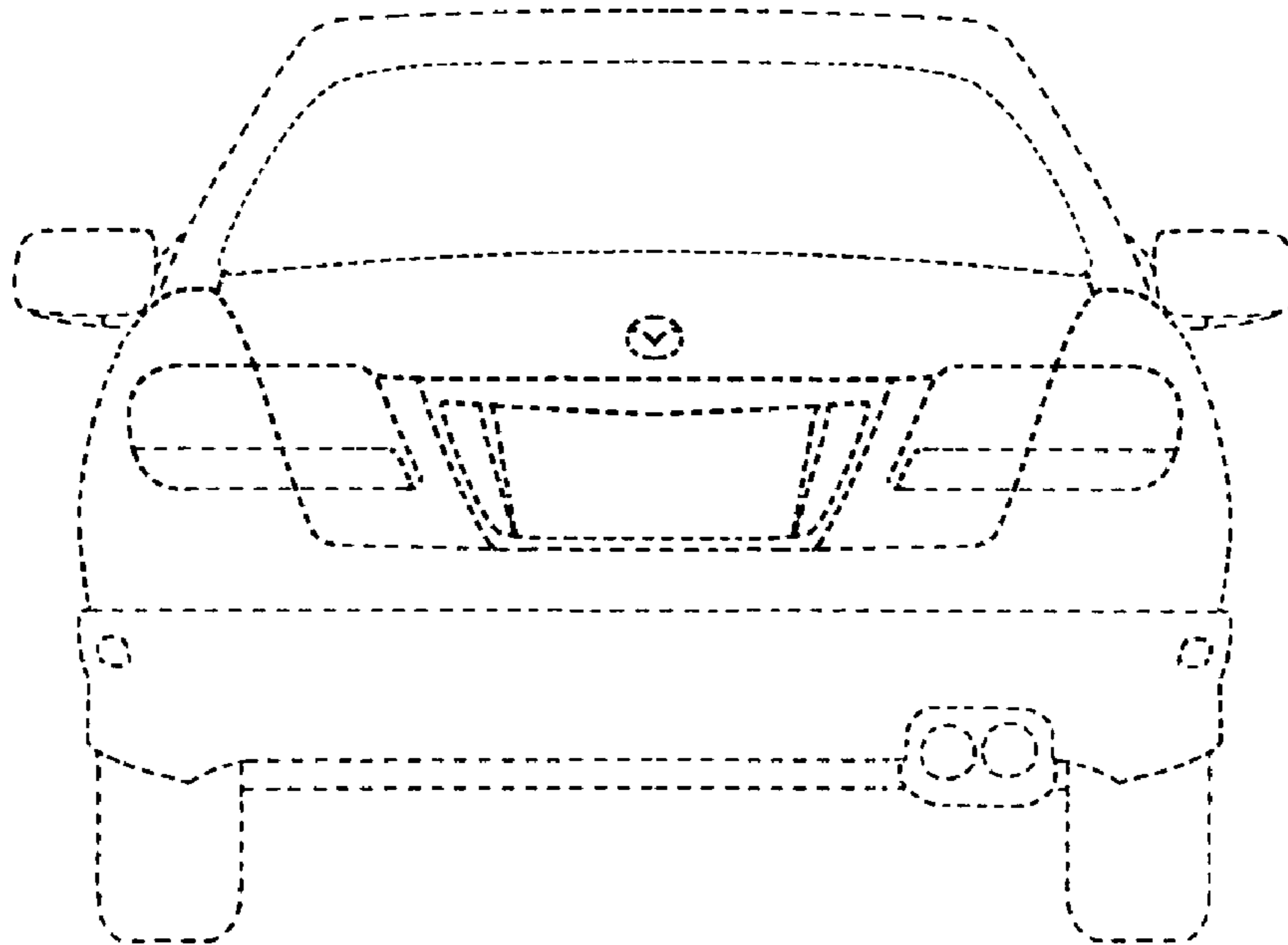

FIG. 3



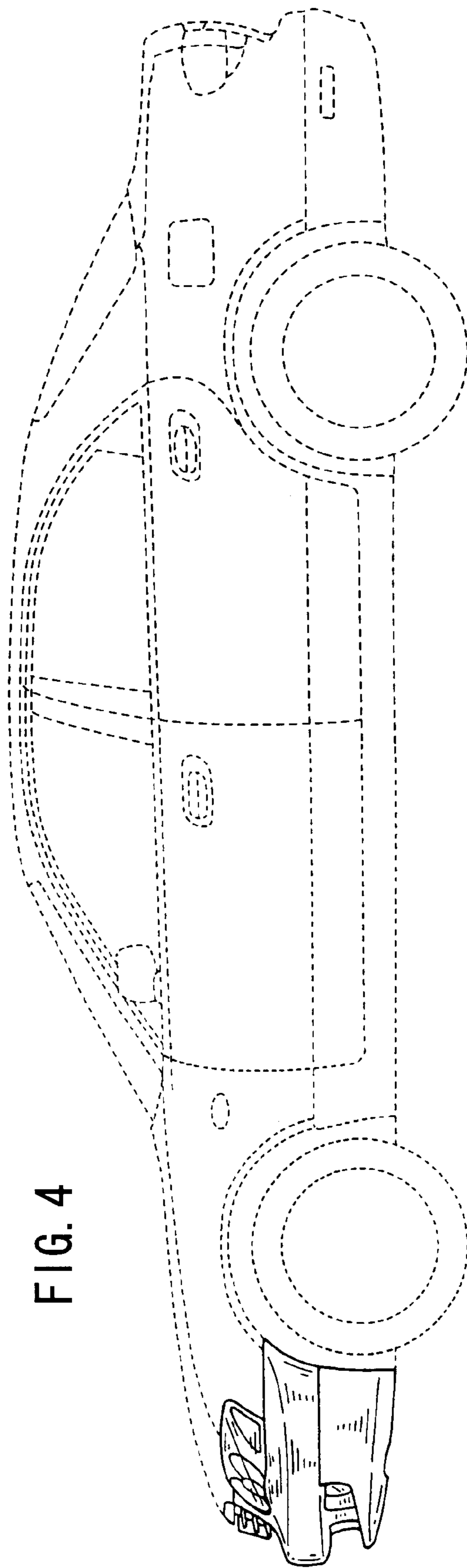

FIG. 4

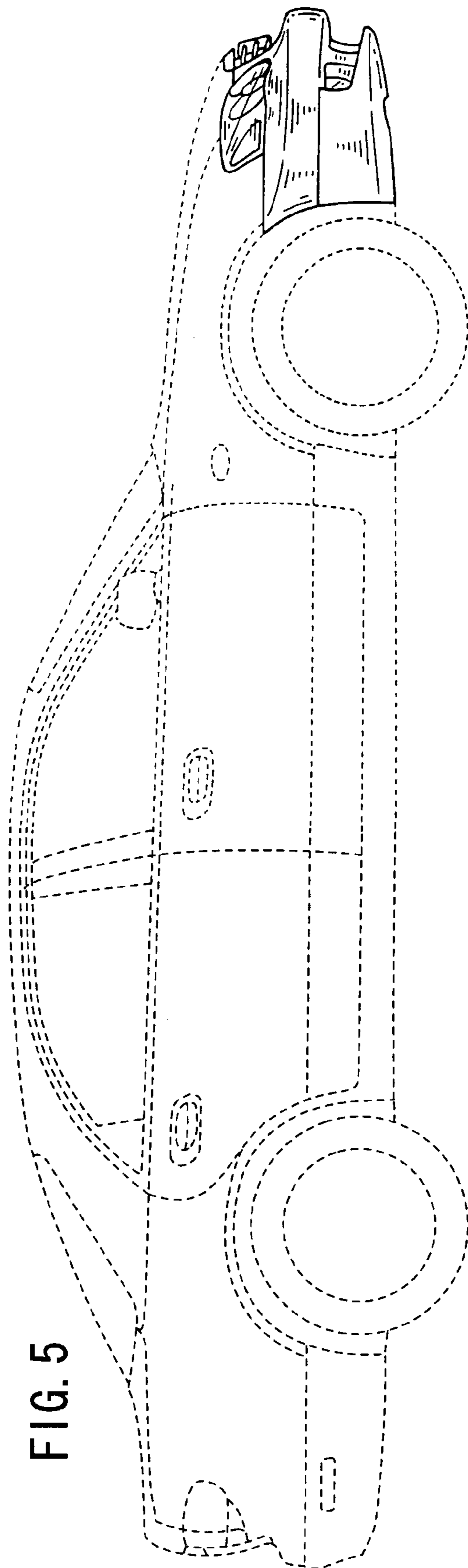

FIG. 5

FIG. 6

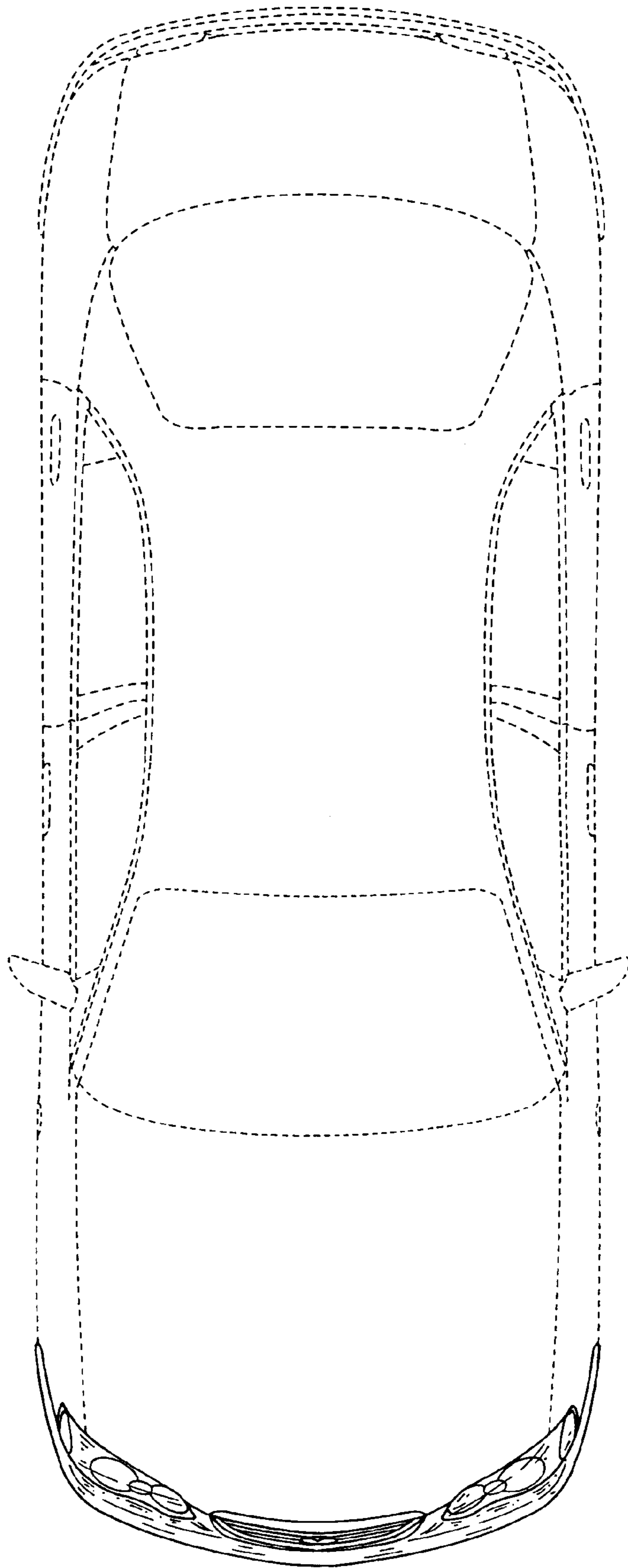

FIG. 7

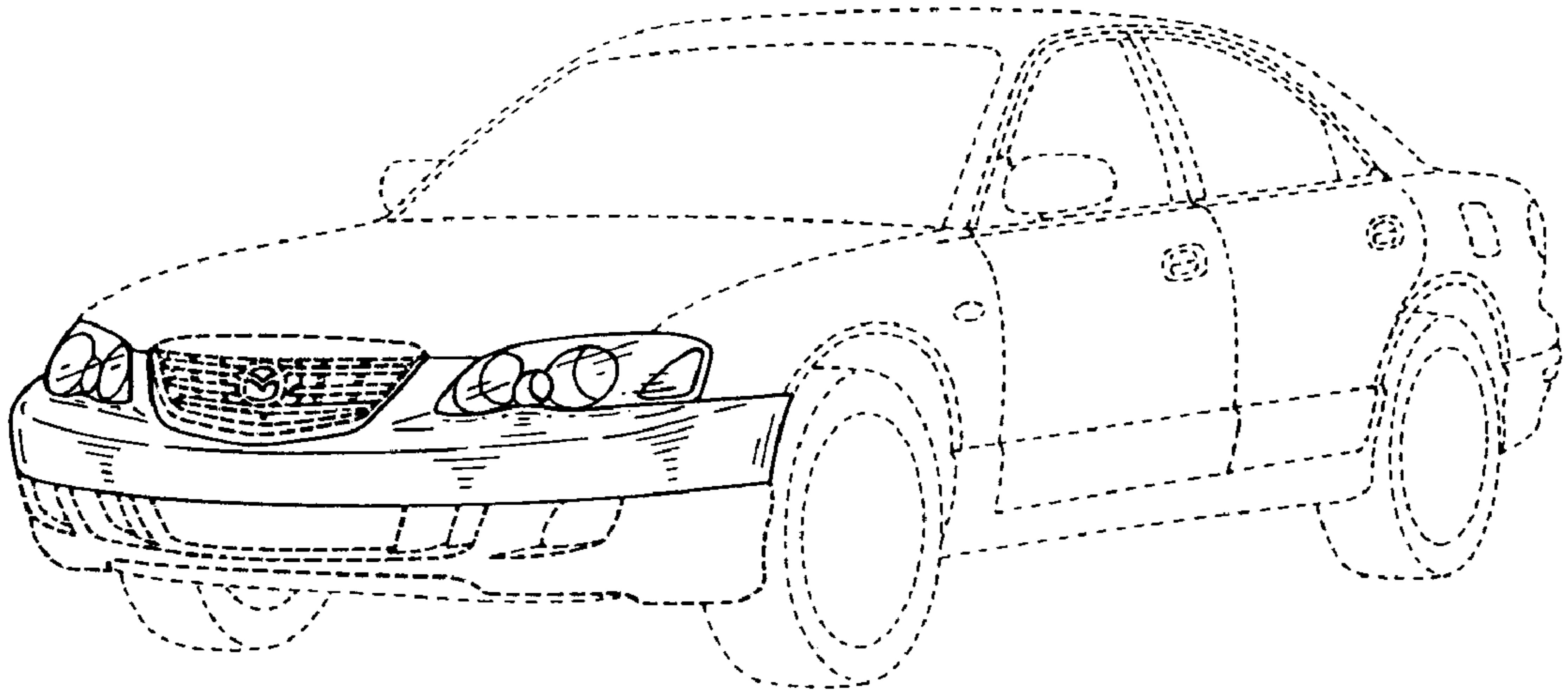

FIG. 8

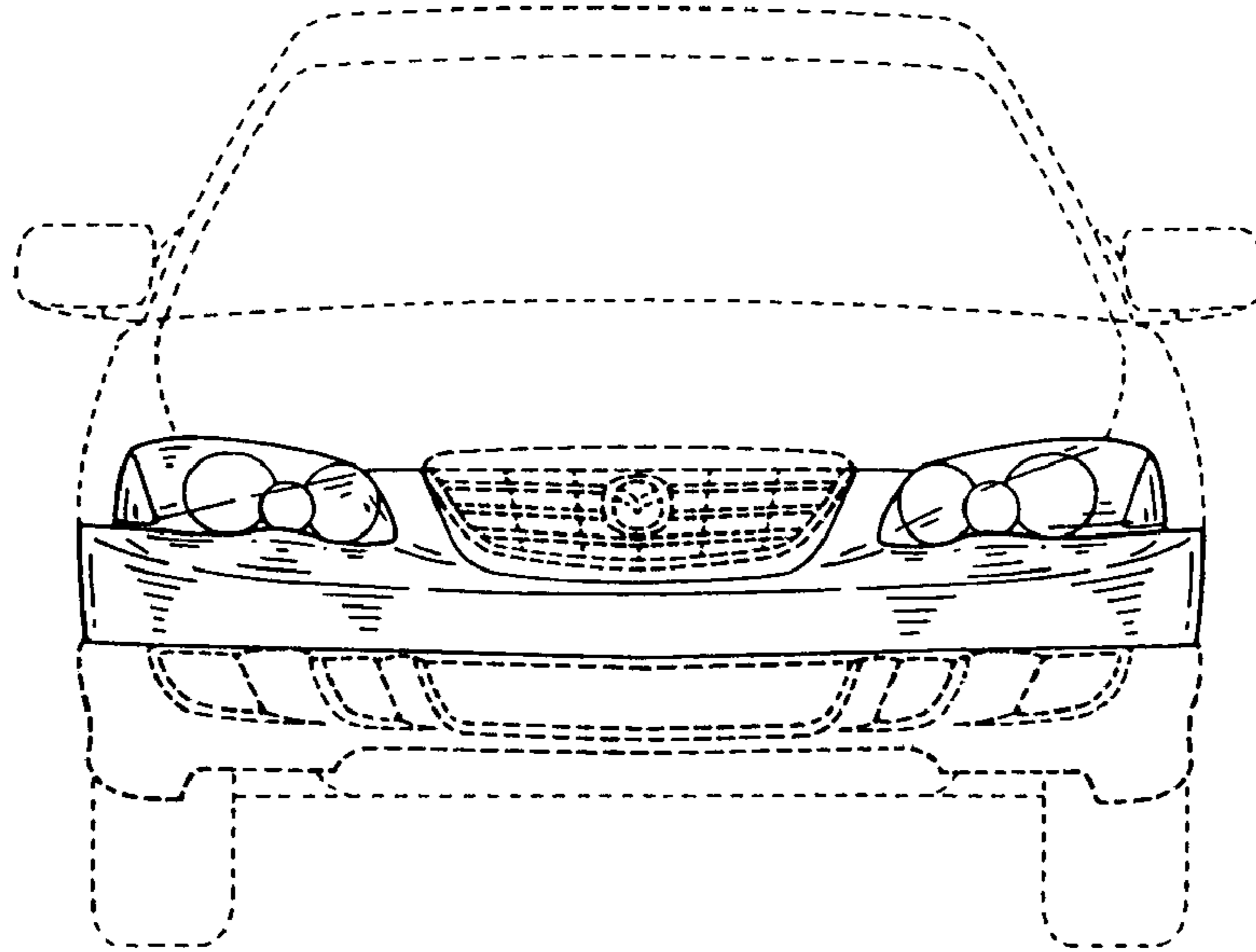
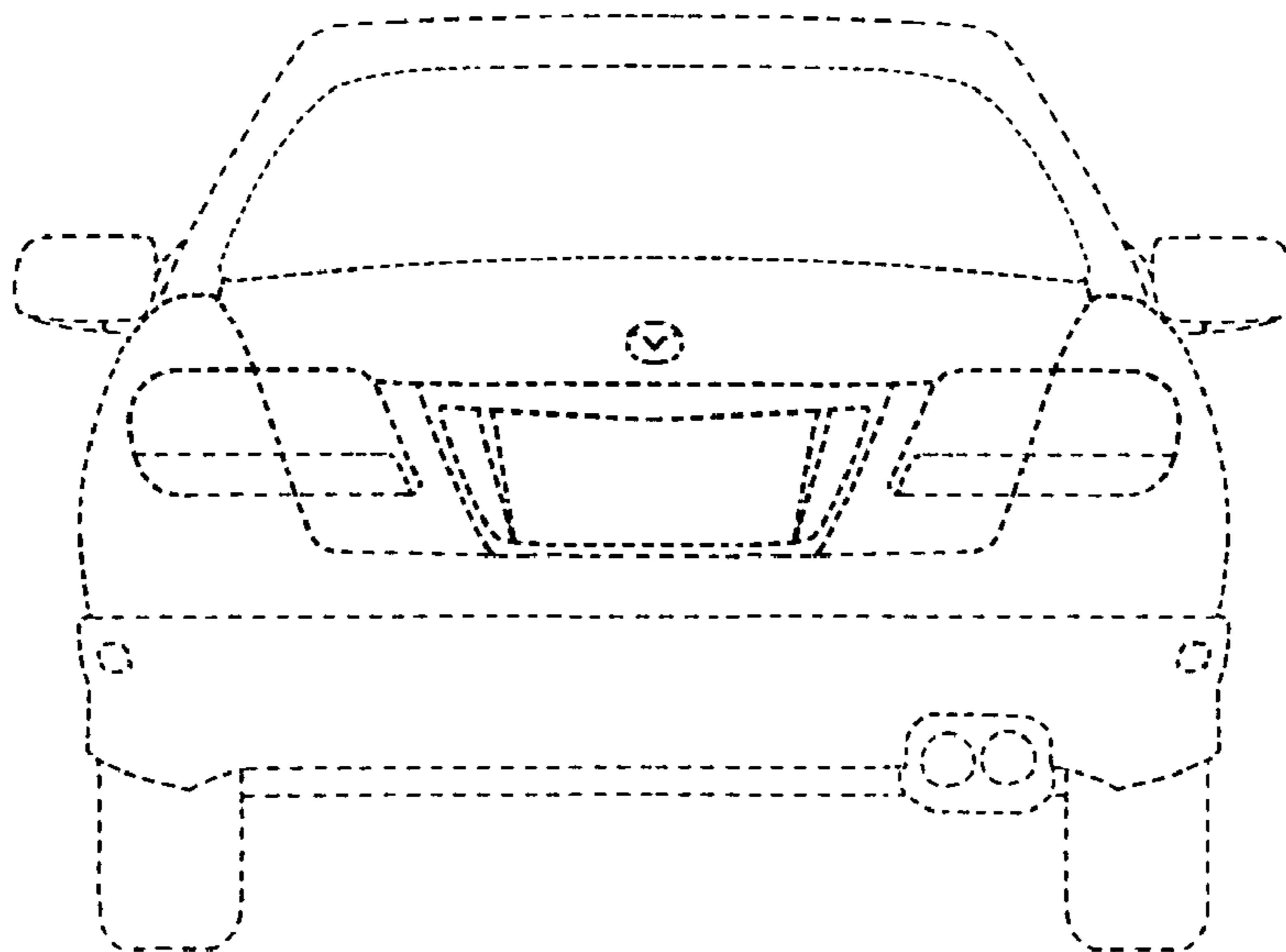

FIG. 9



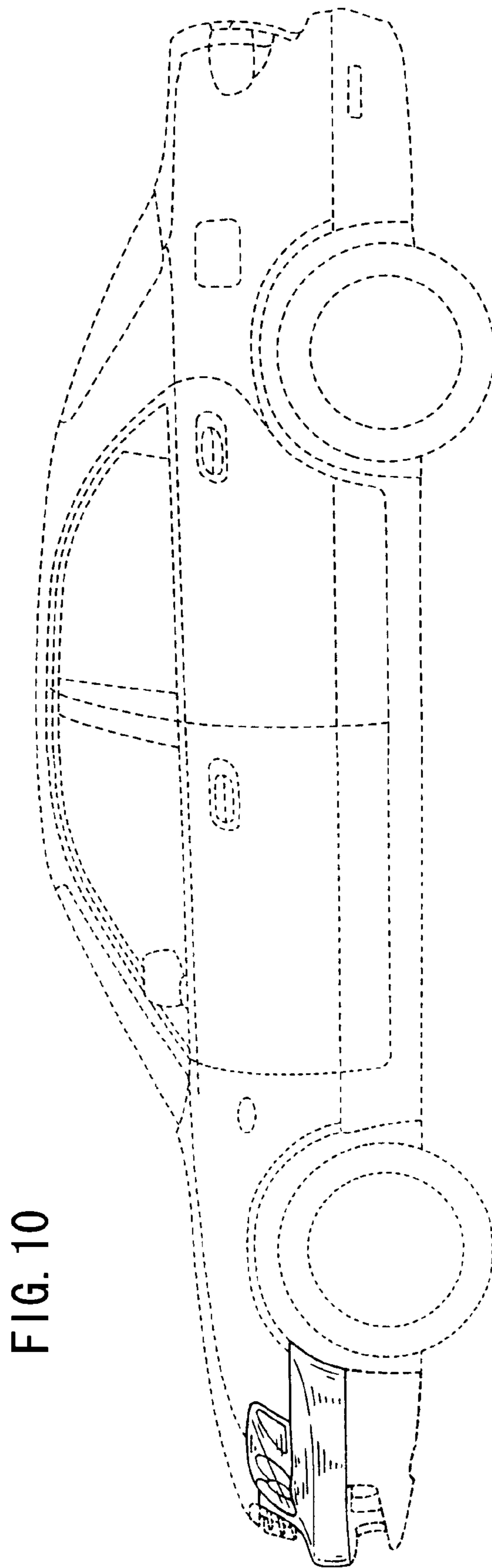

FIG. 10

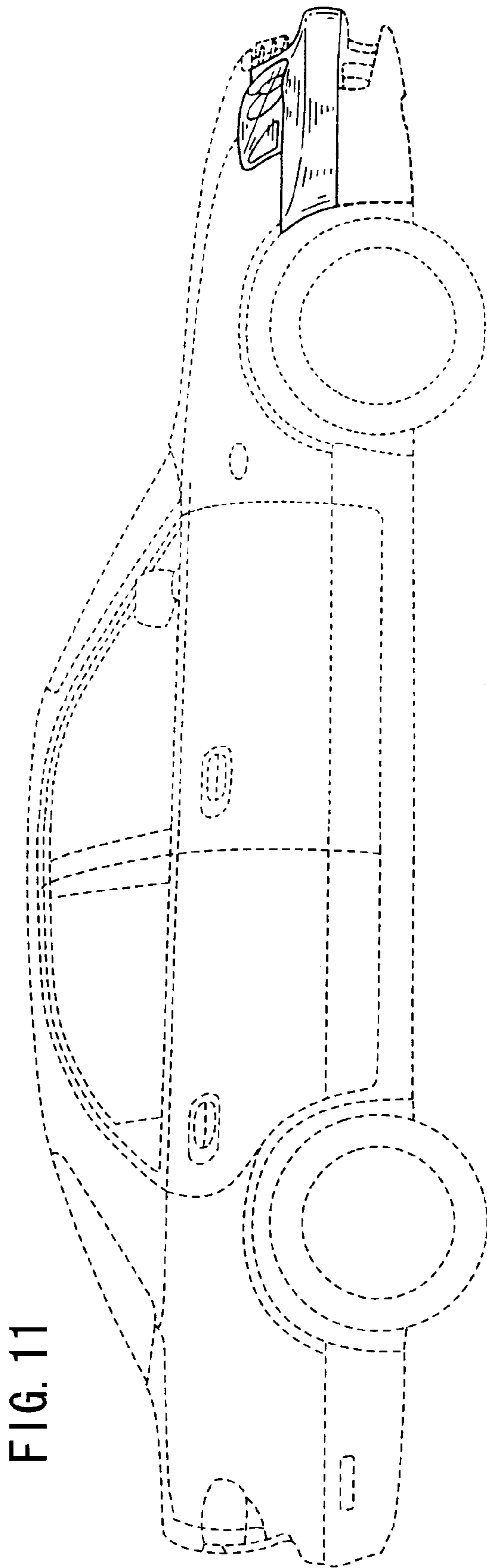

FIG. 11

FIG. 12

