



US00D446178S

(12) **United States Design Patent**  
**Akashi et al.**

(10) **Patent No.:** **US D446,178 S**

(45) **Date of Patent:** **\*\* Aug. 7, 2001**

(54) **DOOR FRAME PORTION OF A VEHICLE**

(75) Inventors: **Naoyuki Akashi; Steve Jennes**, both of  
Cerritos, CA (US)

(73) Assignee: **Isuzu Motors Limited**, Tokyo (JP)

(\*\*) Term: **14 Years**

(21) Appl. No.: **29/132,301**

(22) Filed: **Nov. 6, 2000**

(51) **LOC (7) Cl.** ..... **12-16**

(52) **U.S. Cl.** ..... **D12/196**

(58) **Field of Search** ..... D12/90-92; 296/185,  
296/186

(56) **References Cited**

**U.S. PATENT DOCUMENTS**

D. 346,989	5/1994	Dolan	.....	D12/91
D. 397,961	9/1998	Mays et al.	.....	D12/91
D. 440,185	4/2001	Desmond et al.	.....	D12/91

**OTHER PUBLICATIONS**

Daihatsu 1999 Showcar SP4—photograph only.

*Primary Examiner*—Melody N. Brown

(74) *Attorney, Agent, or Firm*—Frishauf, Holtz, Goodman,  
Langer & Chick, P.C.

(57) **CLAIM**

The ornamental design for a door frame portion of a vehicle,  
as shown and described.

**DESCRIPTION**

FIG. 1 is a top, left, right side perspective view of a door  
frame portion of a vehicle, showing our new design;

FIG. 2 is a top, front, right side perspective view thereof;

FIG. 3 is a top plan view thereof;

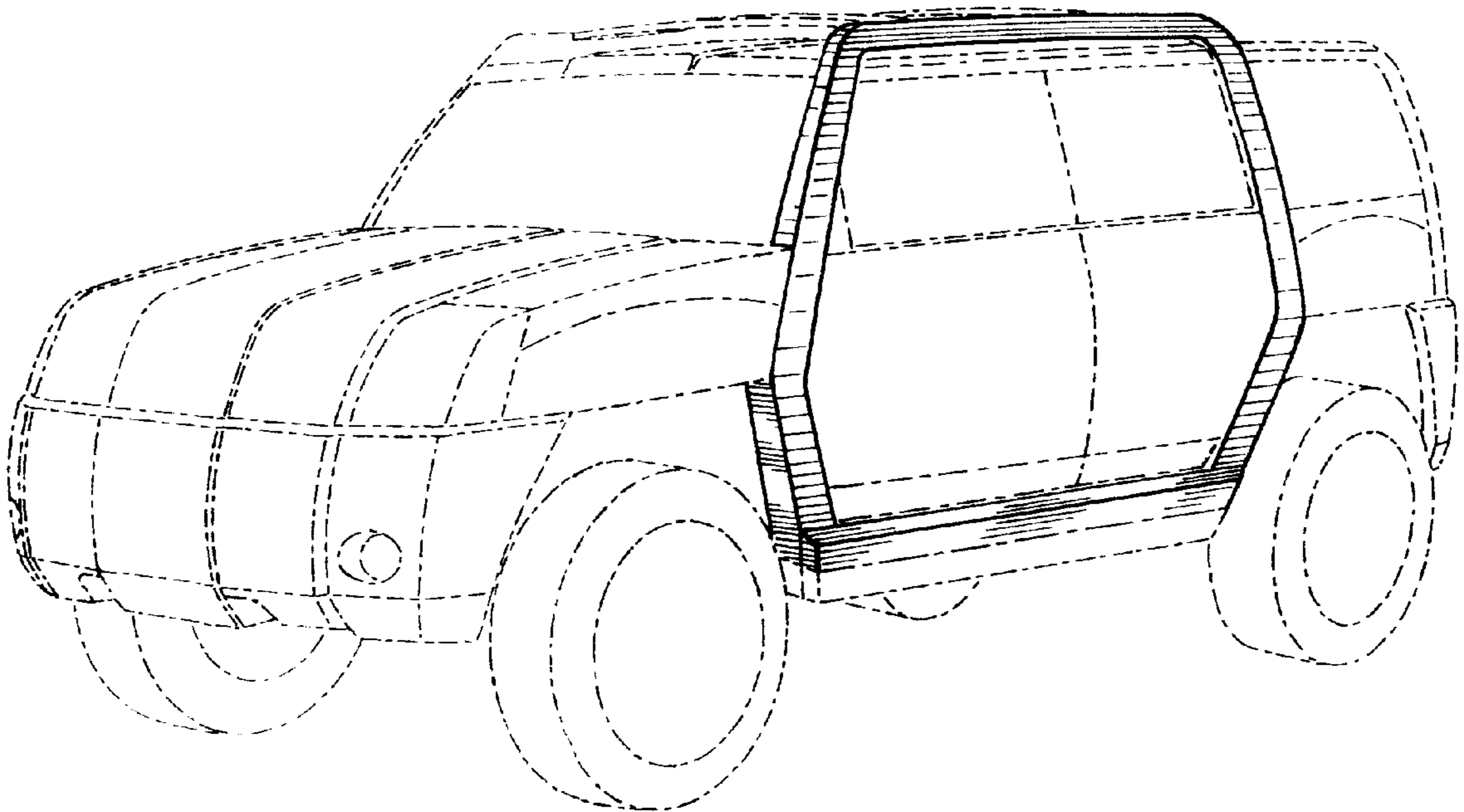
FIG. 4 is a front elevational view, the rear elevational view  
being a mirror image thereof;

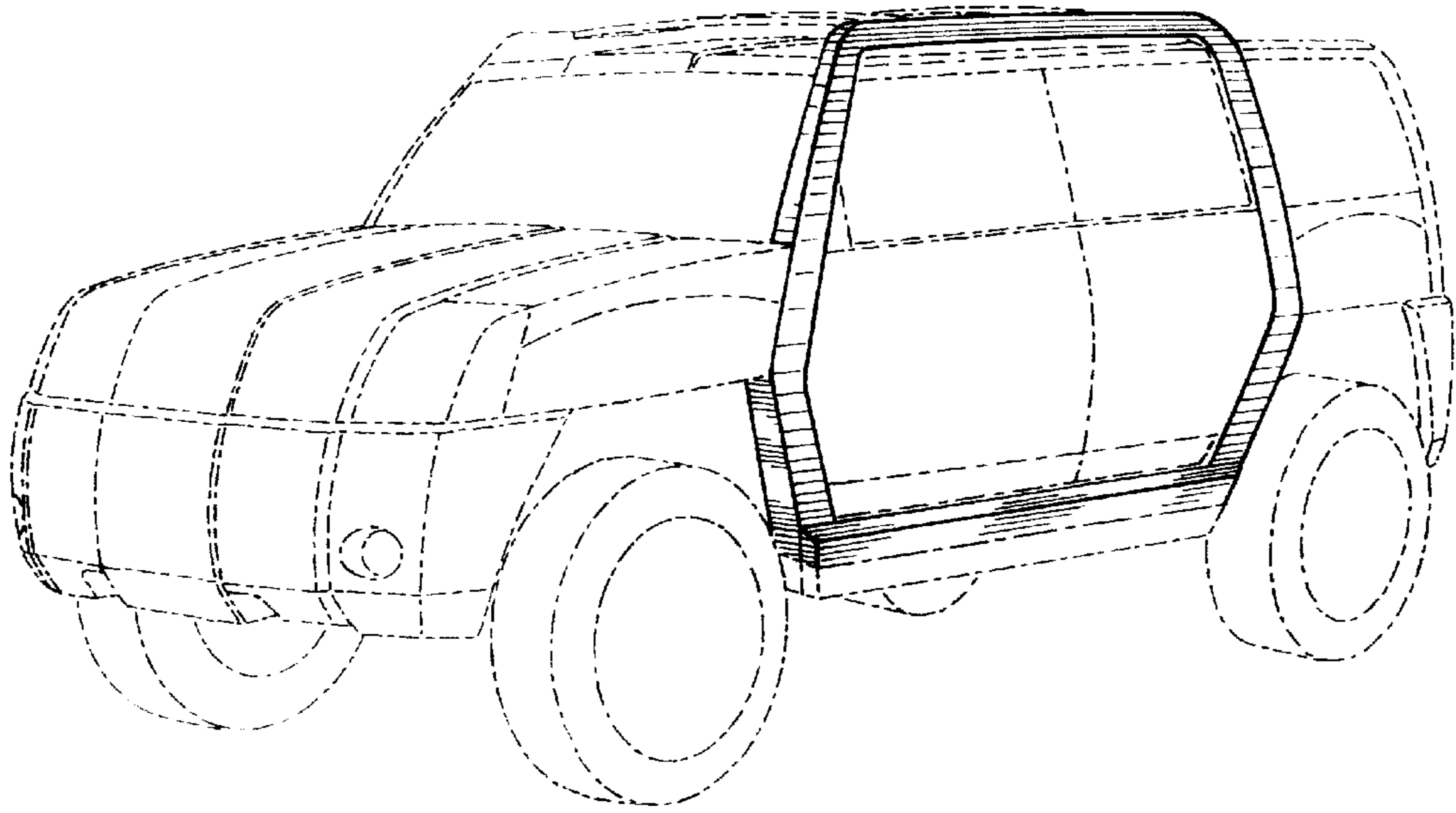
FIG. 5 is a left side elevational view thereof; and,

FIG. 6 is a right side elevational view thereof.

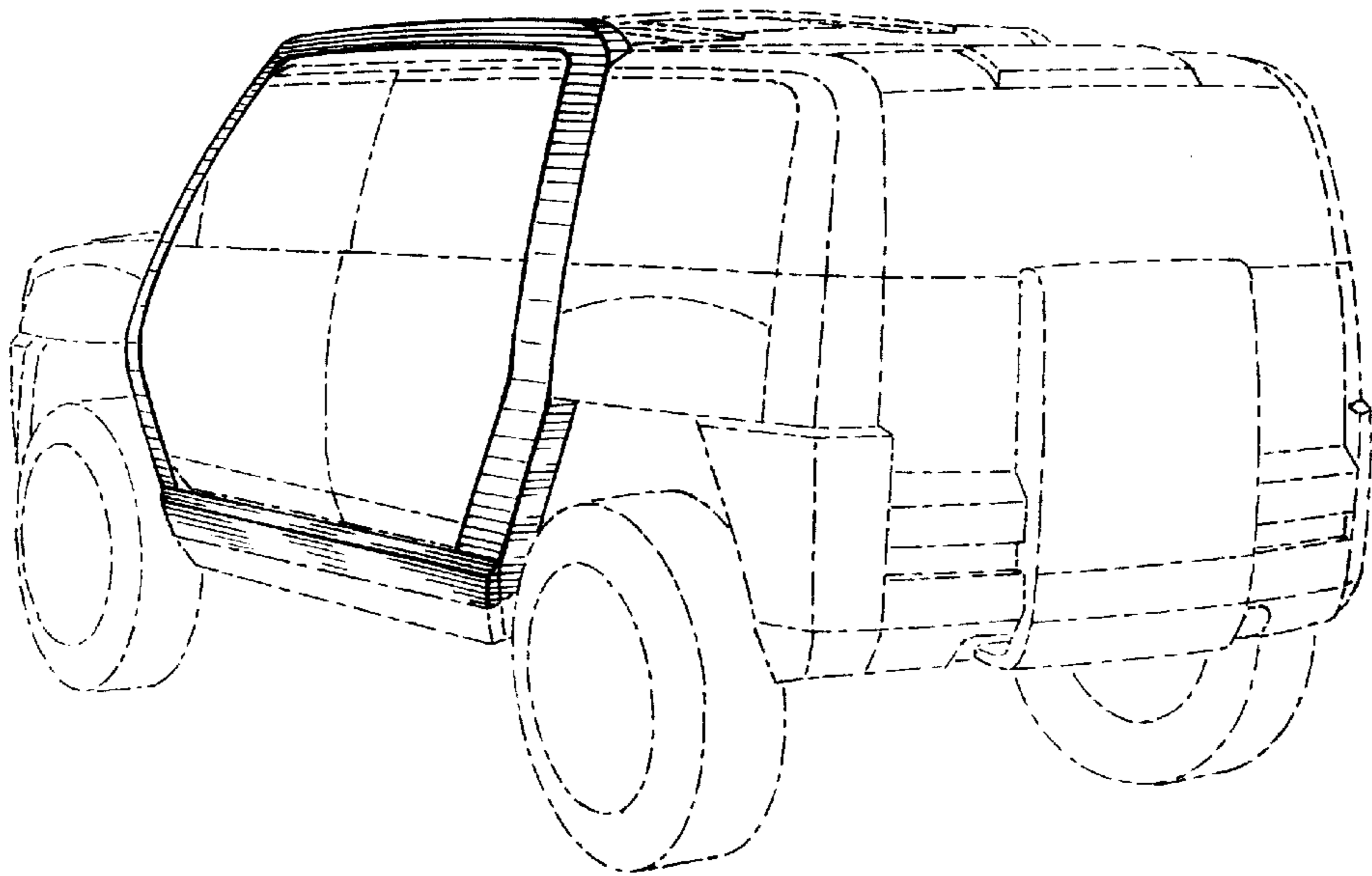
The broken line showing in the drawings is for illustrative  
purposes only and forms no part of the claimed design.

**1 Claim, 3 Drawing Sheets**

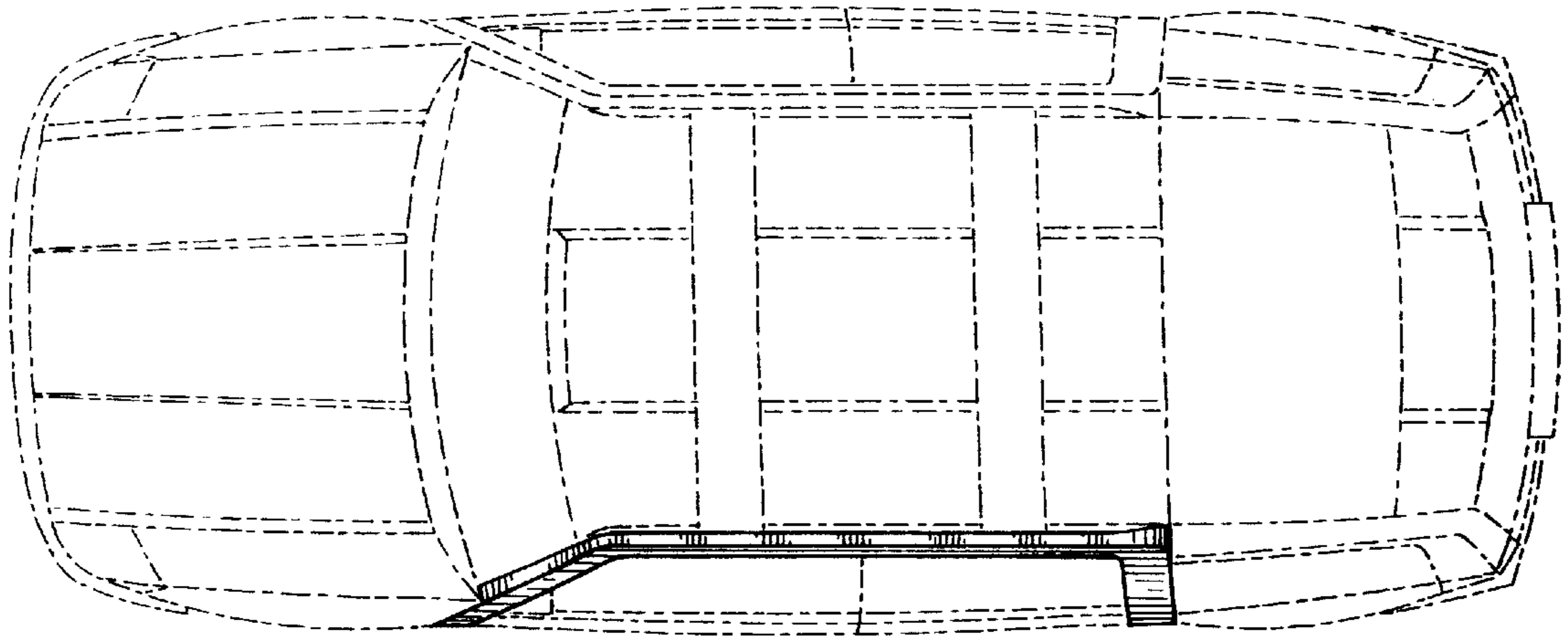




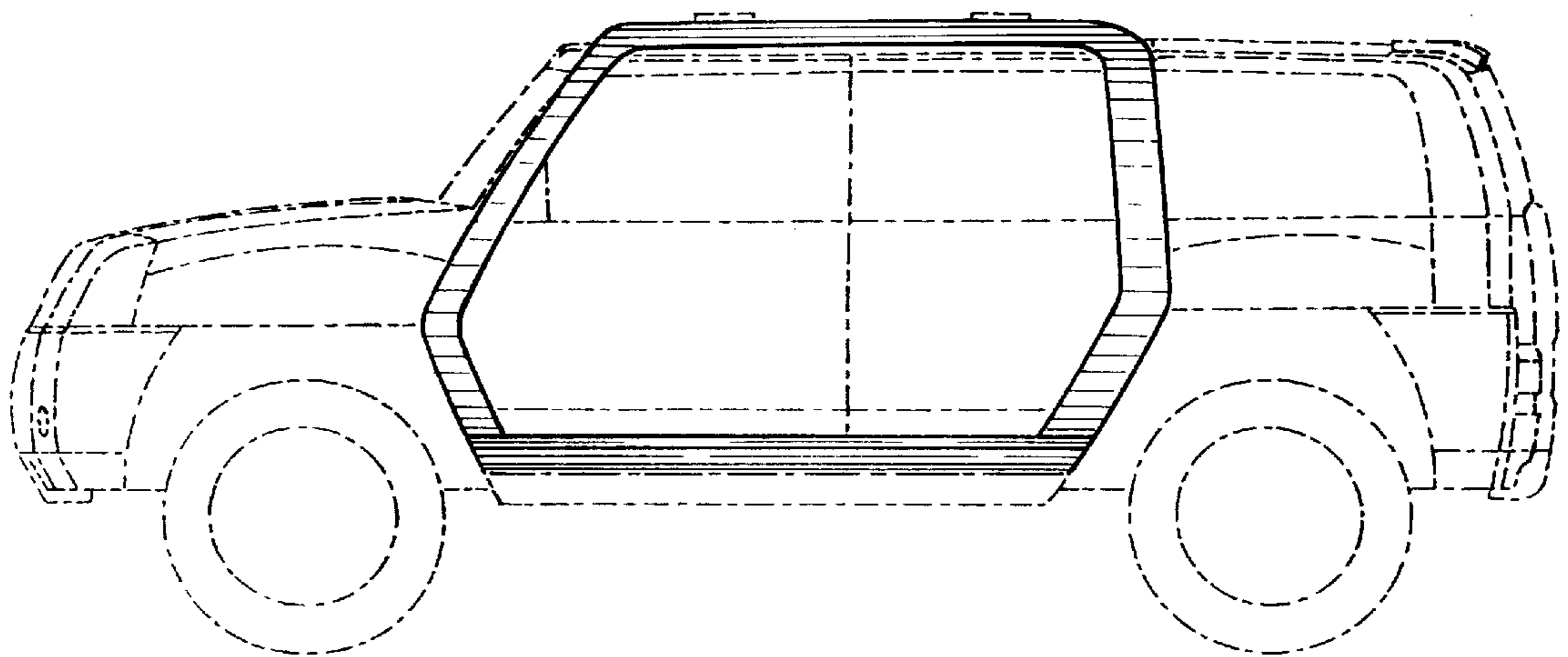
*Fig. 1*



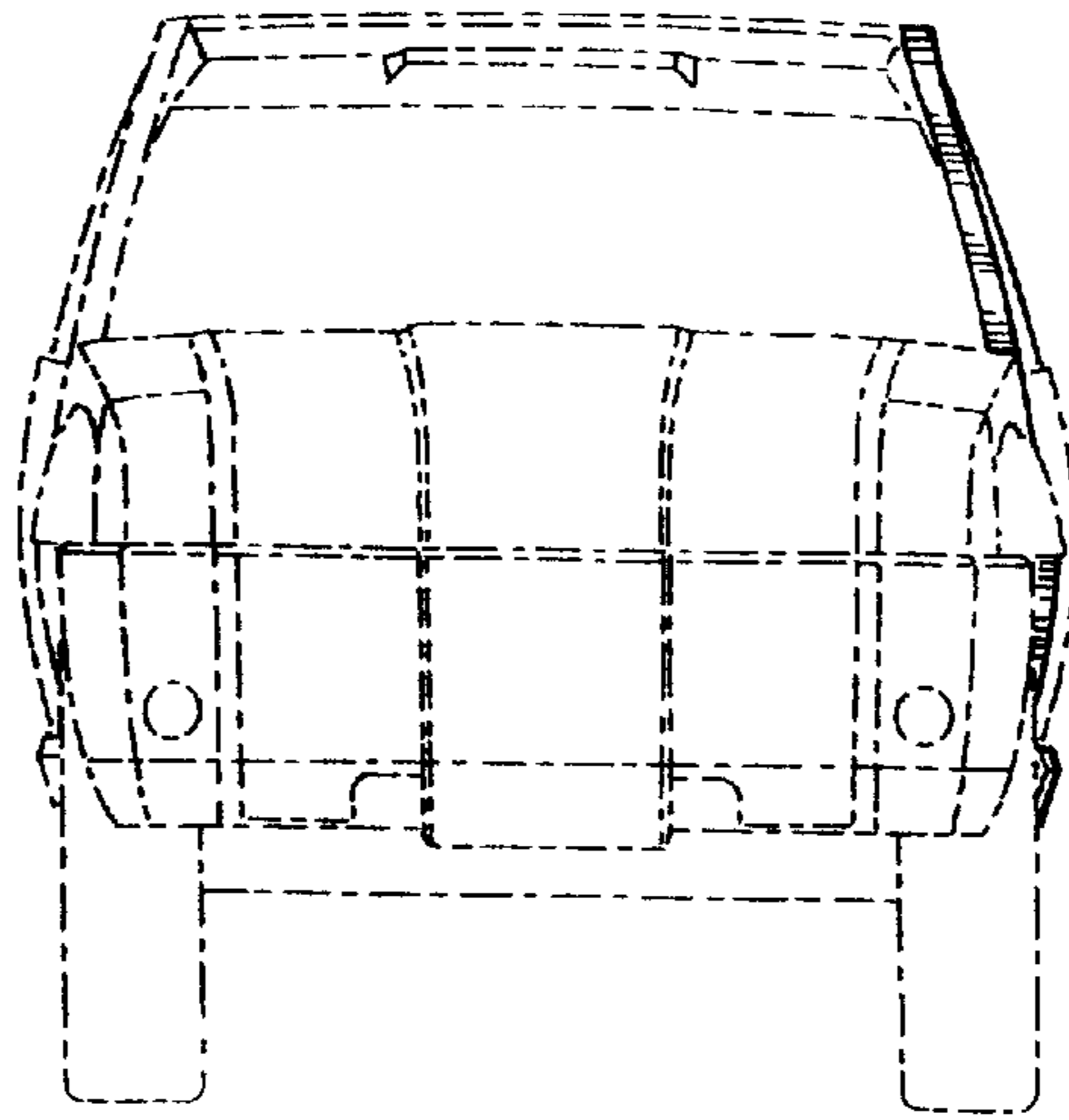
*Fig. 2*



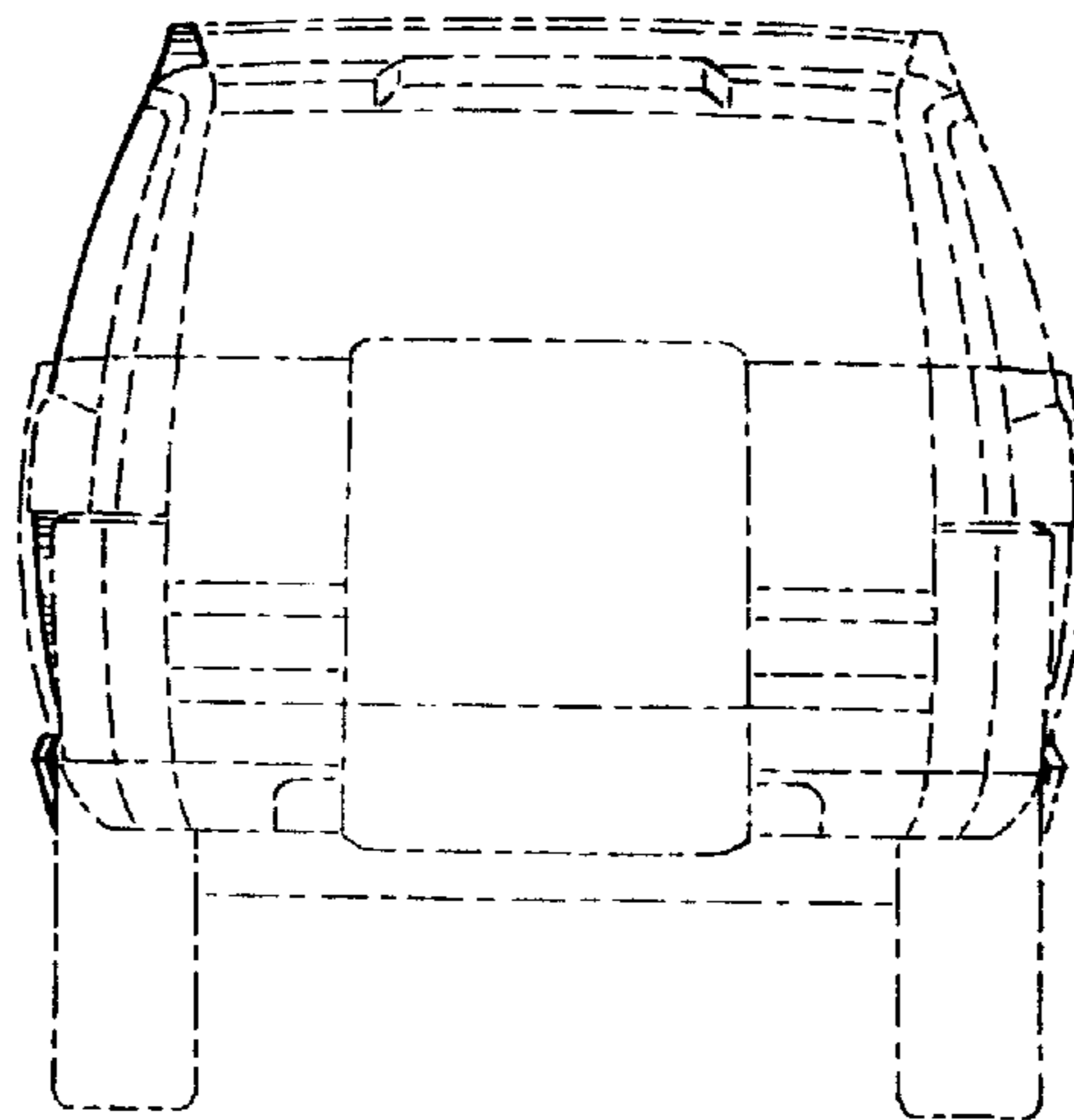
*Fig. 3*



*Fig. 4*



*Fig. 5*



*Fig. 6*