



US00D446177S

(12) **United States Design Patent**  
**Ueno**

(10) **Patent No.:** **US D446,177 S**  
(45) **Date of Patent:** **\*\* Aug. 7, 2001**

(54) **DISK ROTOR HUB OF DISK BRAKE FOR VEHICLES**

**FOREIGN PATENT DOCUMENTS**

(75) Inventor: **Tetsuyoshi Ueno**, Nagano-Ken (JP)  
(73) Assignee: **Nissin Kogyo Co., Ltd.**, Nagano-ken (JP)  
(\*\*) Term: **14 Years**

598371 4/1983 (JP) .  
598371 -  
Design 1 4/1983 (JP) .  
598371 -  
Design 2 4/1983 (JP) .  
598371 -  
Design 3 4/1983 (JP) .  
1025286 11/1998 (JP) .

(21) Appl. No.: **29/115,468**  
(22) Filed: **Dec. 16, 1999**

\* cited by examiner

*Primary Examiner*—Melody N. Brown  
(74) *Attorney, Agent, or Firm*—Sughrue, Mion, Zinn, Macpeak & Seas, PLLC

(30) **Foreign Application Priority Data**

Jun. 18, 1999 (JP) ..... 11-16099

(51) **LOC (7) Cl.** ..... **12-16**  
(52) **U.S. Cl.** ..... **D12/180**  
(58) **Field of Search** ..... D12/123, 180;  
D15/5; 74/606 R, 820; 188/24.12, 24.13,  
24.22, 24.11, 344, 73.46, 218 XL; 192/107 R,  
70.16

(57) **CLAIM**

The ornamental design for a disk rotor hub of disk brake for vehicles, as shown.

**DESCRIPTION**

FIG. 1 is a perspective view of the rear and one side of a disk rotor hub of disk brake for vehicles showing my new design; FIG. 2 is a side elevational view thereof; FIG. 3 is a side elevational view of the opposite side thereof; FIG. 4 is a top plan view thereof; FIG. 5 is a bottom plan view thereof; FIG. 6 is a rear elevational view thereof; and, FIG. 7 is a front elevational view thereof.

(56) **References Cited**

**U.S. PATENT DOCUMENTS**

D. 402,995 \* 12/1998 Hakamata ..... D15/5  
D. 402,996 \* 12/1998 Watanabe ..... D15/5  
D. 413,092 \* 8/1999 Johnson et al. .... D12/180  
D. 419,934 \* 1/2000 DiBella ..... D12/180

**1 Claim, 2 Drawing Sheets**

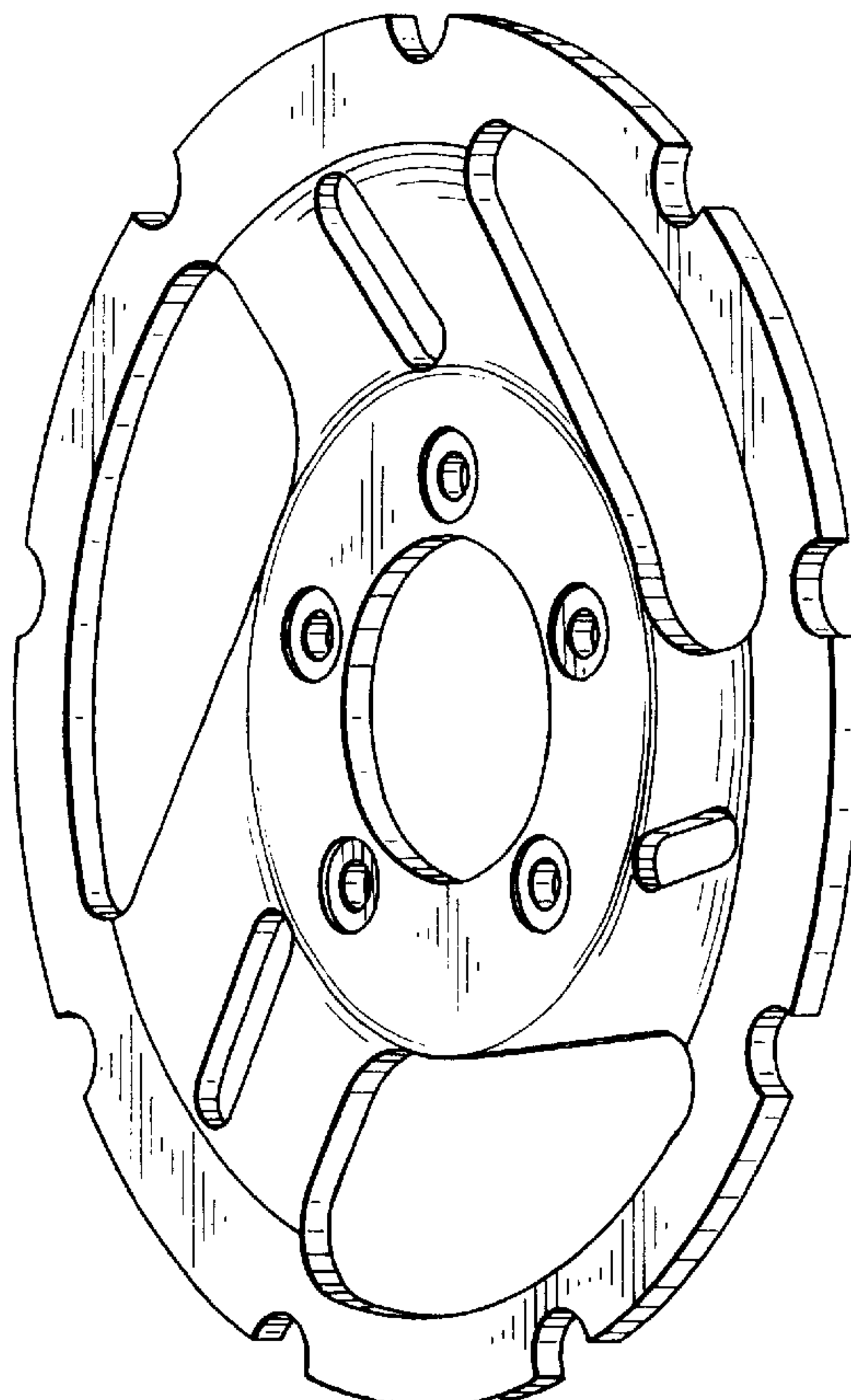

*FIG. 1*

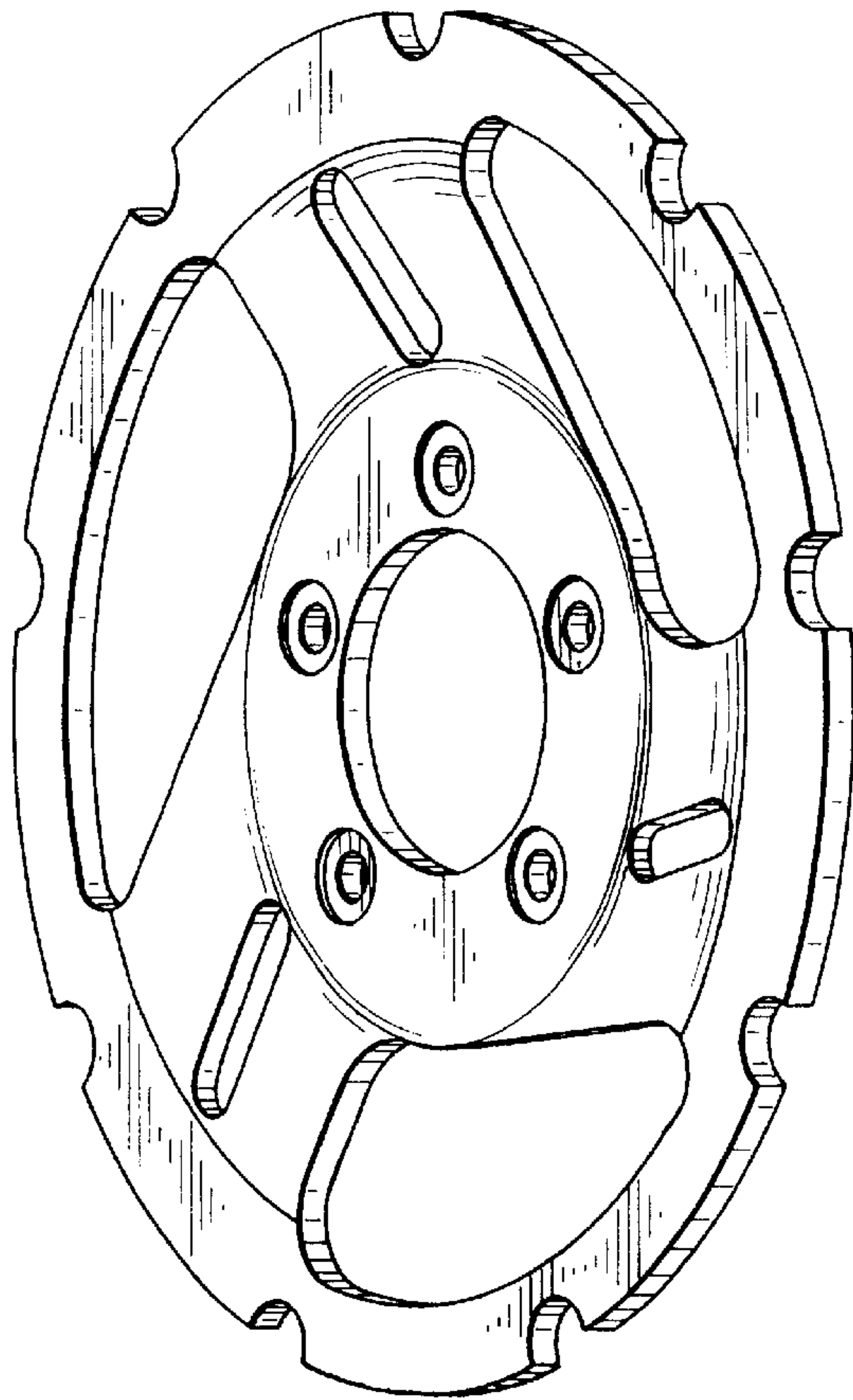

*FIG. 2*



*FIG. 3*

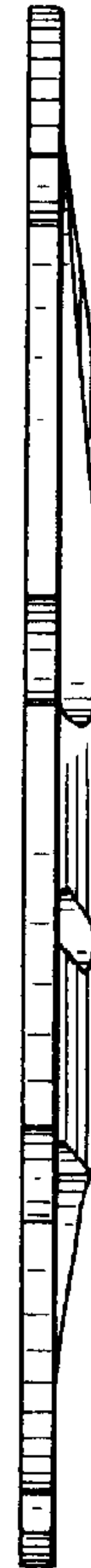

*FIG. 4*



*FIG. 5*

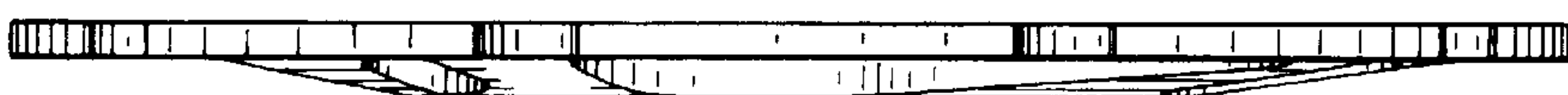

**FIG. 6**

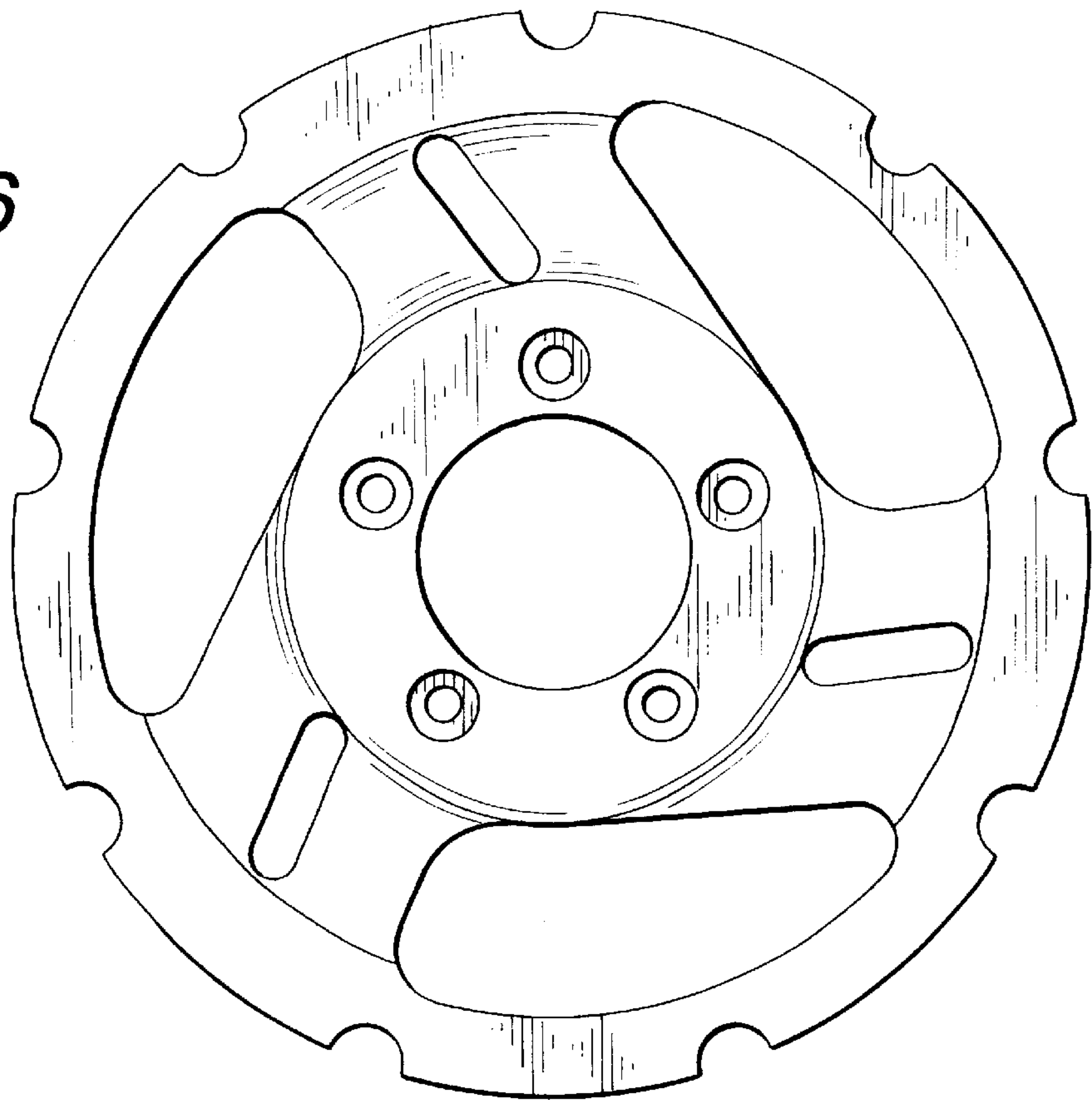

**FIG. 7**

