



US00D446176S

(12) **United States Design Patent**
Akashi et al.

(10) **Patent No.:** **US D446,176 S**

(45) **Date of Patent:** **** Aug. 7, 2001**

(54) **HOOD PORTION OF A VEHICLE**

(75) Inventors: **Naoyuki Akashi; Steve Jennes**, both of
Cerritos, CA (US)

(73) Assignee: **Isuzu Motors Limited**, Tokyo (JP)

(**) Term: **14 Years**

(21) Appl. No.: **29/132,304**

(22) Filed: **Nov. 6, 2000**

(51) **LOC (7) Cl.** **12-16**

(52) **U.S. Cl.** **D12/173**

(58) **Field of Search** D12/173, 90-92,
D12/196; 296/69.2, 69.21

(56) **References Cited**

U.S. PATENT DOCUMENTS

- D. 427,122 * 1/2000 Hoyle, Jr. D12/173
- D. 430,084 * 8/2000 Hoyle, Jr. D12/173
- D. 436,563 * 1/2001 Minowa et al. D12/91

OTHER PUBLICATIONS

Daihatsu 1999 Showcar SP4—photograph only.

* cited by examiner

Primary Examiner—Melody N. Brown

(74) *Attorney, Agent, or Firm*—Frishauf, Holtz, Goodman,
Langer & Chick, P.C.

(57) **CLAIM**

The ornamental design for a hood portion of a vehicle, as shown and described.

DESCRIPTION

FIG. 1 is a top, front, right side perspective view of a hood portion of a vehicle, showing our new design;

FIG. 2 is a top plan view thereof;

FIG. 3 is a front elevational view thereof; and,

FIG. 4 is a right side elevational view, the left side elevational view being a mirror image thereof.

The broken line showing in the drawings is for illustrative purposes only and forms no part of the claimed design.

1 Claim, 2 Drawing Sheets

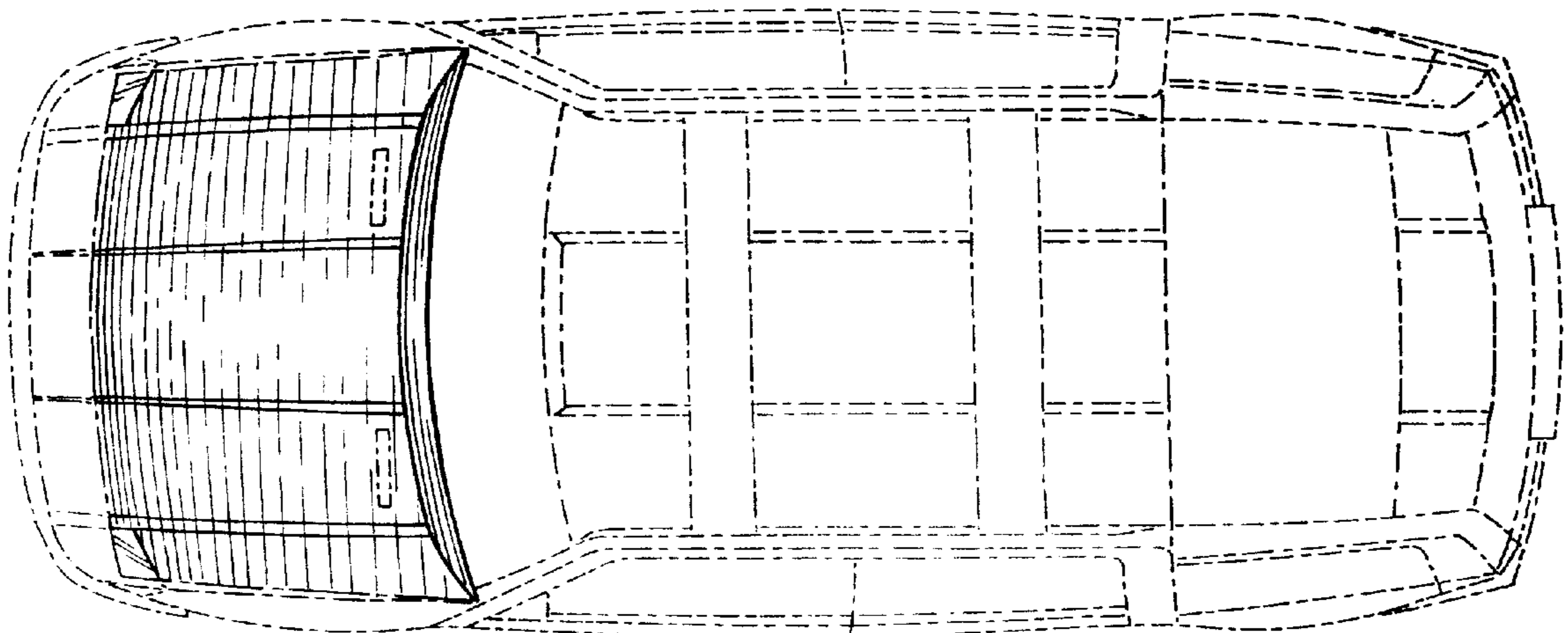

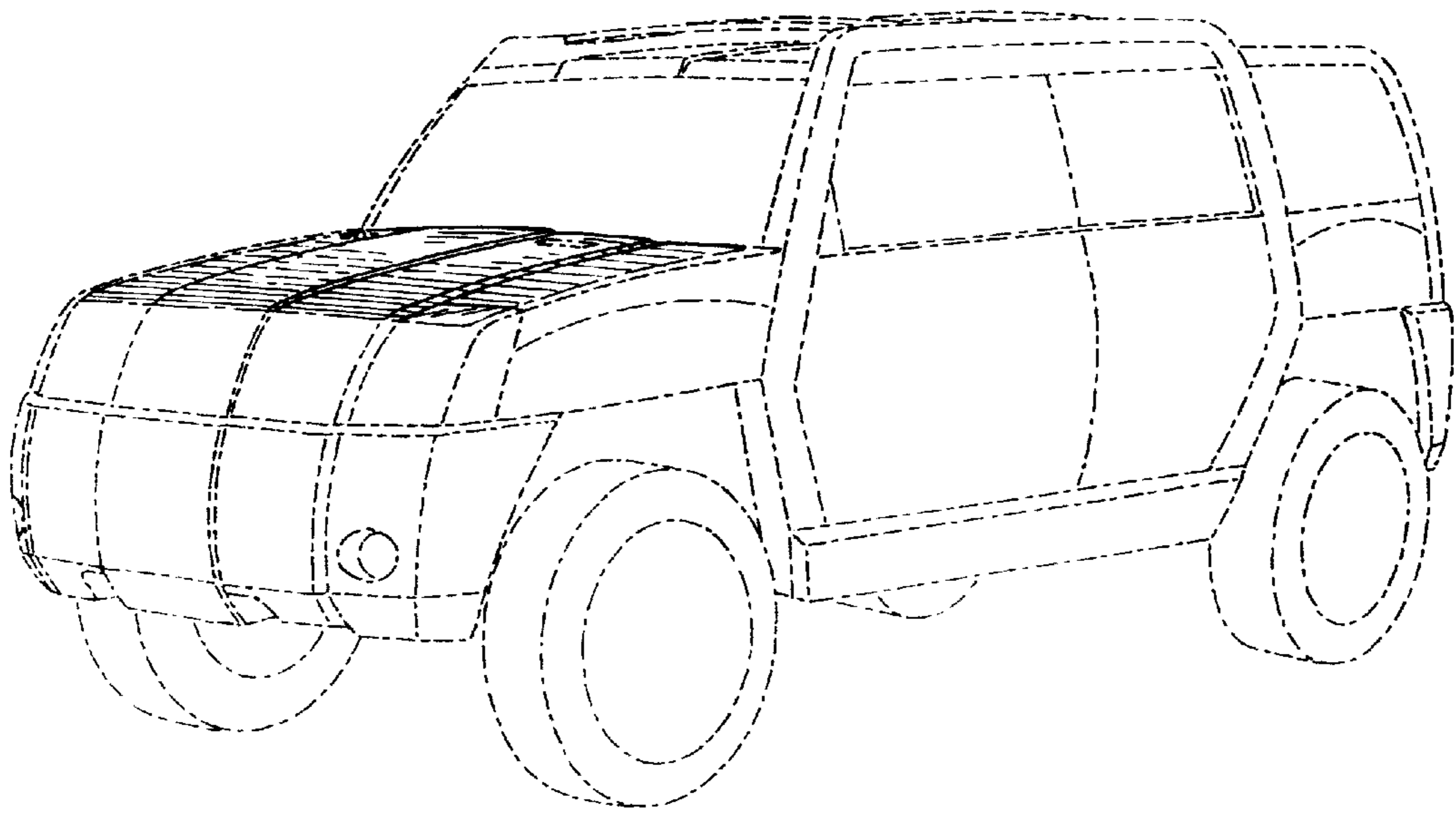

Fig. 1

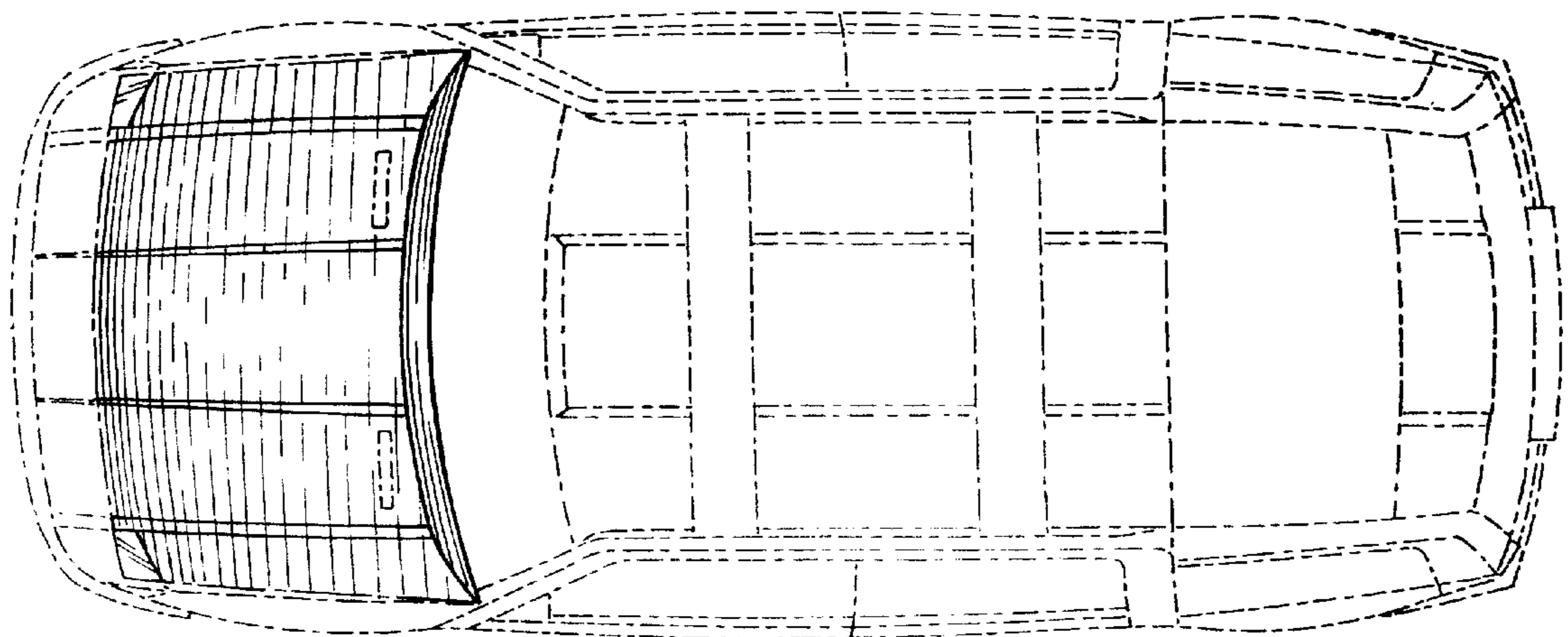

Fig. 2

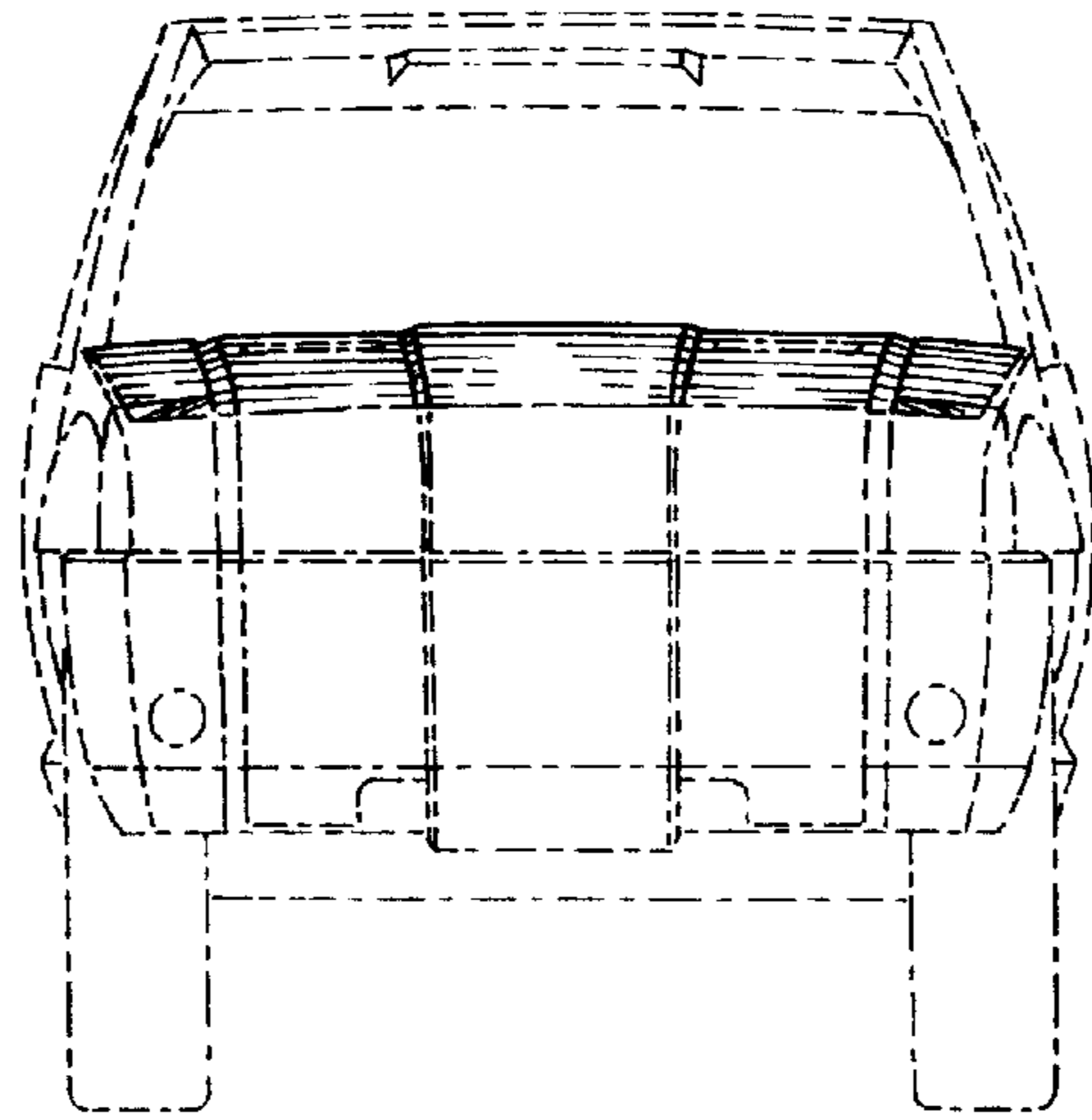

Fig. 3

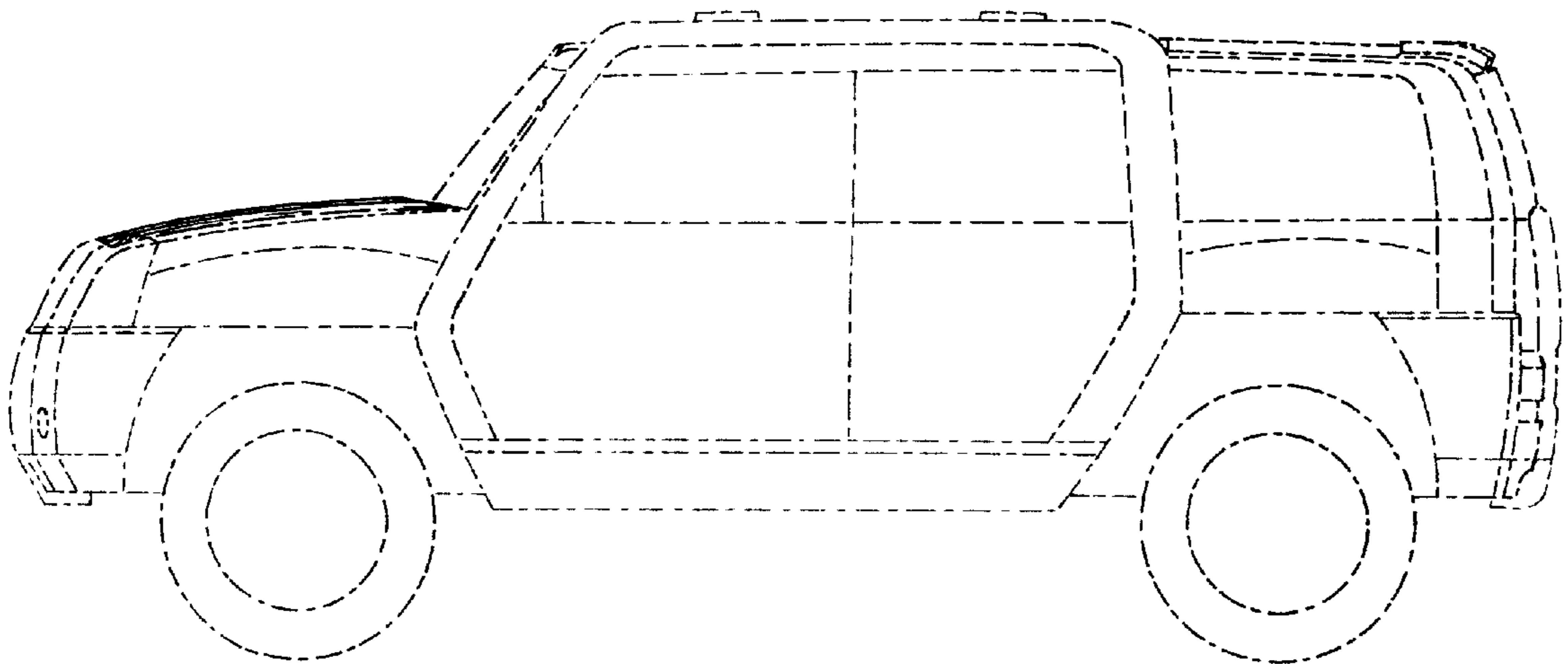

Fig. 4