



US00D445838S

(12) **United States Design Patent**
Ishii et al.

(10) **Patent No.:** **US D445,838 S**

(45) **Date of Patent:** **** Jul. 31, 2001**

(54) **GAME MACHINE**

(75) Inventors: **Takaaki Ishii; Hirofumi Mamitsu,**
both of Kobe; **Shinya Ishida,**
Kokubunji, all of (JP)

(73) Assignee: **Konami Co., Ltd.,** Tokyo (JP)

(**) Term: **14 Years**

(21) Appl. No.: **29/125,115**

(22) Filed: **Jun. 19, 2000**

(51) **LOC (7) Cl.** **21-01**

(52) **U.S. Cl.** **D21/325**

(58) **Field of Search** D21/324-333;
463/1, 6, 30-35, 46, 47, 49-52; 273/148 B,
440, 454, 455, 456, 459, 460, 461, 441,
317.1-317.9

(56) **References Cited**

U.S. PATENT DOCUMENTS

- D. 361,095 * 8/1995 O'Donnell D21/325
- D. 419,606 * 1/2000 Toriyama D21/325

- 4,474,372 * 10/1984 Karasawa 273/442
- 5,558,340 * 9/1996 Ibe et al. 273/448
- 5,795,224 * 8/1998 Yoshida 463/2
- 5,820,460 * 10/1998 Fulton 463/13
- 5,967,892 * 10/1999 Shoemaker, Jr. 463/7

* cited by examiner

Primary Examiner—Prabhakar Deshmukh

(74) *Attorney, Agent, or Firm*—Jordan and Hamburg LLP

(57) **CLAIM**

The ornamental design for a game machine, as shown and described.

DESCRIPTION

FIG. 1 is a perspective view of a game machine;
FIG. 2 is a front view thereof;
FIG. 3 is a rear view thereof;
FIG. 4 is a right side view thereof;
FIG. 5 is a left view thereof;
FIG. 6 is a top view thereof; and,
FIG. 7 is a bottom view thereof.

1 Claim, 7 Drawing Sheets

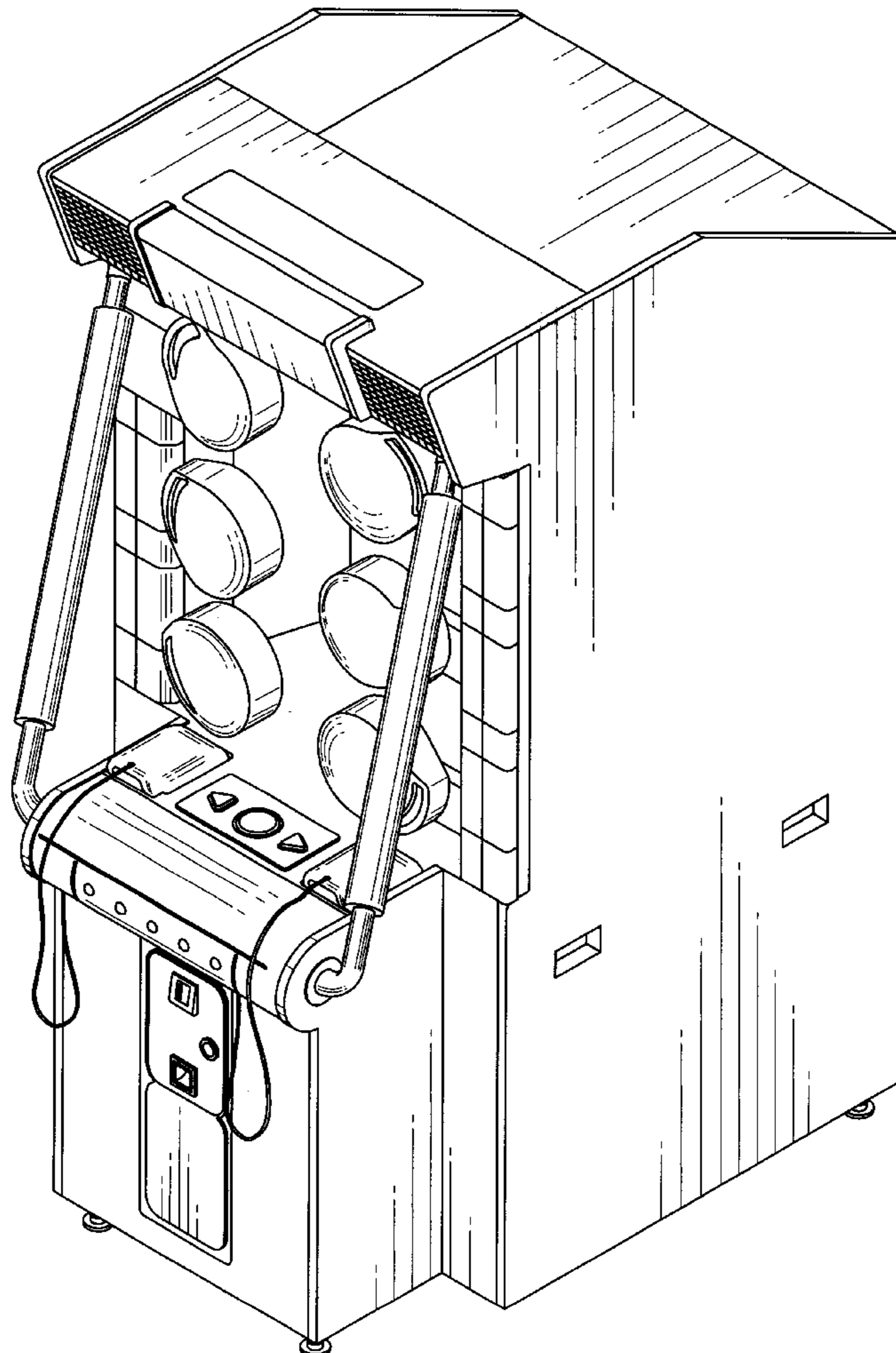

FIG. 1

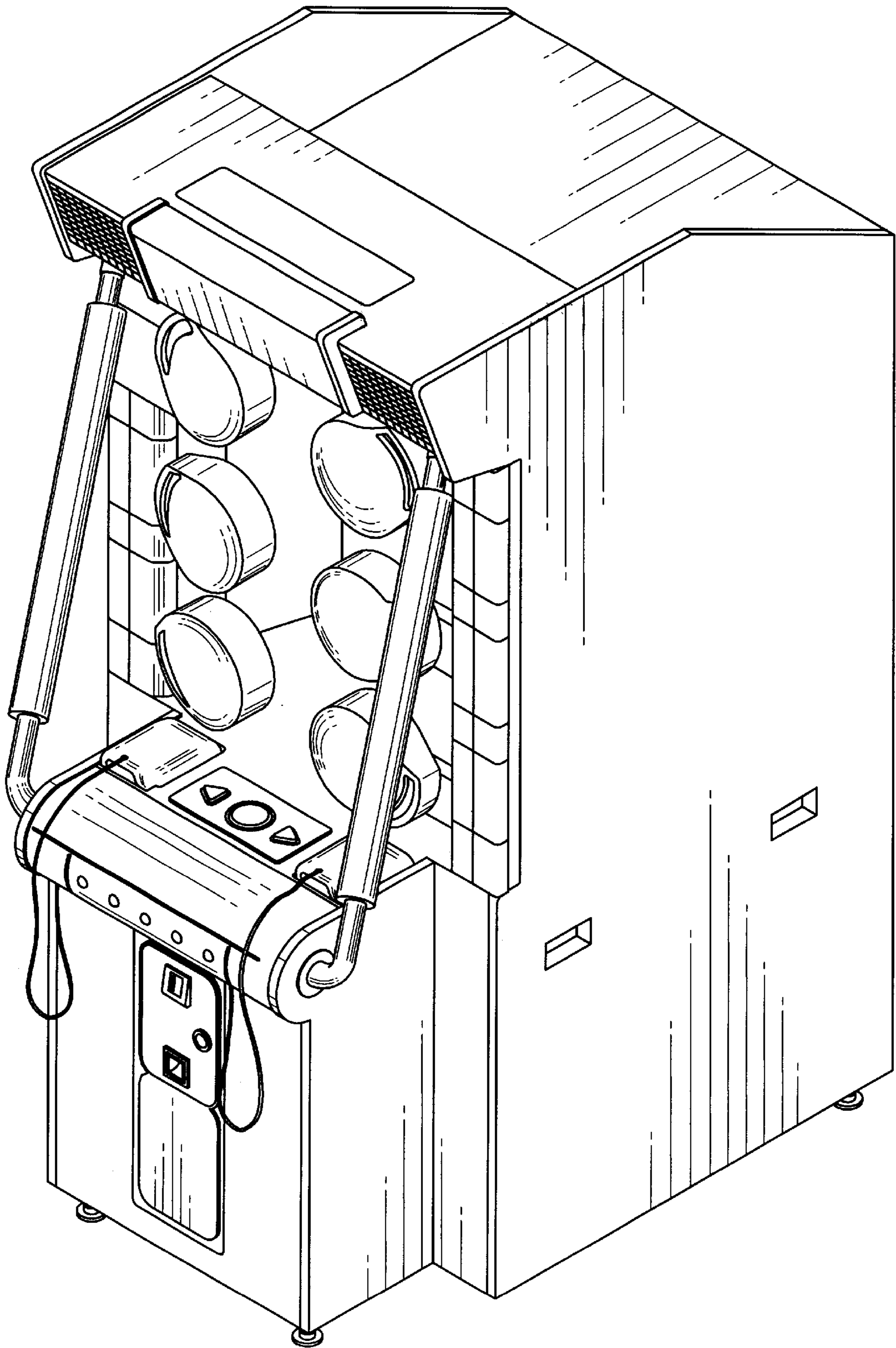

FIG. 2

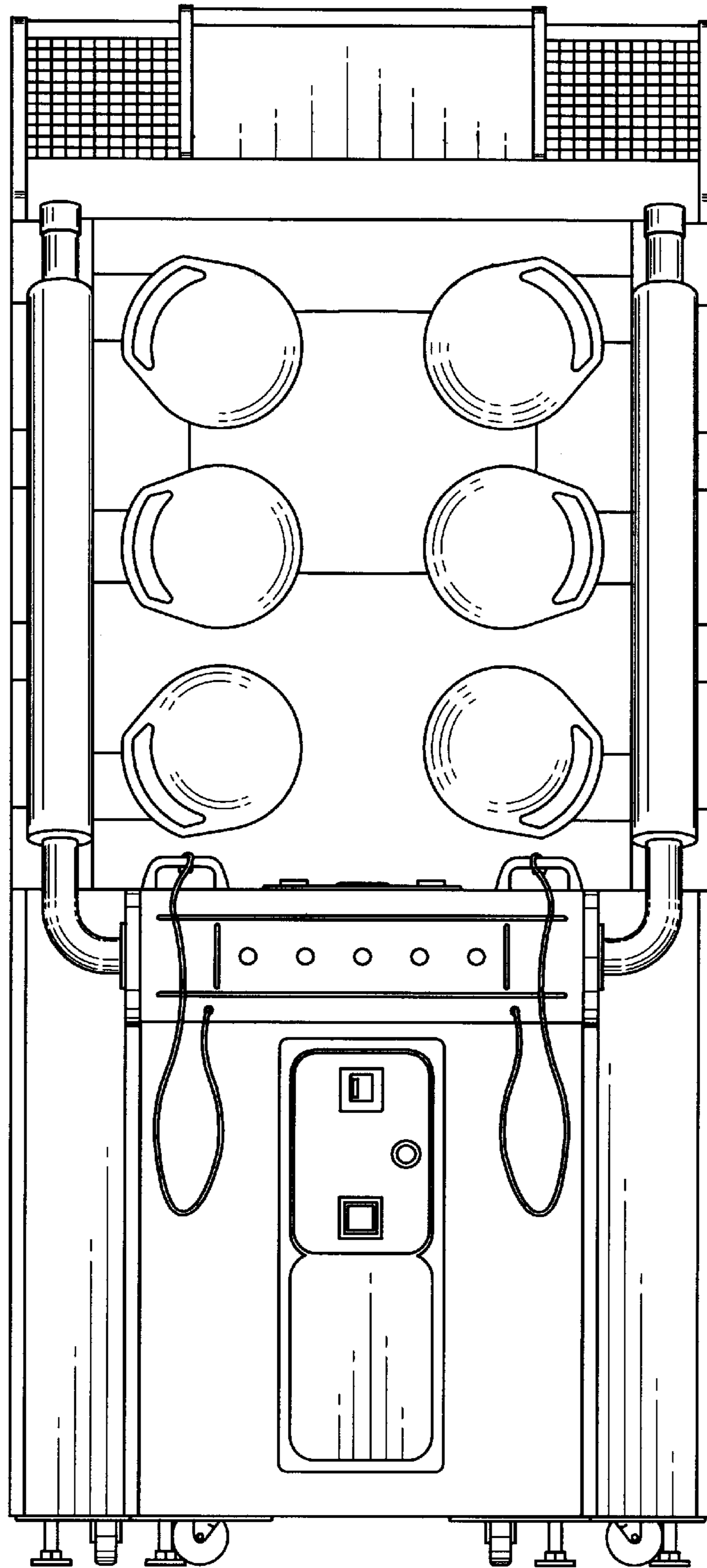

FIG. 3

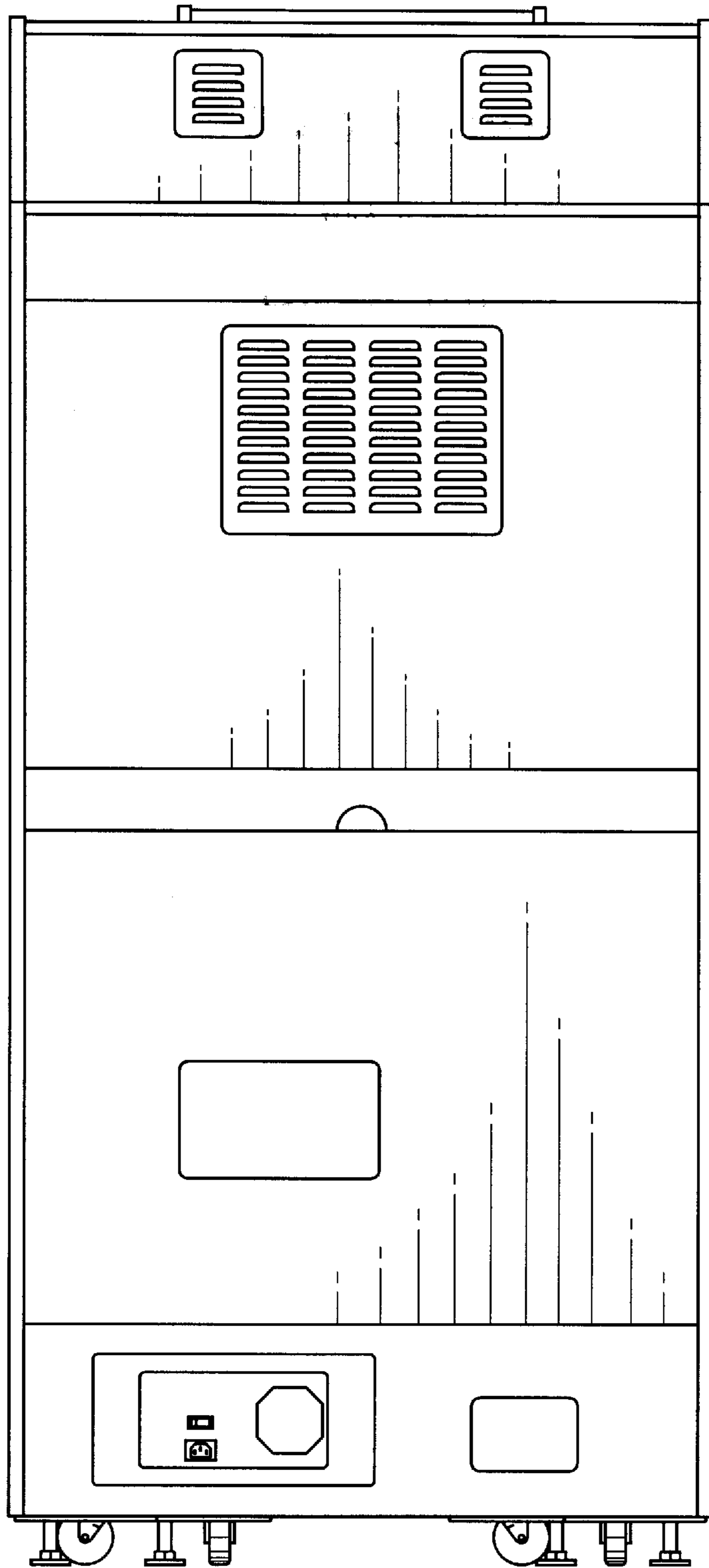

FIG. 4

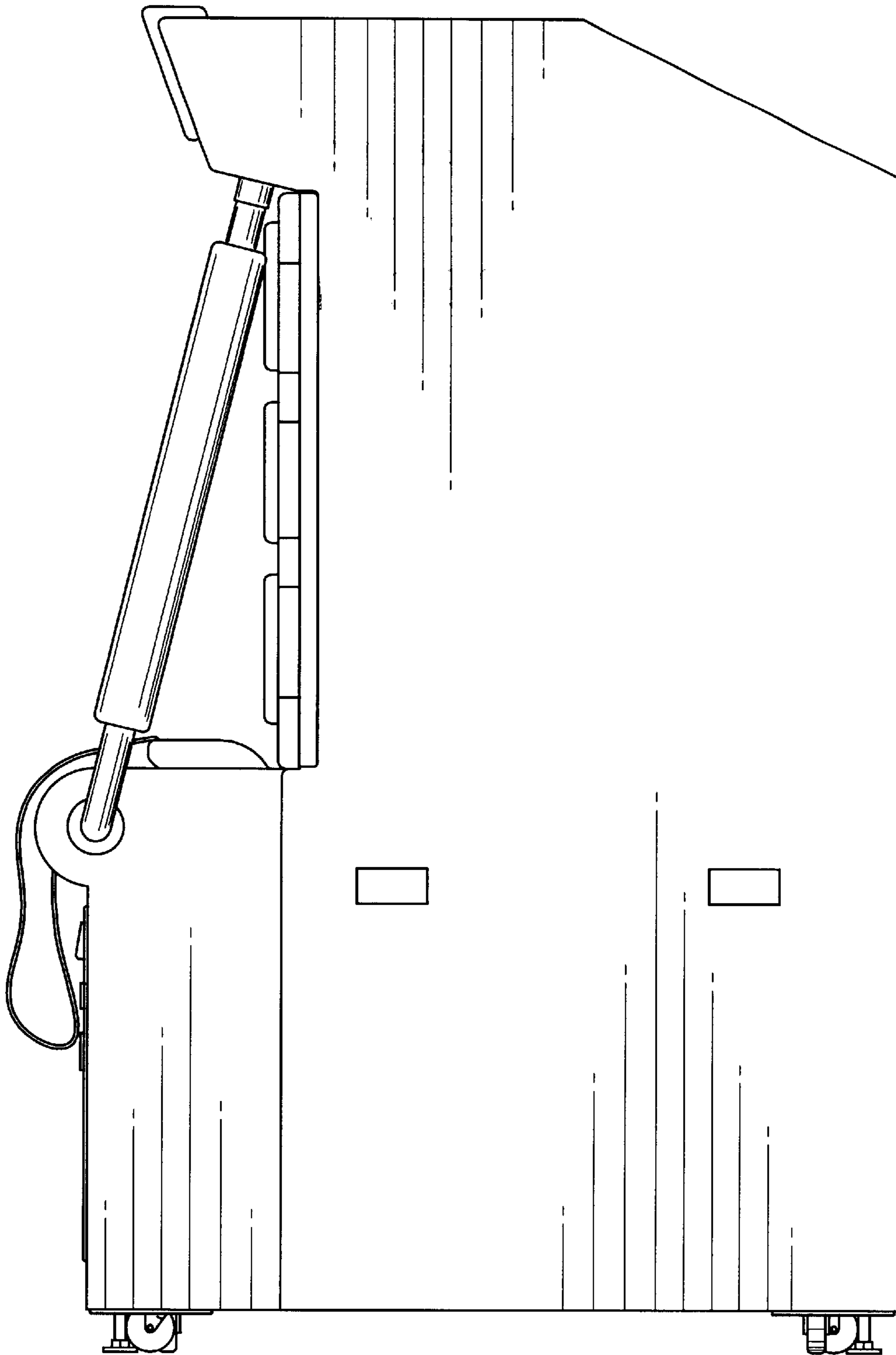

FIG. 5

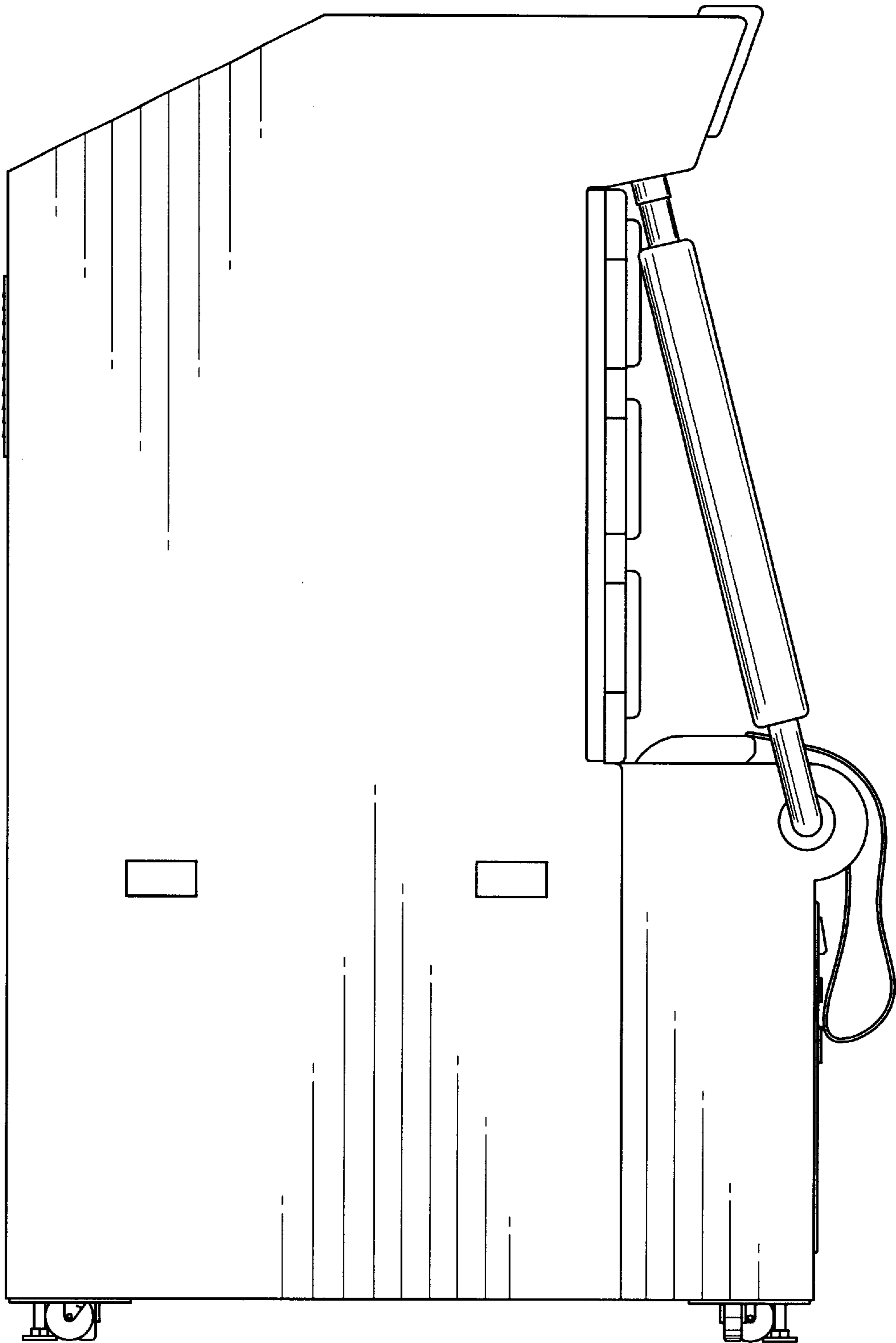

FIG. 6

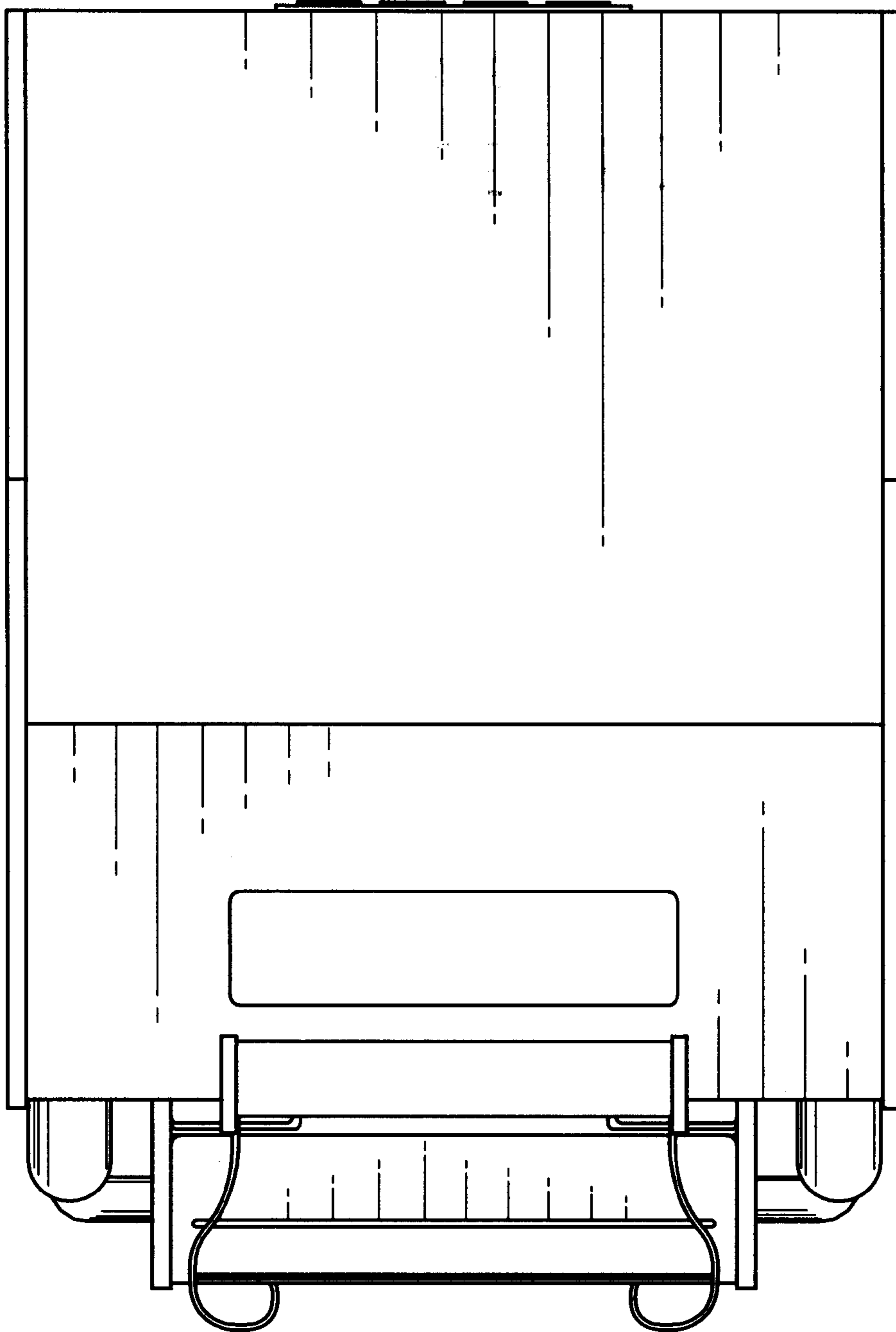

FIG. 7

