



US00D445837S

(12) **United States Design Patent**
Waterhouse

(10) **Patent No.:** **US D445,837 S**

(45) **Date of Patent:** **** Jul. 31, 2001**

(54) **TABLE TOP ADVERTISING MEDIA
SUPPORT WITH INDICIA MAGNIFYING
BASE**

5,943,173 8/1999 Waterhouse 359/802
6,081,393 6/2000 Waterhouse 359/802

* cited by examiner

(76) **Inventor:** **William H. Waterhouse**, P.O. Box
722274, Norman, OK (US) 73070

Primary Examiner—Marcus A. Jackson
(74) *Attorney, Agent, or Firm*—Robert K. Rhea

(**) **Term:** **14 Years**

(57) **CLAIM**

(21) **Appl. No.:** **29/133,662**

A table top advertising media support with indicia magnifying base, as shown and described.

(22) **Filed:** **Dec. 4, 2000**

DESCRIPTION

(51) **LOC (7) Cl.** **19-08**

(52) **U.S. Cl.** **D20/40**

(58) **Field of Search** D20/10, 15, 39,
D20/40, 41; 40/1, 124, 124.1, 124.2, 124.4,
152, 152.1, 642, 643, 624

FIG. 1 is an isometric view of a table top advertising media support with indicia magnifying base;
FIG. 2 is a top view thereof;
FIG. 3 is a side elevational view thereof, the view from the opposite side being a mirror image;
FIG. 4 is an end elevational view thereof, the view from the opposite side being a mirror image;
FIG. 5 is a bottom view thereof; and,
FIG. 6 is a fragmentary vertical cross sectional view, partially in elevation, taken substantially along the line 6—6 of FIG. 1.

(56) **References Cited**

U.S. PATENT DOCUMENTS

D. 350,566	*	9/1994	Pearson	D20/40
D. 375,980	*	11/1996	Current	D20/40
D. 383,497	*	9/1997	Robertson	D20/10
D. 407,119	*	3/1999	Kwan	D20/40

1 Claim, 3 Drawing Sheets

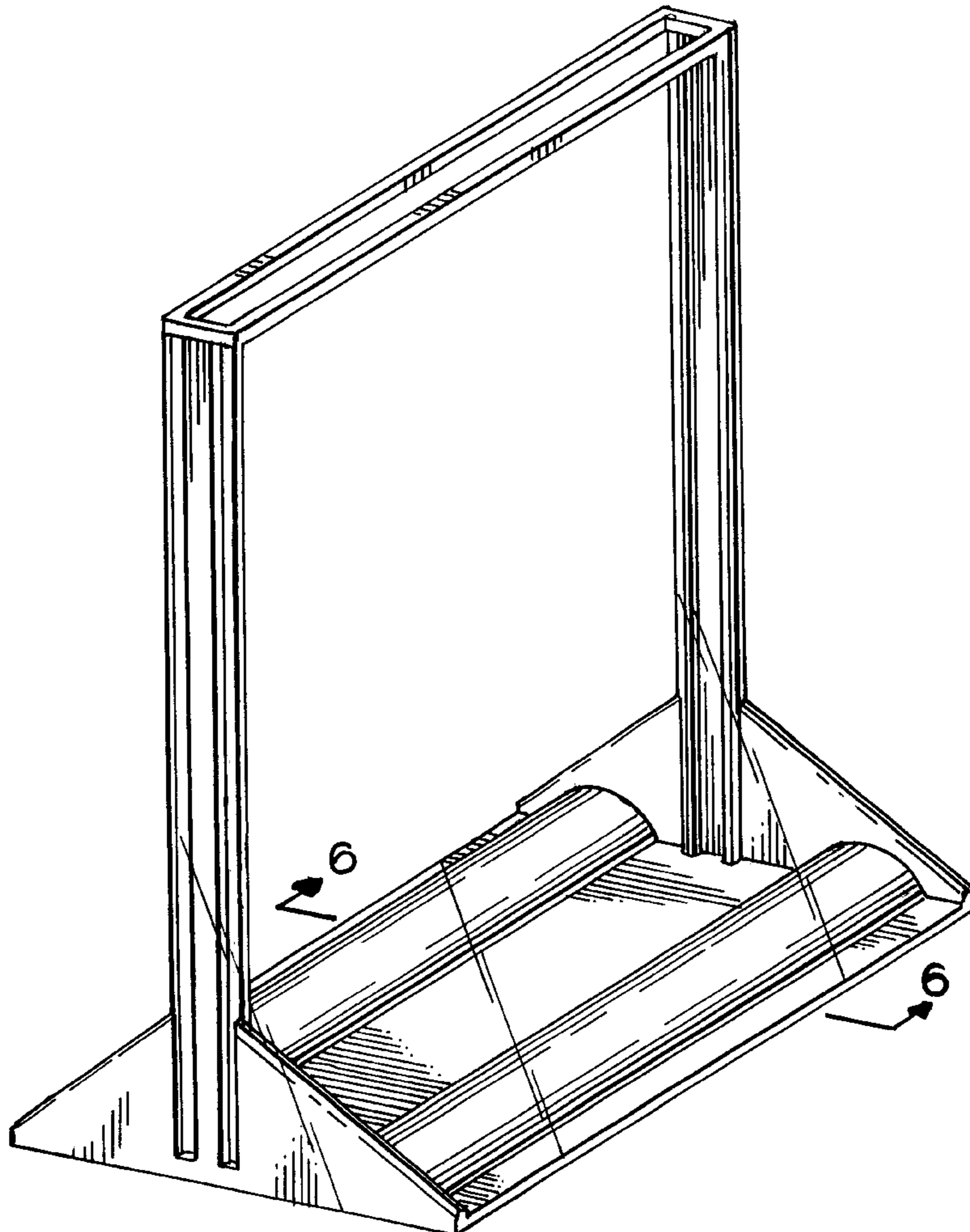

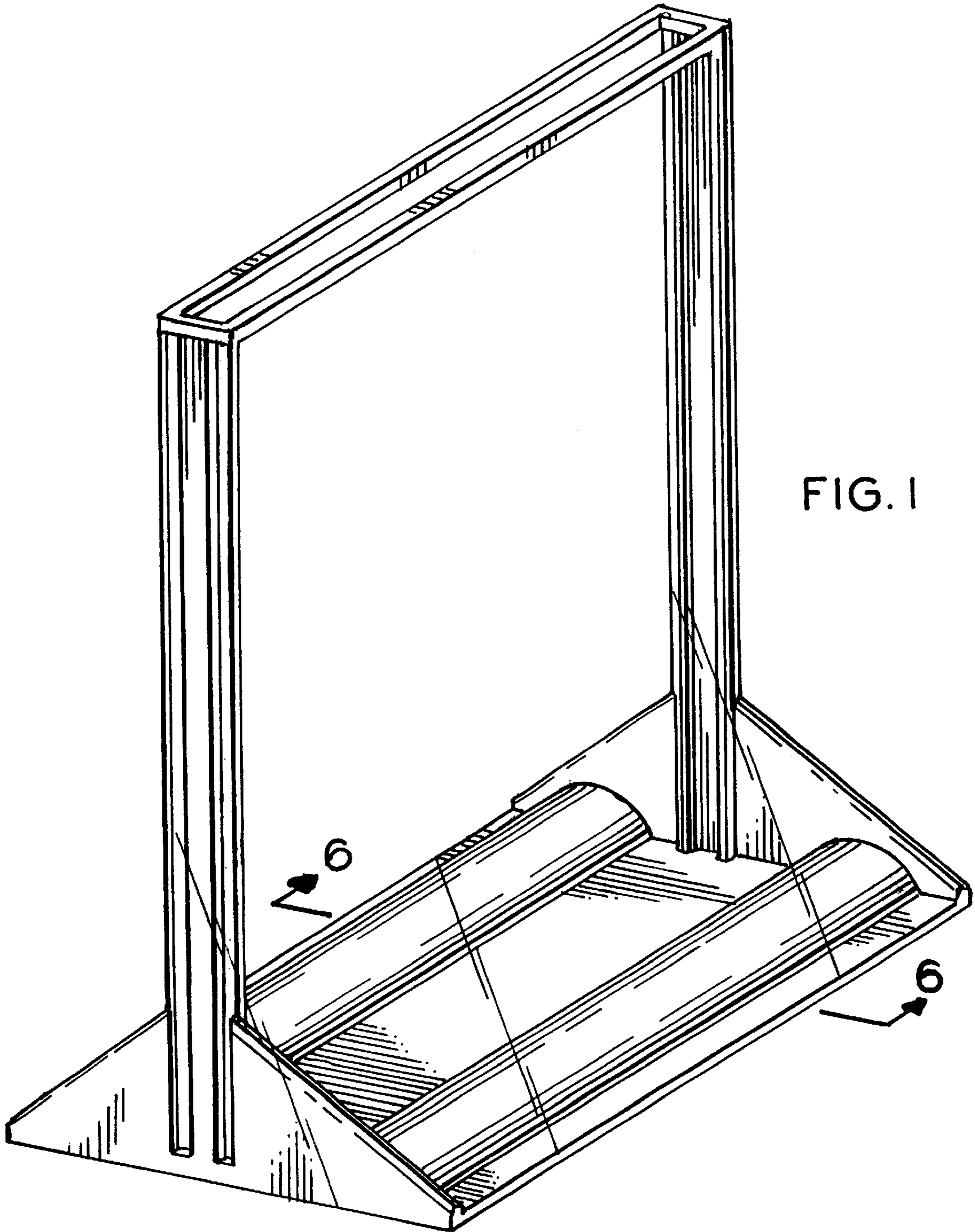

FIG. 1

FIG. 2

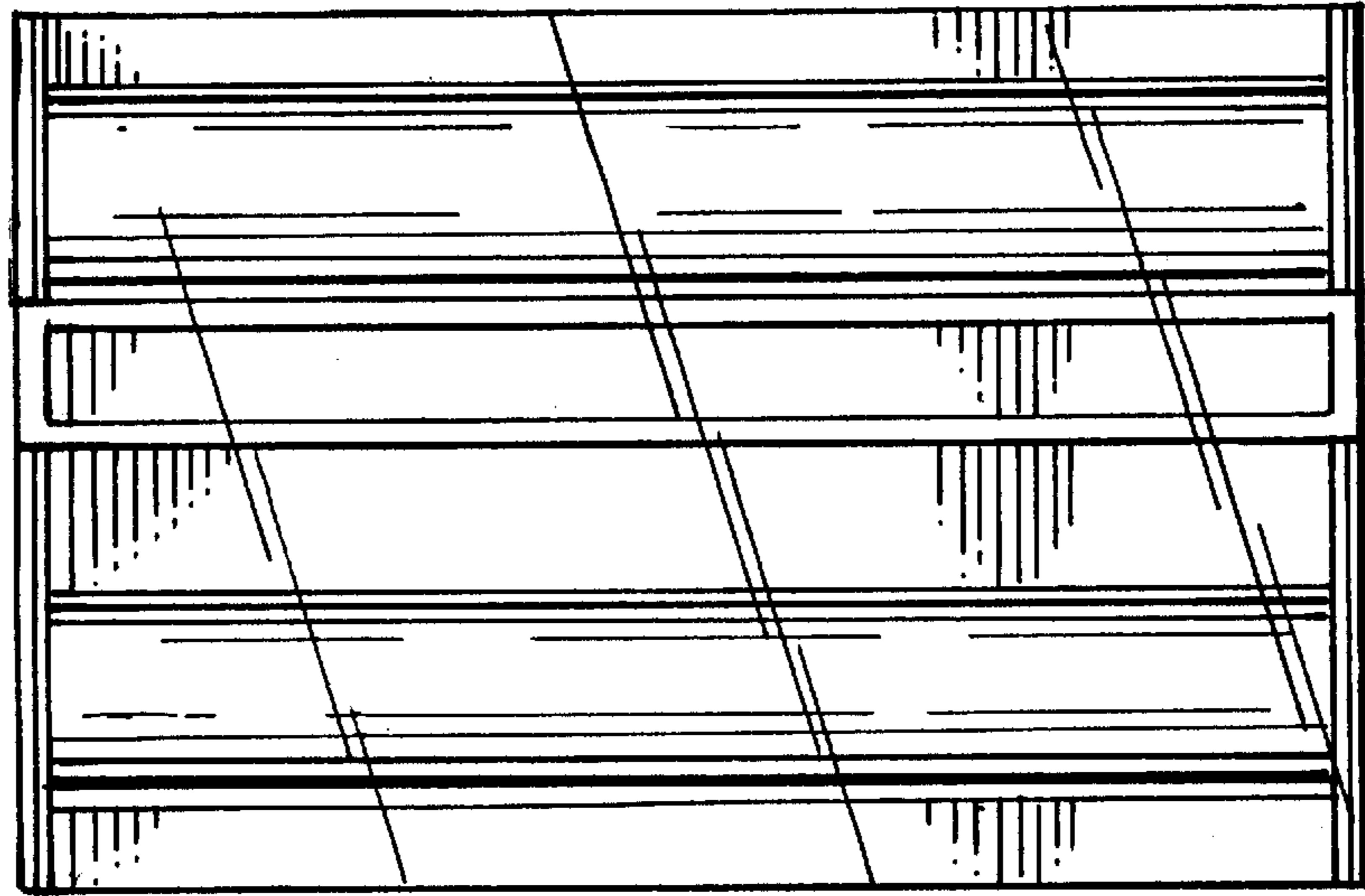
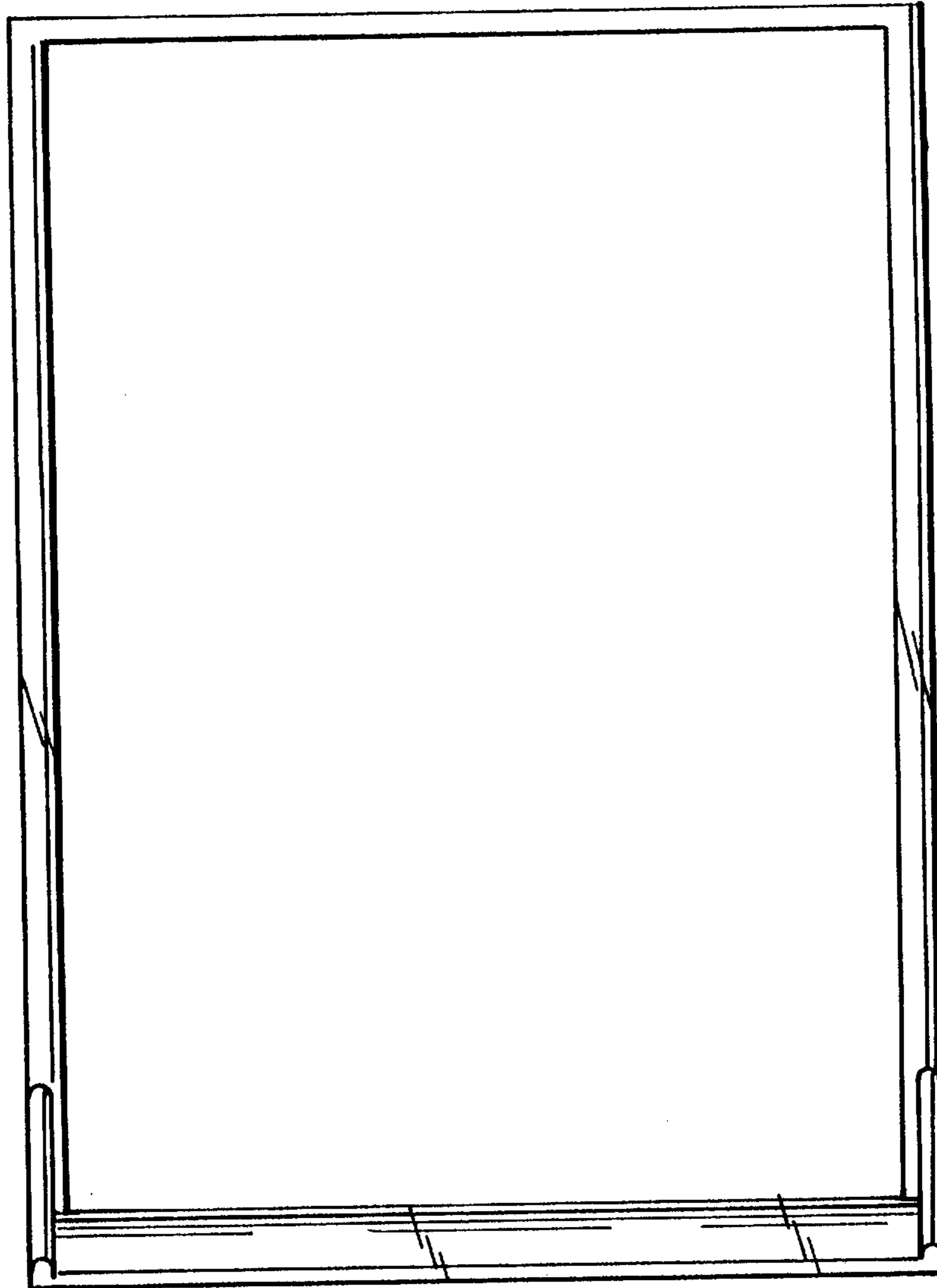

FIG. 3



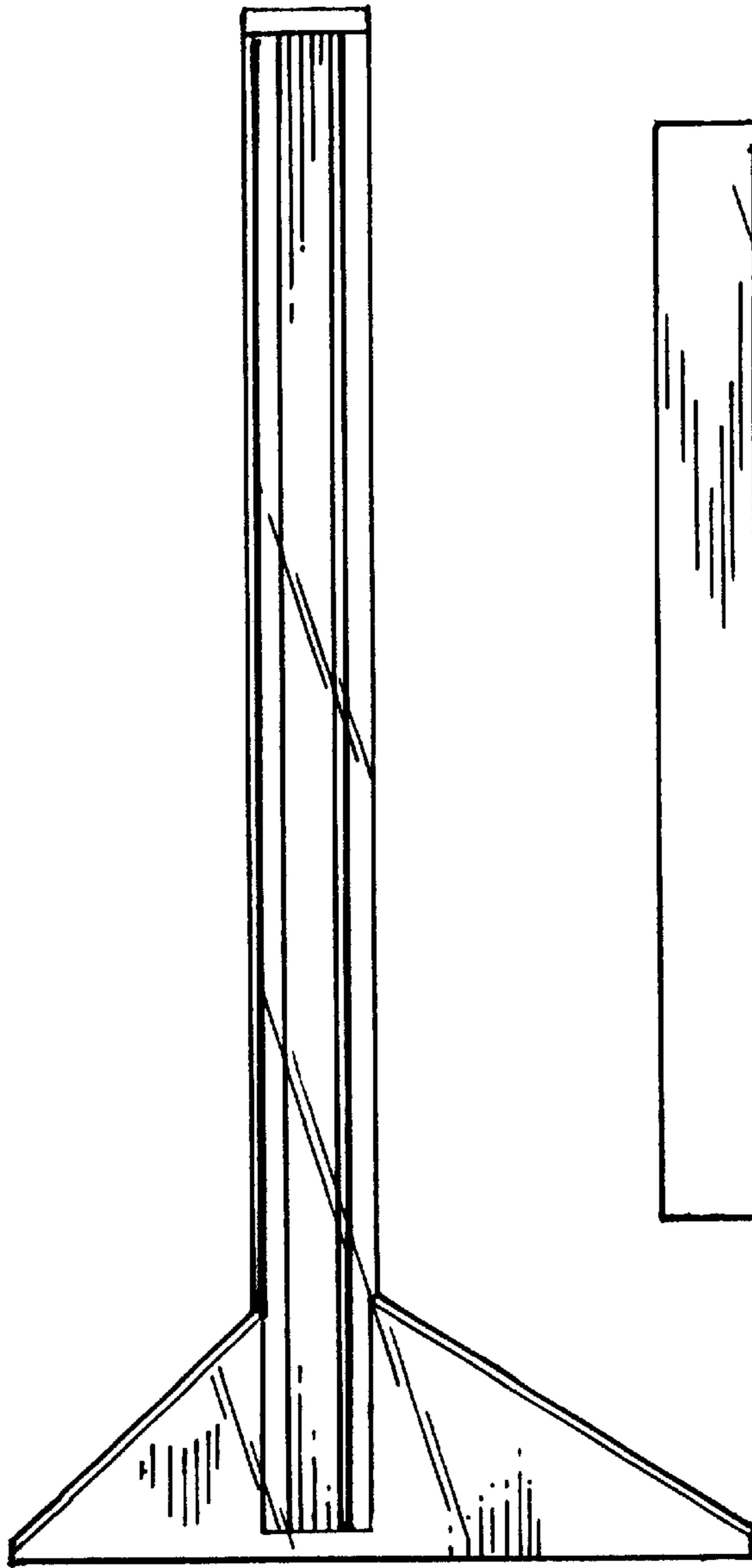

FIG. 4

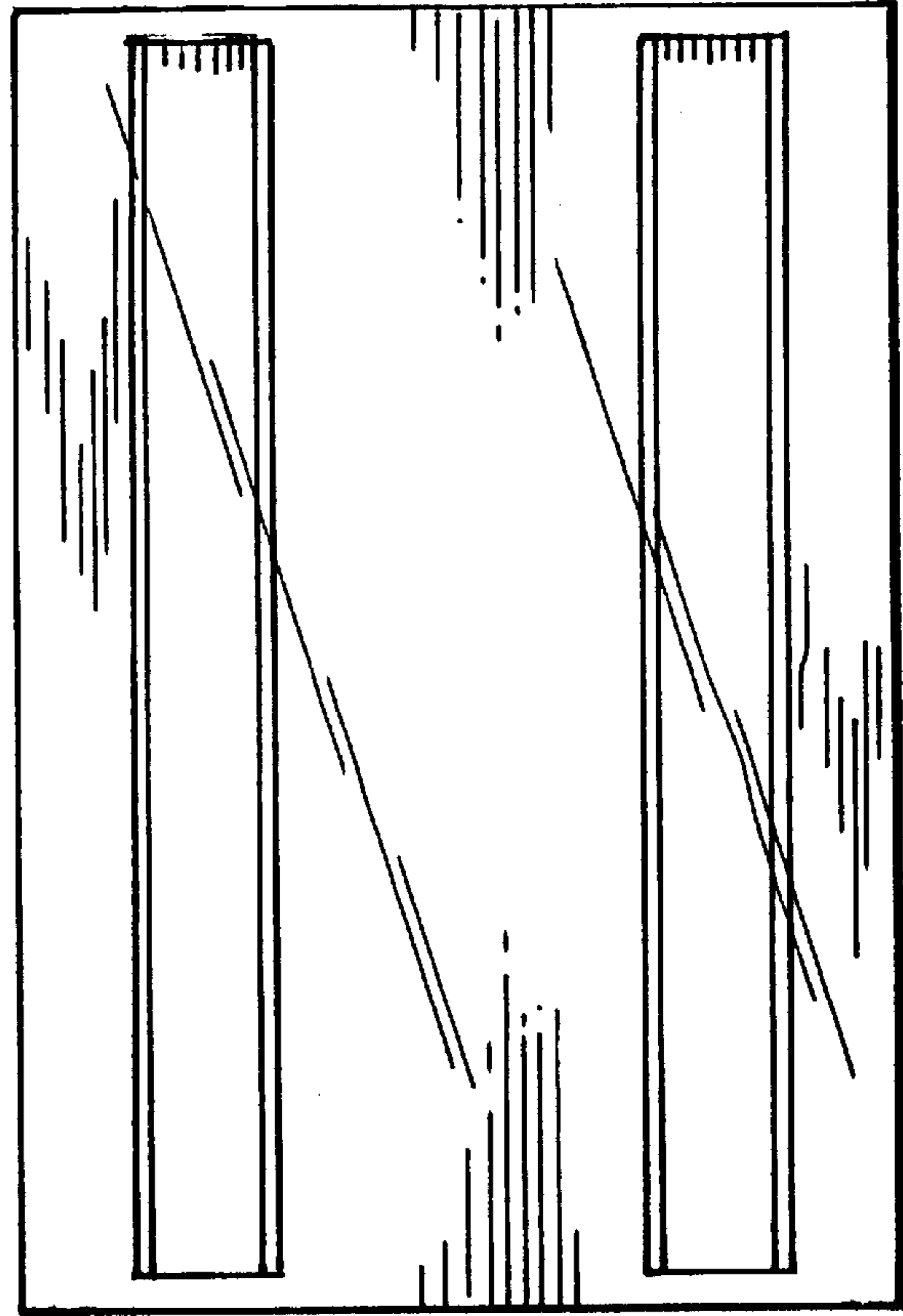

FIG. 5

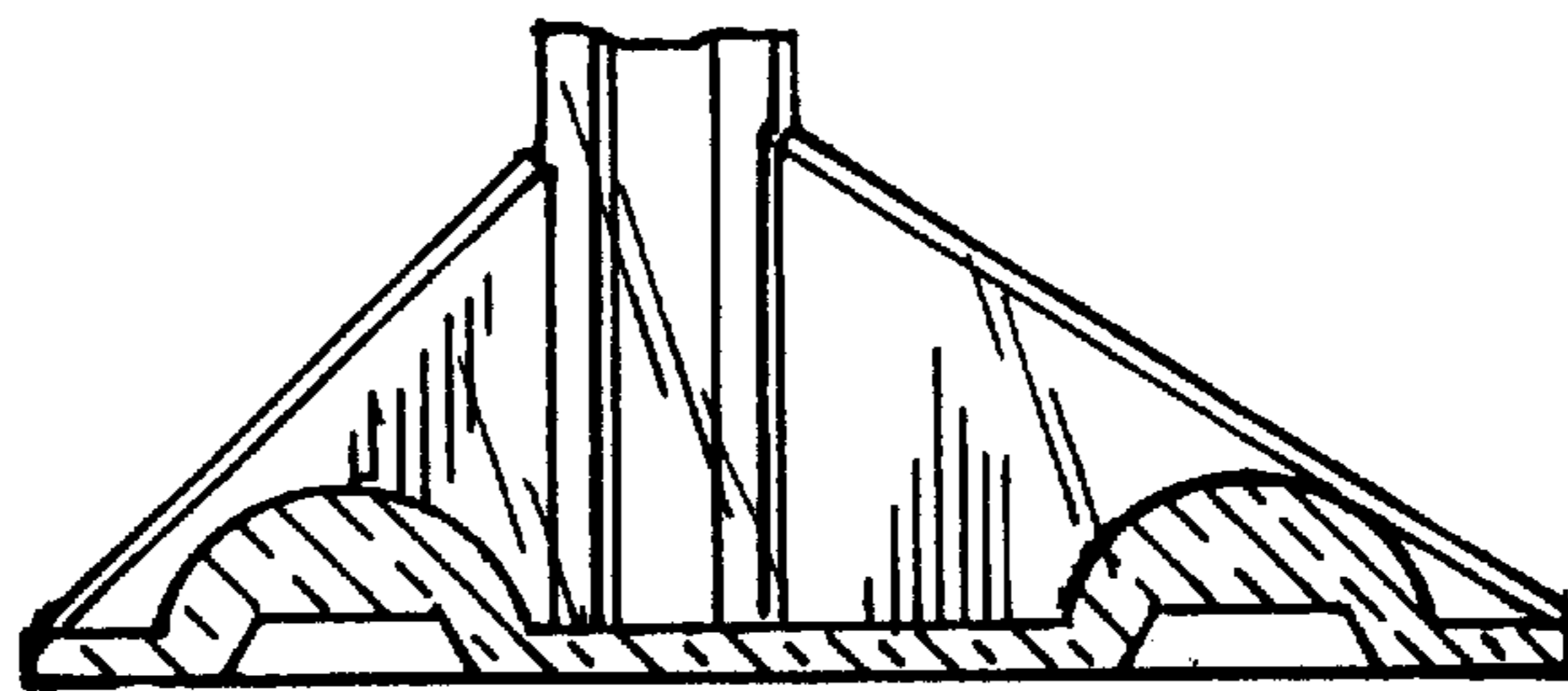

FIG. 6