



US00D445803S

(12) **United States Design Patent**
Ratto

(10) **Patent No.:** **US D445,803 S**

(45) **Date of Patent:** **** Jul. 31, 2001**

(54) **HEAT SINK FOR TWO-STROKE ENGINE**

5,311,847 * 5/1994 Boehning 123/90.38

(76) Inventor: **Richard J. Ratto**, 121 Landrum Cir.,
Folsom, CA (US) 95630

* cited by examiner

(**) Term: **14 Years**

Primary Examiner—Melody N. Brown
(74) *Attorney, Agent, or Firm*—Heisler & Associates

(21) Appl. No.: **29/110,547**

(57) **CLAIM**

(22) Filed: **Sep. 9, 1999**

The ornamental design for a heat sink for two-stroke engine,
as shown and described.

(51) **LOC (7) Cl.** **15-01**

DESCRIPTION

(52) **U.S. Cl.** **D15/5**

(58) **Field of Search** D15/5; D12/114;
123/54.4, 55.1, 197.3, 523, 90.38; 261/50.1

FIG. 1 is a perspective view of the heat sink for two-stroke engine;
FIG. 2 is a front elevation view of the invention;
FIG. 3 is a right side view of the invention, the left side view being a mirror image;
FIG. 4 is a top plan view of the invention;
FIG. 5 is a rear elevation view of the invention; and,
FIG. 6 is a bottom plan view of the invention.

(56) **References Cited**

U.S. PATENT DOCUMENTS

- Re. 35,179 * 3/1996 Klus D15/5
- D. 370,682 * 6/1996 Jennings et al. D15/5
- D. 432,546 * 10/2000 Savage et al. D15/5
- D. 436,112 * 1/2001 Savage et al. D15/5

1 Claim, 2 Drawing Sheets

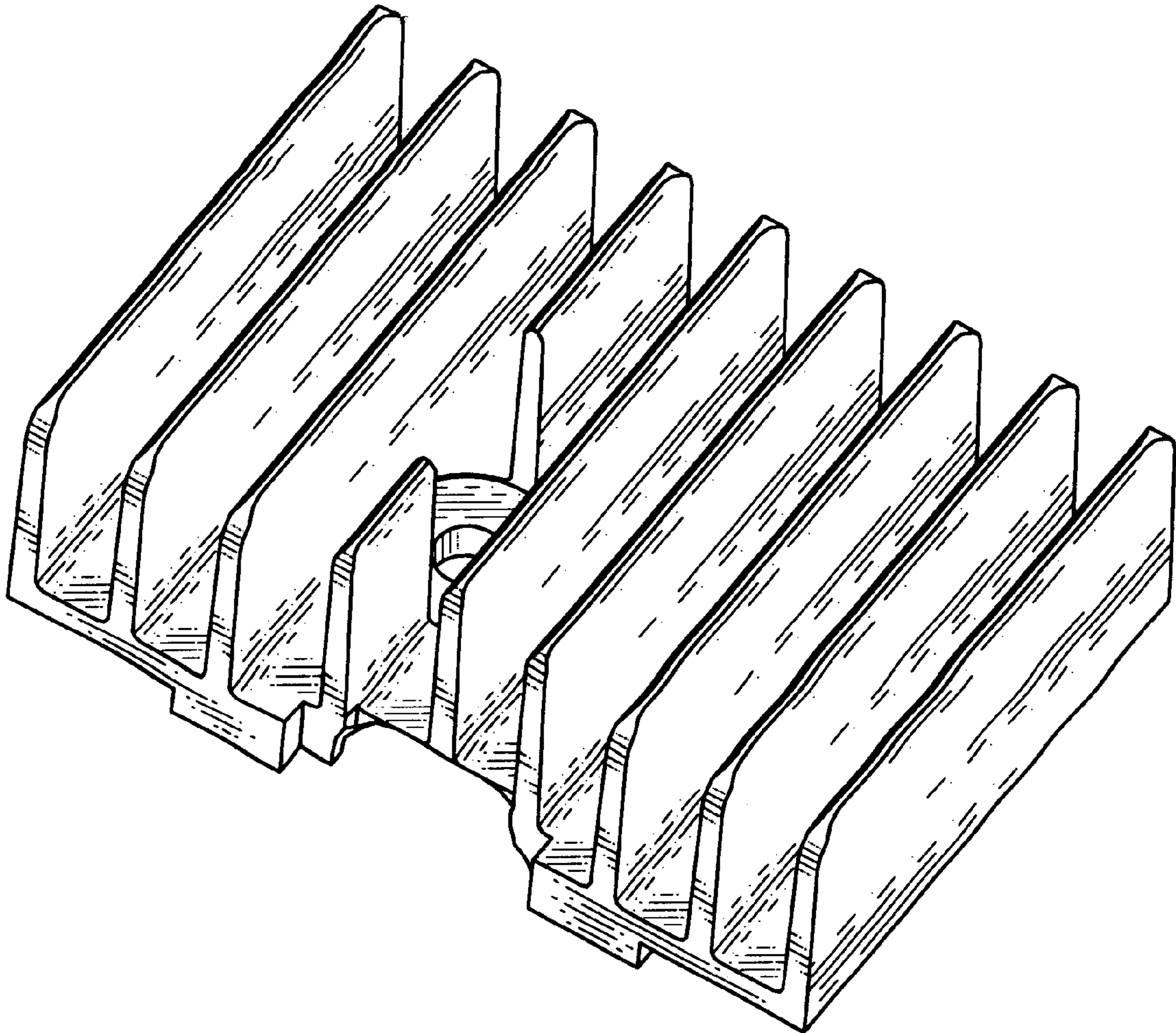

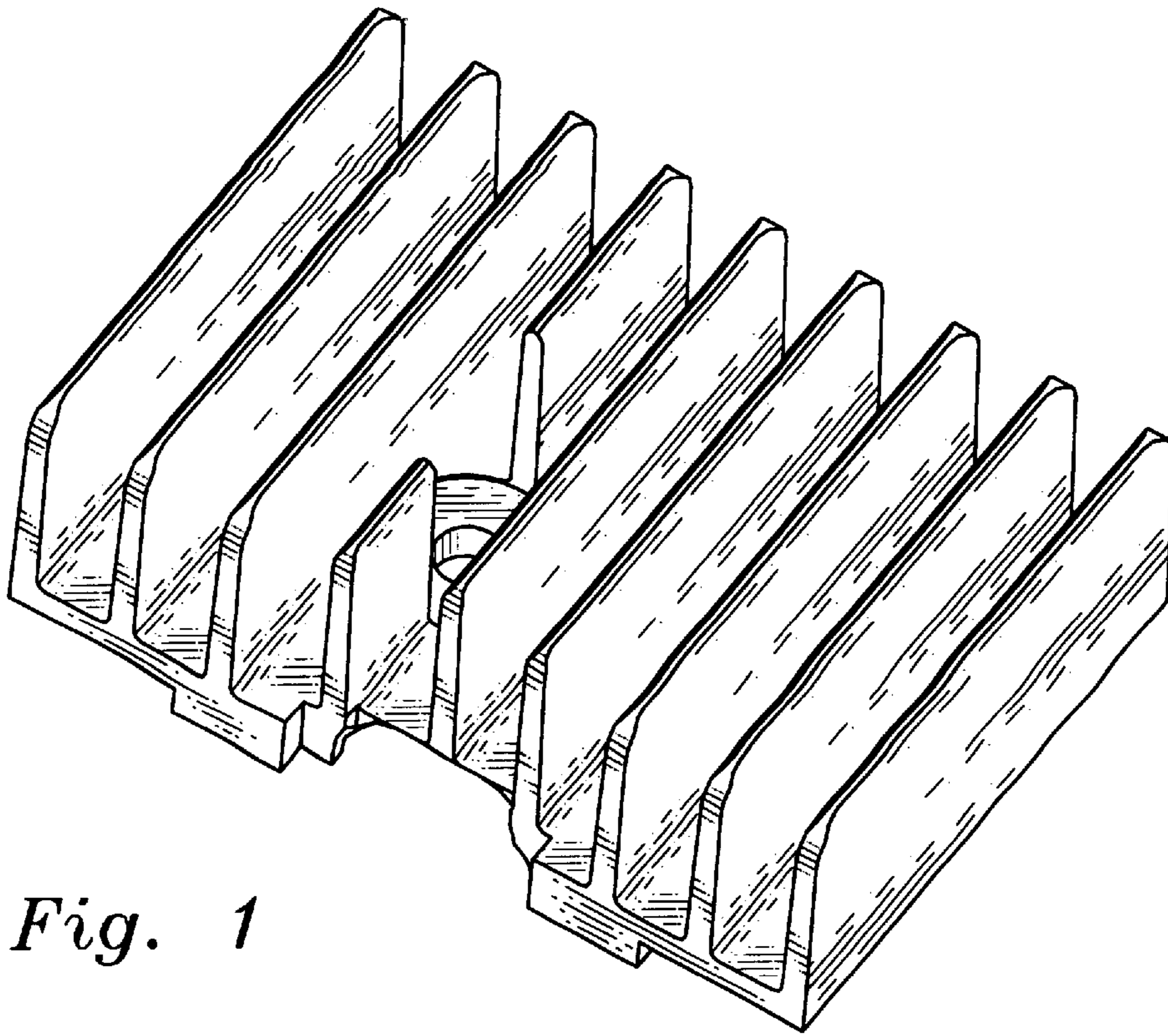

Fig. 1

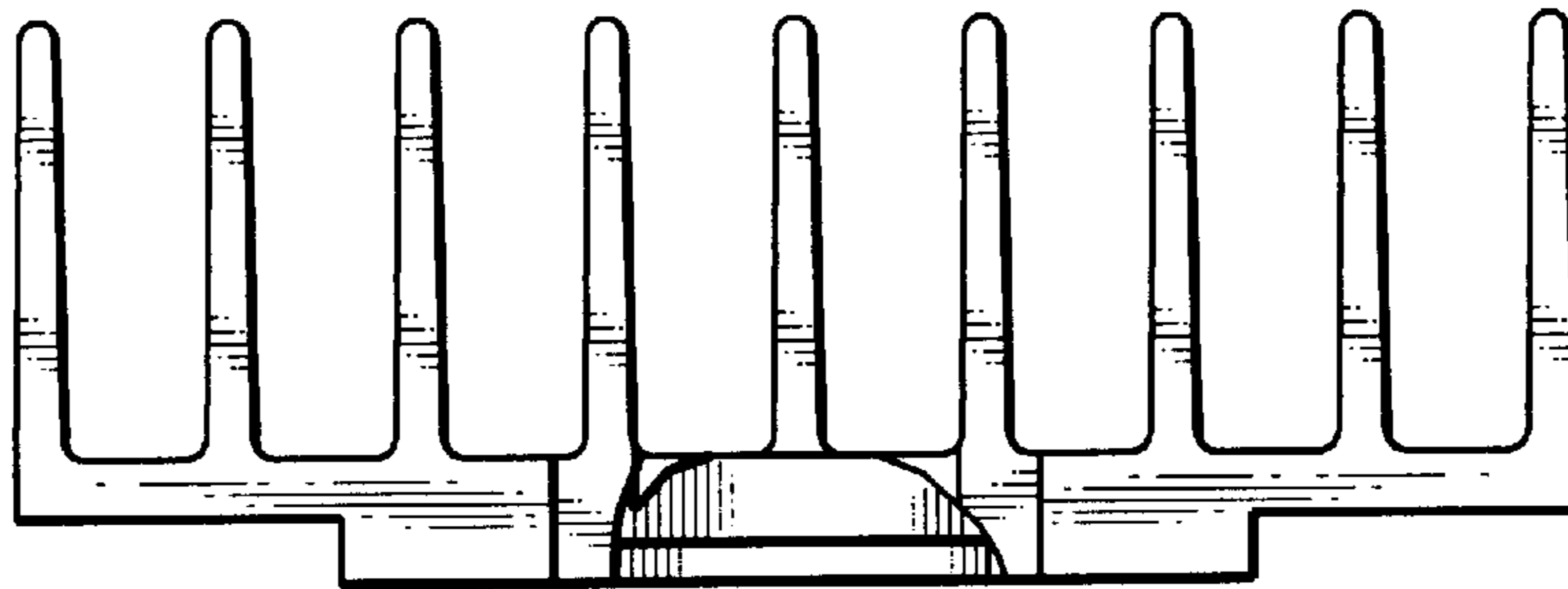

Fig. 2

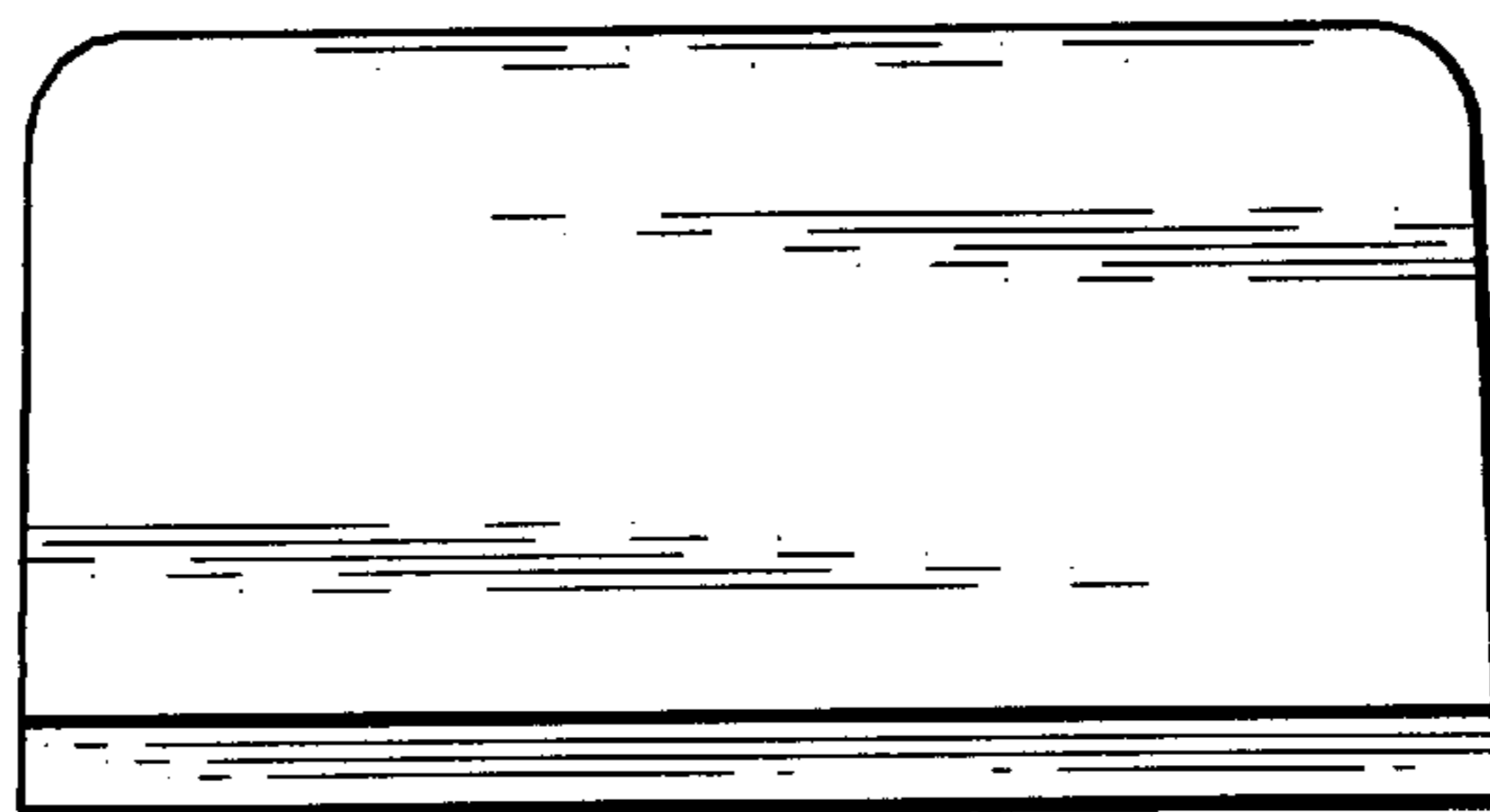

Fig. 3

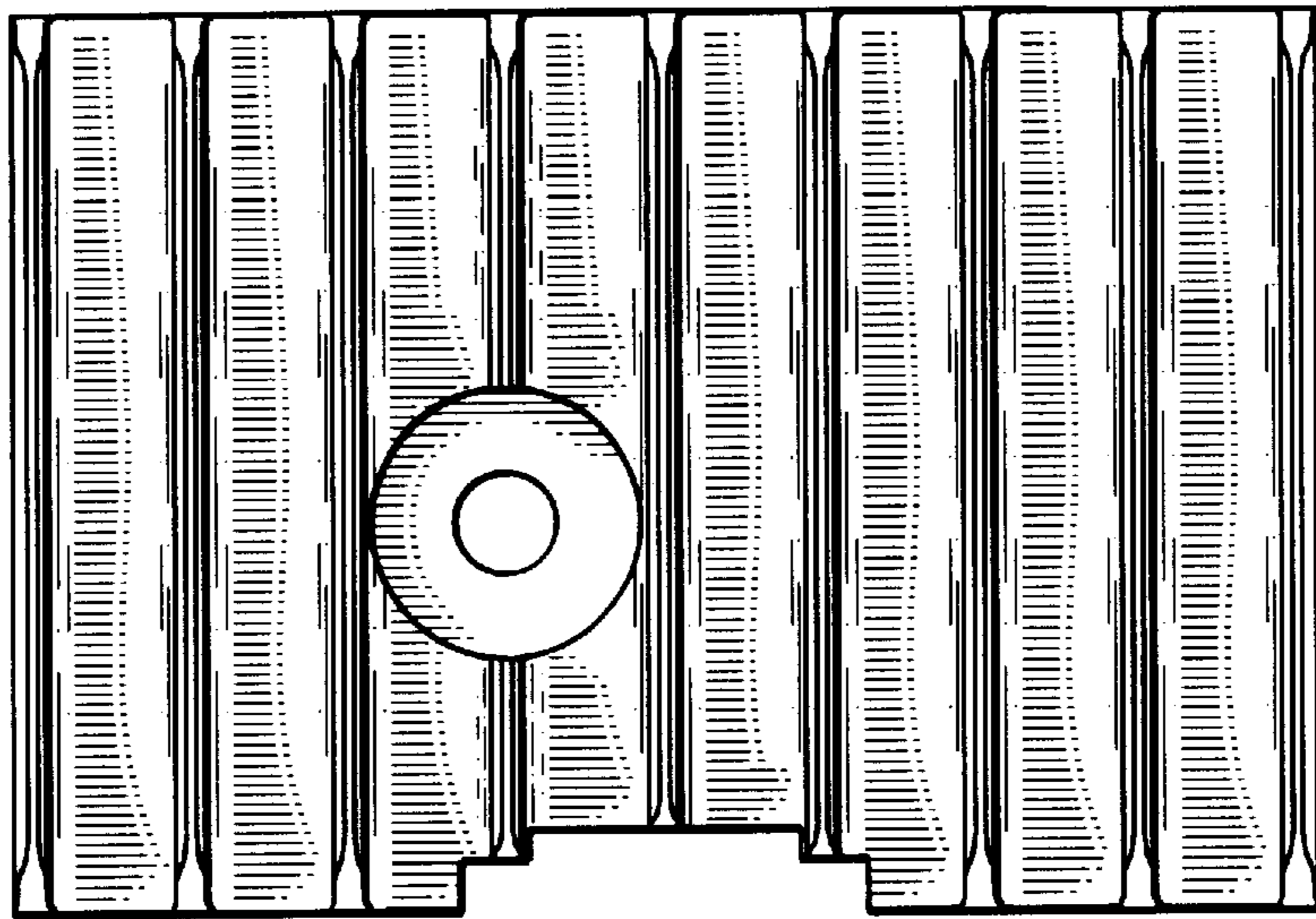

Fig. 4

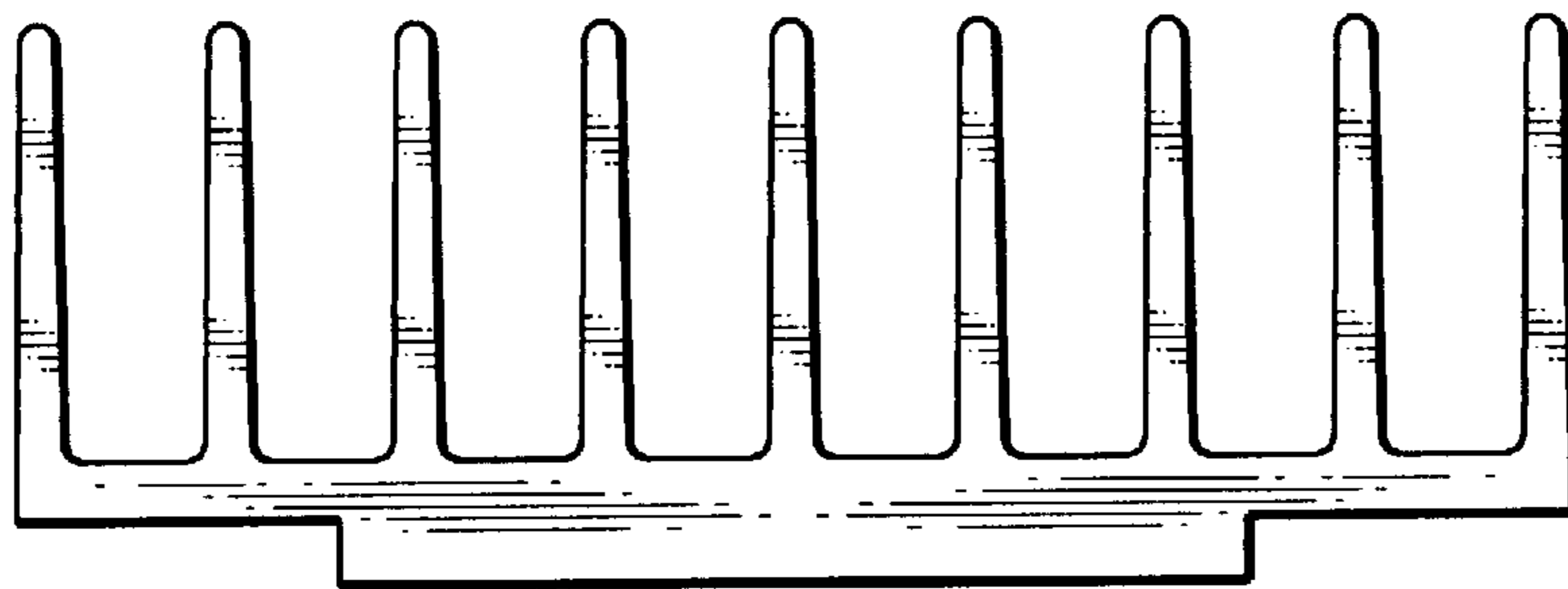

Fig. 5

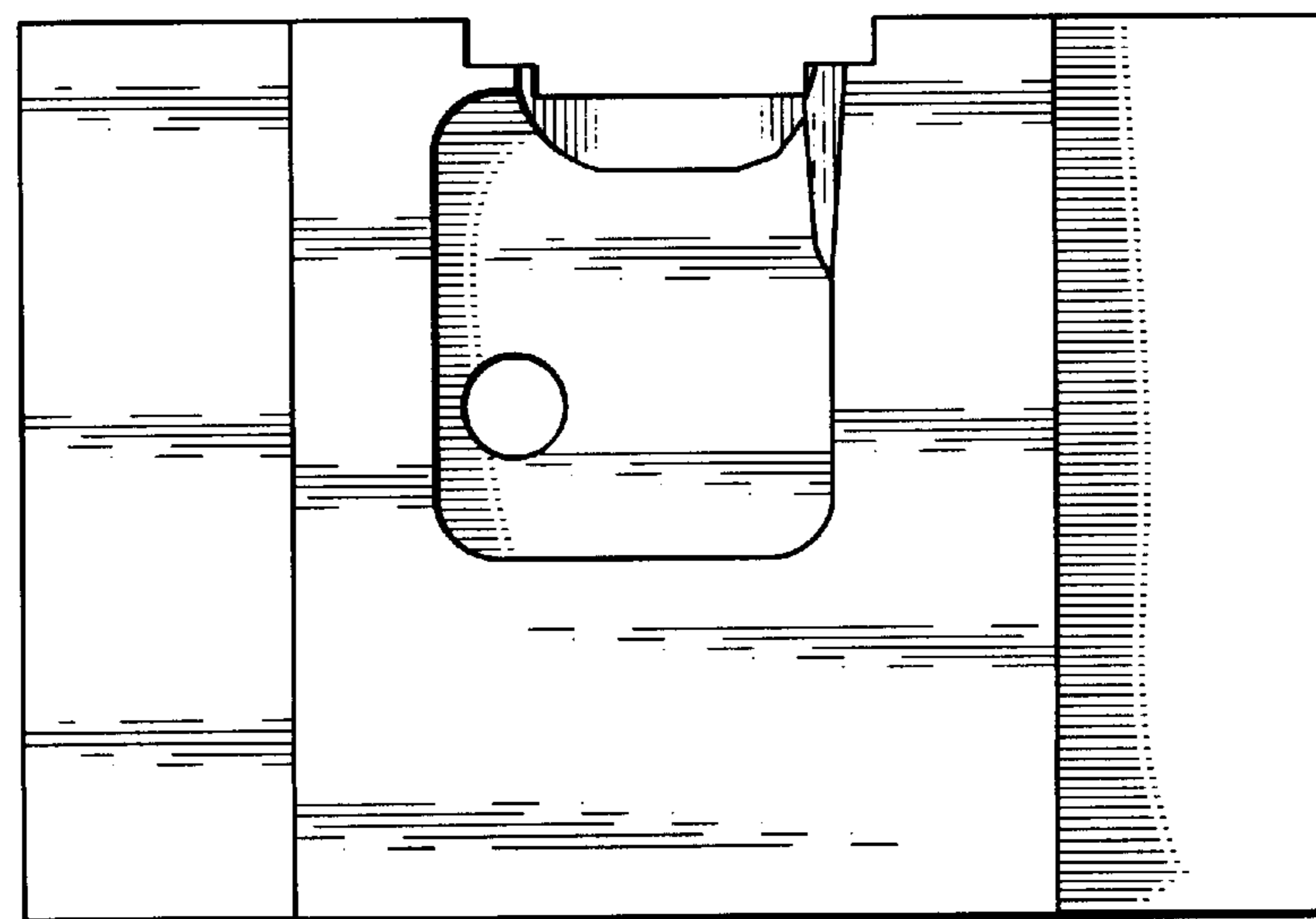

Fig. 6