



US00D445711S

(12) **United States Design Patent**
Lyons

(10) **Patent No.:** **US D445,711 S**

(45) **Date of Patent:** **** Jul. 31, 2001**

(54) **COMBINED SIREN AND LIGHTHEAD ASSEMBLY FOR A VEHICLE BUMPER**

(75) **Inventor:** **Harold W. Lyons**, Edgewater, FL (US)

(73) **Assignee:** **Whelen Engineering Company, Inc.**,
Chester, CT (US)

(**) **Term:** **14 Years**

(21) **Appl. No.:** **29/134,280**

(22) **Filed:** **Dec. 15, 2000**

(51) **LOC (7) Cl.** **10-05**

(52) **U.S. Cl.** **D10/120**

(58) **Field of Search** D26/28-36; 362/80,
362/81, 82, 83, 309, 326, 329-340, 418,
419, 429; D10/104, 120, 116

(56) **References Cited**

U.S. PATENT DOCUMENTS

- D. 382,221 * 8/1997 Chen D10/120
- D. 417,740 * 12/1999 Iacovelli et al. D26/28

* cited by examiner

Primary Examiner—Marcus A. Jackson

(74) *Attorney, Agent, or Firm*—Alix, Yale & Ristas, LLP

(57) **CLAIM**

The ornamental design for a combined siren and lighthouse assembly for a vehicle bumper, as shown and described.

DESCRIPTION

FIG. 1 is a frontal perspective view of a combined siren and lighthouse assembly for a vehicle bumper for the vehicle driver side thereof;

FIG. 2 is a front elevational view of a combined siren and lighthouse assembly of FIG. 1;

FIG. 3 is a right side view of a combined siren and lighthouse assembly of FIG. 1;

FIG. 4 is a left side view of a combined siren and lighthouse assembly of FIG. 1;

FIG. 5 is a top plan view of a combined siren and lighthouse assembly of FIG. 1;

FIG. 6 is a bottom plan view of a combined siren and lighthouse assembly of FIG. 1;

FIG. 7 is a frontal perspective view of a combined siren and lighthouse assembly for a vehicle bumper for the passenger side thereof;

FIG. 8 is a front elevational view of a combined siren and lighthouse assembly of FIG. 7;

FIG. 9 is a right side view of a combined siren and lighthouse assembly of FIG. 7;

FIG. 10 is a left side view of a combined siren and lighthouse assembly of FIG. 7;

FIG. 11 is a top plan view of a combined siren and lighthouse assembly of FIG. 7; and,

FIG. 12 is a bottom plan view of a combined siren and lighthouse assembly of FIG. 7.

The rear views of a combined siren and lighthouse assembly for the vehicle driver side and the passenger form no part of the claimed design.

The portions shown in broken lines form no part of the claim design.

1 Claim, 12 Drawing Sheets

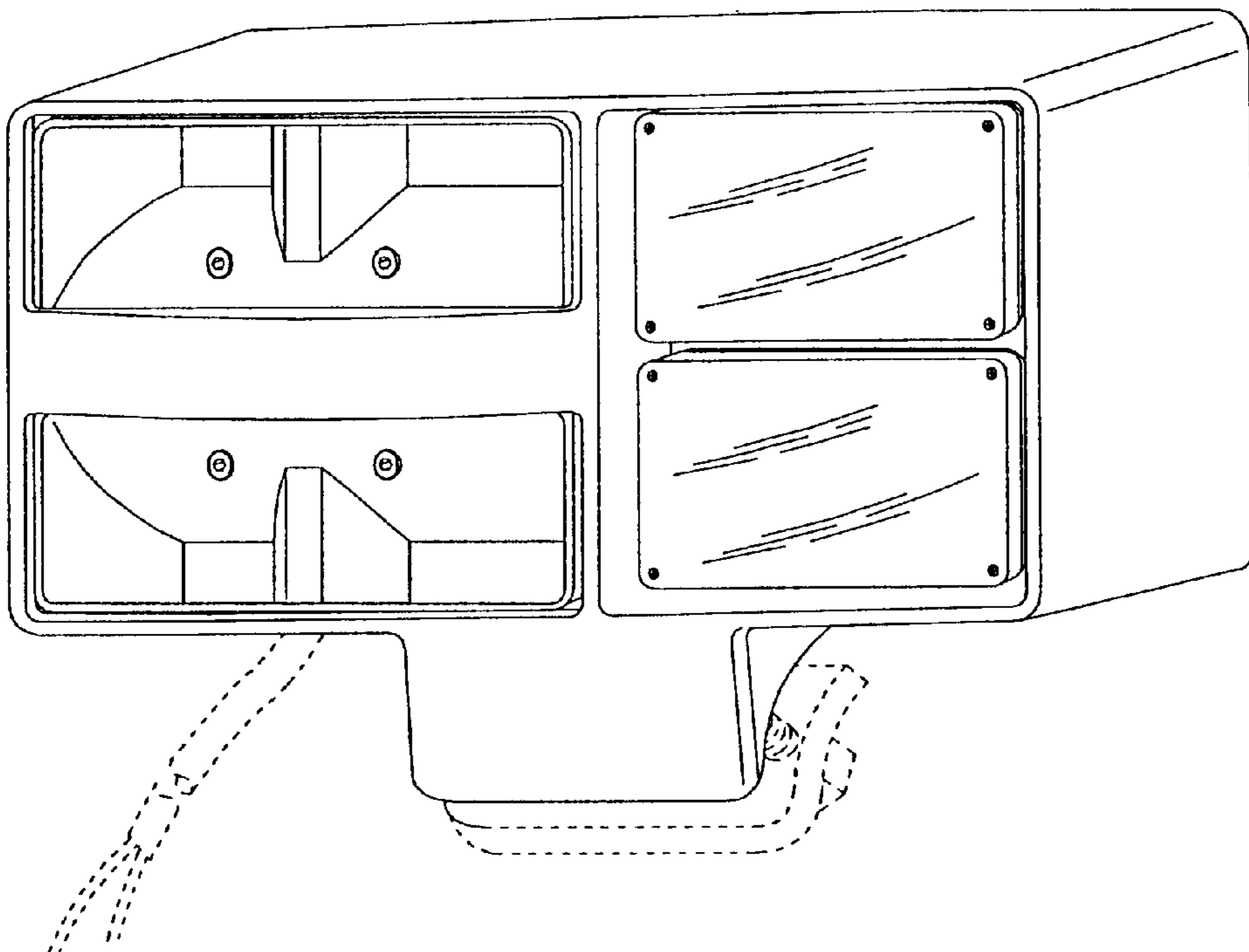

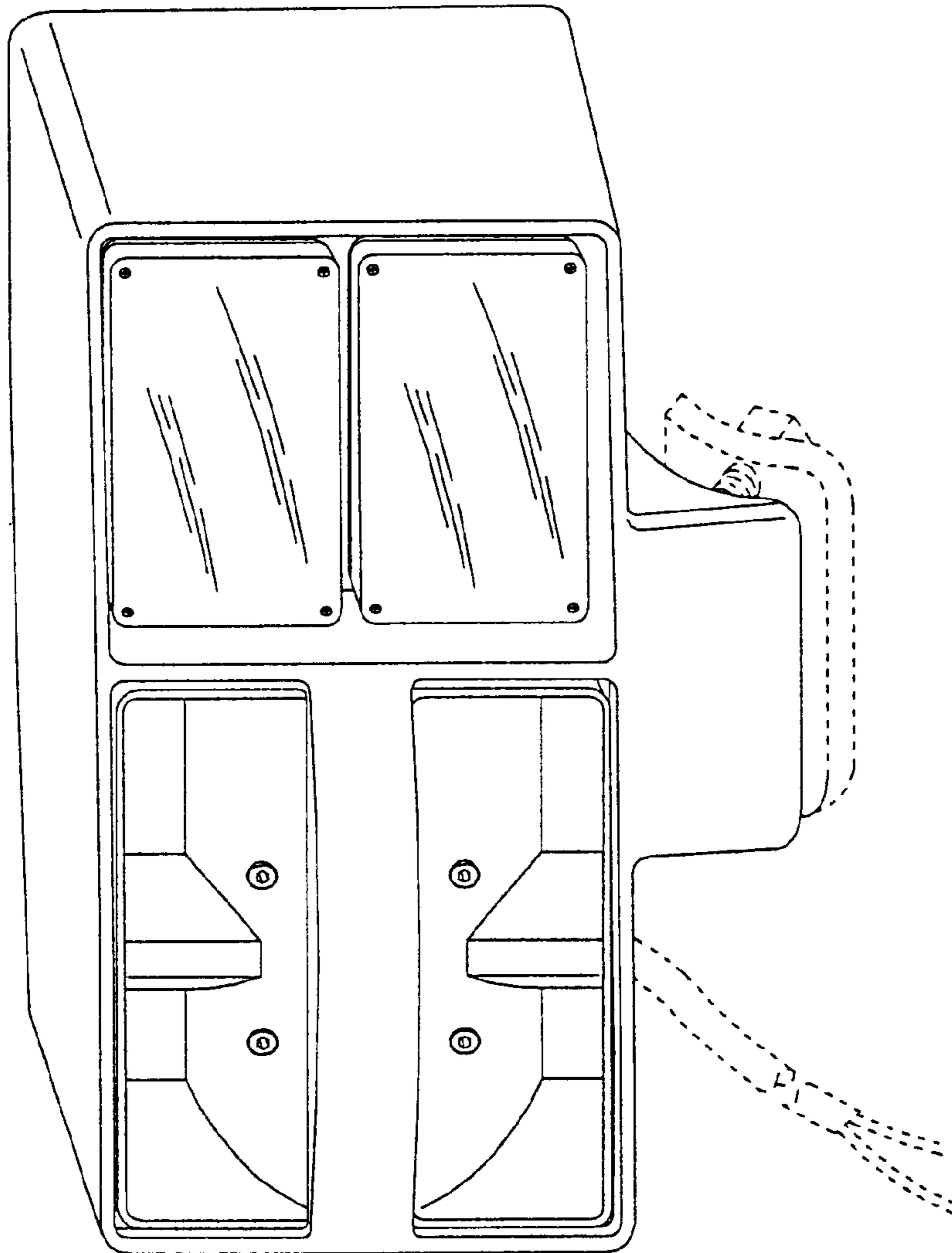

FIGURE 1

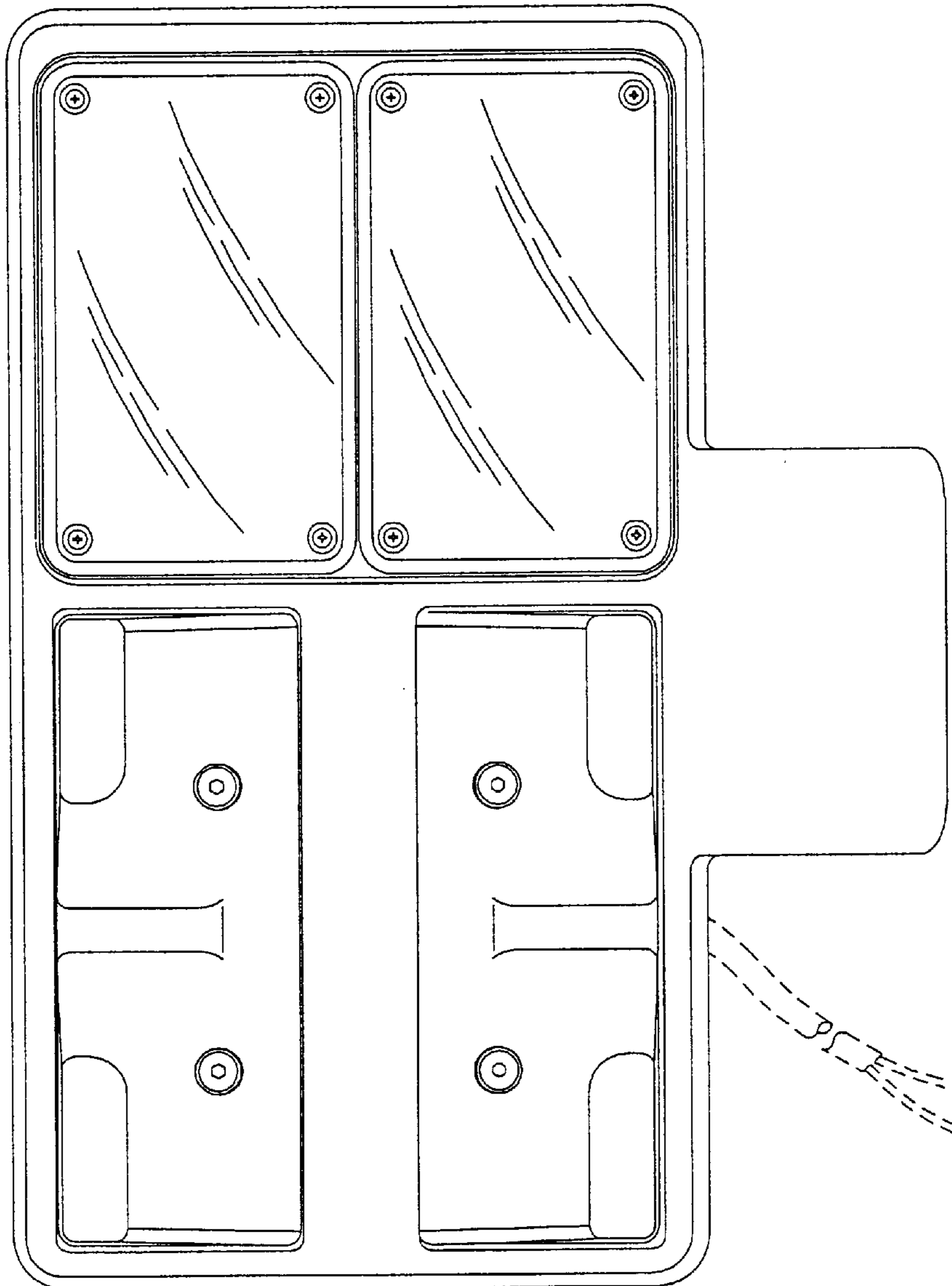

FIGURE 2

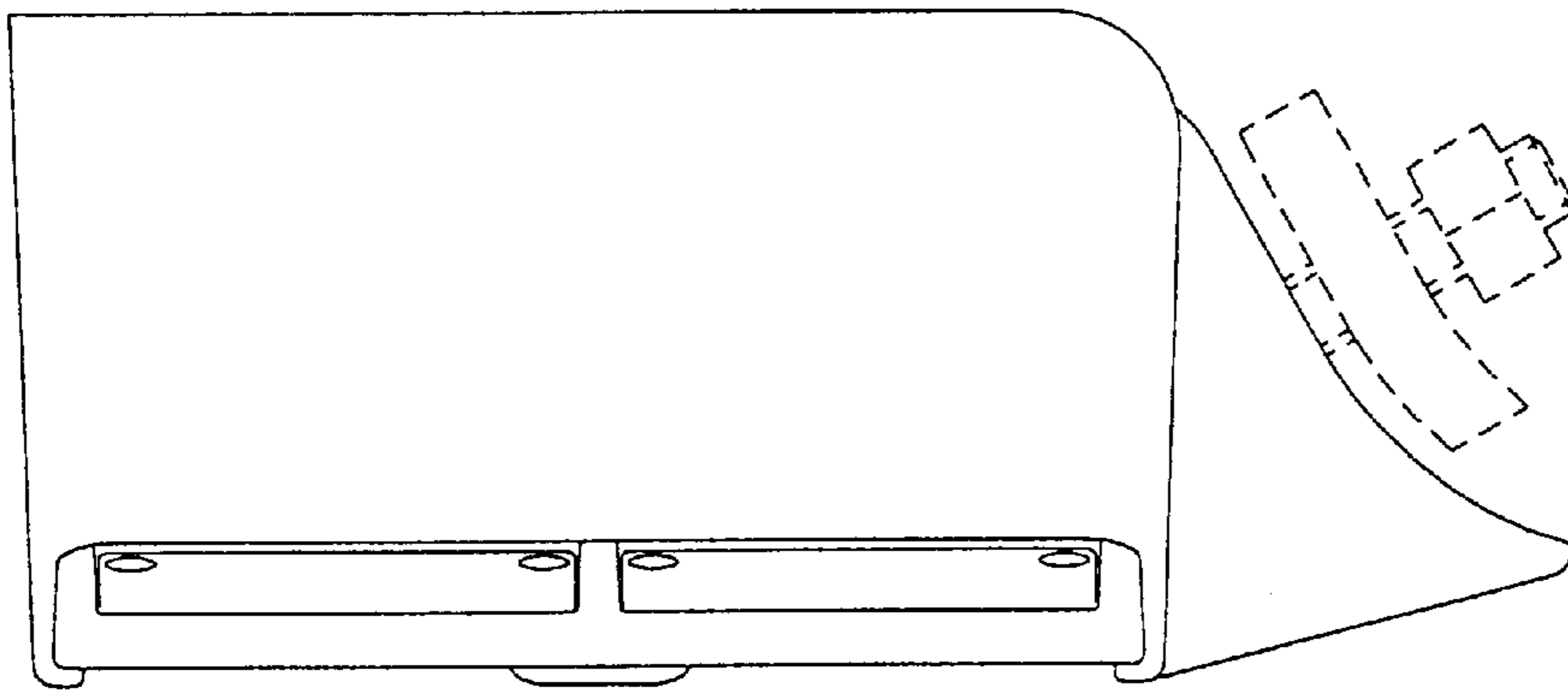

FIGURE 3

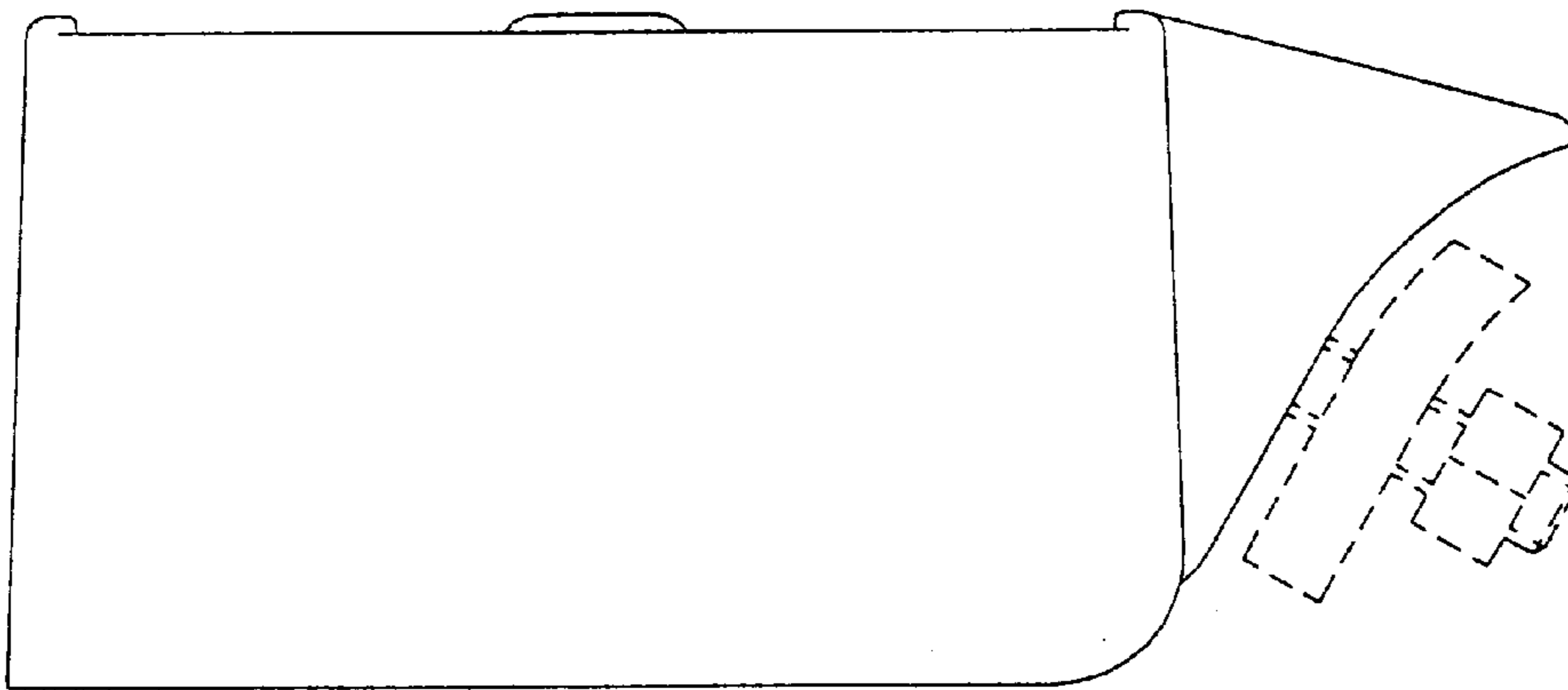

FIGURE 4

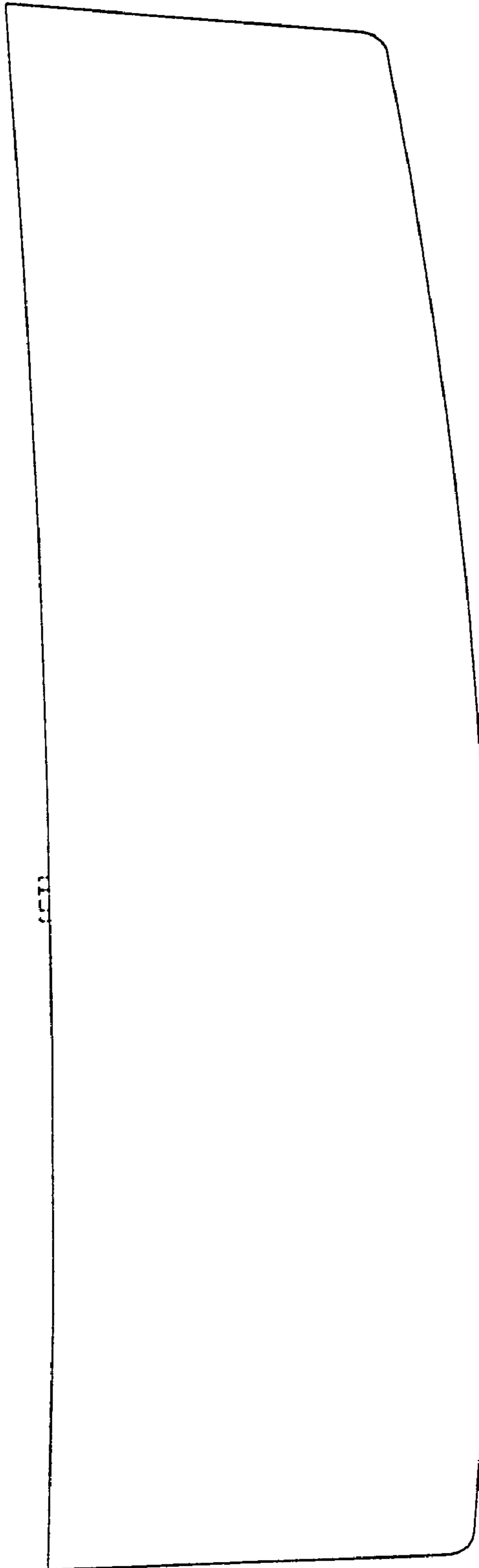

FIGURE 5

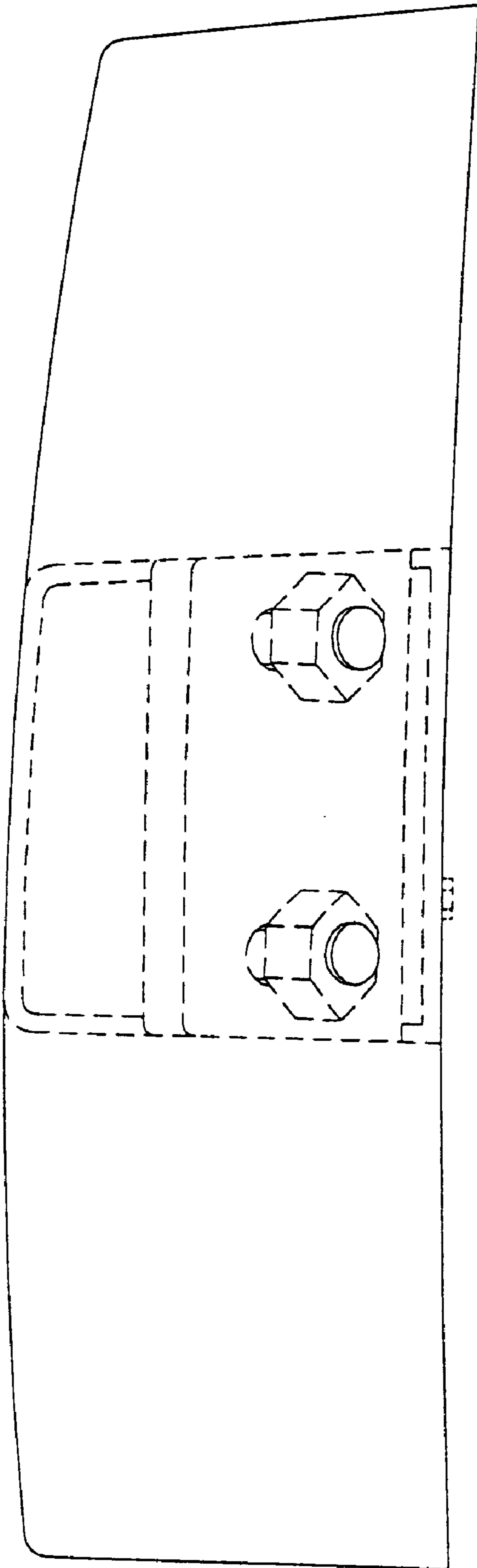

FIGURE 6

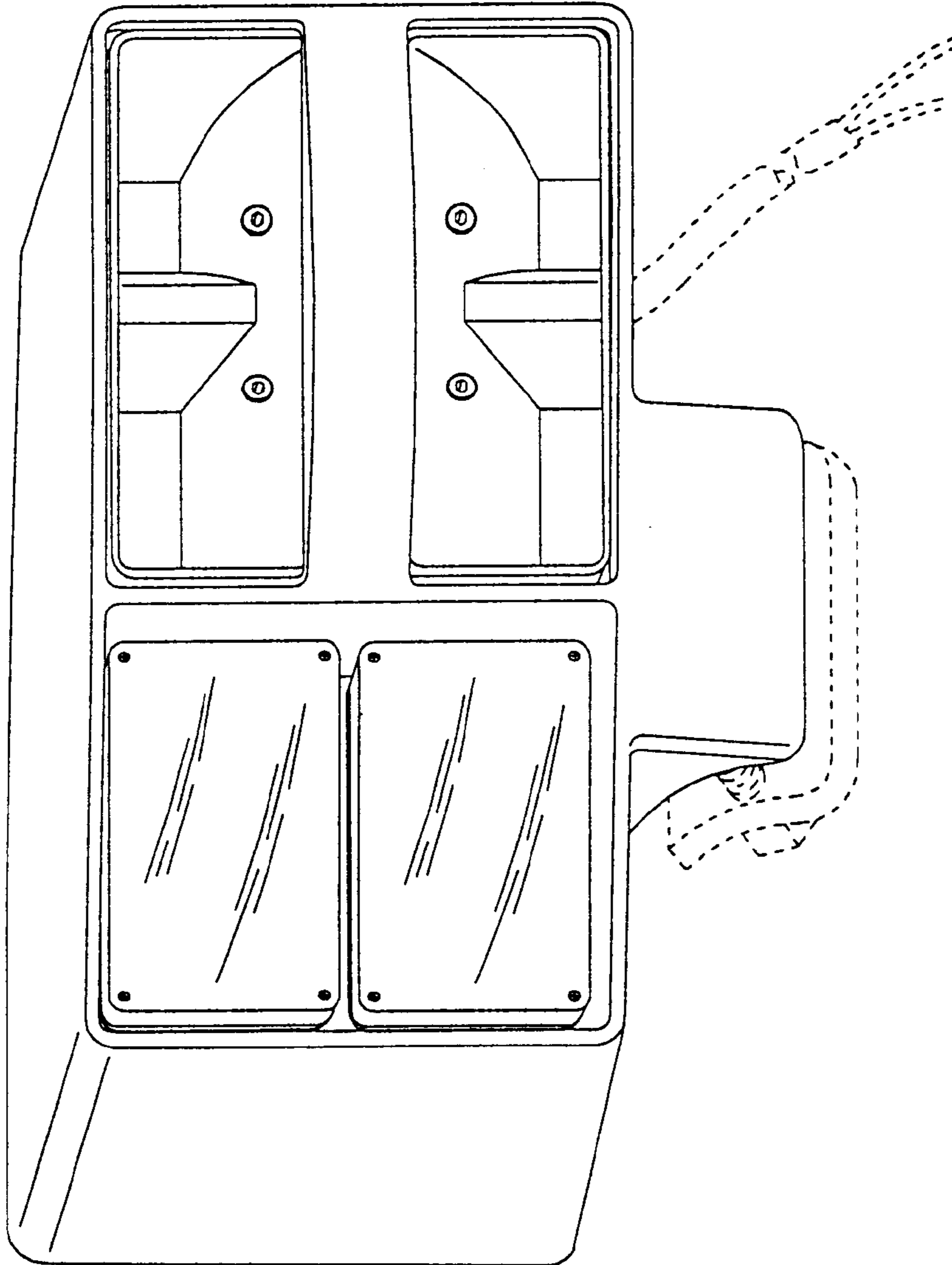

FIGURE 7

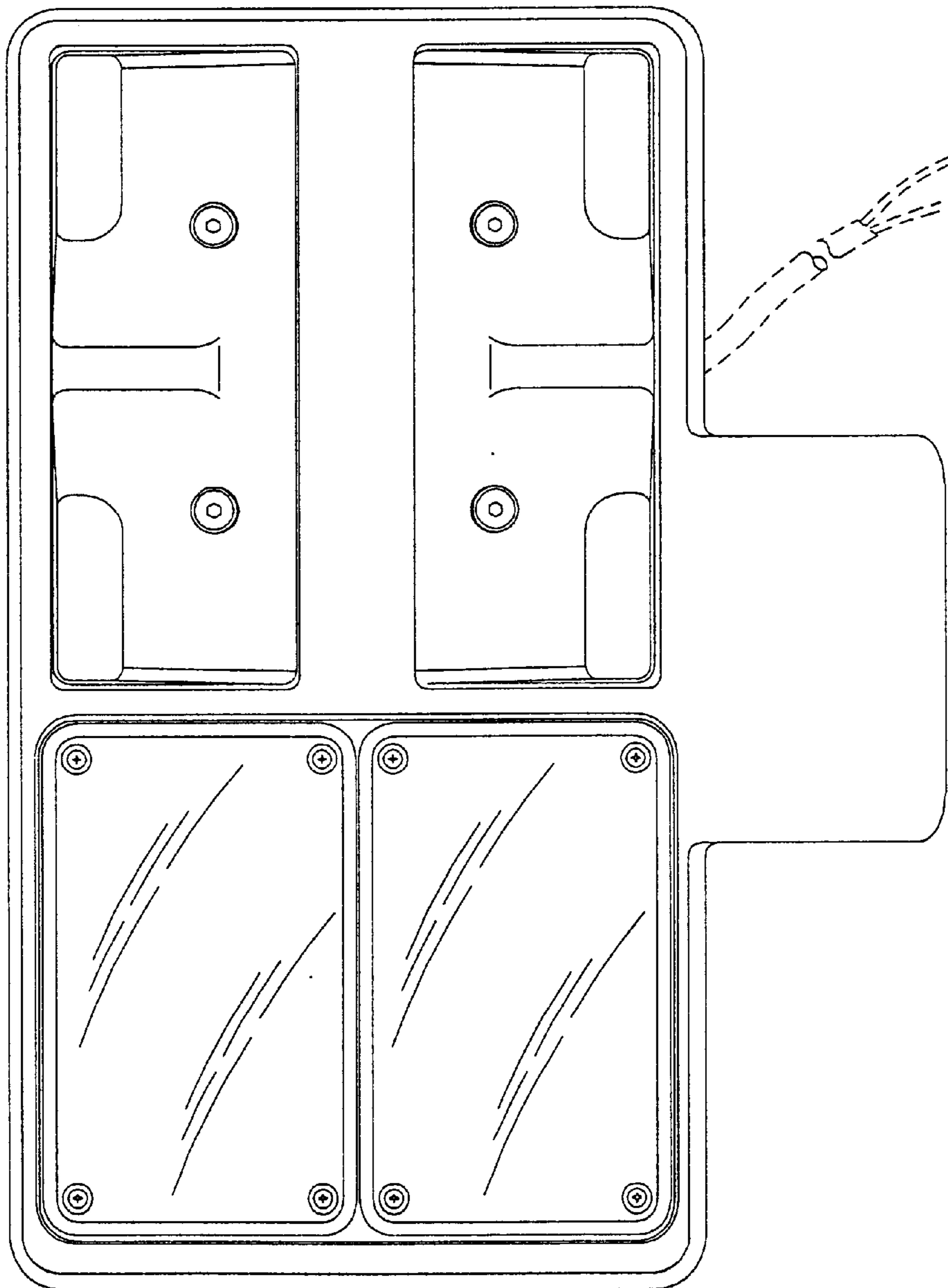

FIGURE 8

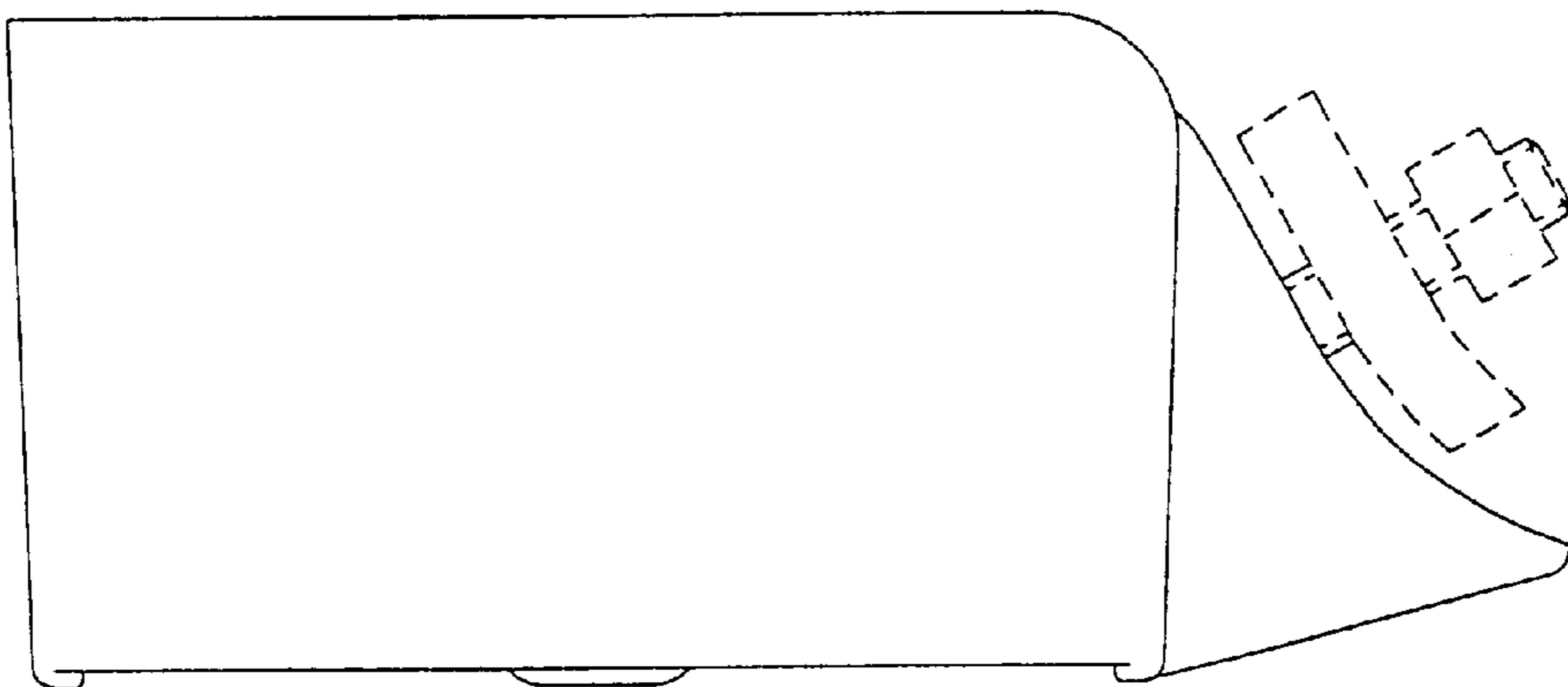

FIGURE 9

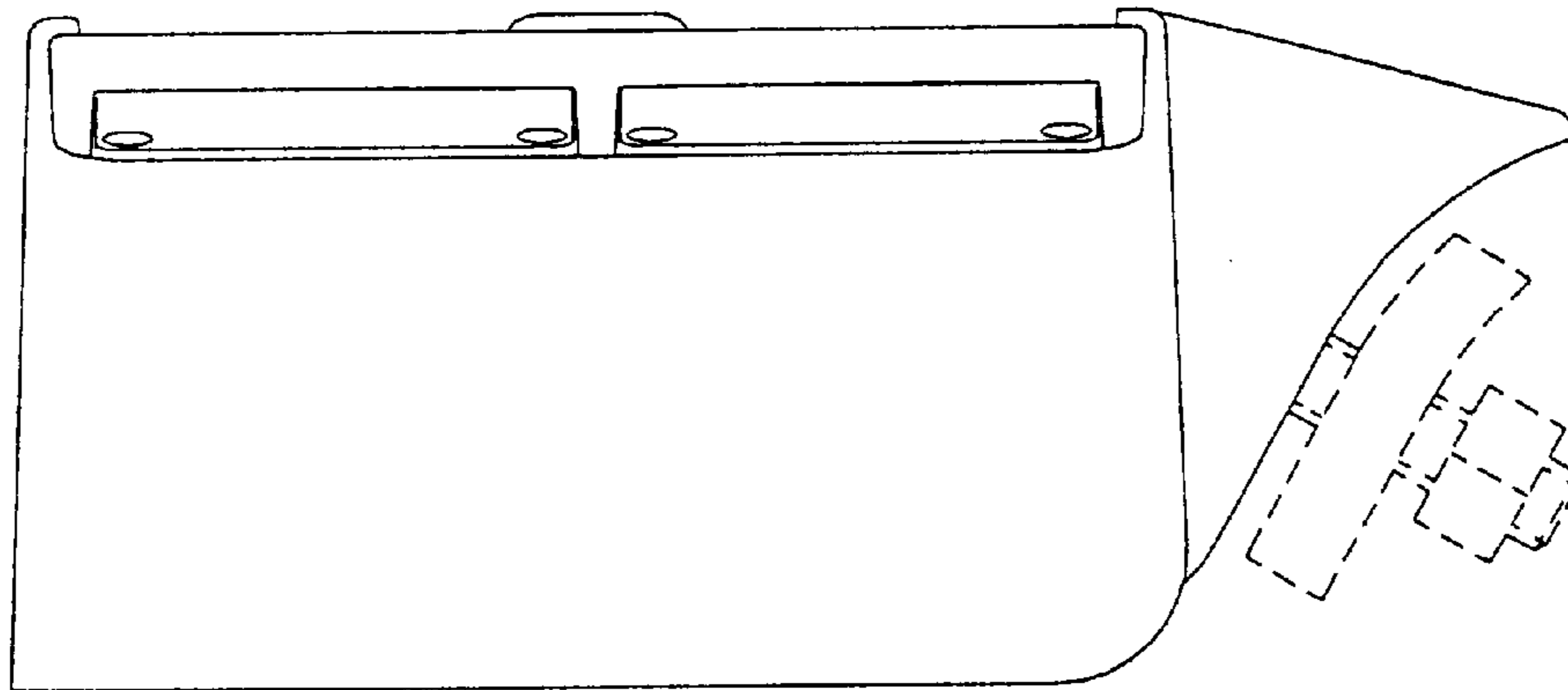

FIGURE 10

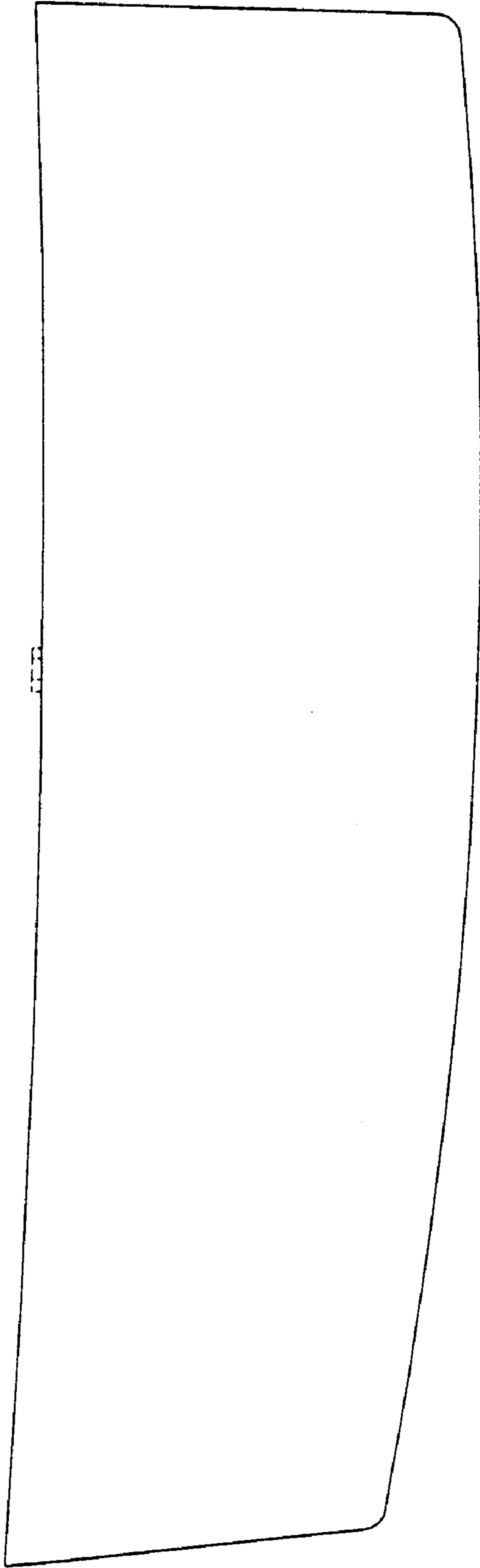

FIGURE 11

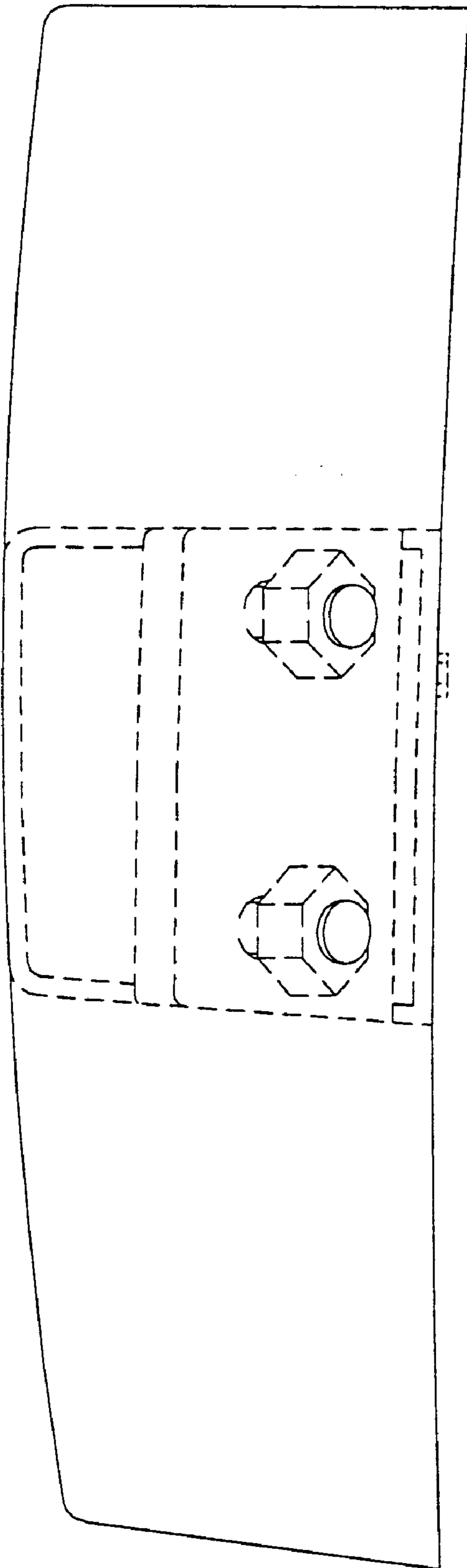

FIGURE 12