



US00D445520S

(12) **United States Design Patent**
Kaufman, Jr.

(10) **Patent No.:** **US D445,520 S**

(45) **Date of Patent:** **** Jul. 24, 2001**

(54) **RAILROAD FLASHLIGHT**

5,893,629	4/1999	Gubernick	362/186
5,980,063	11/1999	Ford et al.	362/186
6,086,218	7/2000	Robertson	362/157

(76) Inventor: **Tom C. Kaufman, Jr.**, P.O. Box 1404,
Winslow, AZ (US) 86047

(**) Term: **14 Years**

* cited by examiner

Primary Examiner—Marcus A. Jackson
(74) *Attorney, Agent, or Firm*—The Halvorson Law Firm

(21) Appl. No.: **29/132,170**

(22) Filed: **Nov. 4, 2000**

(57) **CLAIM**

(51) **LOC (7) Cl.** **26-02**

(52) **U.S. Cl.** **D26/41; D26/49**

(58) **Field of Search** D26/37-50; 362/157,
362/158, 171, 173, 175, 183-208

The ornamental design for a railroad flashlight, as shown and described.

DESCRIPTION

(56) **References Cited**

U.S. PATENT DOCUMENTS

D. 318,337	*	7/1991	Taylor et al.	D26/42
D. 408,090	*	4/1999	Monteleone et al.	D26/49
D. 435,922	*	1/2001	Shing	D26/49
1,363,664		12/1920	Livingston .	
1,445,483		2/1923	Burke .	
1,530,206		3/1925	Saager .	
2,225,825		12/1940	Desimone	240/10.6
2,647,254		7/1953	Brunnhoezl	340/321
2,838,750		6/1958	Rose	340/321
2,855,499		10/1958	Lewis	240/10.6
4,656,566		4/1987	Kelley	362/202
5,383,103		1/1995	Pasch et al.	362/102
5,392,203		2/1995	Harris, Jr.	362/186

FIG. 1 is a perspective view illustrating the front and side, according to the present invention;
 FIG. 2 is a perspective view illustrating the back and side, according to the present invention
 FIG. 3 is a view of the front, according to the present invention;
 FIG. 4 is a view of the back, according to the present invention;
 FIG. 5 is a view of the side, according to the present invention;
 FIG. 6 is a view of another side, according to the present invention; and,
 FIG. 7 is a view of the another side, according to the present invention.

1 Claim, 7 Drawing Sheets

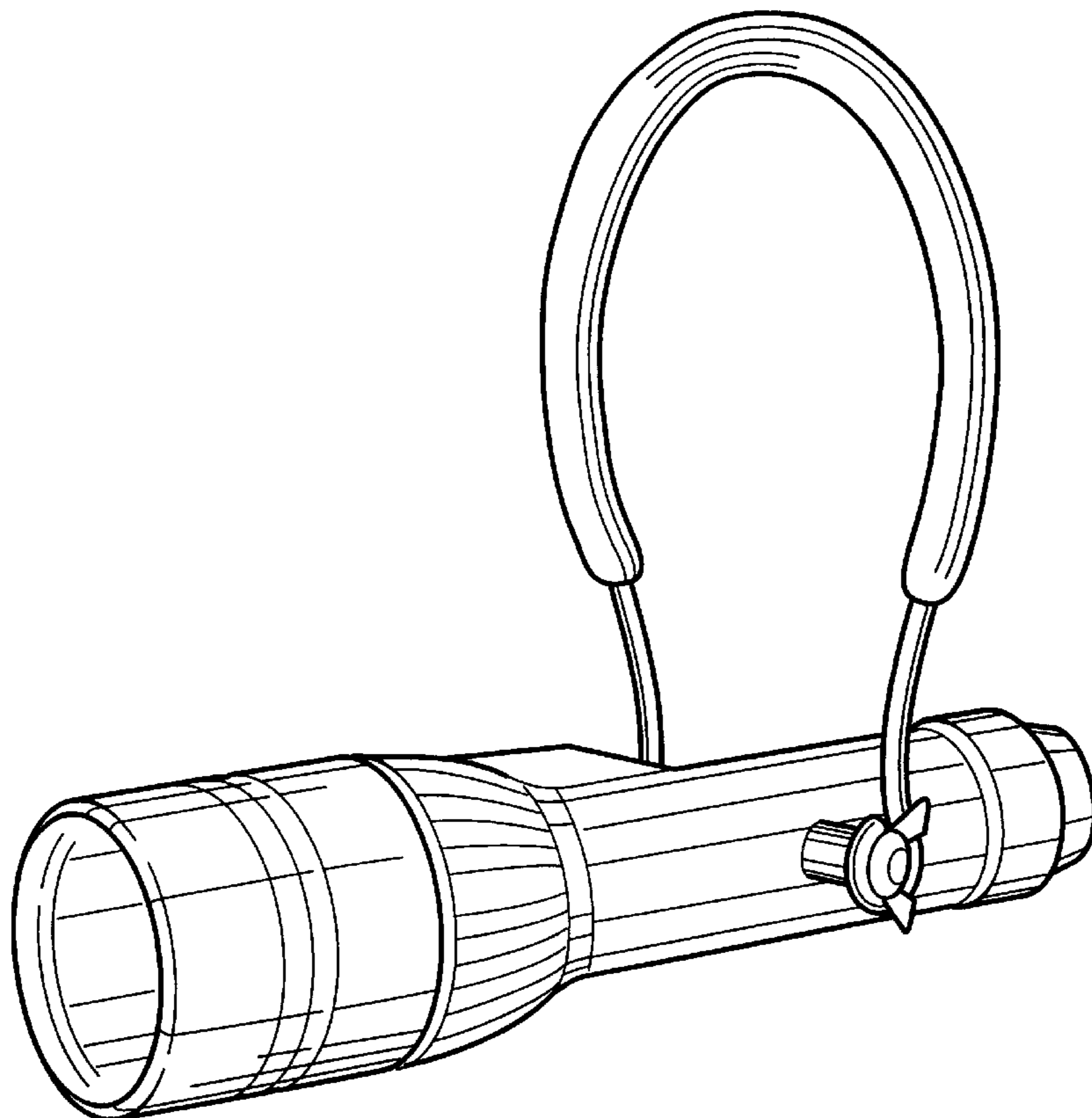

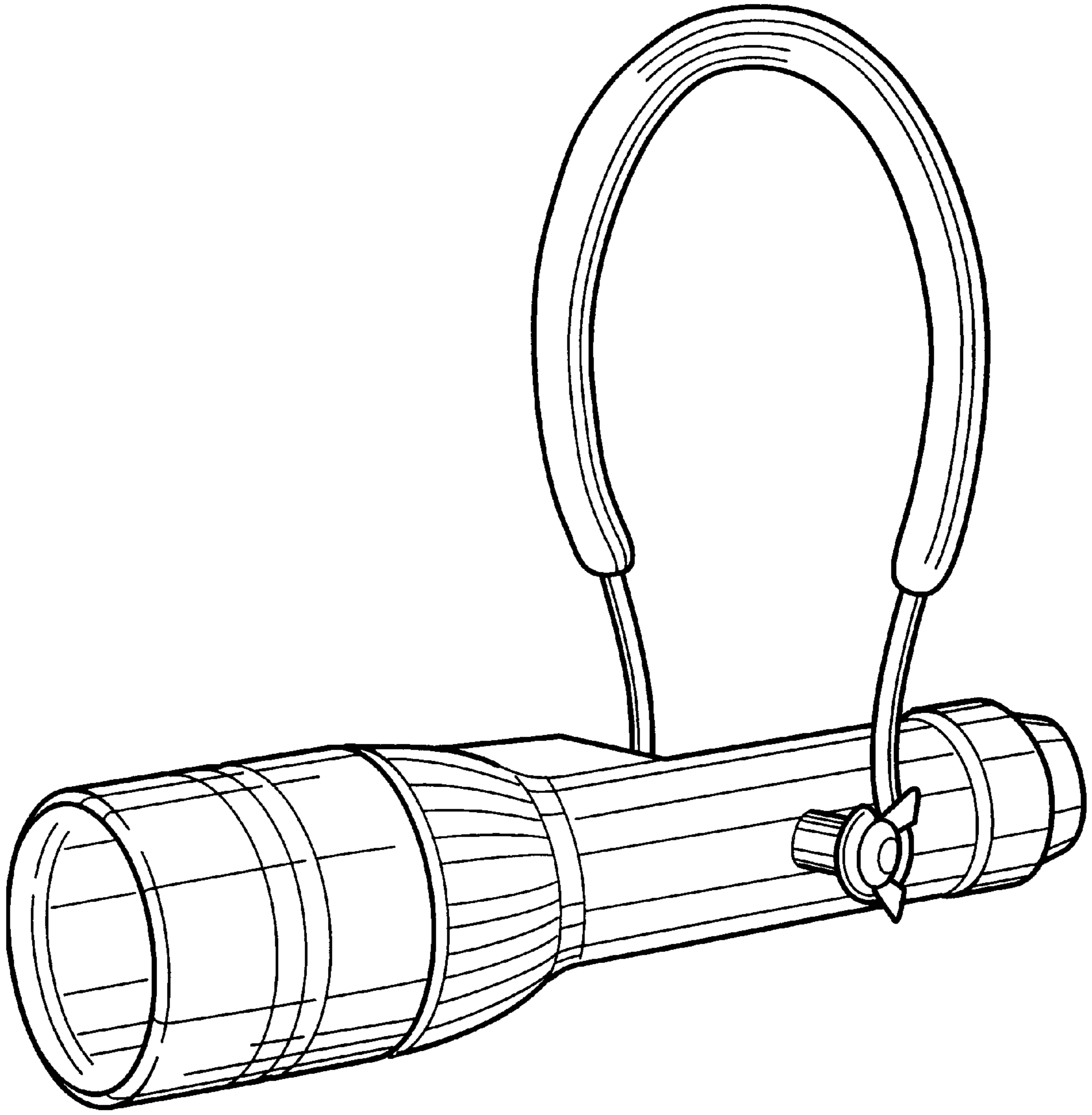

Fig. 1

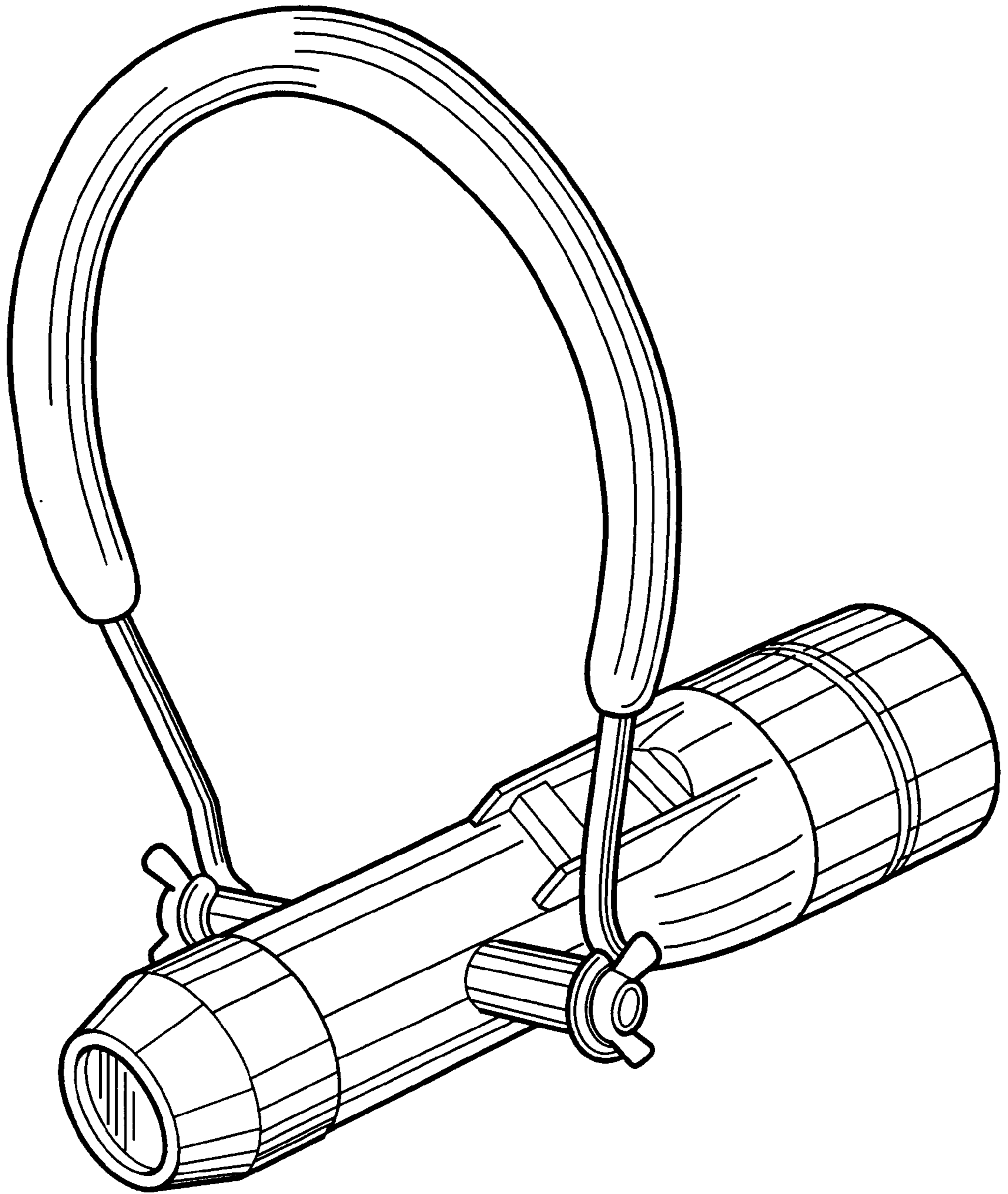

Fig. 2

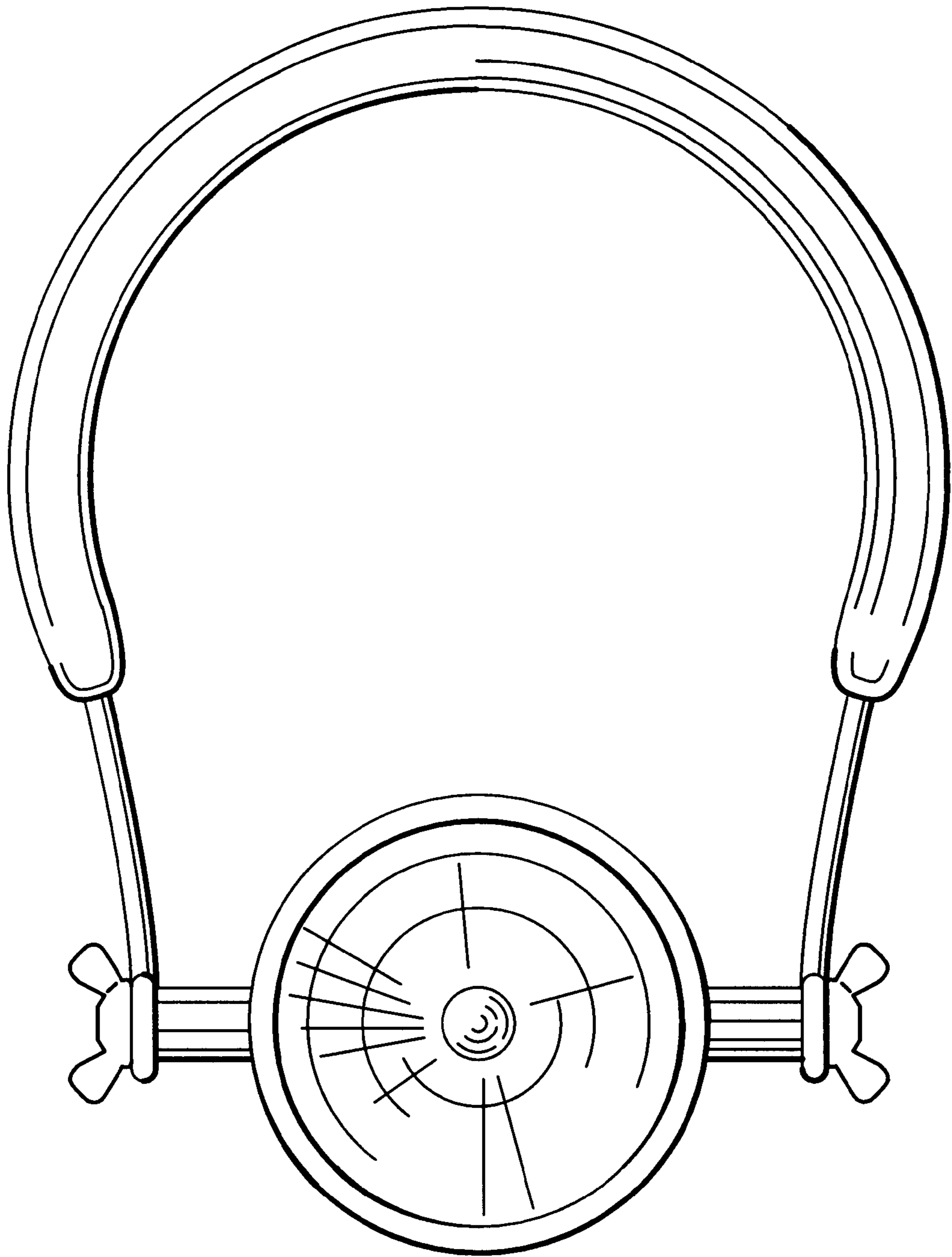

Fig. 3

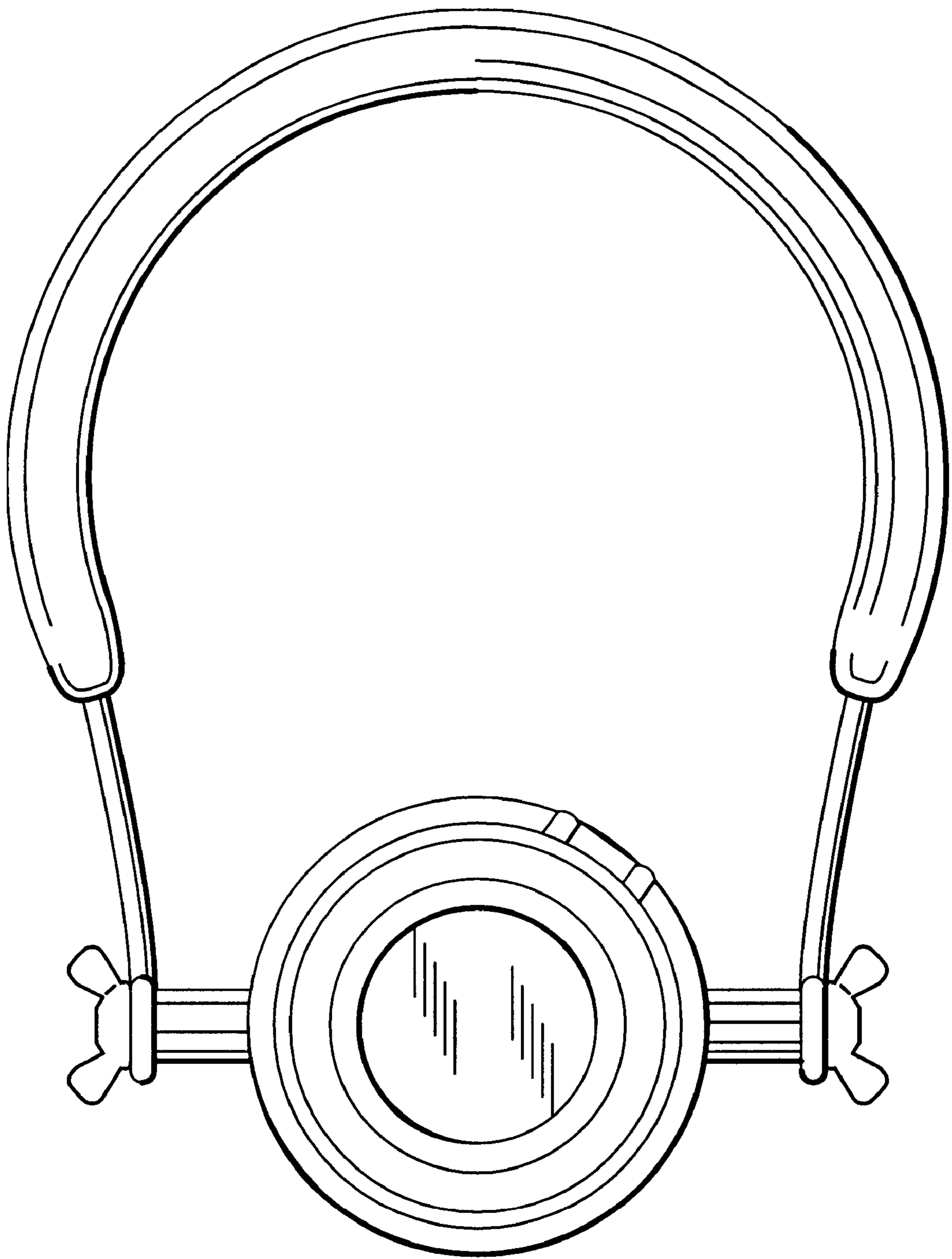

Fig. 4

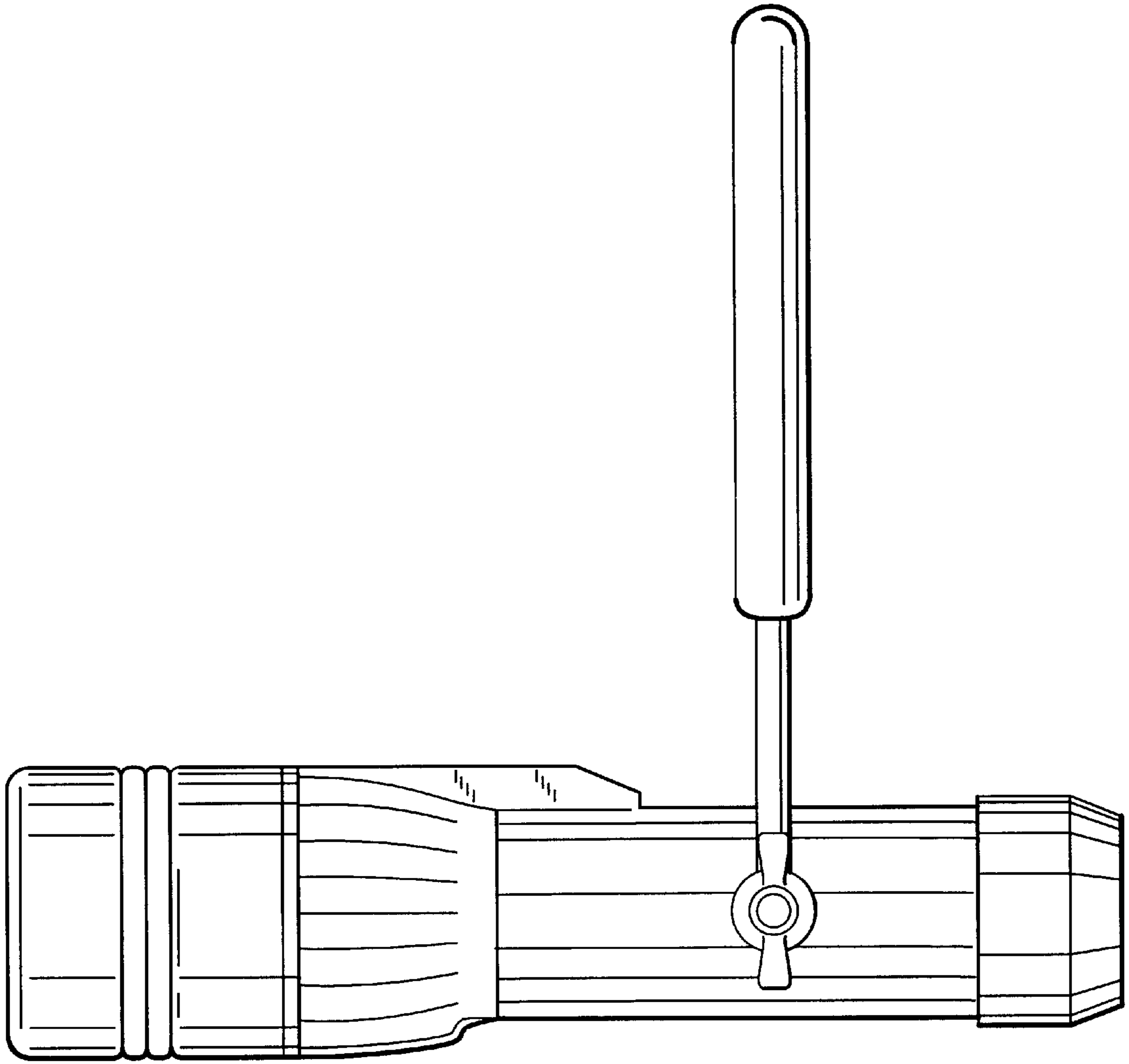

Fig. 5

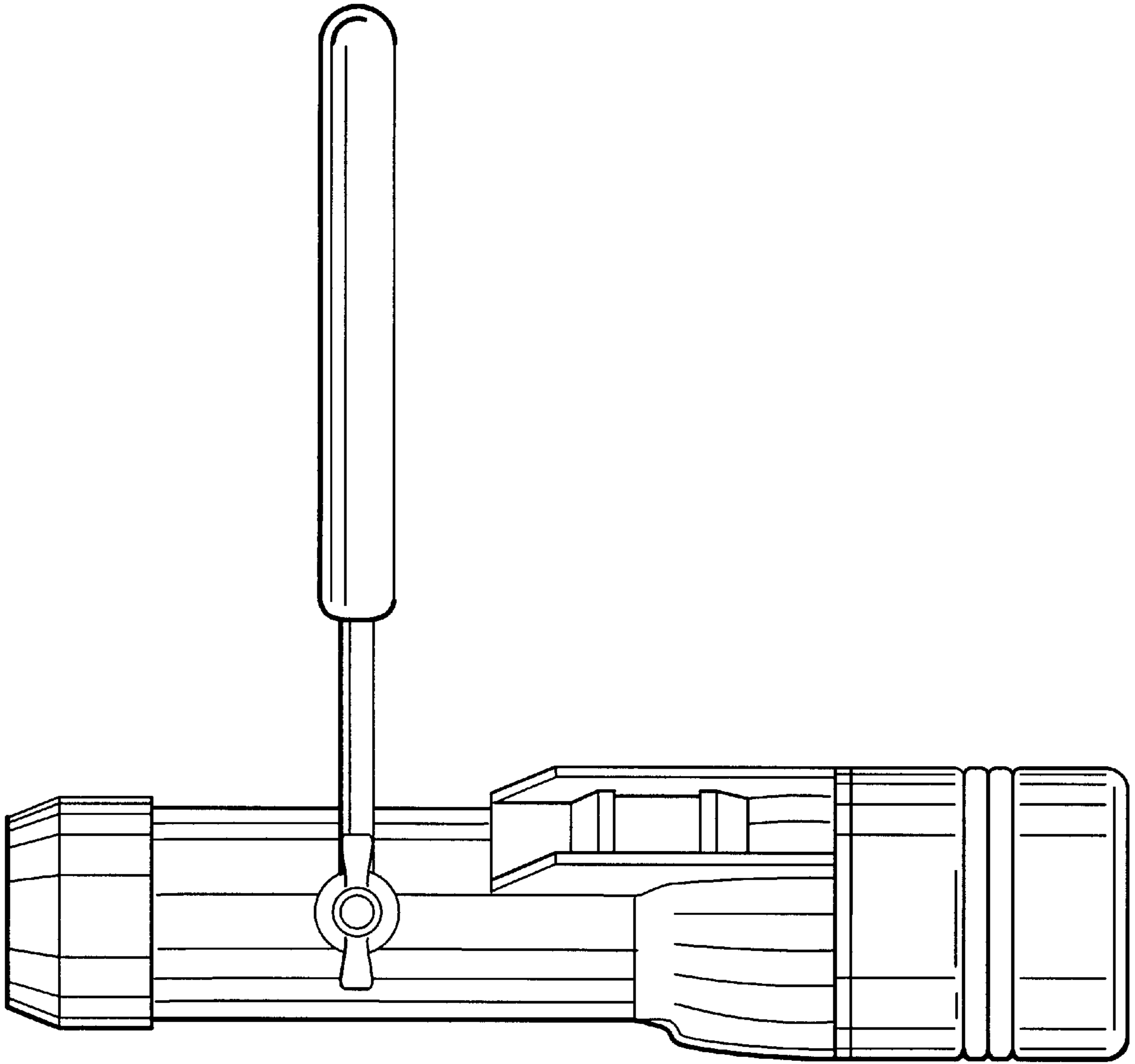

Fig. 6

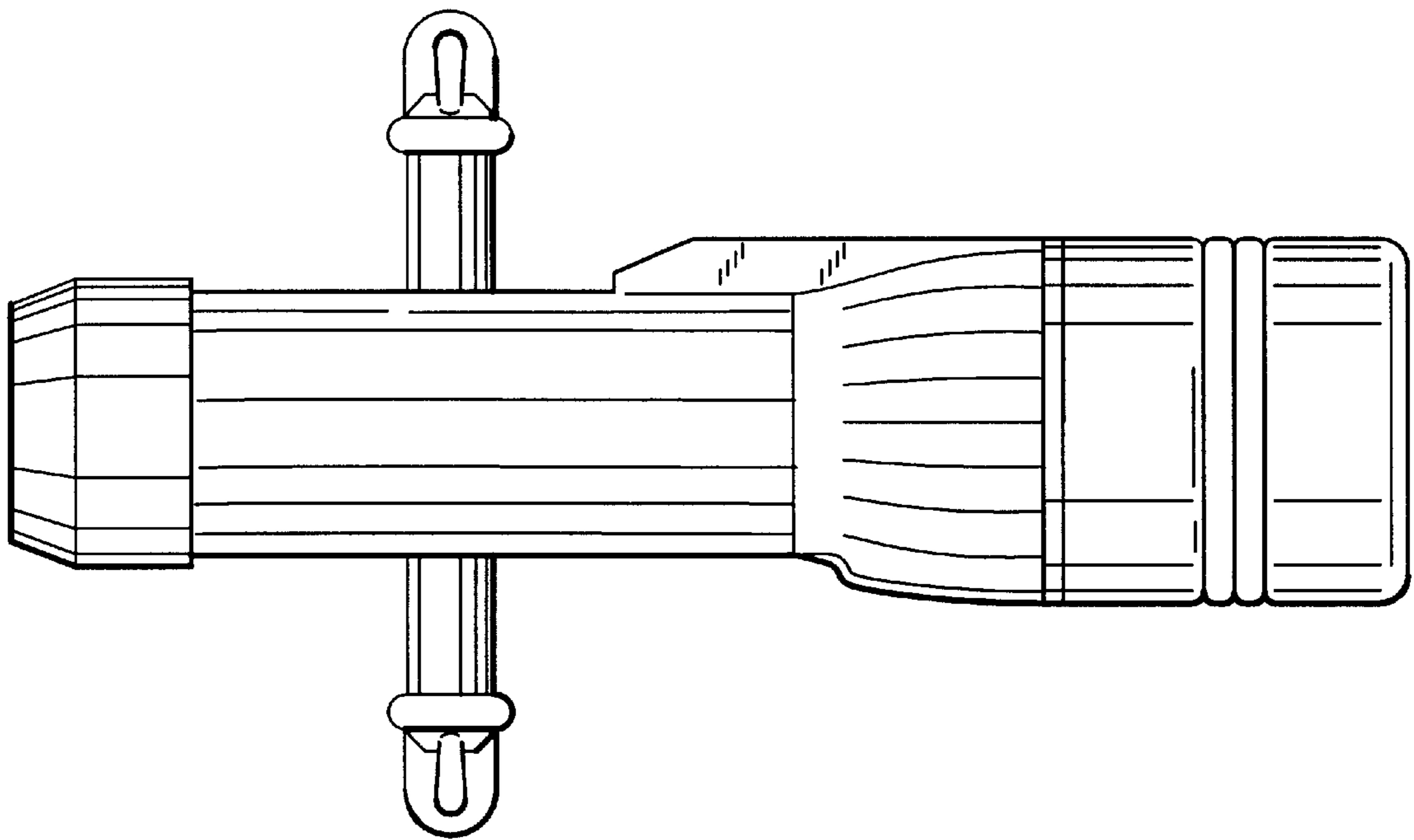

Fig. 7