



US00D445086S

(12) **United States Design Patent**
Moshier

(10) **Patent No.:** **US D445,086 S**

(45) **Date of Patent:** **** *Jul. 17, 2001**

(54) **AIRCRAFT**

FOREIGN PATENT DOCUMENTS

(75) **Inventor:** **Michael Moshier**, Los Altos Hills, CA
(US)

2628 274 A1 1/1978 (DE) .

* cited by examiner

(73) **Assignee:** **Millennium Jet, Inc.**, Sunnyvale, CA
(US)

Primary Examiner—Kay H. Chin

(74) *Attorney, Agent, or Firm*—Knobbe, Martens, Olson &
Bear, LLP

(**) **Term:** **14 Years**

(57) **CLAIM**

(21) **Appl. No.:** **29/089,932**

The ornamental design for an aircraft, as shown and
described.

(22) **Filed:** **Jun. 26, 1998**

(51) **LOC (7) Cl.** **12-07**

(52) **U.S. Cl.** **D12/319; D12/326**

(58) **Field of Search** **D12/319-345;**
244/17.17, 100 R, 17.11, 4 R

DESCRIPTION

FIG. 1 is a front elevational view of the aircraft of the
present invention, a passenger thereof shown in phantom;
FIG. 2 is a rear elevational view thereof;
FIG. 3 is a left side elevational view thereof;
FIG. 4 is a right side elevational view thereof;
FIG. 5 is a top plan view thereof;
FIG. 6 is a bottom plan view thereof; and,
FIG. 7 is a perspective view of the aircraft seen from above,
in front, and to the right of the aircraft.
Phantom lining, where utilized, is for illustrative purposes
only and is not intended to limit the claimed design to the
features shown in phantom.

(56) **References Cited**

U.S. PATENT DOCUMENTS

D. 243,594	3/1977	Koch .	
3,149,799	9/1964	Hulbert .	
3,173,629	3/1965	Uhor .	
3,314,628 *	4/1967	Myers	244/17.17
3,474,987	10/1969	Meditz .	
3,556,438	1/1971	Meditz .	
3,586,263	6/1971	Payne .	

1 Claim, 4 Drawing Sheets

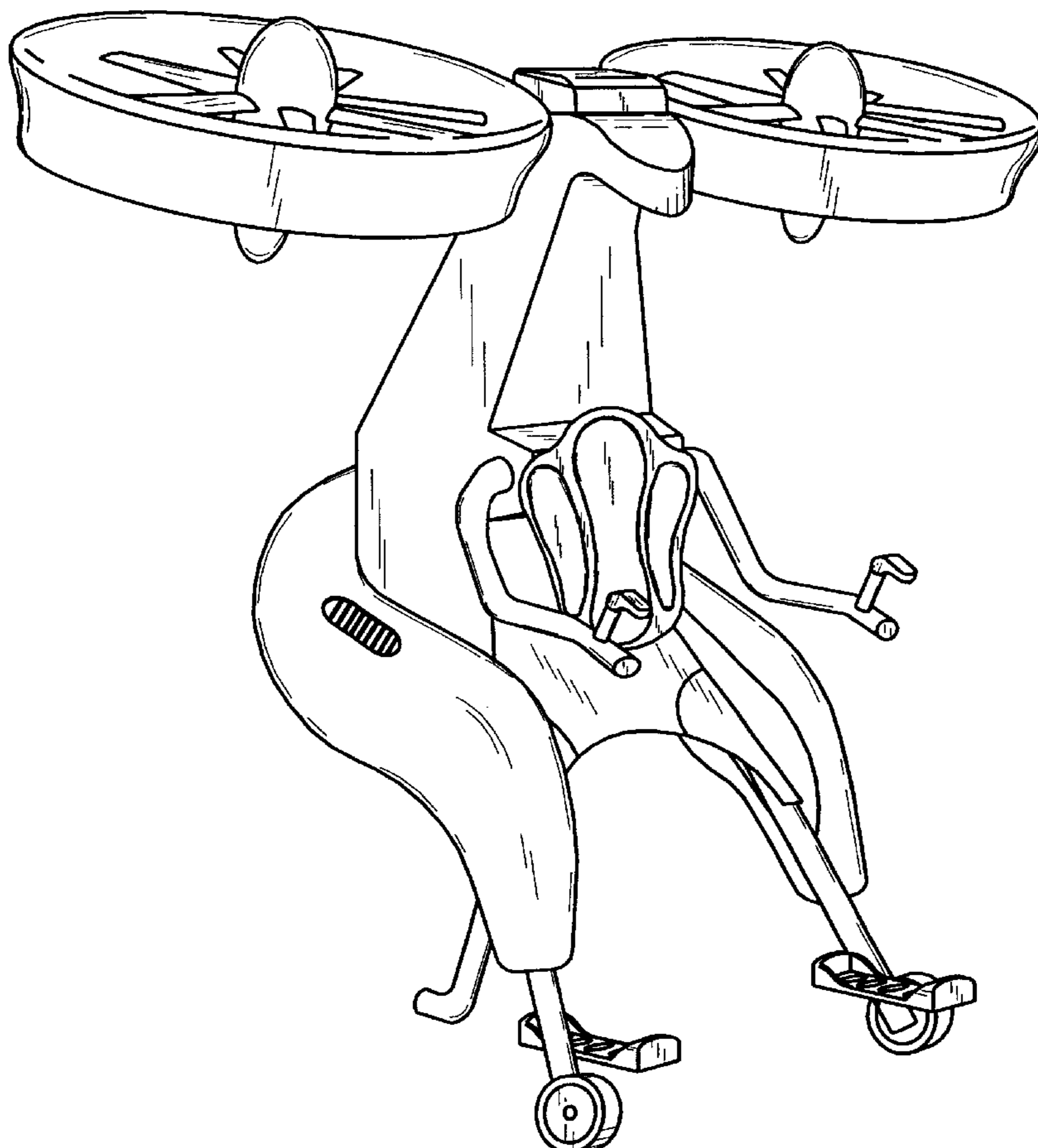

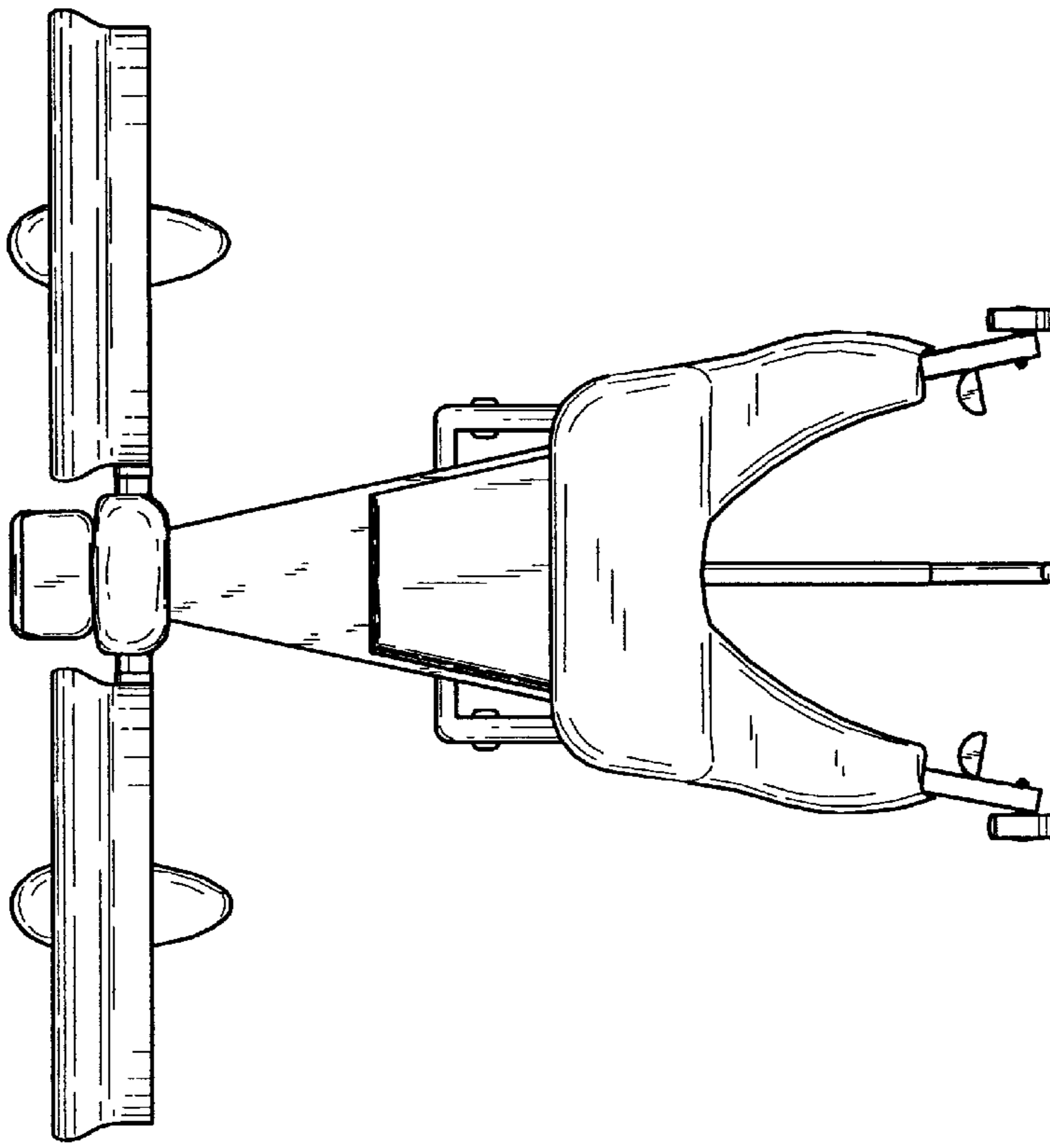

FIG. 2

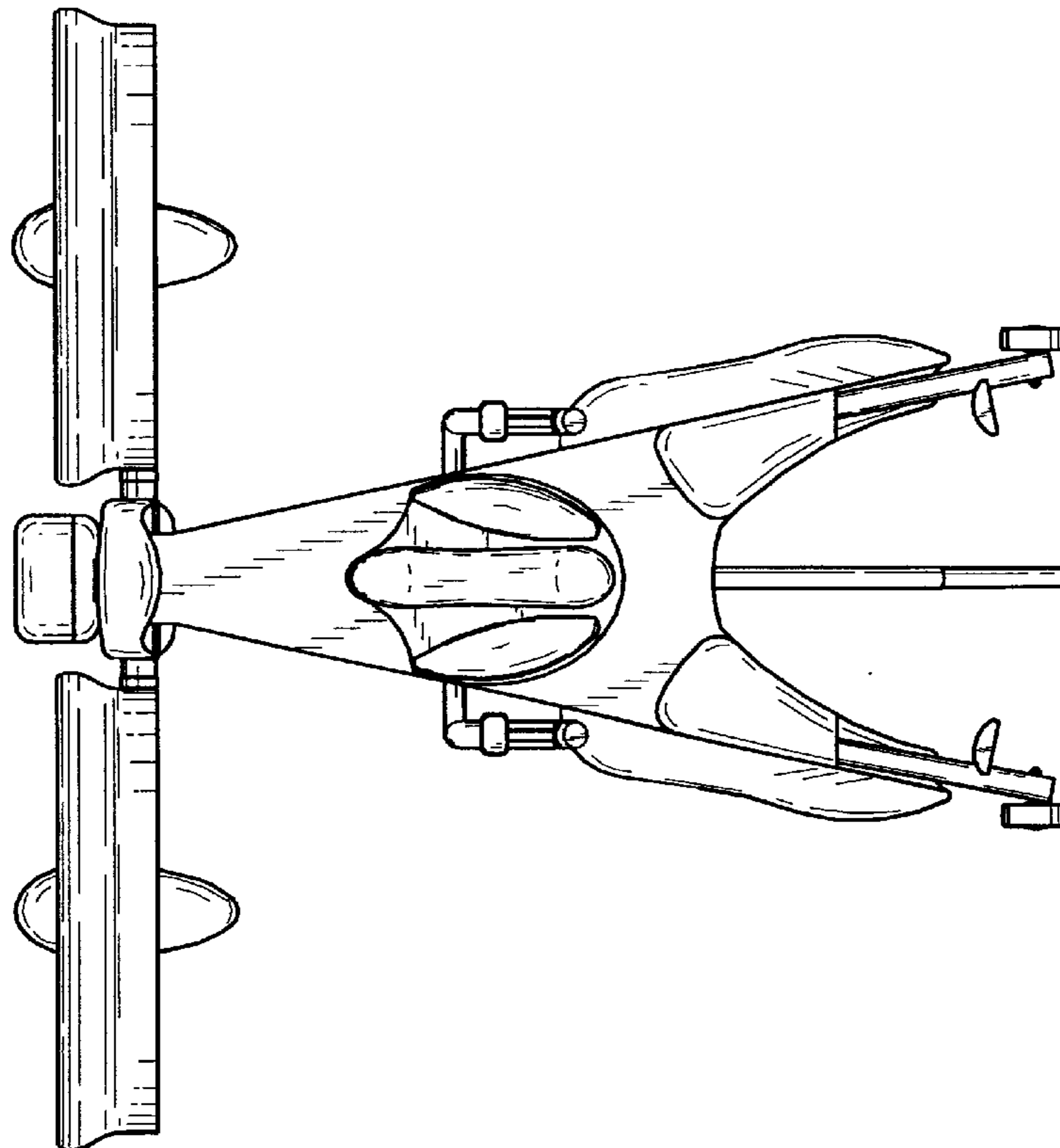

FIG. 1

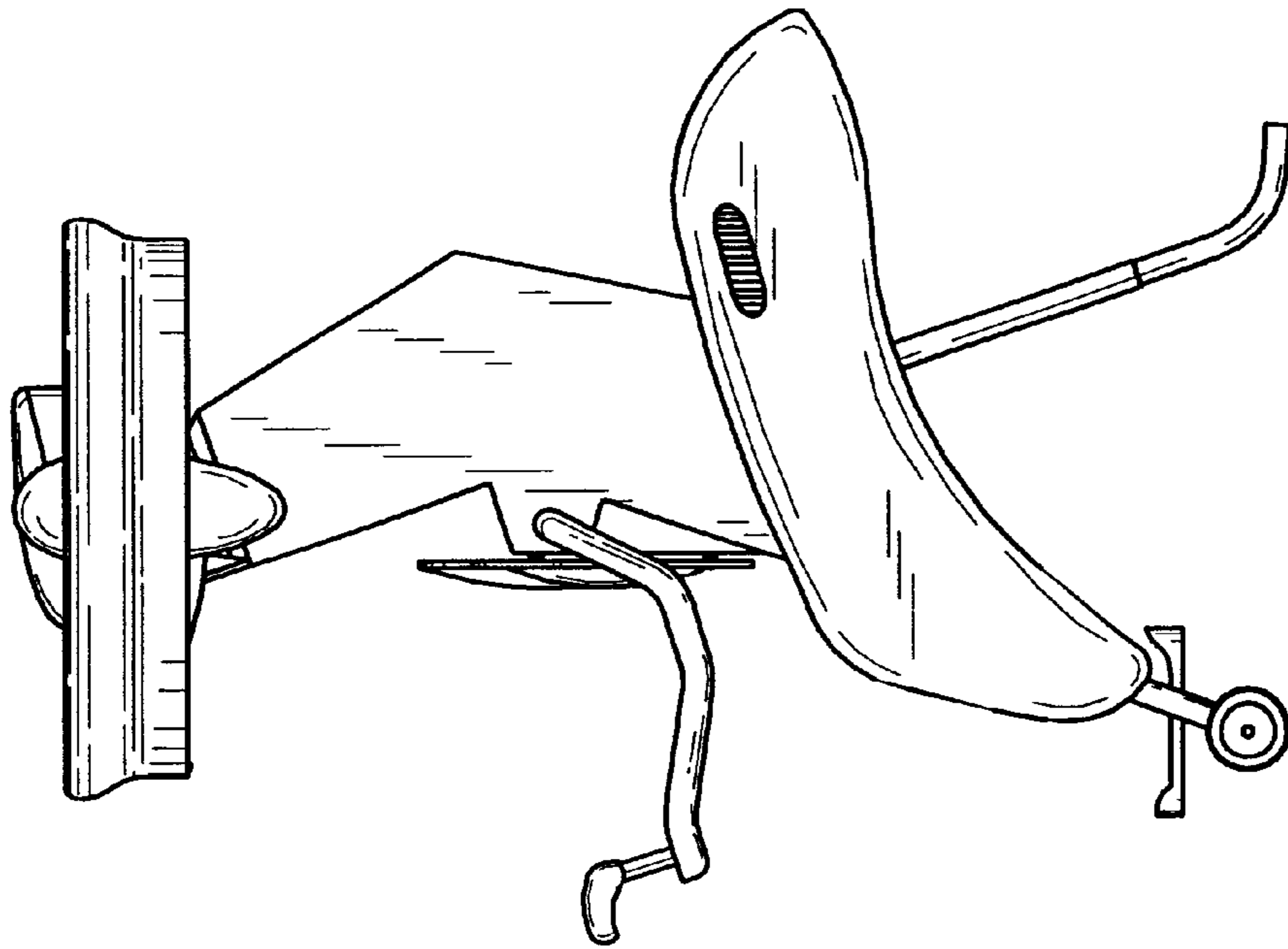

FIG. 4

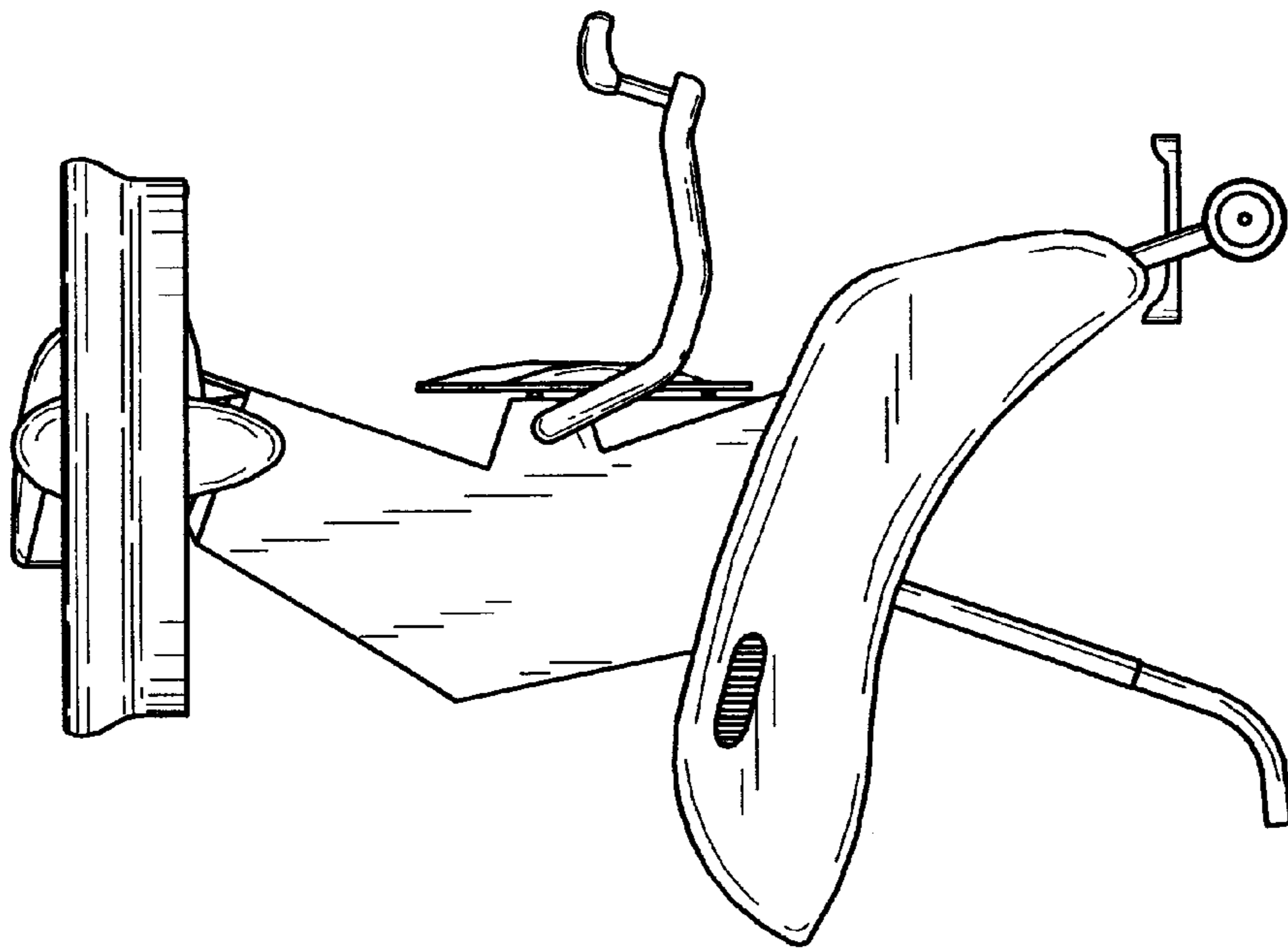

FIG. 3

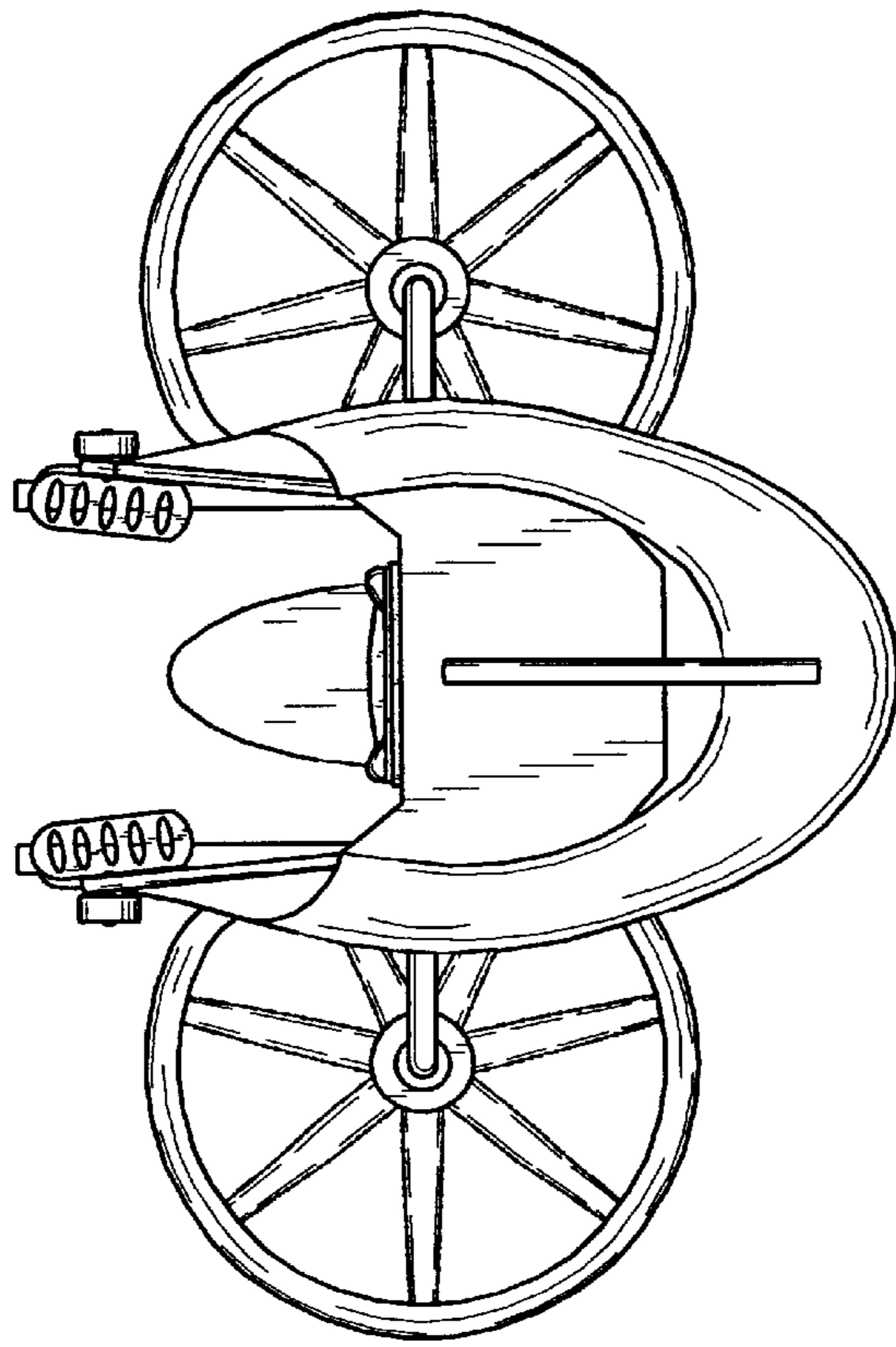

FIG. 6

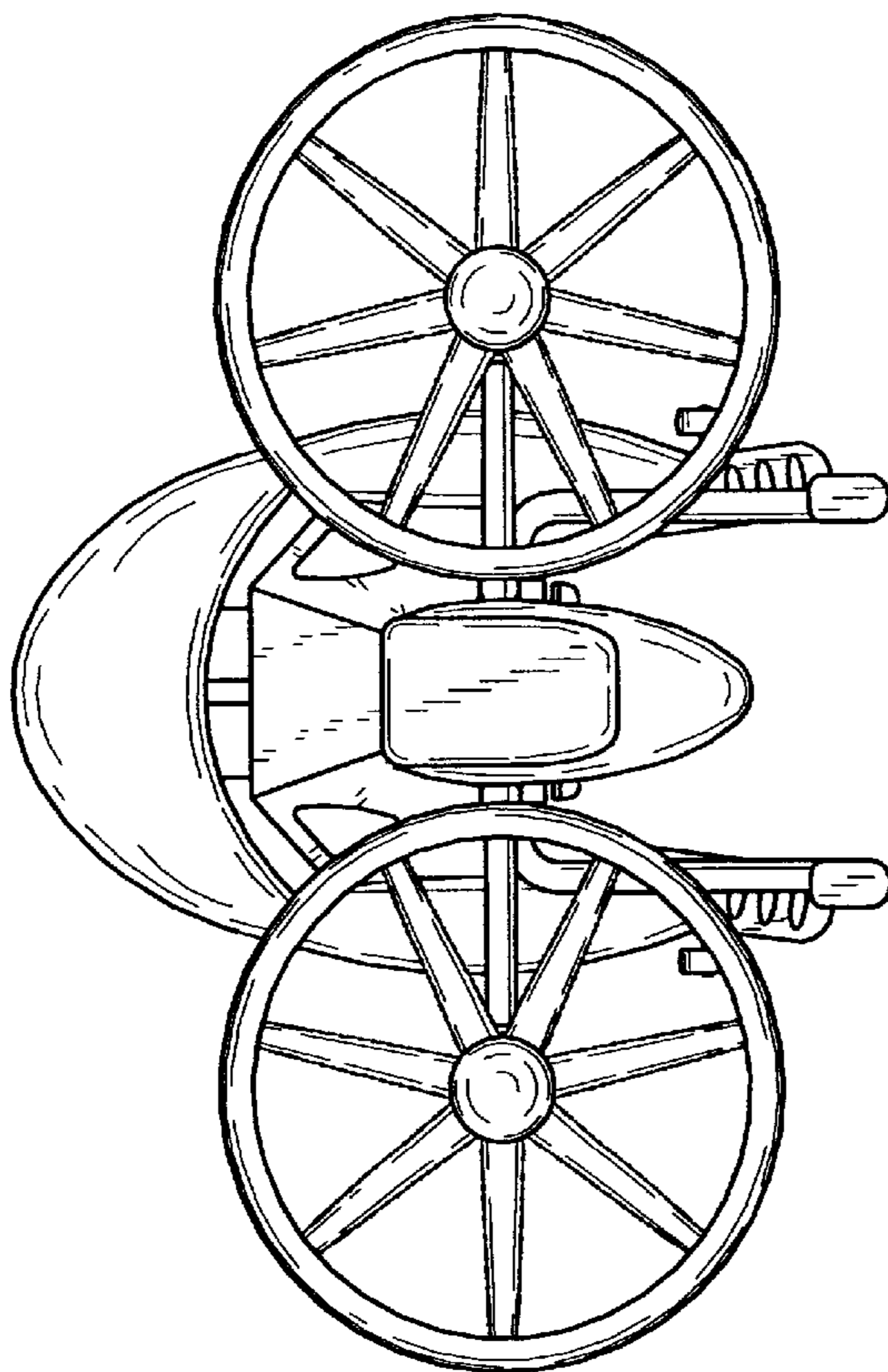

FIG. 5

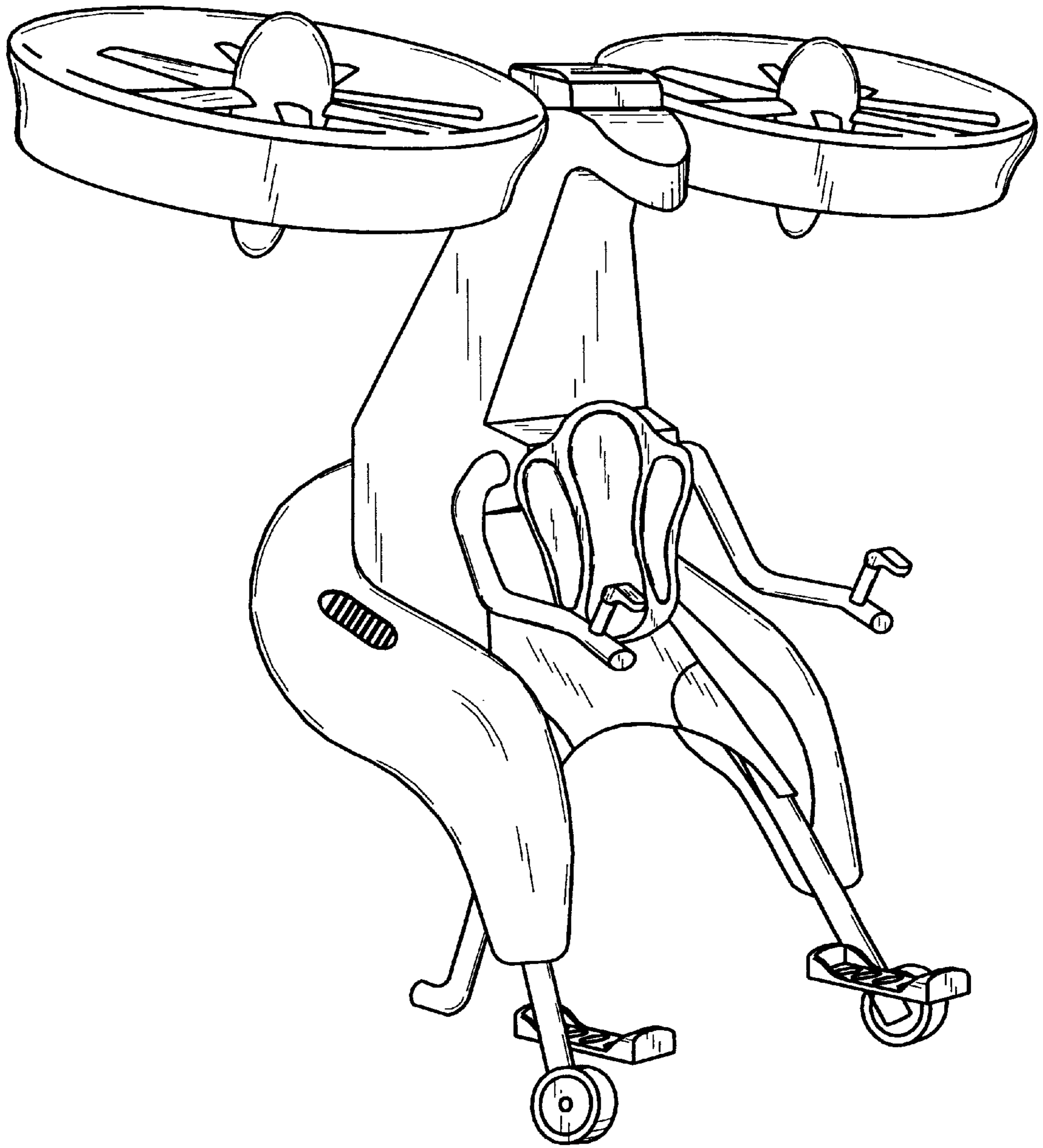

FIG. 7