



US00D445074S

(12) **United States Design Patent**  
**Feuling**

(10) **Patent No.:** **US D445,074 S**

(45) **Date of Patent:** **\*\* Jul. 17, 2001**

(54) **EXHAUST SYSTEM FOR A MOTORCYCLE**

D. 385,523 \* 10/1997 Borla ..... D12/194

D. 399,467 \* 10/1998 Erion et al. .... D12/194

D. 414,452 \* 9/1999 Verlengiere ..... D12/194

(76) **Inventor:** **James J. Feuling**, 2521 Palma Dr.,  
Ventura, CA (US) 93003

\* cited by examiner

(\*\*) **Term:** **14 Years**

*Primary Examiner*—Stacia Cadmus

(21) **Appl. No.:** **29/112,795**

(74) *Attorney, Agent, or Firm*—Kelly Bauersfeld Lowry &  
Kelley, LLP

(22) **Filed:** **Oct. 25, 1999**

(57) **CLAIM**

(51) **LOC (7) Cl.** ..... **12-16**

The ornamental design for a exhaust system for a motor-  
cycle, as shown and described.

(52) **U.S. Cl.** ..... **D12/194**

(58) **Field of Search** ..... D12/194, 114;  
D15/5; 181/227–228, 247–249, 251, 264,  
282; 60/313, 323, 302, 299; 123/312, 315;  
239/127; 29/890.08, 282, 39.5, 39.04

**DESCRIPTION**

(56) **References Cited**

FIG. 1 is a right view of an exhaust system for a motorcycle,  
showing my new design;  
FIG. 2 is an enlarged right view thereof;  
FIG. 3 is an enlarged top view thereof;  
FIG. 4 is an enlarged front view thereof;  
FIG. 5 is an enlarged left view thereof;  
FIG. 6 is an enlarged rear view thereof; and,  
FIG. 7 is an enlarged bottom view thereof.

**U.S. PATENT DOCUMENTS**

The broken line showing of environment is for illustrative  
purposes only and forms no part of the claimed design.

D. 134,462 \* 12/1942 Sprague ..... D12/194

D. 228,753 \* 10/1973 Kryssing ..... D12/194

D. 238,267 \* 12/1975 Strada ..... D12/194

D. 238,268 \* 12/1975 Strada ..... D12/194

D. 255,112 \* 5/1980 Alexander ..... D12/194

D. 271,963 \* 12/1983 Perkins ..... D12/194

D. 291,576 \* 8/1987 Wilkinson ..... D15/5

D. 368,247 \* 3/1996 Jones ..... D12/194

**1 Claim, 2 Drawing Sheets**

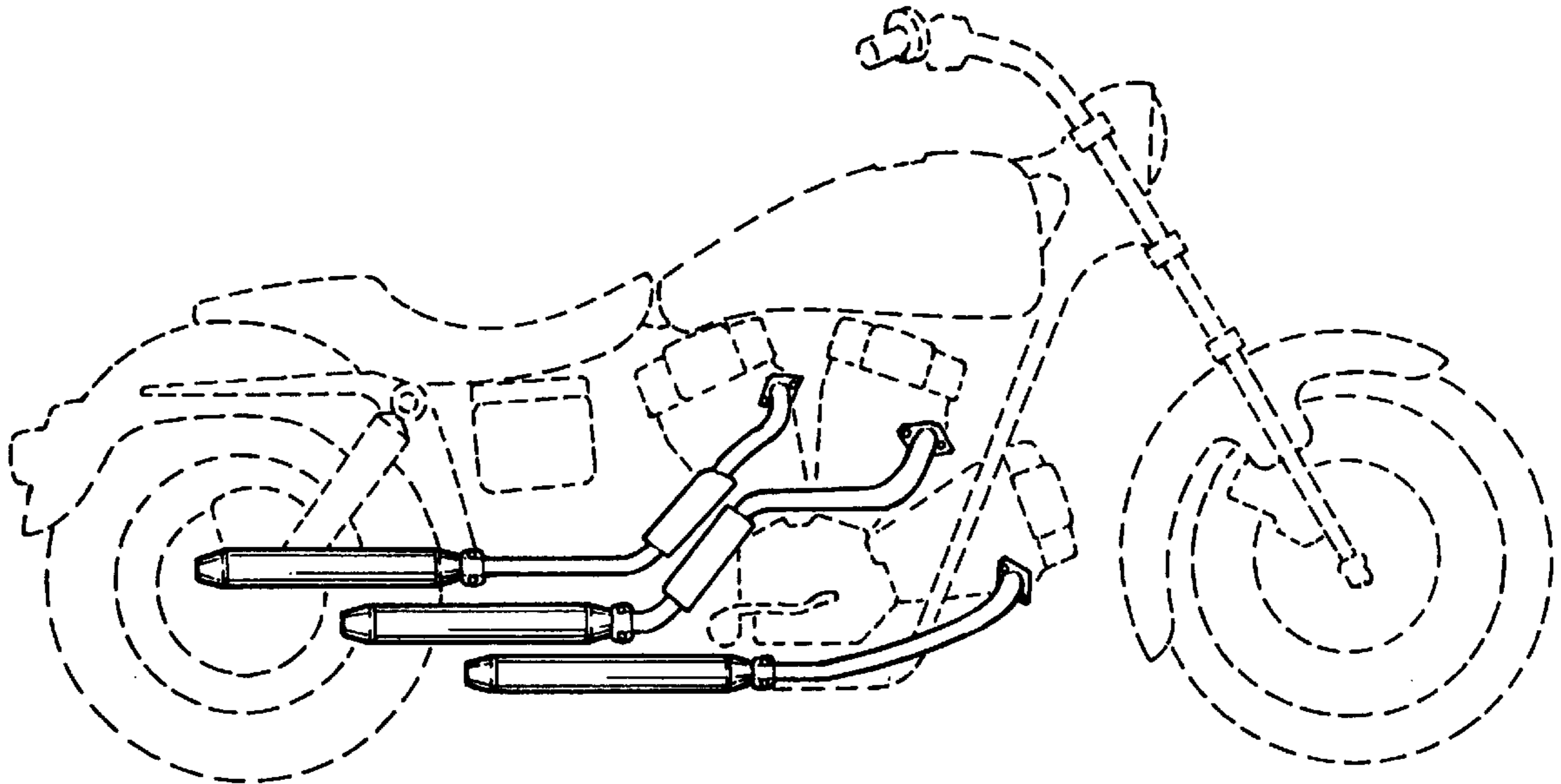

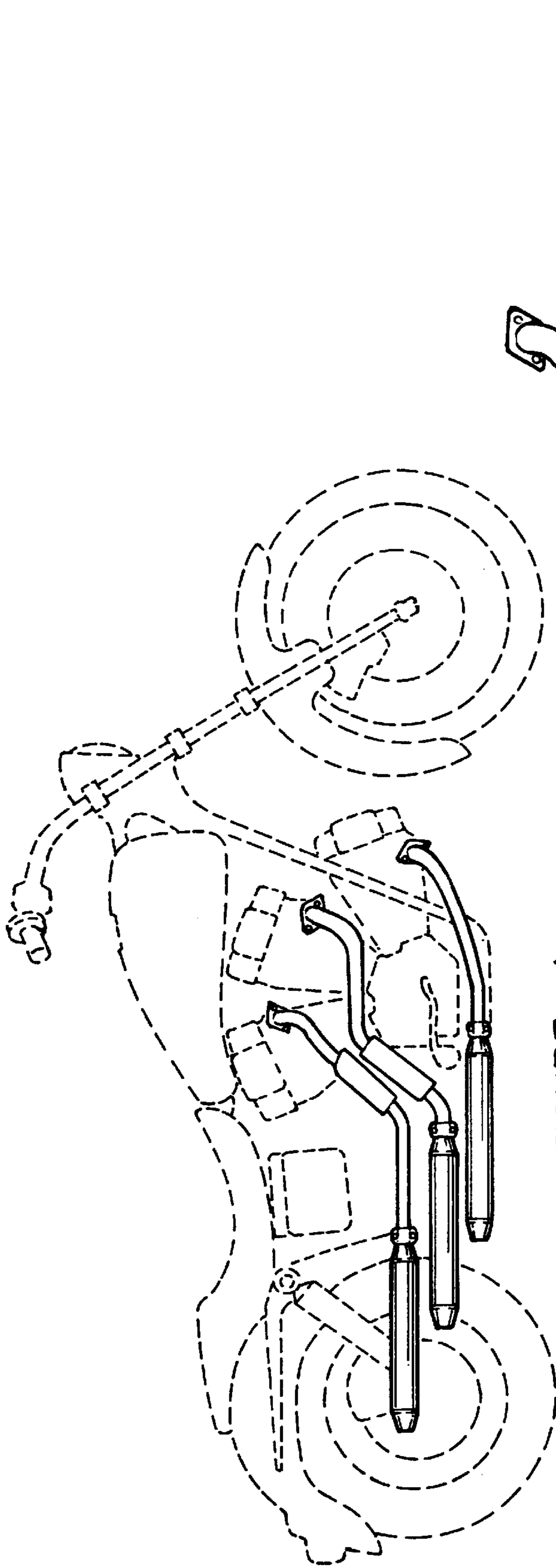

FIGURE 1

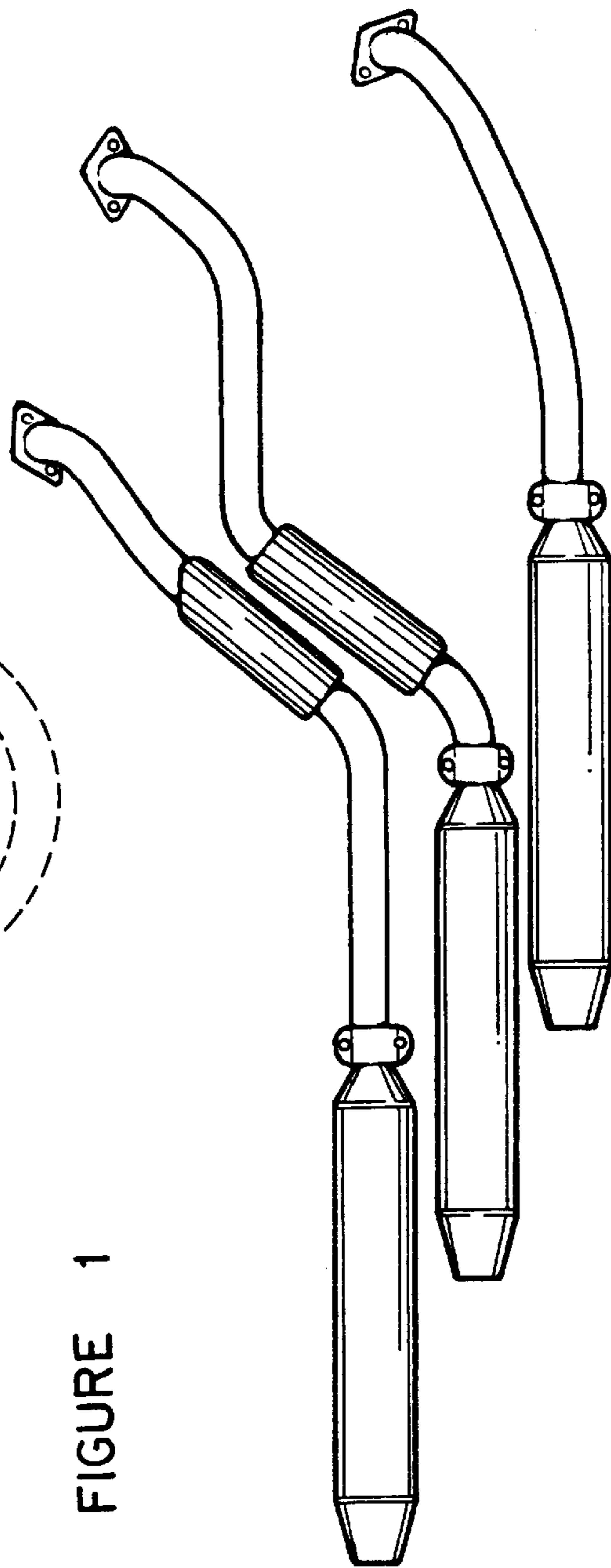

FIGURE 2

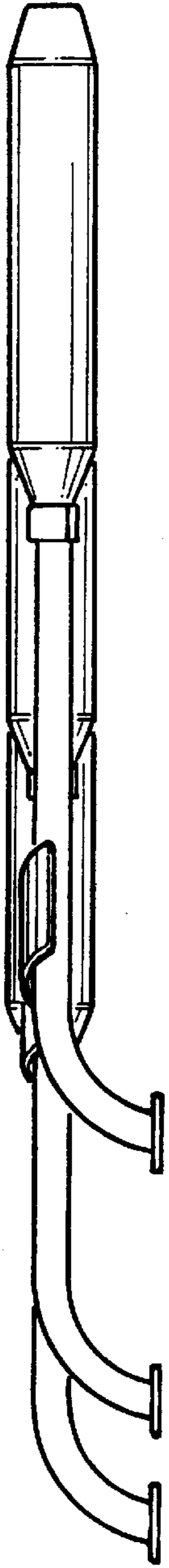

FIGURE 3

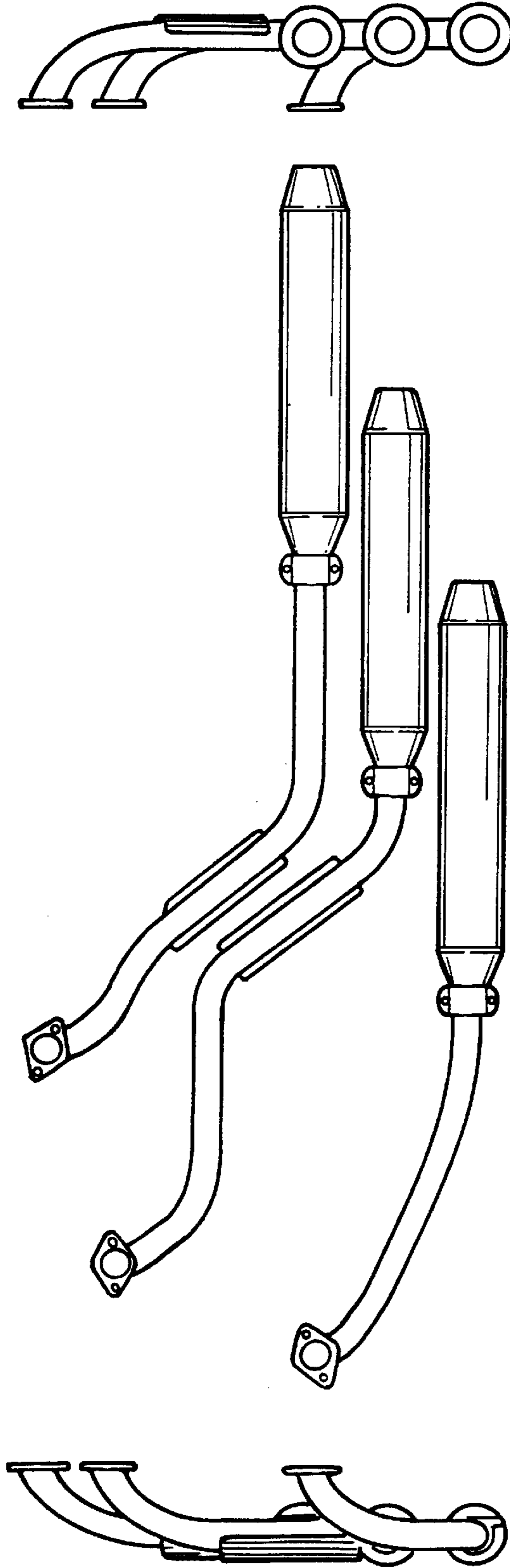

FIGURE 4

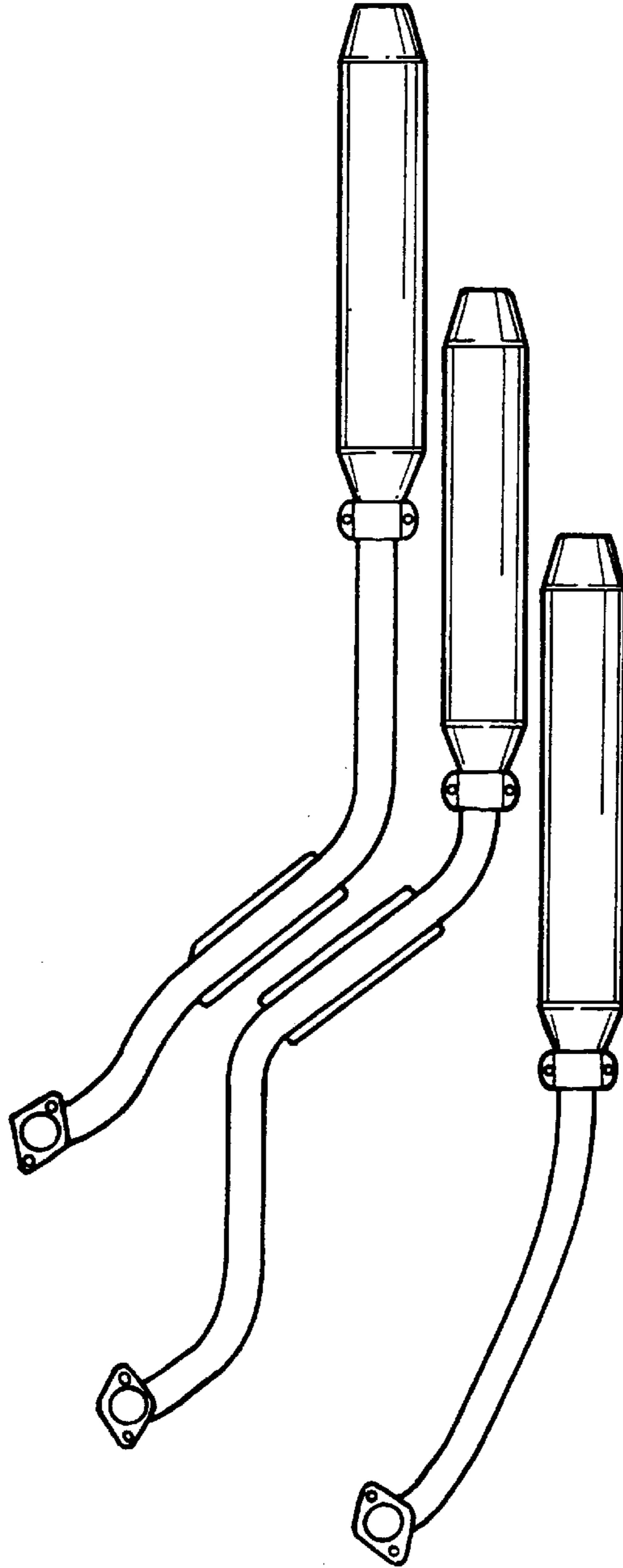

FIGURE 5



FIGURE 7

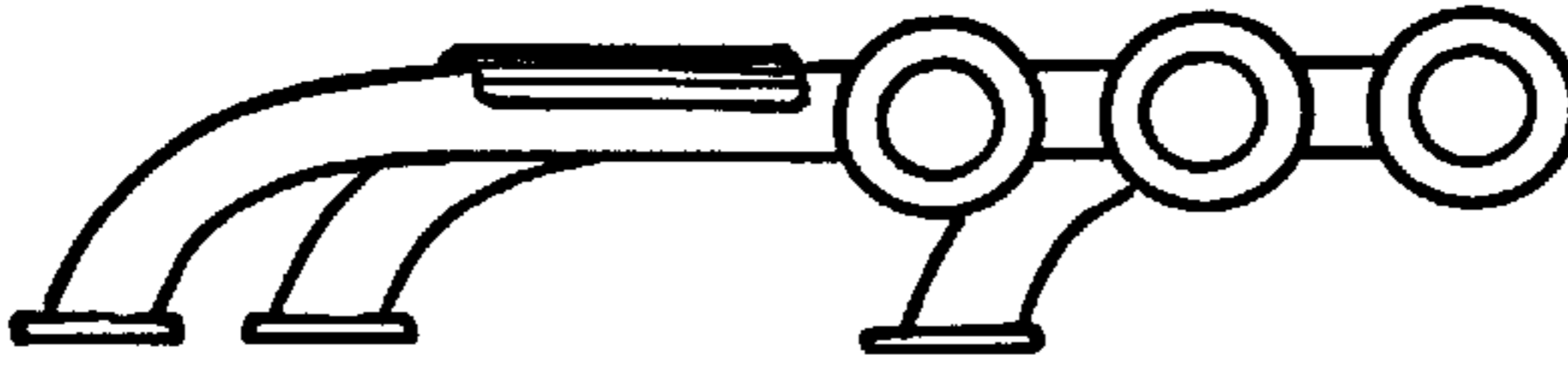

FIGURE 6