



US00D444848S

(12) **United States Design Patent**
Heren

(10) **Patent No.:** **US D444,848 S**

(45) **Date of Patent:** **** Jul. 10, 2001**

(54) **FLOW CONTROL ROTOR MODULE**

4,819,875 * 4/1989 Beal 239/230
5,647,541 * 7/1997 Nelson 239/230

(75) Inventor: **Lawrence P. Heren**, East Peoria, IL
(US)

* cited by examiner

(73) Assignee: **L. R. Nelson Corporation**, Peoria, IL
(US)

Primary Examiner—Robin V. Taylor

(74) *Attorney, Agent, or Firm*—Mayer, Brown & Platt

(**) Term: **14 Years**

(57) **CLAIM**

The ornamental design for a flow control rotor module, as shown and described.

(21) Appl. No.: **29/127,827**

(22) Filed: **Aug. 11, 2000**

DESCRIPTION

(51) **LOC (7) Cl.** **23-01**

(52) **U.S. Cl.** **D23/214**

(58) **Field of Search** D23/214, 217,
D23/219; 239/273, 276, 581.1, 230

FIG. 1 is a front perspective view of a flow control rotor module;

FIG. 2 is a top plan view thereof;

FIG. 3 is a bottom plan view thereof;

FIG. 4 is a front elevational view thereof;

FIG. 5 is a right side elevational view thereof;

FIG. 6 is a left side elevational view thereof; and,

FIG. 7 is a rear elevational view thereof.

The broken lines shown in FIG. 3 are for illustrative purposes only and form no part of the claimed invention.

(56) **References Cited**

U.S. PATENT DOCUMENTS

2,421,551 * 6/1947 Dunham 239/230
3,103,313 * 9/1963 Raem 239/230
3,580,508 * 5/1971 Azusa et al. 239/230

1 Claim, 2 Drawing Sheets

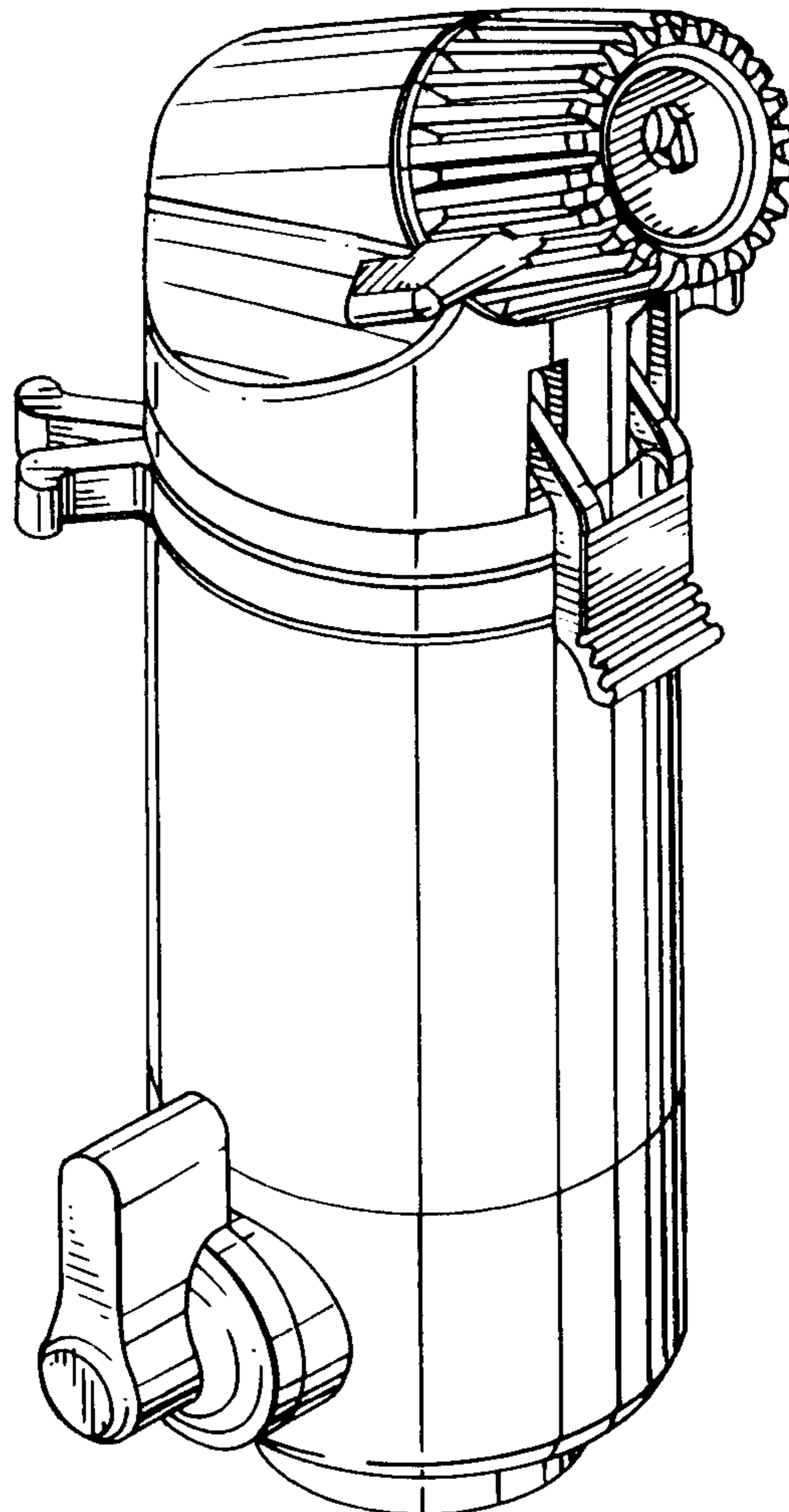

FIG. 1

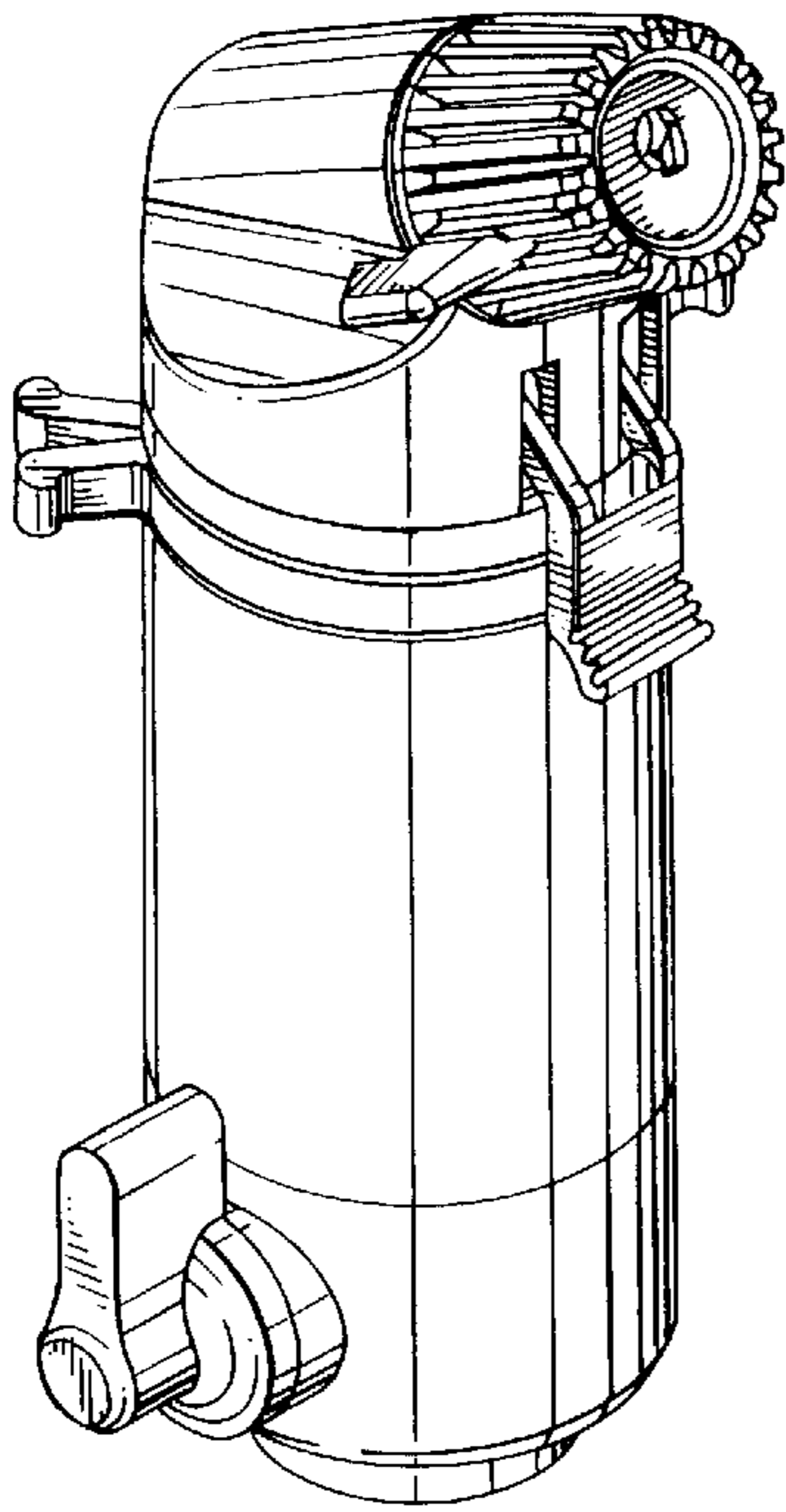

FIG. 2

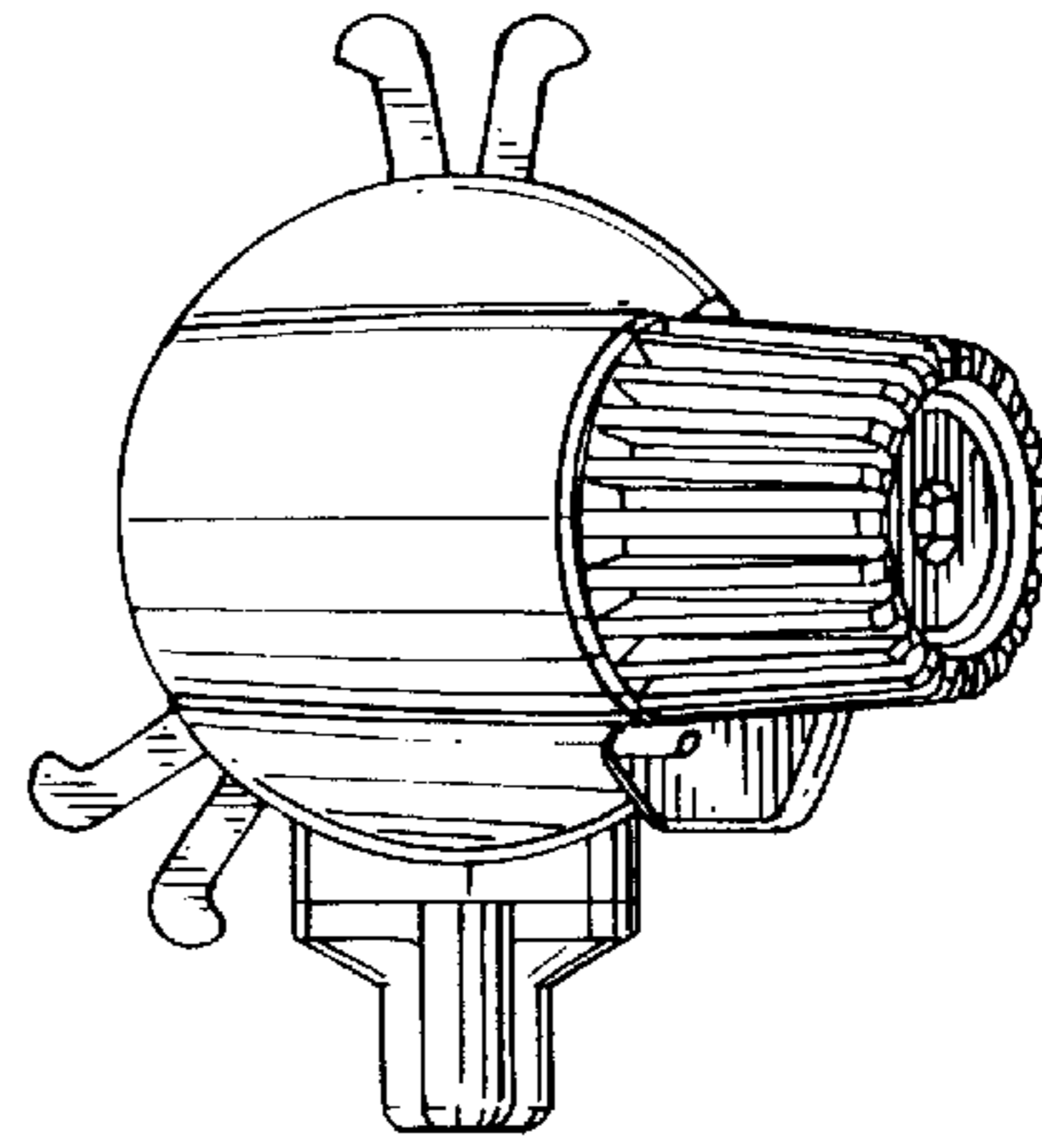

FIG. 4

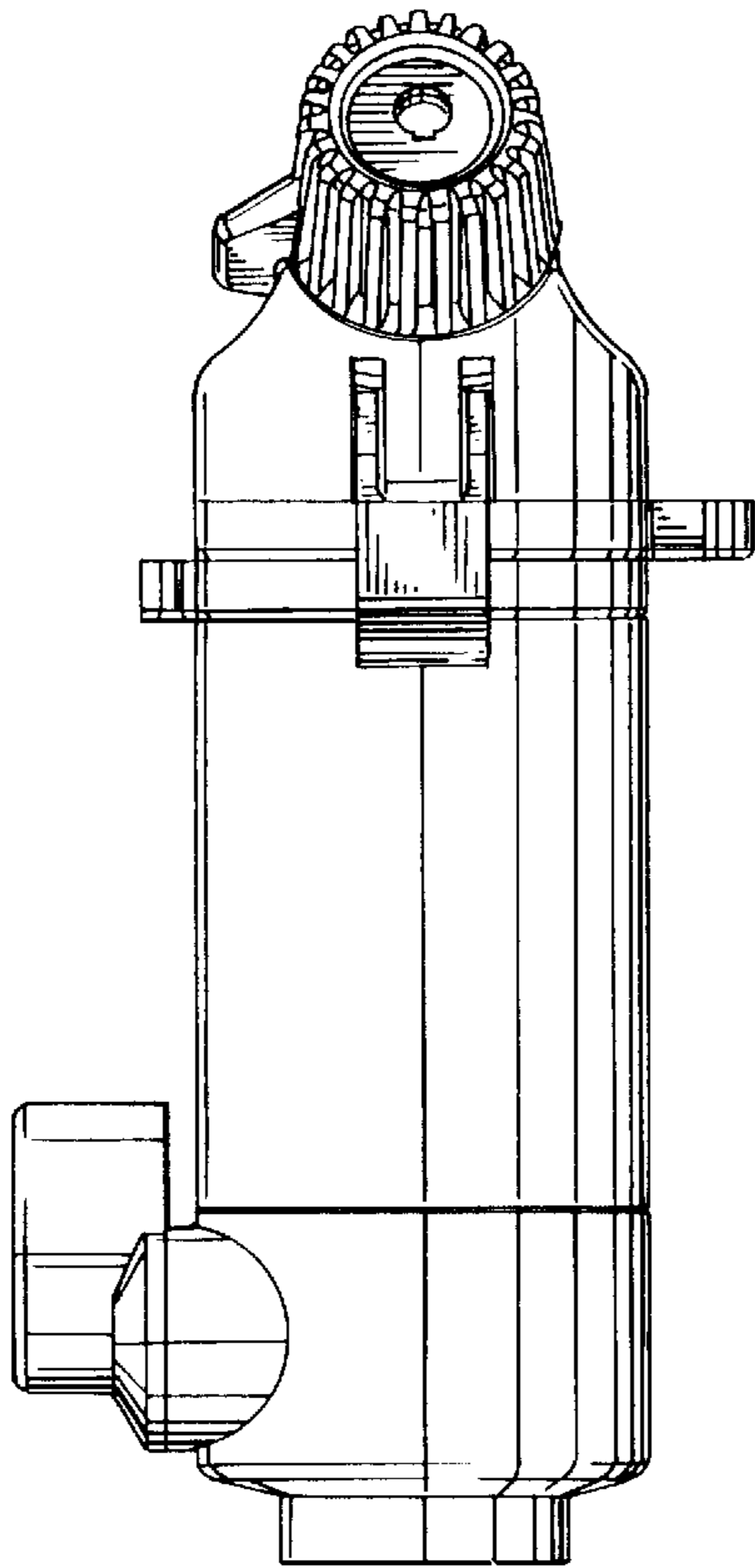

FIG. 3

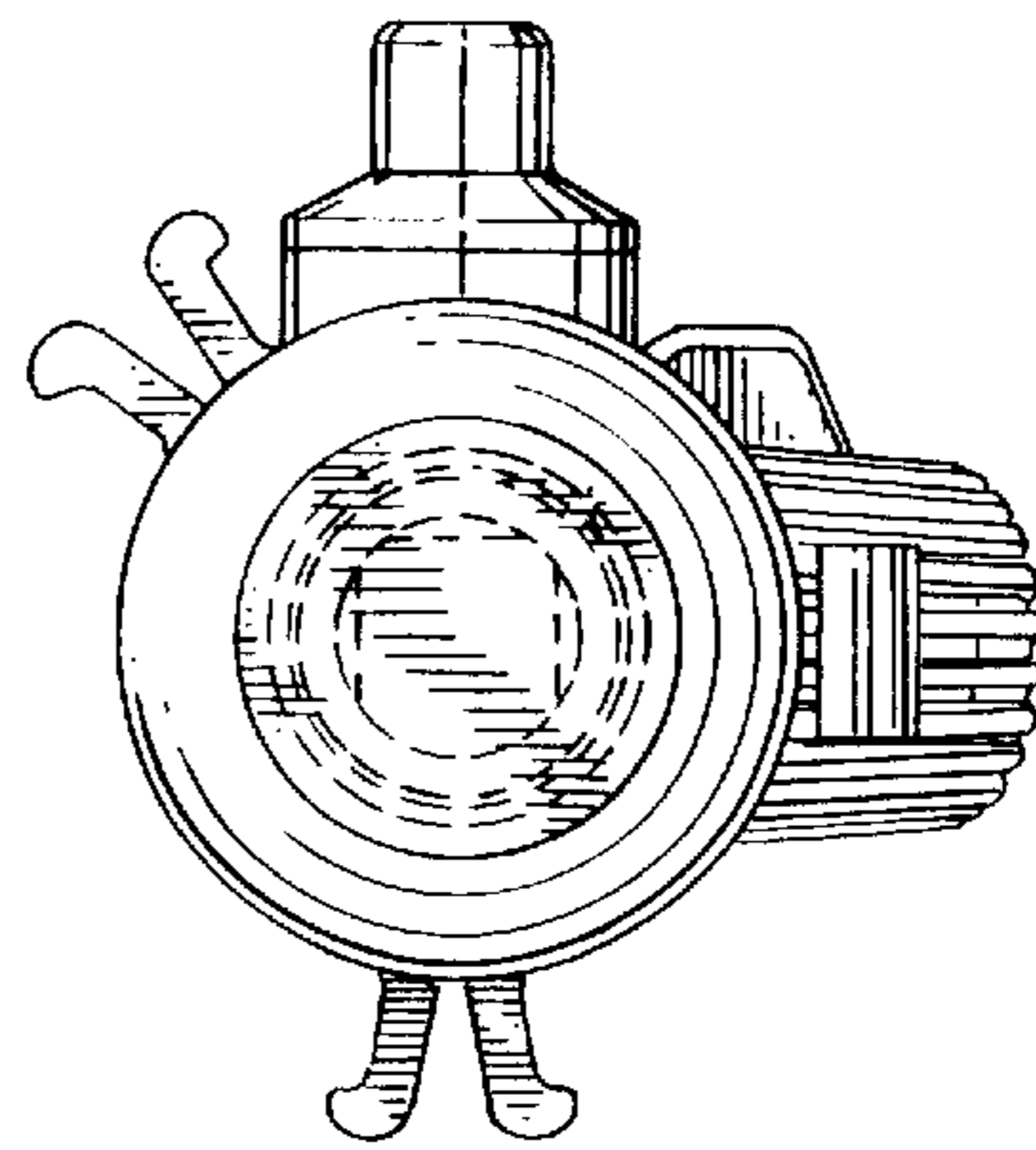

FIG. 5

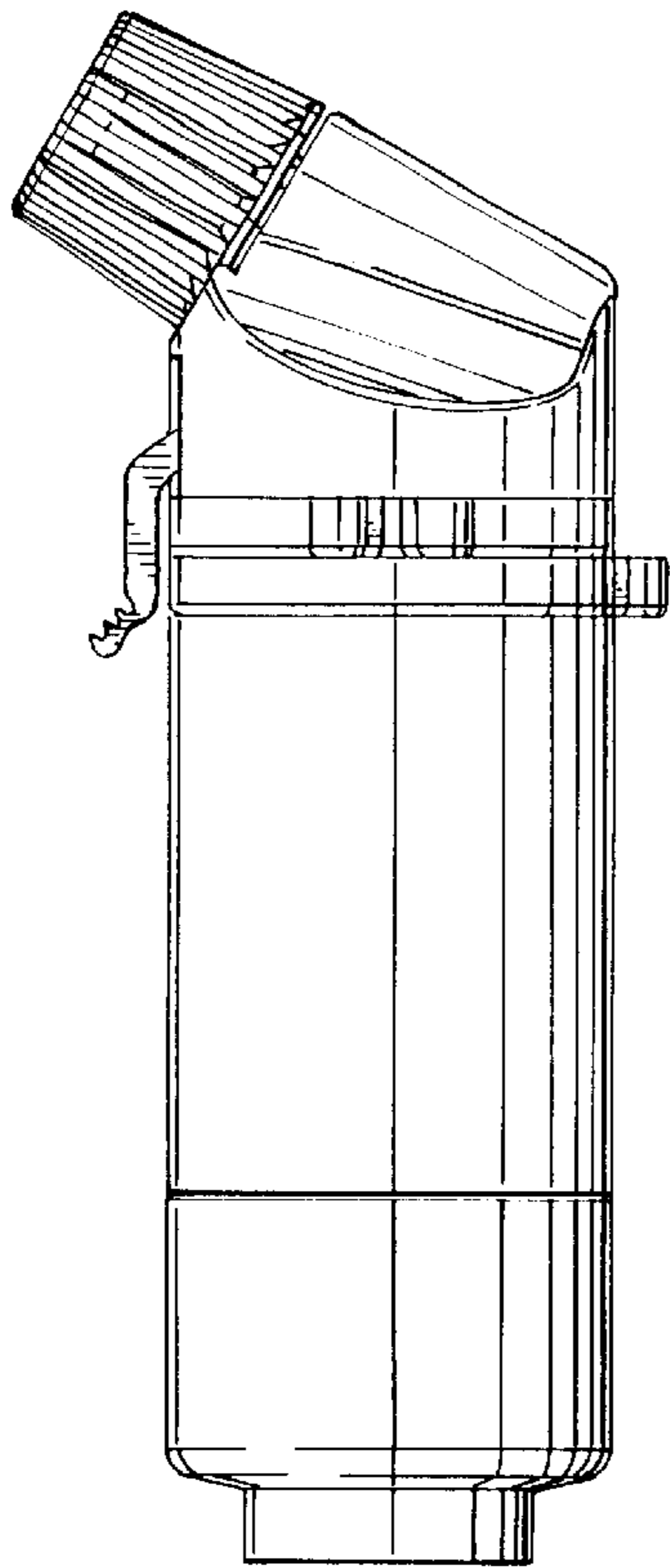

FIG. 6

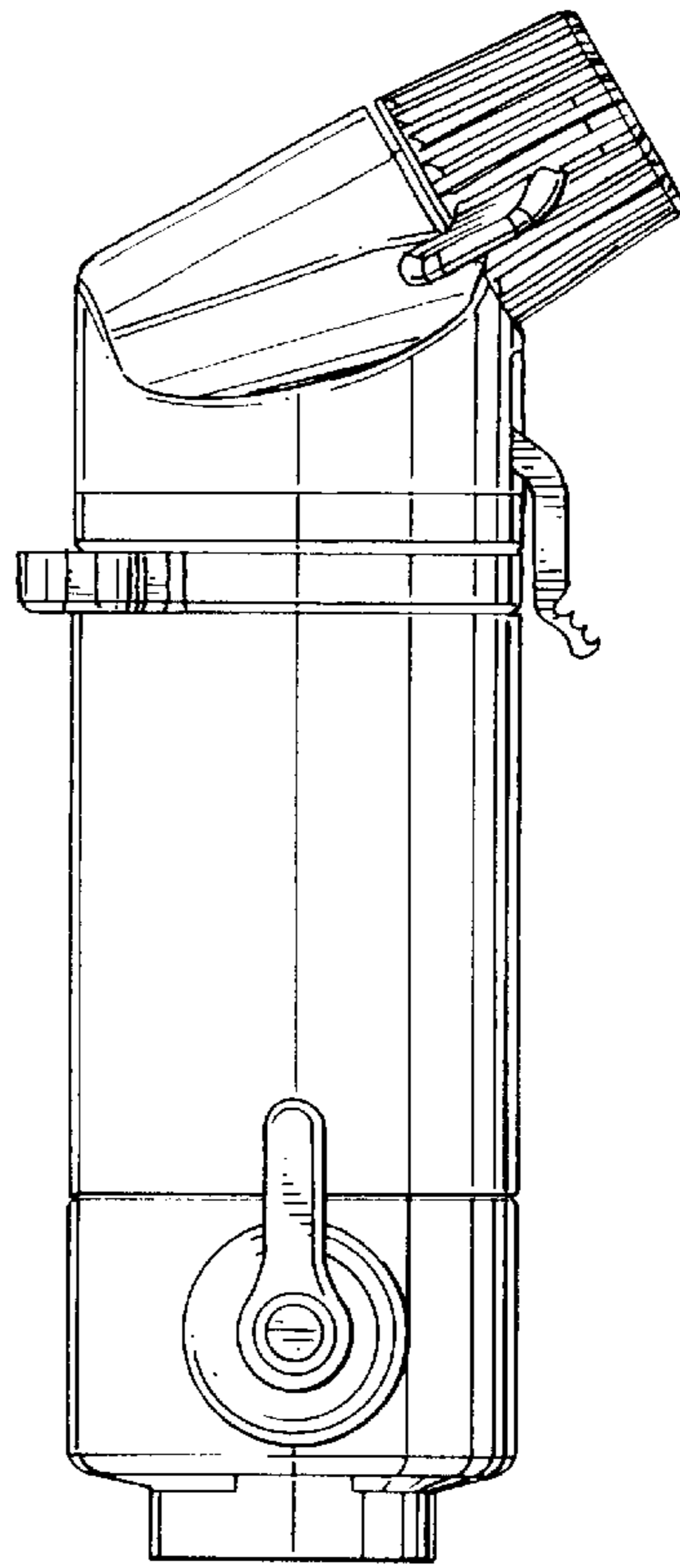

FIG. 7

