



US00D444786S

(12) **United States Design Patent**
Otomi et al.

(10) **Patent No.:** **US D444,786 S**

(45) **Date of Patent:** **** Jul. 10, 2001**

(54) **OPERATING APPARATUS FOR GAME MACHINE**

(75) Inventors: **Makiko Otomi**, Musashino; **Eiji Yokoi**; **Masatoshi Mukai**, both of Kobe, all of (JP)

(73) Assignee: **Konami Co., Ltd.**, Tokyo (JP)

(**) Term: **14 Years**

(21) Appl. No.: **29/125,251**

(22) Filed: **Jun. 20, 2000**

(30) **Foreign Application Priority Data**

Dec. 24, 1999 (JP) 11-35815

(51) **LOC (7) Cl.** **21-01**

(52) **U.S. Cl.** **D14/418**

(58) **Field of Search** D14/418, 400, D14/401; D21/324-333; 273/148 B, 574, 348, 349, 317; 463/30-35, 46, 47, 1, 5, 50, 51, 52

(56) **References Cited**

U.S. PATENT DOCUMENTS

D. 386,543 * 11/1997 Chikui et al. D14/418

D. 416,013 * 11/1999 Muraki et al. D14/418
D. 436,356 * 1/2001 Lee D14/418
3,655,192 * 4/1972 Hall et al. 463/51
4,175,747 * 11/1979 Hudson 463/49
5,569,085 * 10/1996 Igarashi et al. 463/49

* cited by examiner

Primary Examiner—Prabhakar Deshmukh

(74) *Attorney, Agent, or Firm*—Jordan and Hamburg LLP

(57) **CLAIM**

The ornamental design for an operating apparatus for game machine, as shown and described.

DESCRIPTION

FIG. 1 is a perspective view of an operating apparatus for game machine;
FIG. 2 is a front view thereof;
FIG. 3 is a top view thereof;
FIG. 4 is a bottom view thereof;
FIG. 5 is a rear view thereof;
FIG. 6 is a left side view thereof; and,
FIG. 7 is a right side view thereof.

1 Claim, 3 Drawing Sheets

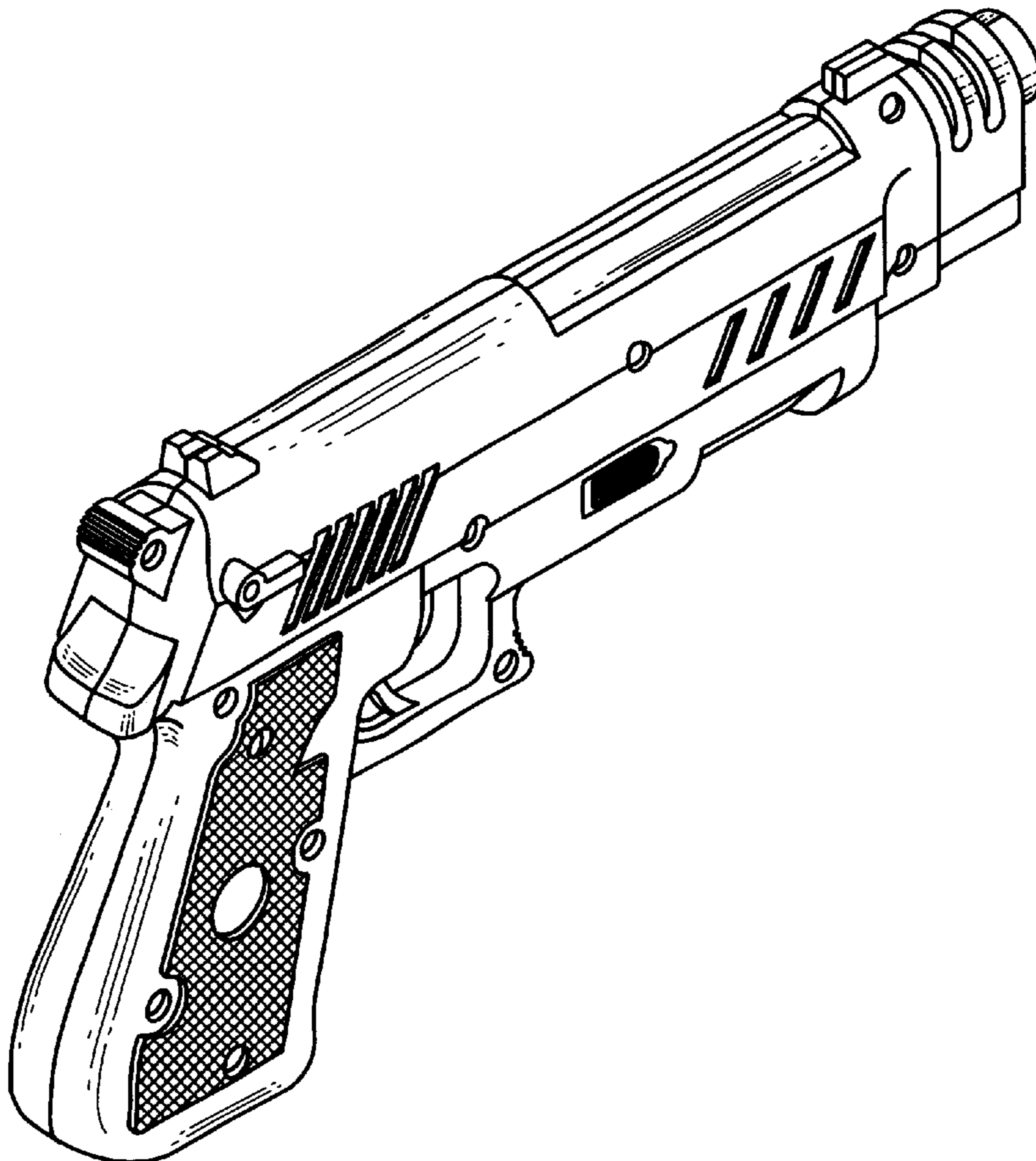

FIG. 1

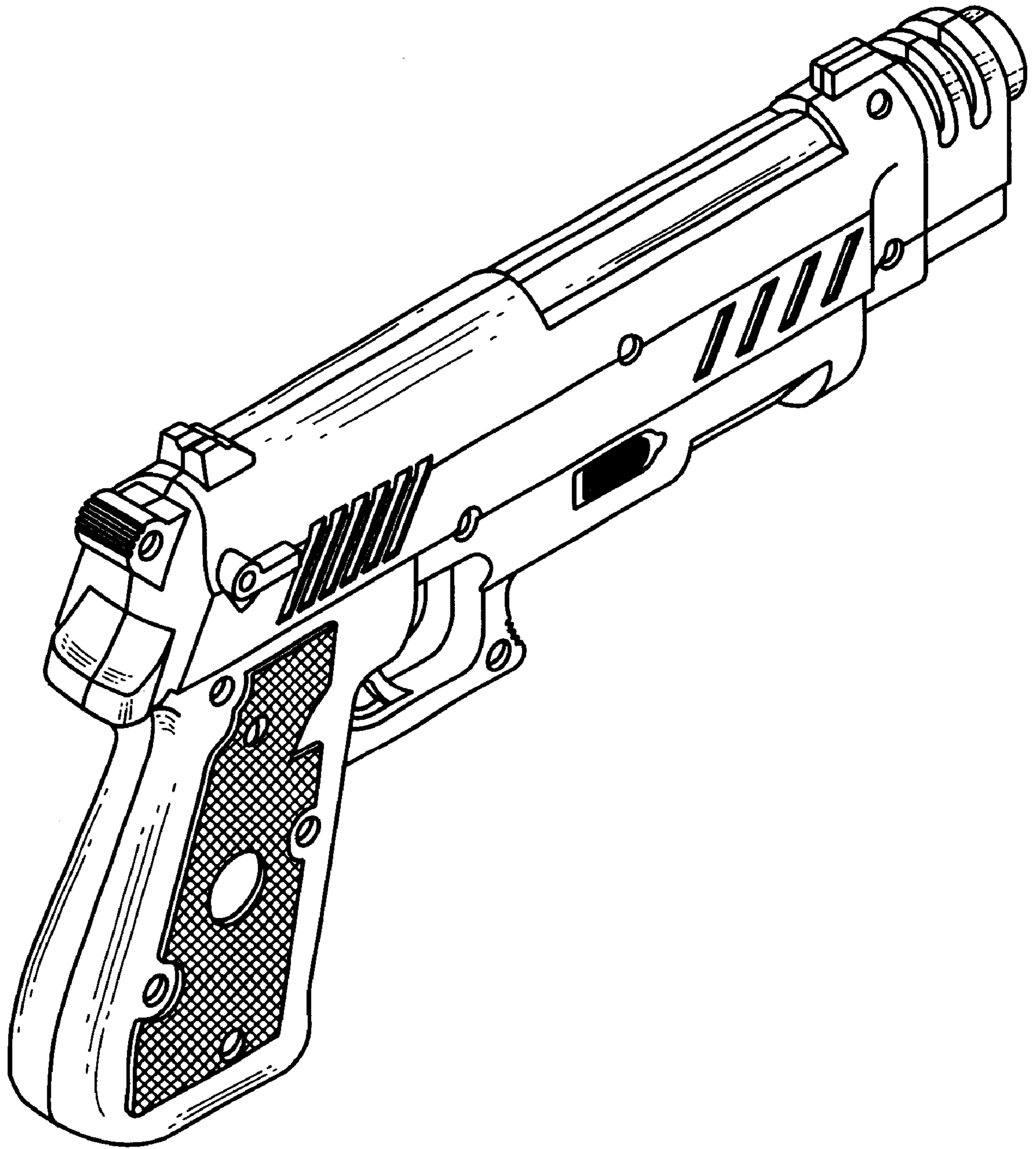

FIG. 3

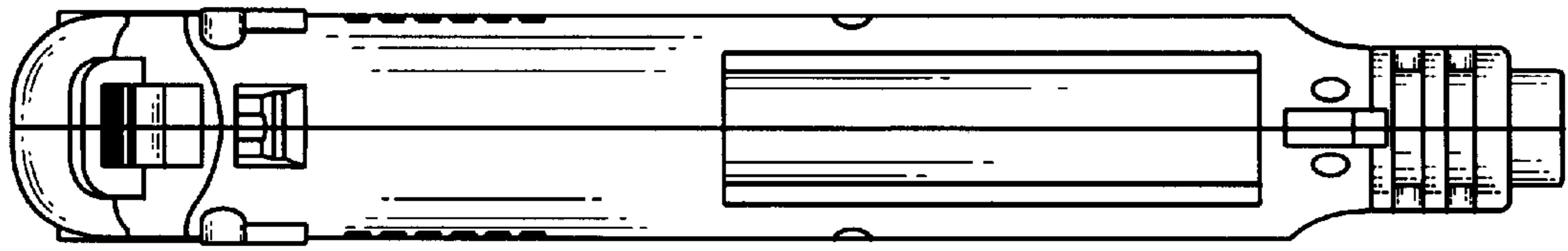

FIG. 2

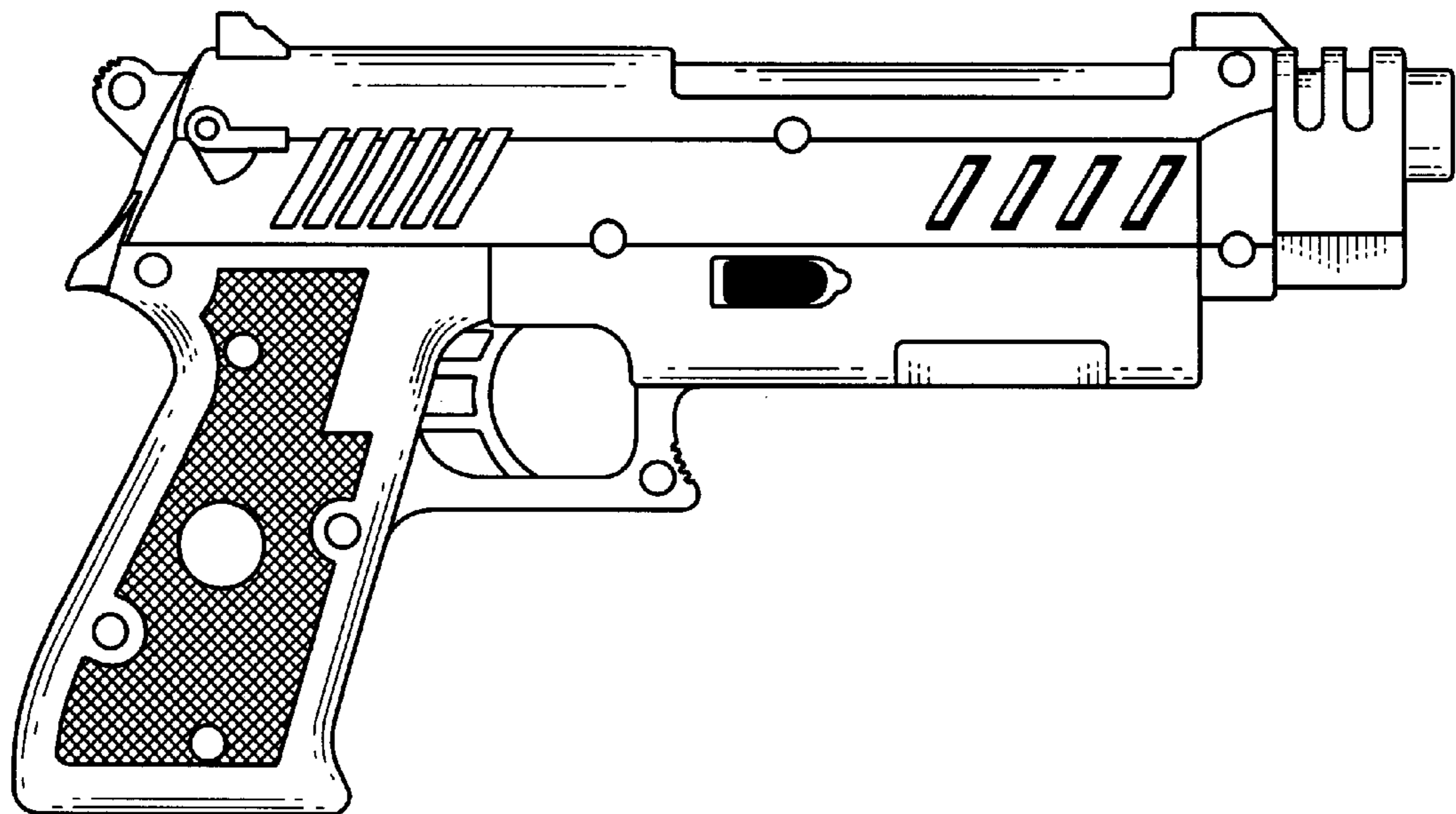

FIG. 4

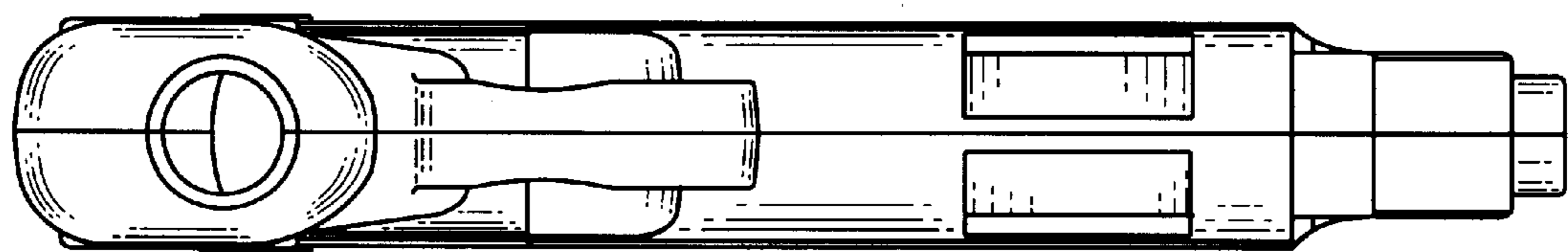

FIG. 5

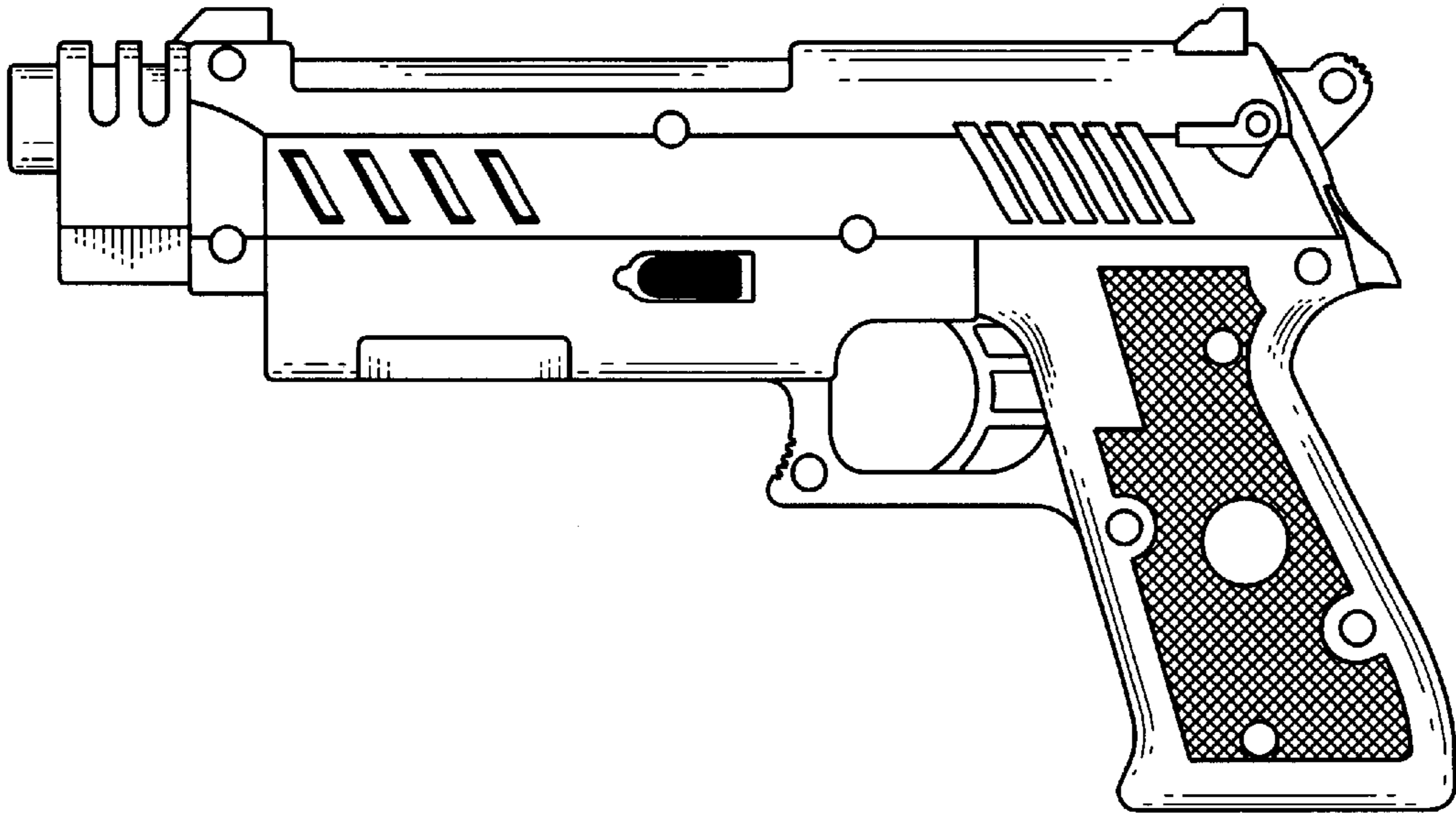

FIG. 6

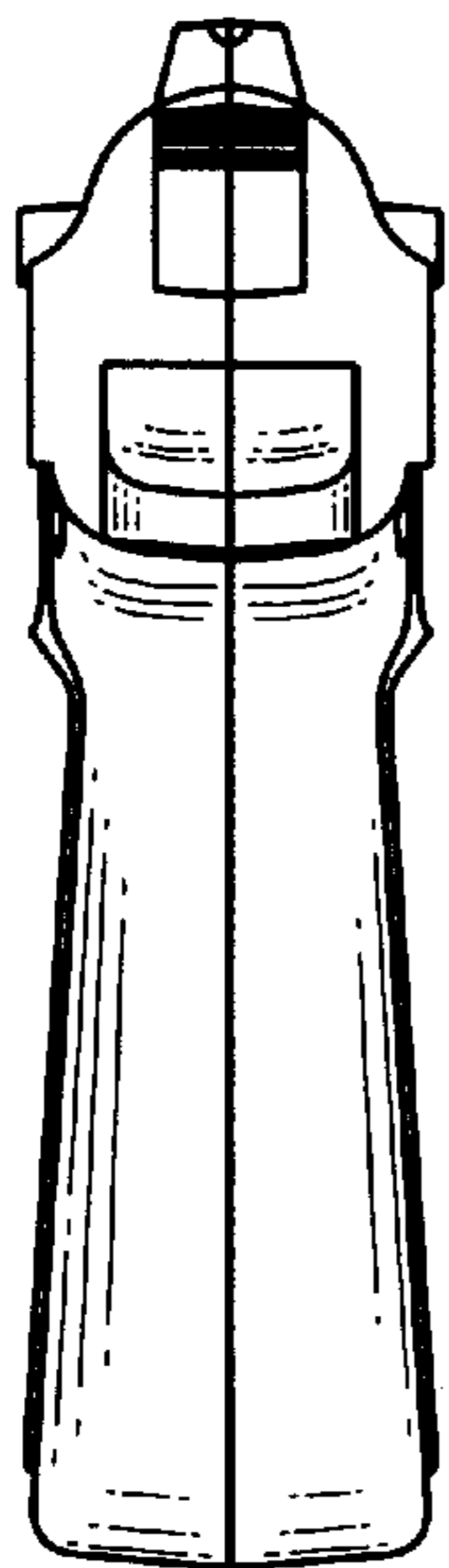

FIG. 7

