



US00D444753S

(12) **United States Design Patent**
Smith et al.

(10) **Patent No.:** **US D444,753 S**

(45) **Date of Patent:** **** Jul. 10, 2001**

(54) **OUTER SURFACE OF A PAIR OF SIDE
PANELS FOR A DUMP TRUCK BODY**

(75) Inventors: **Joseph G. Smith**, Howard; **Richard R.
Lewellen**, Wooster, both of OH (US)

(73) Assignee: **Stahl/Scott Fetzer Company**, Wooster,
OH (US)

(*) Notice: This patent is subject to a terminal dis-
claimer.

(**) Term: **14 Years**

(21) Appl. No.: **29/125,106**

(22) Filed: **Jun. 19, 2000**

Related U.S. Application Data

(63) Continuation-in-part of application No. 29/102,198, filed on
Mar. 19, 1999.

(51) **LOC (7) Cl.** **12-16**

(52) **U.S. Cl.** **D12/196**

(58) **Field of Search** D12/196, 14, 15,
D12/93, 98; 414/476, 477, 480; 298/11,
23 C, 23 M, 30; 296/56, 57.1

(56) **References Cited**

U.S. PATENT DOCUMENTS

- D. 256,901 9/1980 Carr, Jr. et al. .
- D. 301,572 6/1989 McKinnon .
- D. 342,930 1/1994 Lewellen et al. .
- D. 345,123 3/1994 Lewellen et al. .
- D. 346,571 5/1994 Lewellen et al. .
- D. 351,816 10/1994 Lewellen et al. .
- D. 351,817 10/1994 Lewellen et al. .
- D. 386,128 11/1997 Gerding et al. .
- D. 393,234 4/1998 Stragier .

- D. 409,524 5/1999 McKinney .
- D. 412,682 8/1999 Gerding et al. .
- D. 435,499 * 12/2000 Smith et al. D12/196
- 4,306,381 12/1981 Presto .
- 5,239,753 8/1993 Kalis, Jr. et al. .

OTHER PUBLICATIONS

Advertisement for Henderson Manufacturing, Division of
Willknight, Inc., Manchester, Iowa, Entitled "Spreader and
Dump Body Combo Works Year Around", Published on p.
42 of *Government Product News Magazine*, Dec. 1998.
Product Brochure for Stahl Landmaster Dump Bodies,
Stahl/Scott Fetzer, Wooster, Ohio Published, 1995.

* cited by examiner

Primary Examiner—Melody N. Brown

(74) *Attorney, Agent, or Firm*—Watts, Hoffmann, Fisher &
Heinke, Co., L.P.A.

(57) **CLAIM**

The ornamental design for an outer surface of a pair of side
panels for a dump truck body, as shown and described.

DESCRIPTION

FIG. 1 is a perspective view of the portion of a pair of side
panels for a dump truck body showing our new design;
FIG. 2 is a side elevation view of the left side panel shown
in FIG. 1;
FIG. 3 is a side elevation view of the right side panel;
FIG. 4 is a top plan view of the left side panel;
FIG. 5 is a bottom plan view of the left side panel; and,
FIG. 6 is a greatly enlarged cross-sectional view of the left
side panel as seen from the plane indicated by the line 6—6
in FIG. 2, the right side panel being a mirror image thereof.
The broken lines shown are for illustrative purposes only
and form no part of the claimed design.

1 Claim, 3 Drawing Sheets

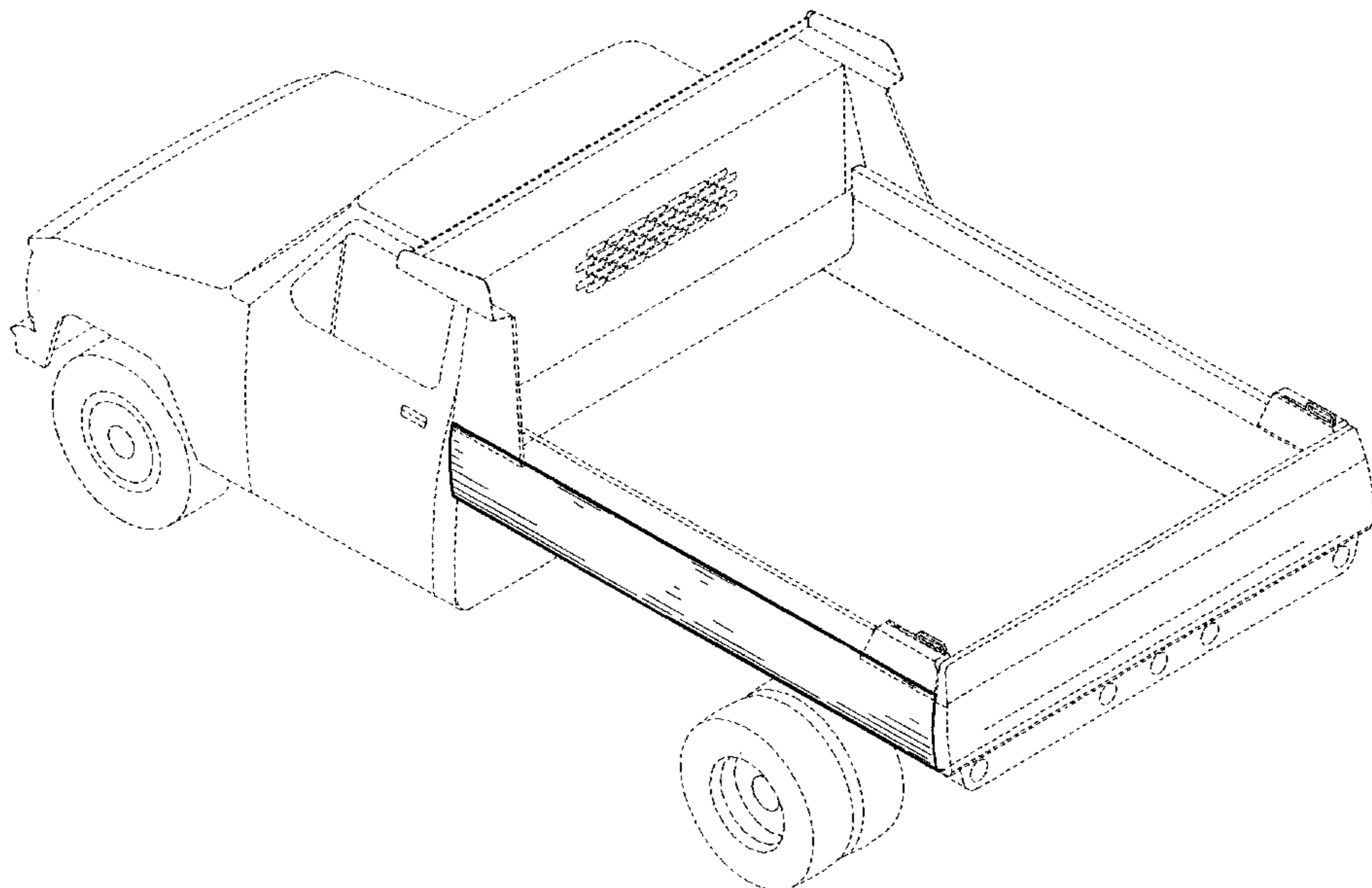

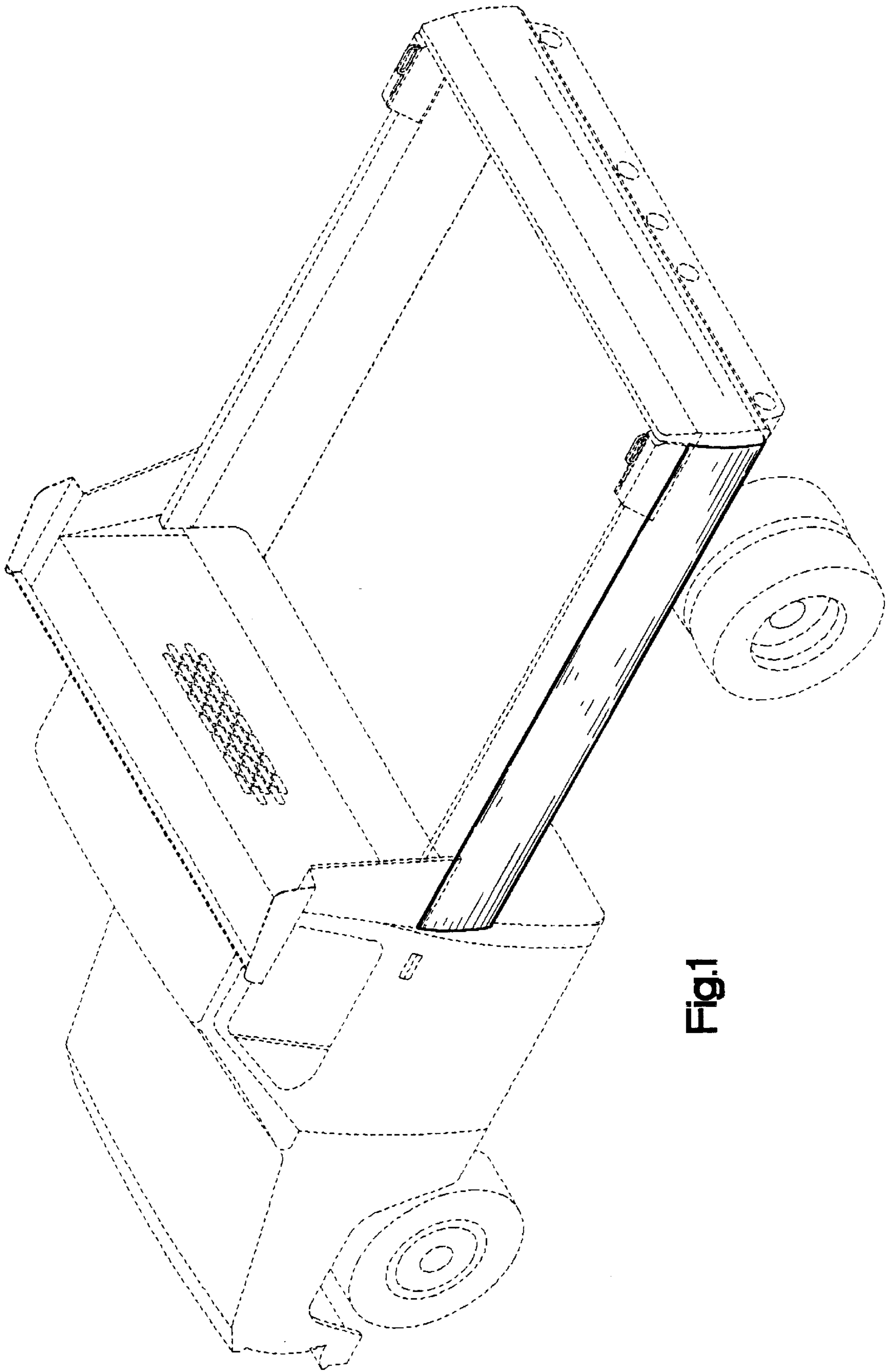

Fig.1

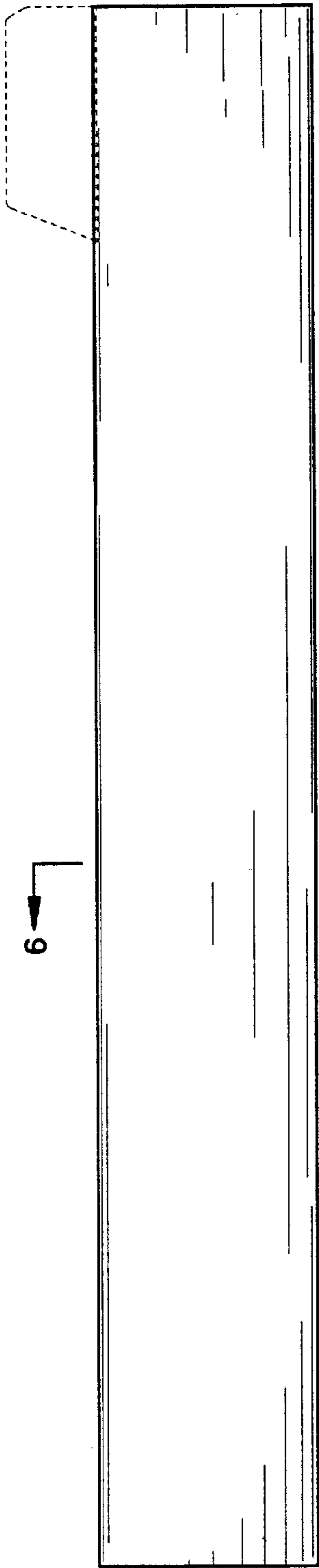

Fig. 2

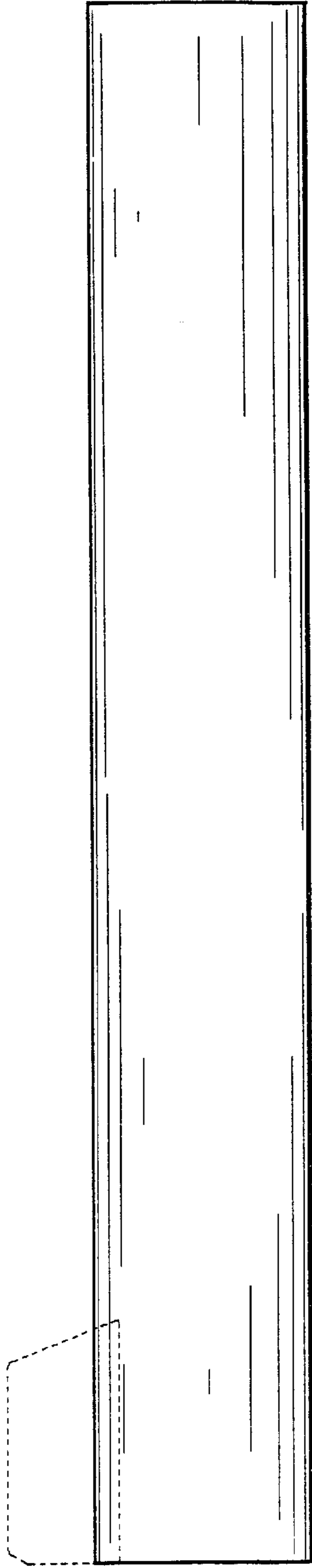

Fig. 3

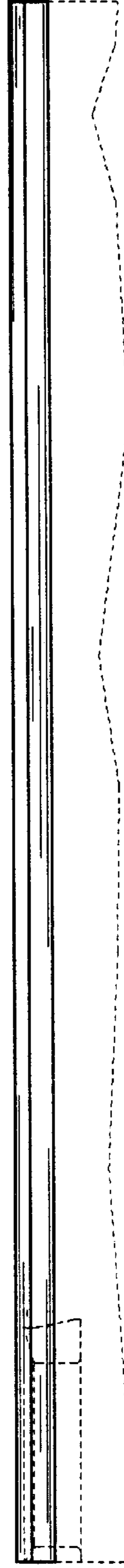

Fig. 4

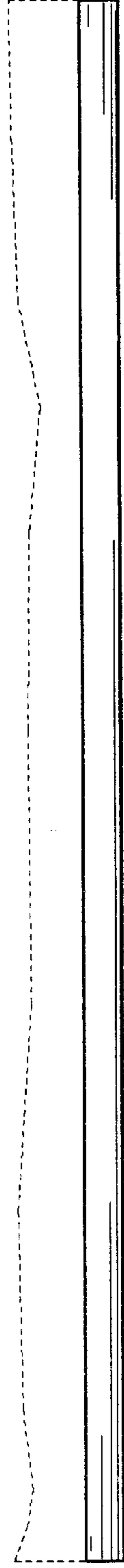

Fig. 5

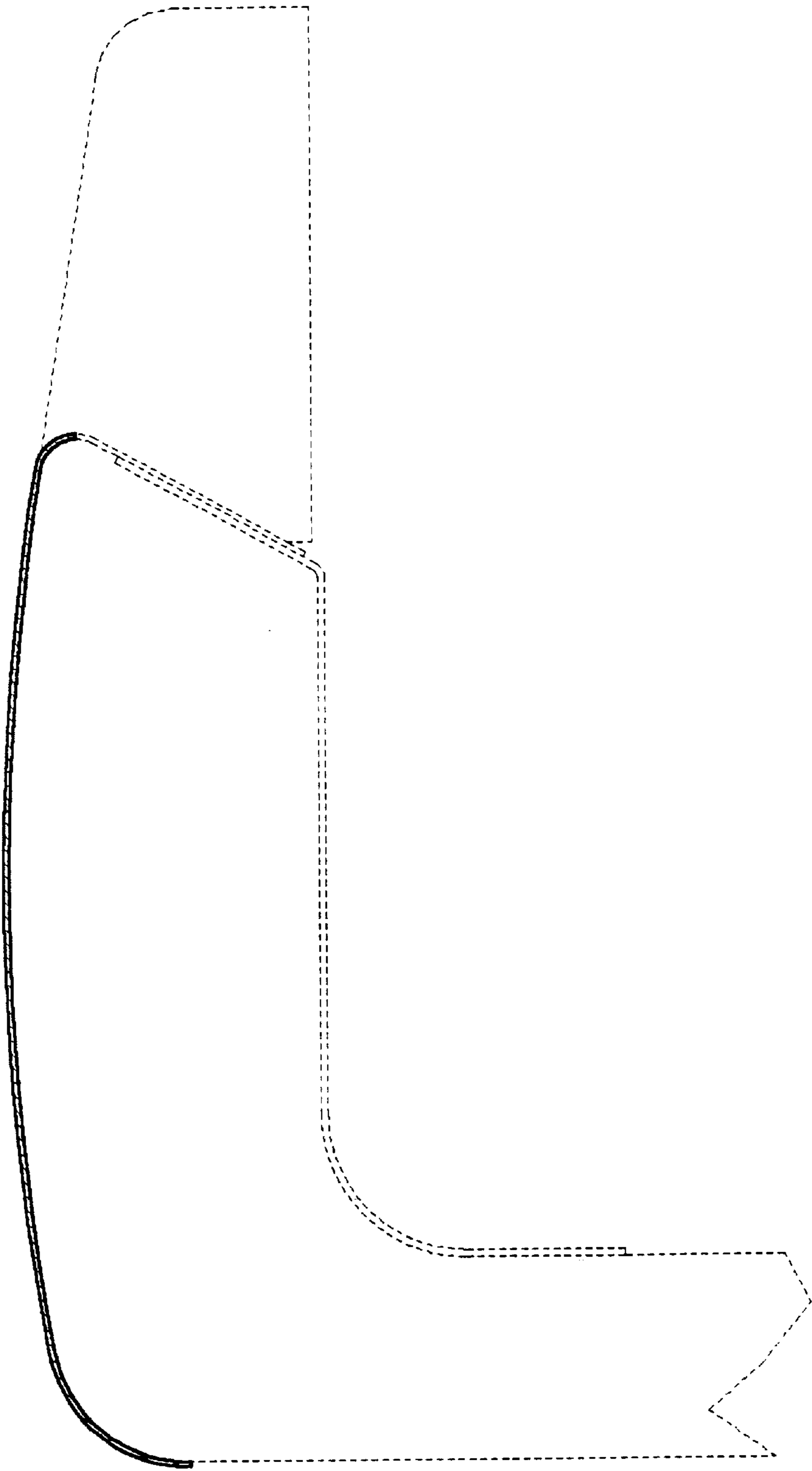

Fig.6