



US00D444747S

(12) **United States Design Patent**  
**Pfeiffer**

(10) **Patent No.:** **US D444,747 S**

(45) **Date of Patent:** **\*\* Jul. 10, 2001**

(54) **HOOD FOR A VEHICLE**

(75) Inventor: **Peter Pfeiffer**, Boeblingen (DE)

(73) Assignee: **DaimlerChrysler AG**, Stuttgart (DE)

(\*\*) Term: **14 Years**

(21) Appl. No.: **29/128,243**

(22) Filed: **Aug. 22, 2000**

**Related U.S. Application Data**

(62) Division of application No. 29/086,743, filed on Apr. 20, 1998, now Pat. No. Des. 433,653.

(30) **Foreign Application Priority Data**

Feb. 28, 2000 (DE) ..... 4 00 02 024

(51) **LOC (7) Cl.** ..... **12-16**

(52) **U.S. Cl.** ..... **D12/173**

(58) **Field of Search** ..... D12/173, 90-92;  
180/69.21, 69.2, 69.22, 69.25

(56) **References Cited**

**U.S. PATENT DOCUMENTS**

- D. 368,448 \* 4/1996 Sacco et al. .... D12/92
- D. 372,689 \* 8/1996 Sacco et al. .... D12/92
- D. 380,178 \* 6/1997 Sacco et al. .... D12/92
- D. 391,540 \* 3/1998 Horbury ..... D12/173
- D. 393,440 4/1998 Pfeiffer et al. .... D12/196
- D. 393,610 4/1998 Sacco et al. .... D12/92
- D. 395,847 \* 7/1998 Sacco et al. .... D12/92

- D. 396,432 \* 7/1998 Syring ..... D12/91
- D. 412,145 \* 7/1999 Bangle ..... D12/173
- D. 416,524 \* 11/1999 Gabath ..... D12/173
- D. 419,933 \* 2/2000 Sacco et al. .... D12/173
- D. 422,252 \* 4/2000 Sacco et al. .... D12/173
- D. 428,369 \* 7/2000 Sacco et al. .... D12/173

\* cited by examiner

*Primary Examiner*—Melody N. Brown

(74) *Attorney, Agent, or Firm*—Evenson, McKeown, Edwards & Lenahan, P.L.L.C.

(57) **CLAIM**

The ornamental design for a hood for a vehicle, as shown and described.

**DESCRIPTION**

FIG. 1 is a front, left perspective view of a hood for a vehicle according to my novel design, the front, right perspective view being mirror symmetrical;

FIG. 2 is a front view of the hood for a vehicle according to my novel design;

FIG. 3 is left side view of the hood for a vehicle according to my novel design;

FIG. 4 is a right side view of the hood for a vehicle according to my novel design; and,

FIG. 5 is rear view of the hood for a vehicle according to my novel design.

The broken lines included depict environment and are not part of the claimed design.

**1 Claim, 2 Drawing Sheets**

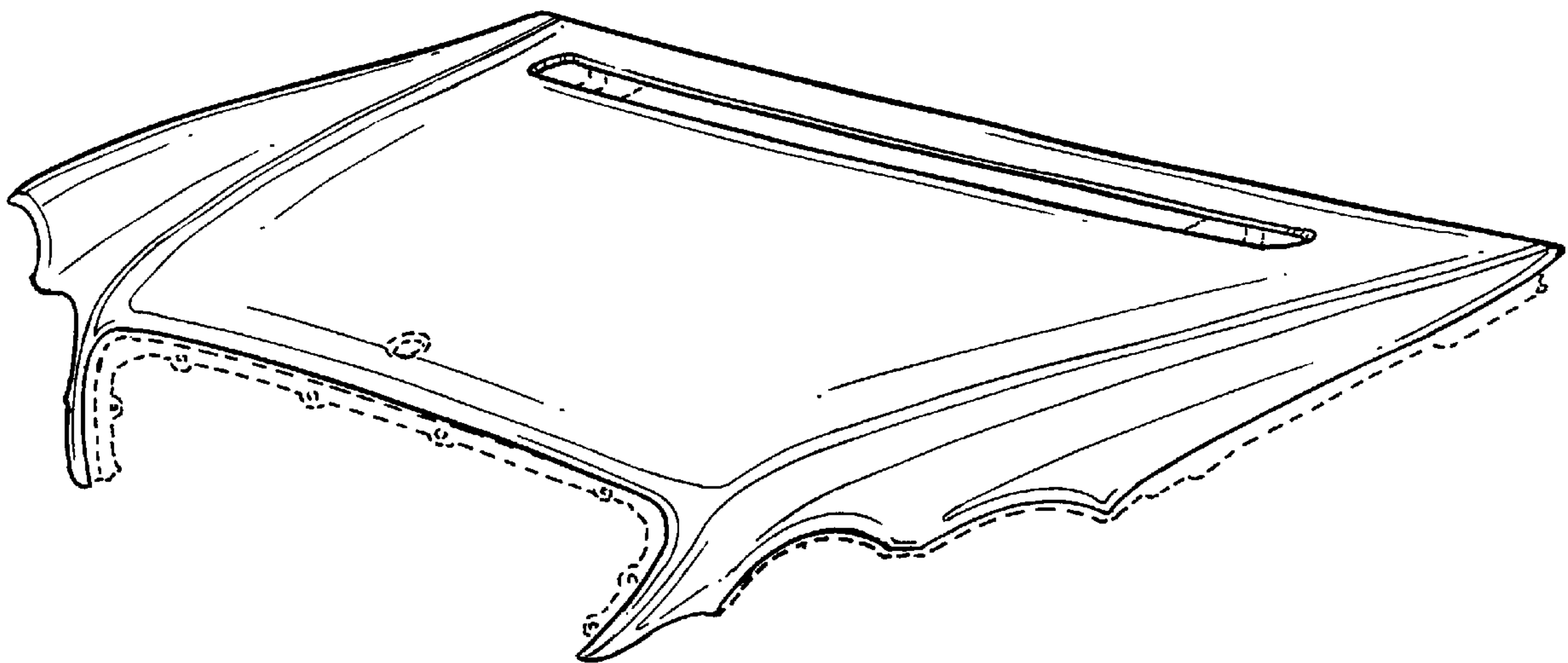

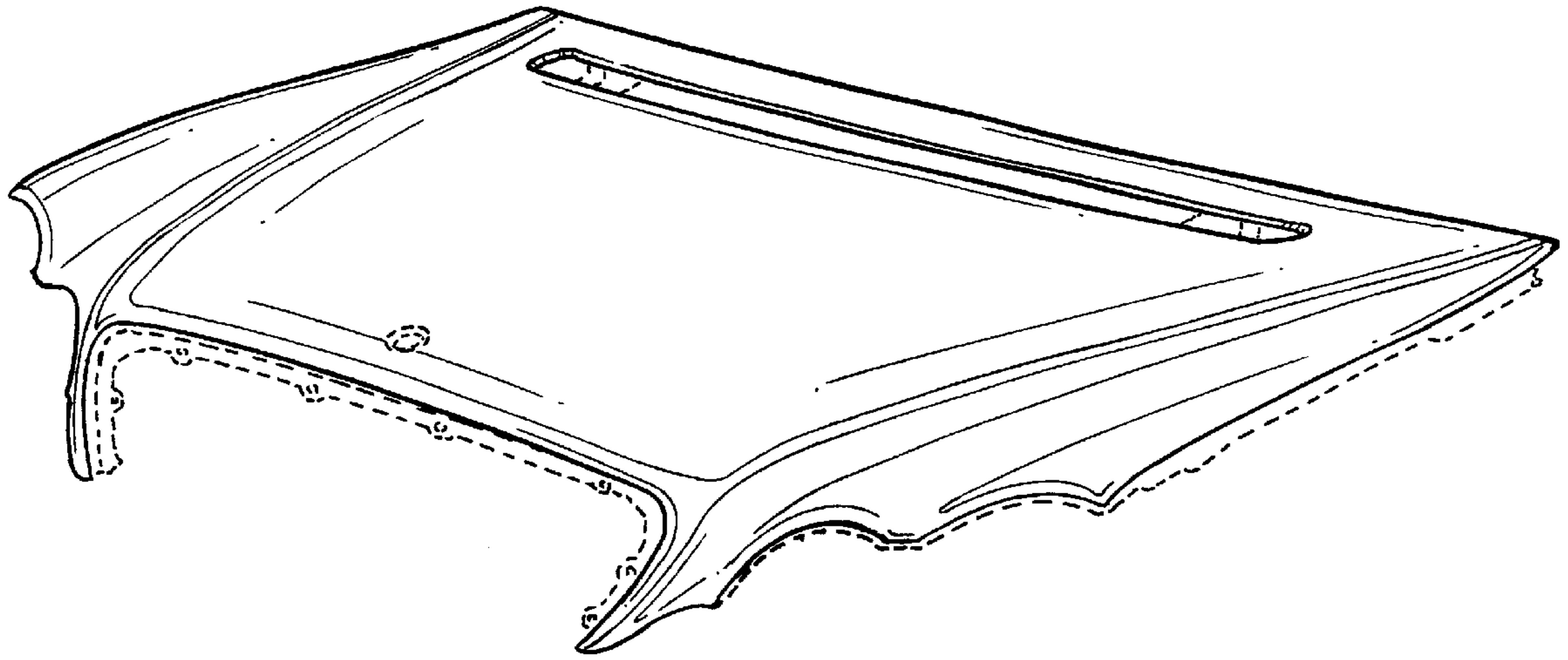

FIG. 1

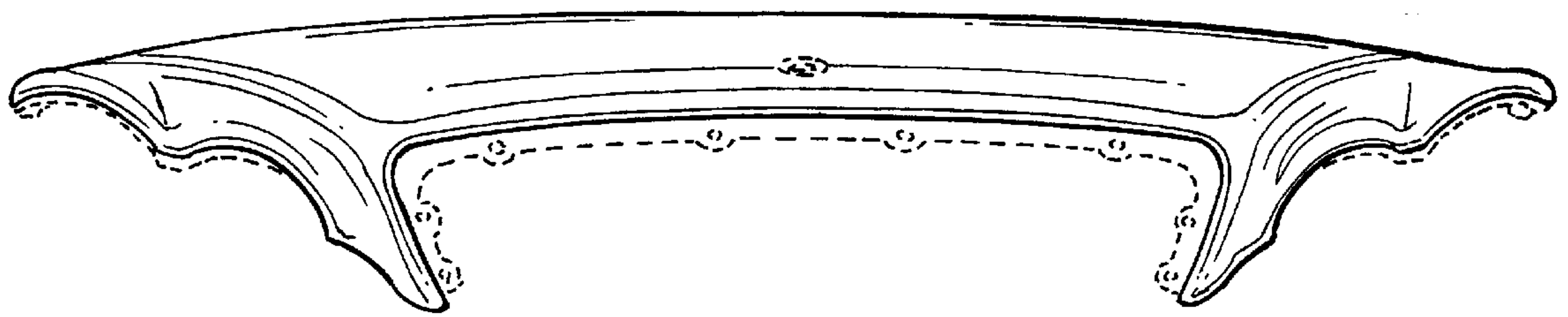

FIG. 2

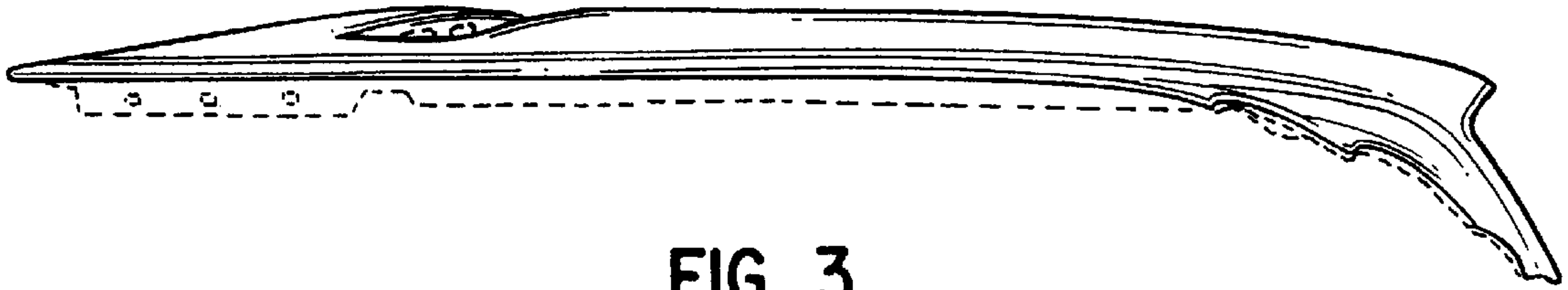

FIG. 3

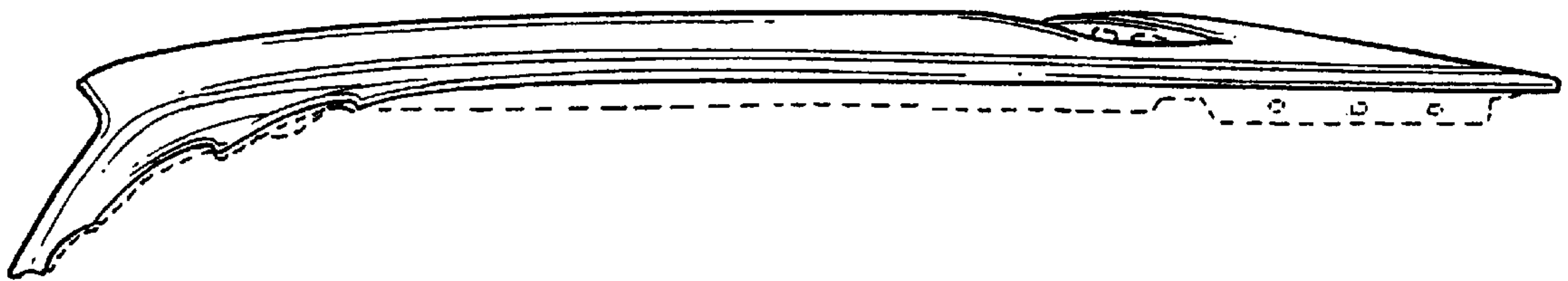

FIG. 4

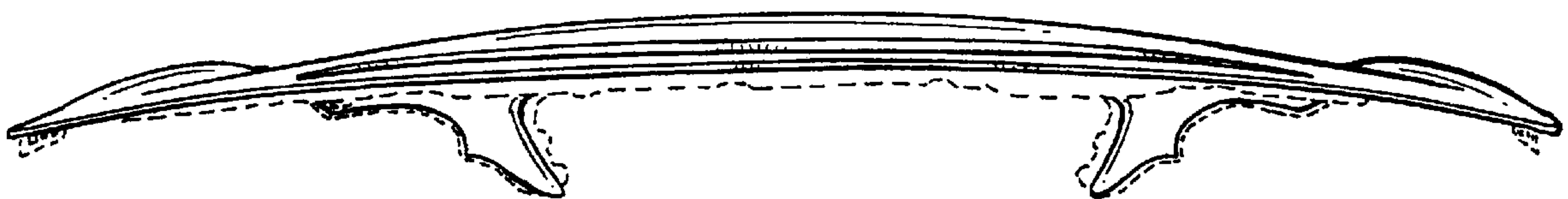

FIG. 5