



US00D444737S

(12) **United States Design Patent**
Allendorph et al.

(10) **Patent No.:** **US D444,737 S**

(45) **Date of Patent:** **** Jul. 10, 2001**

(54) **CAB FOR A TRUCK VEHICLE**

(75) **Inventors:** **L. David Allendorph; Santiago C. Abalos; Franz Mueller**, all of Fort Wayne; **Robert M. Zimmerman**, Kendallville; **Larry N. Reynard**, Fort Wayne, all of IN (US)

D. 391,908 3/1998 Allendorph et al. .
D. 394,624 5/1998 Allendorph et al. .
D. 401,198 11/1998 Mueller et al. .
D. 403,285 12/1998 Abalos et al. .
D. 403,620 1/1999 Abalos et al. .
D. 403,637 1/1999 Abalos et al. .
D. 411,816 * 7/1999 Reynar et al. D12/96
D. 421,412 * 3/2000 Sutton et al. D12/96

(73) **Assignee:** **International Truck and Engine Corporation**, Chicago, IL (US)

* cited by examiner

(**) **Term:** **14 Years**

Primary Examiner—Melody N. Brown

(74) *Attorney, Agent, or Firm*—Jeffrey P. Calfa; Dennis Kelly Sullivan; Gilberto Hernandez

(21) **Appl. No.:** **29/130,659**

(57) **CLAIM**

(22) **Filed:** **Oct. 5, 2000**

The ornamental design for a cab for a truck vehicle, as shown and described.

(51) **LOC (7) Cl.** **12-08**

DESCRIPTION

(52) **U.S. Cl.** **D12/96**

(58) **Field of Search** D12/96, 93, 97,
D12/173, 196; 180/69.2, 89.12, 89.14, 89.16;
296/27, 190

FIG. 1 is a left, front perspective view of a cab of a truck vehicle showing my new design; it may be understood that the broken lines on all figures are for illustrative purposes only and form no part of the claimed design;
FIG. 2 is a right side view of the invention shown in FIG. 1;
FIG. 3 is a left side view of the invention shown in FIG. 1;
FIG. 4 is a back view of the invention shown in FIG. 1;
FIG. 5 is a front view of the invention shown in FIG. 1; and
FIG. 6 is a top view of the invention shown in FIG. 1.

(56) **References Cited**

U.S. PATENT DOCUMENTS

D. 306,421 3/1990 Allendorph et al. .
D. 306,714 3/1990 Allendorph .
D. 307,126 4/1990 Allendorph et al. .
D. 328,273 7/1992 McGrew, Jr. et al. .
D. 335,272 5/1993 Allendorph et al. .

1 Claim, 3 Drawing Sheets

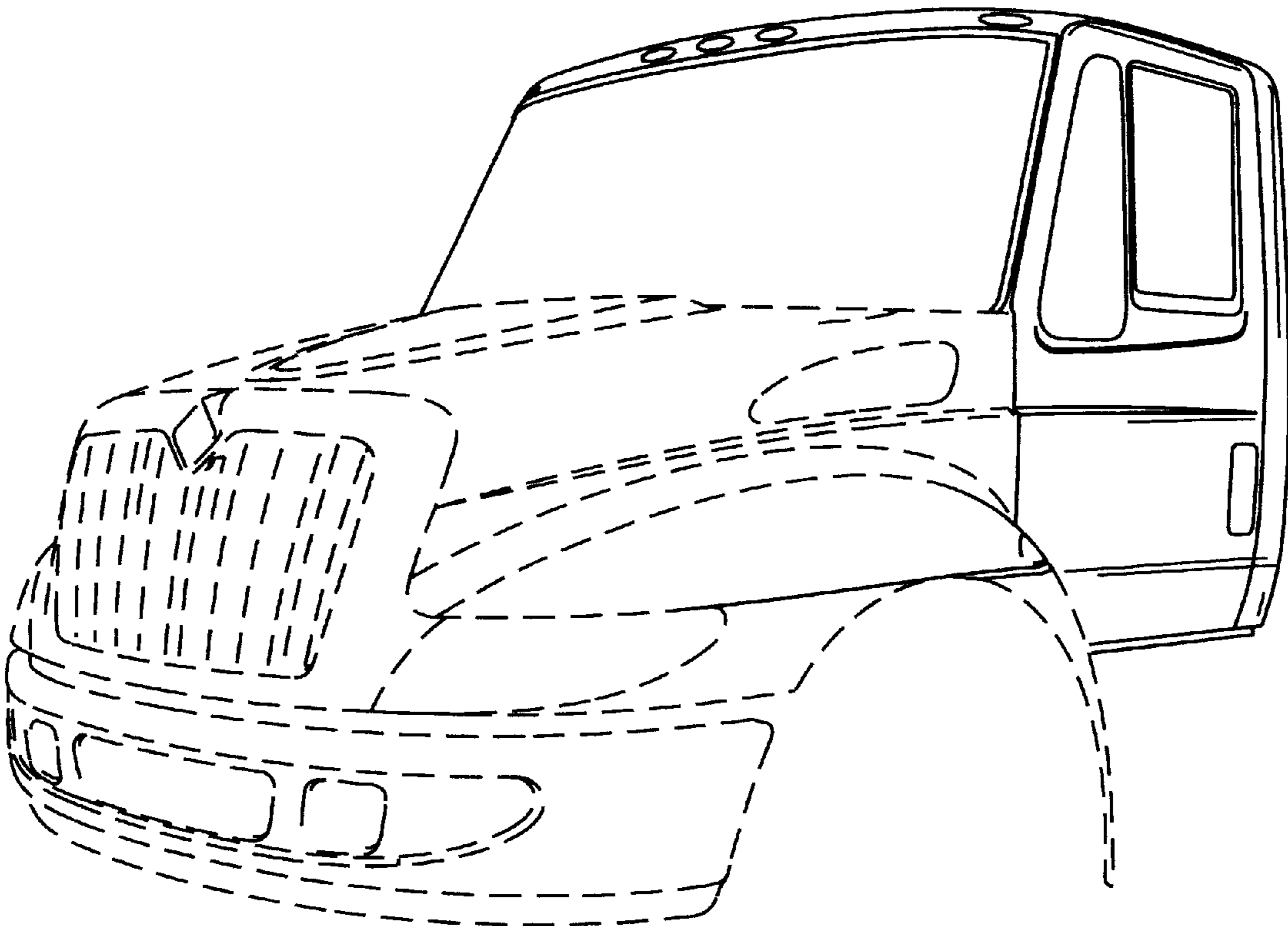

Fig. 1

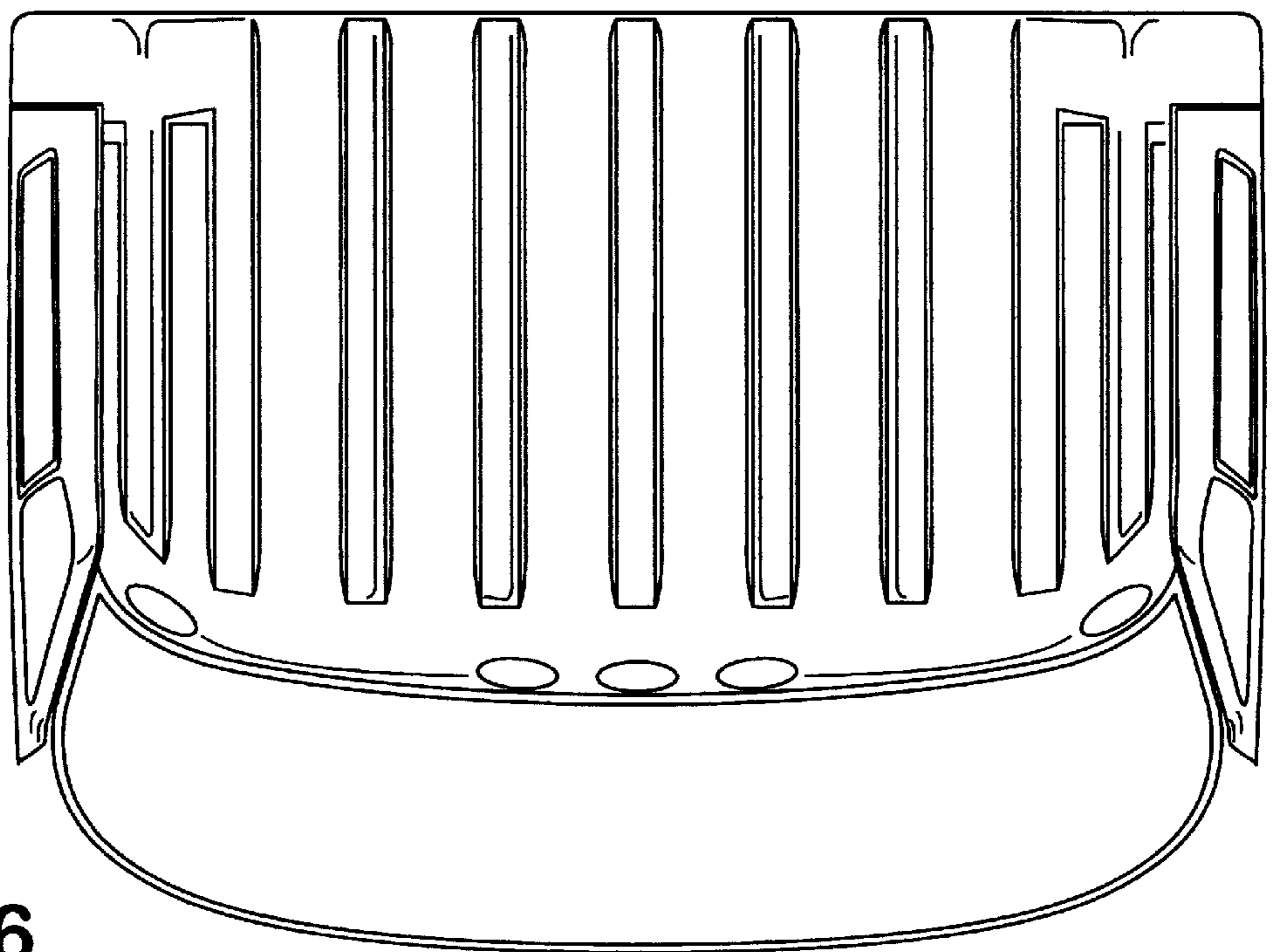
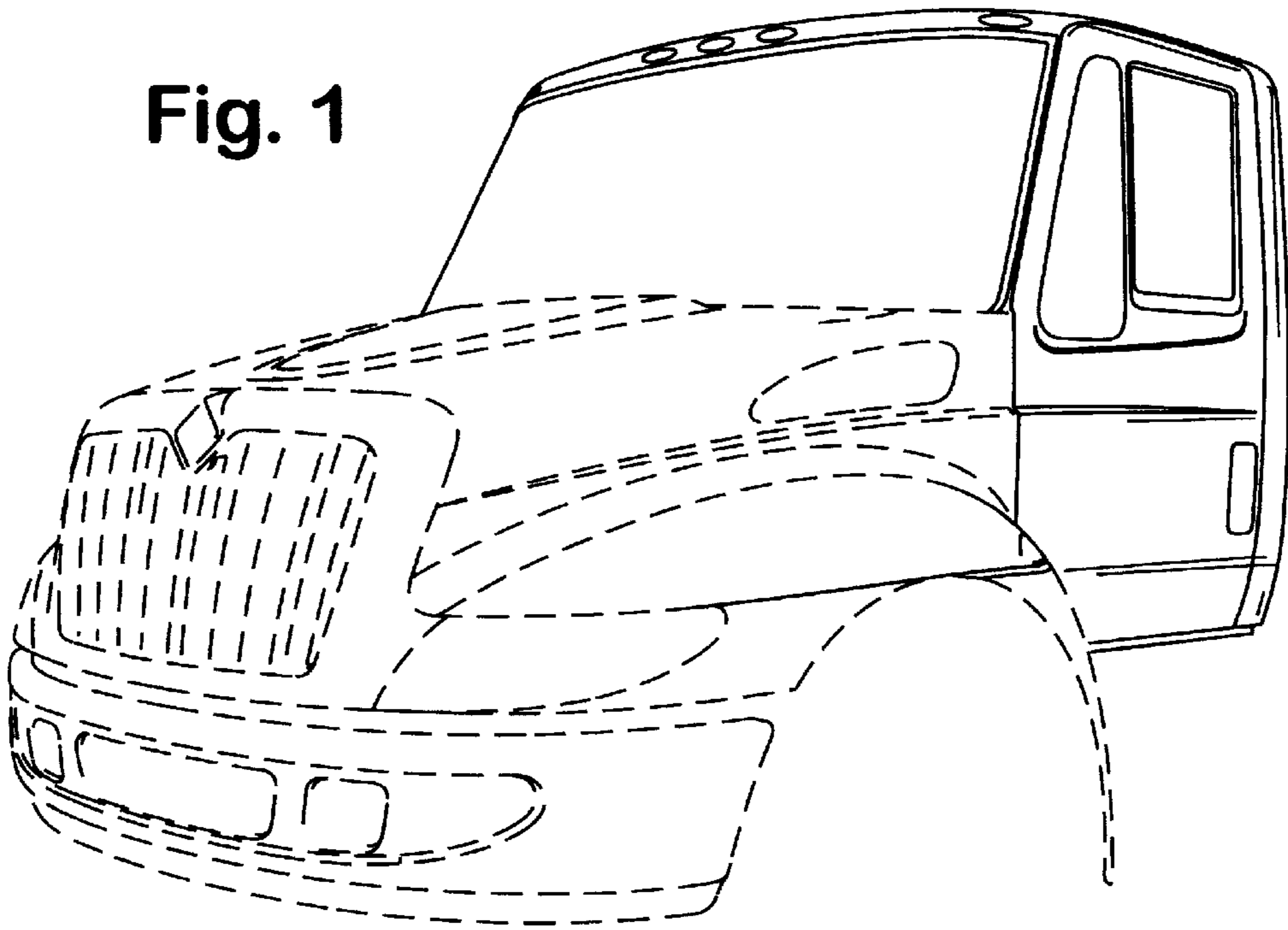

Fig. 6

Fig. 2

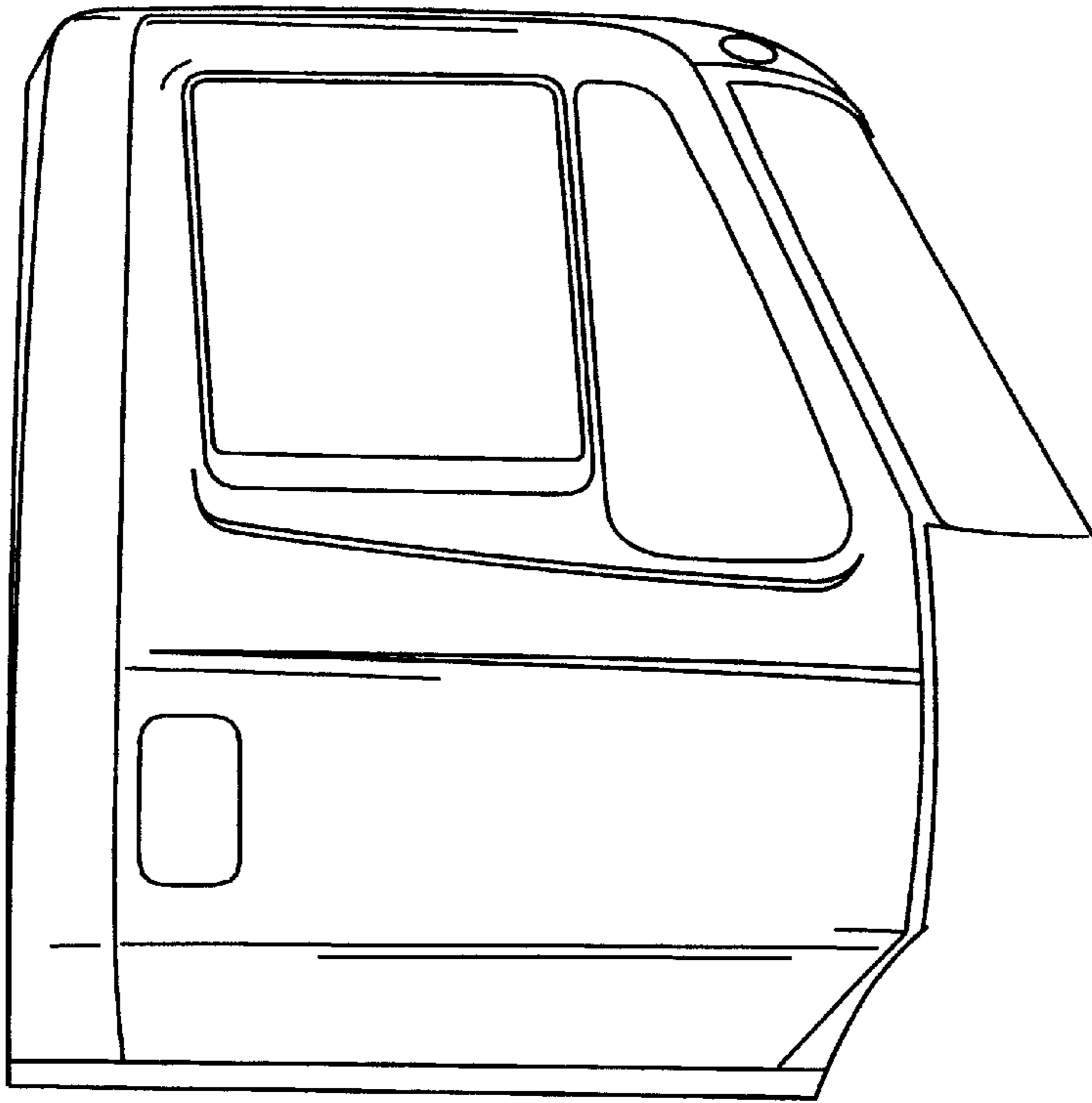
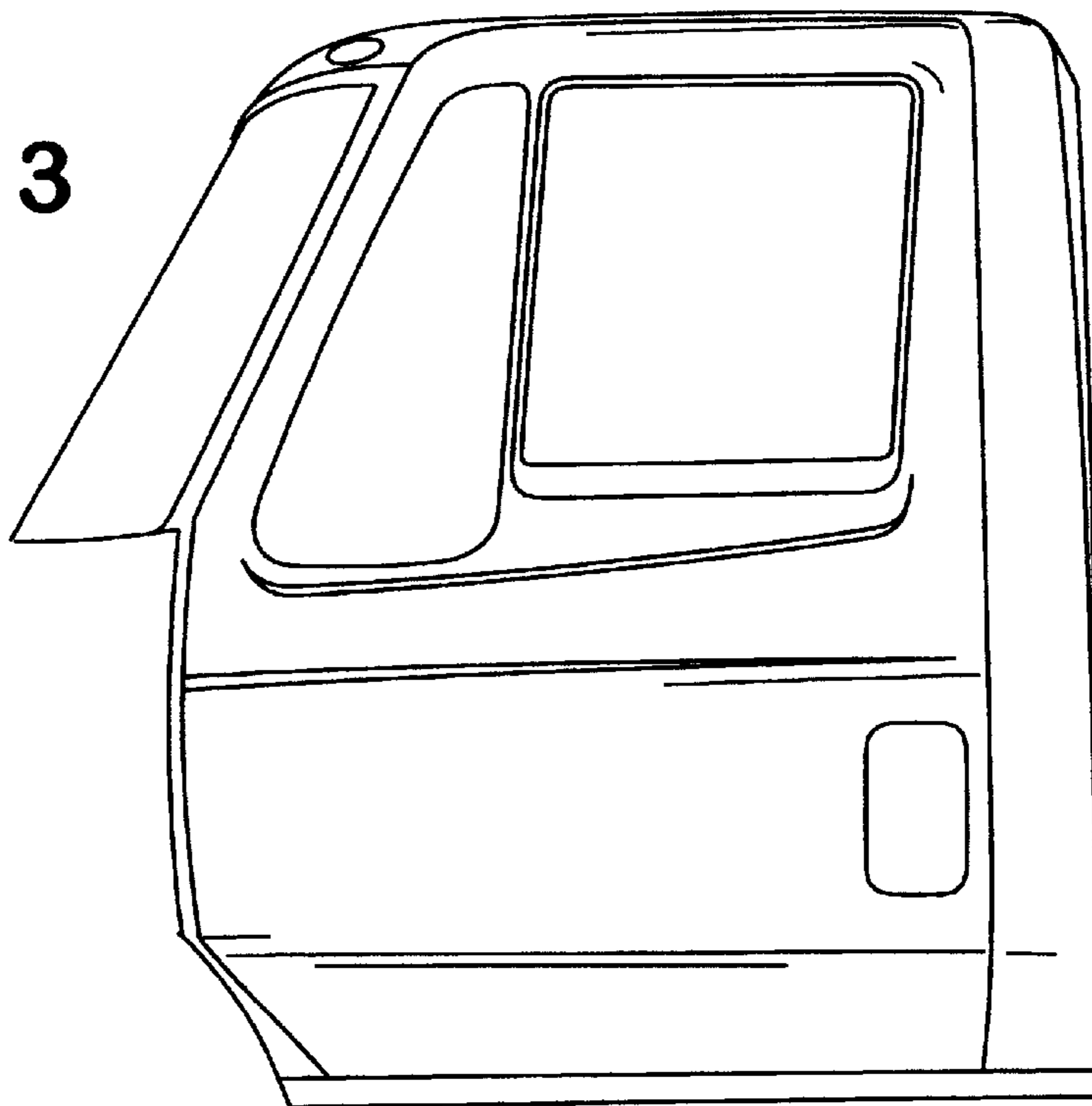

Fig. 3



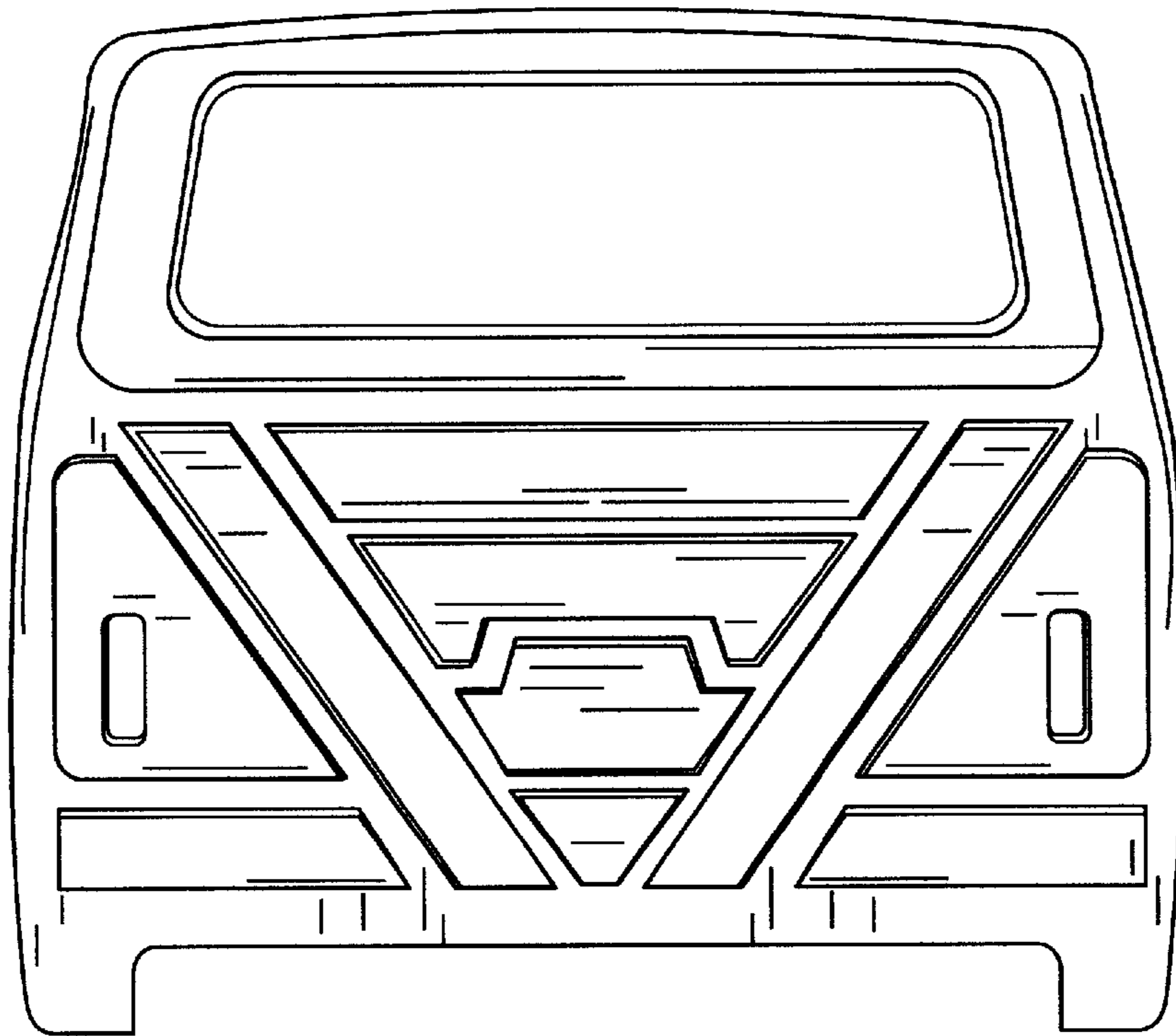

Fig. 4

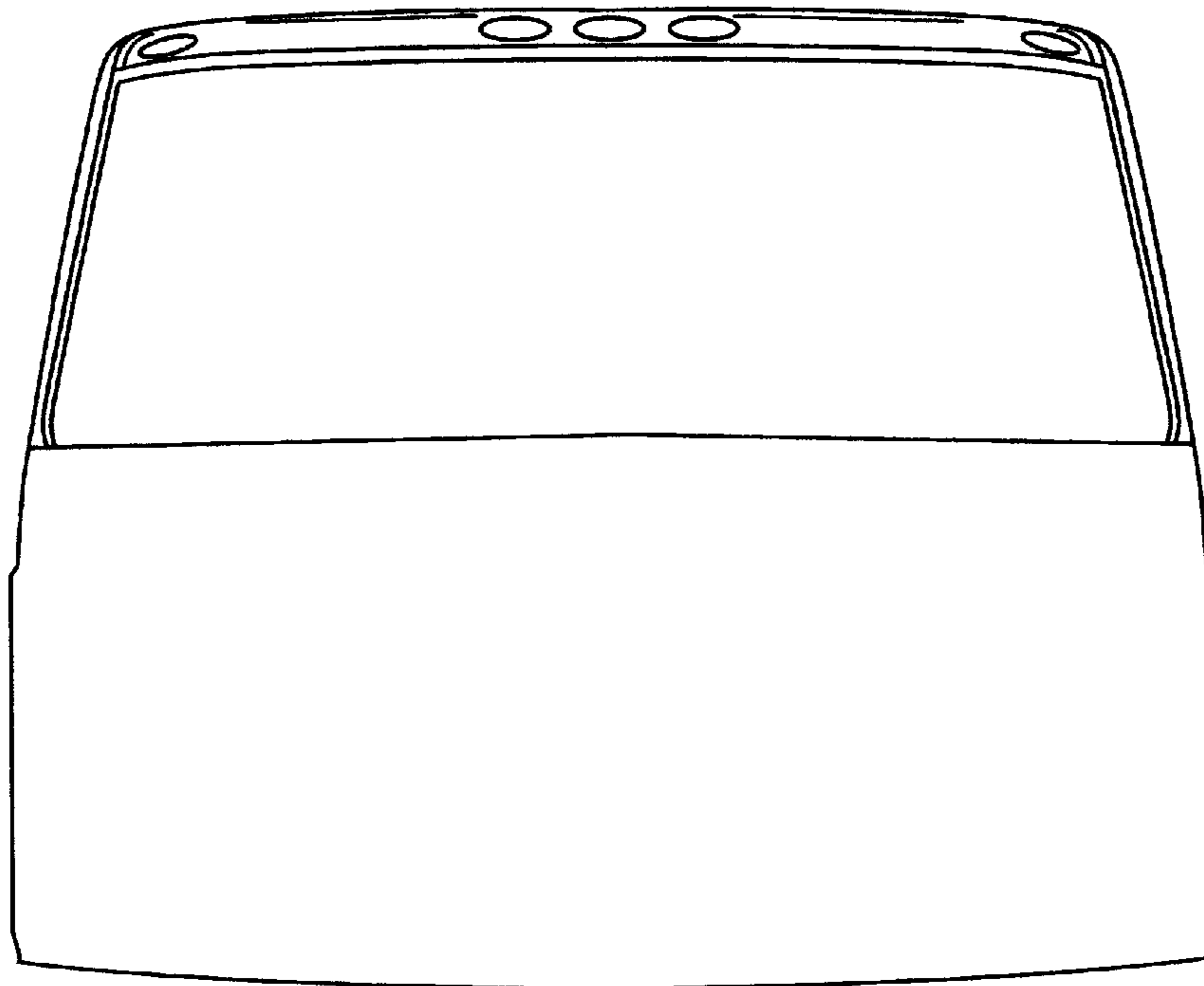

Fig. 5