



US00D444084S

(12) **United States Design Patent**
Wrisley et al.

(10) **Patent No.: US D444,084 S**

(45) **Date of Patent: ** *Jun. 26, 2001**

(54) **MODULAR MEASUREMENT INSTRUMENT**

(75) Inventors: **Jerry L. Wrisley**, Beaverton; **James H. McGrath, Jr.**; **David T. Engquist**, both of Aloha; **Steve U. Reinhold**, Hillsboro, all of OR (US)

(73) Assignee: **Tektronix, Inc.**, Beaverton, OR (US)

(*) Notice: This patent is subject to a terminal disclaimer.

(**) Term: **14 Years**

(21) Appl. No.: **29/120,011**

(22) Filed: **Mar. 13, 2000**

(51) **LOC (7) Cl. 10-04**

(52) **U.S. Cl. D10/78**

(58) **Field of Search** D10/46, 75, 78, D10/81; D14/100; 73/336.5, 431; 128/630, 745, 746; 324/158; 340/573.1, 573.3, 601, 576, 521; 364/413.02, 413.07-413.09

(56) **References Cited**

U.S. PATENT DOCUMENTS

D. 383,400	*	9/1997	Wada	D10/65
D. 412,156	*	7/1999	Mizusugi et al.	D14/100
5,410,474	*	4/1995	Fox	600/300
6,111,501	*	8/2000	Honeyager et al.	340/521

* cited by examiner

Primary Examiner—Antoine Duval Davis

(74) *Attorney, Agent, or Firm*—William K. Bucher; Francis I. Gray

(57) **CLAIM**

The ornamental design for a modular measurement instrument, as shown and described.

DESCRIPTION

The ornamental design disclosed in this application is for a modular measurement instrument having a display and

processor module with raised bumper guards at the corners, a bi-level rear surface, an array of raised protrusions on the right and left sides of the display screen, an array of ribs formed on the left side of the instrument and extending onto the top and bottom surfaces with the top surface ribs terminating adjacent to the array of raised protrusions, and array of raised protrusions on the rear surface of the instrument adjacent to the ribs and a measurement module positioned on the lower surface of the bi-level rear surface such that the top surface of the measurement module is higher than the upper surface of the bi-level rear surface with the rear surface of the measurement module having an array of raised protrusions adjacent to the right side surface of the modular measurement instrument.

FIG. 1 is a perspective view of a modular measurement instrument;

FIG. 2 is a front elevation view of the modular measurement instrument;

FIG. 3 is a rear elevation view of the modular measurement instrument;

FIG. 4 is a left side elevation view of the modular measurement instrument;

FIG. 5 is a right side elevation view of the modular measurement instrument;

FIG. 6 is a top plan view of the modular measurement instrument; and,

FIG. 7 is a bottom plan view of the modular measurement instrument.

1 Claim, 5 Drawing Sheets

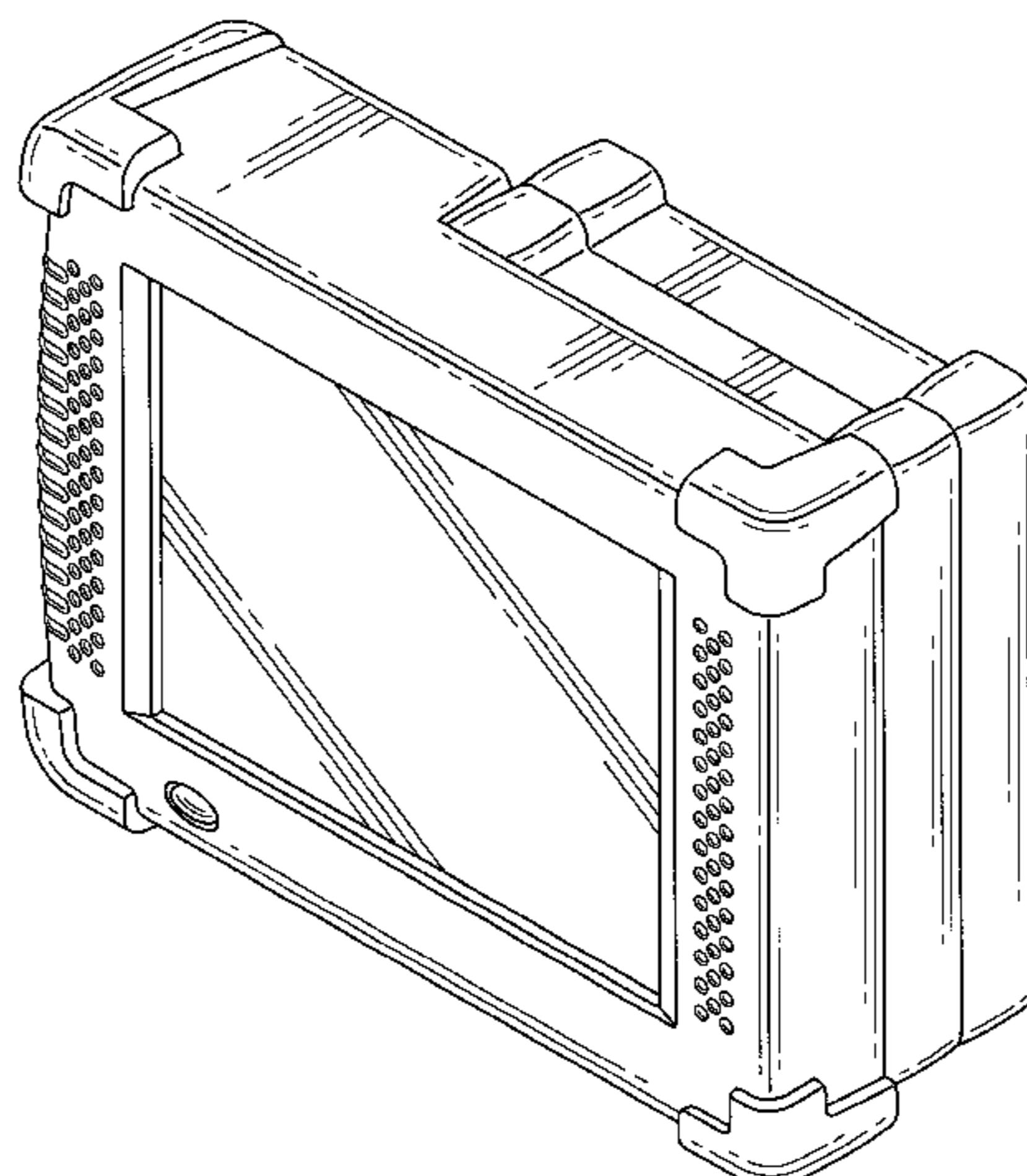

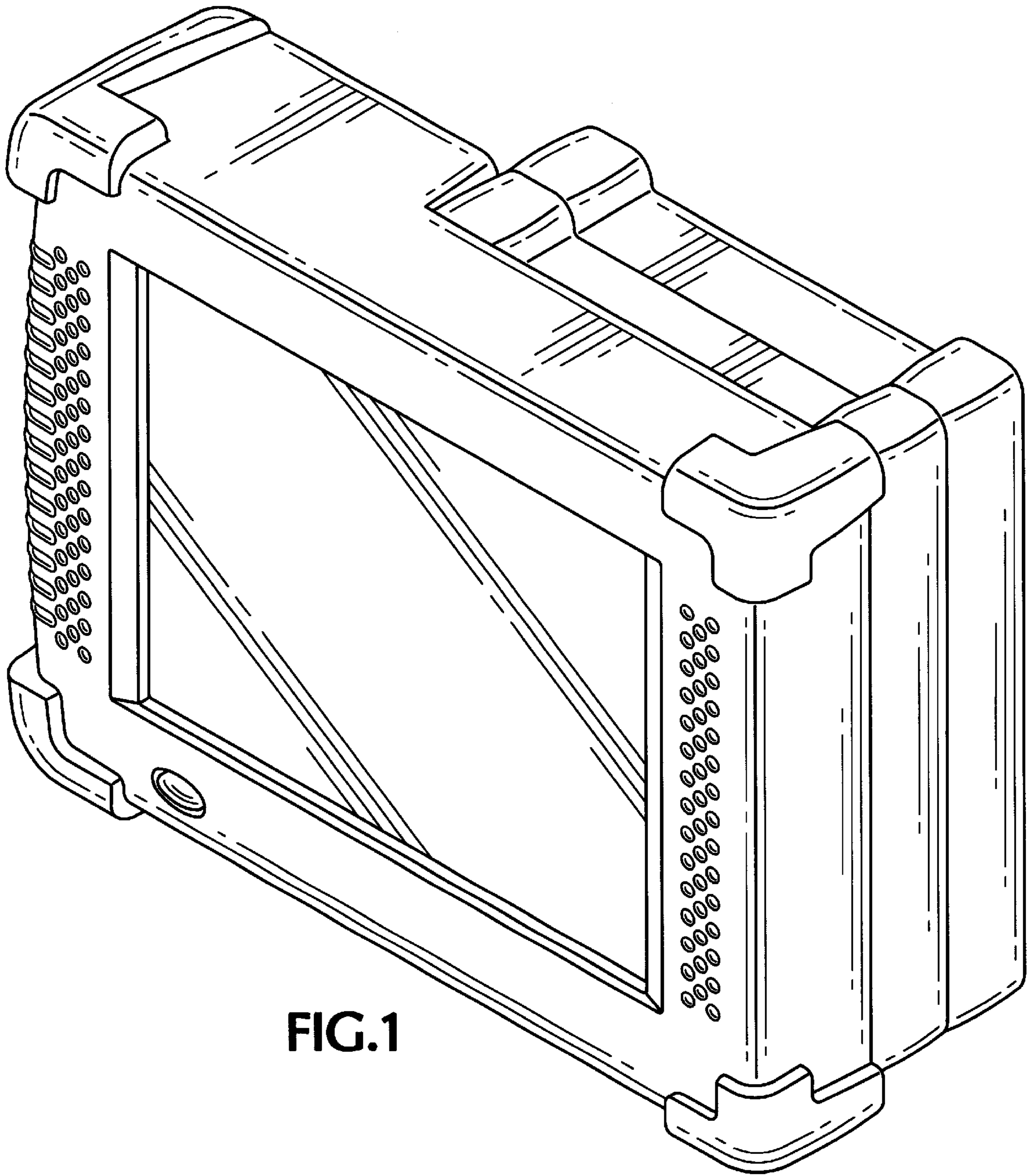

FIG.1

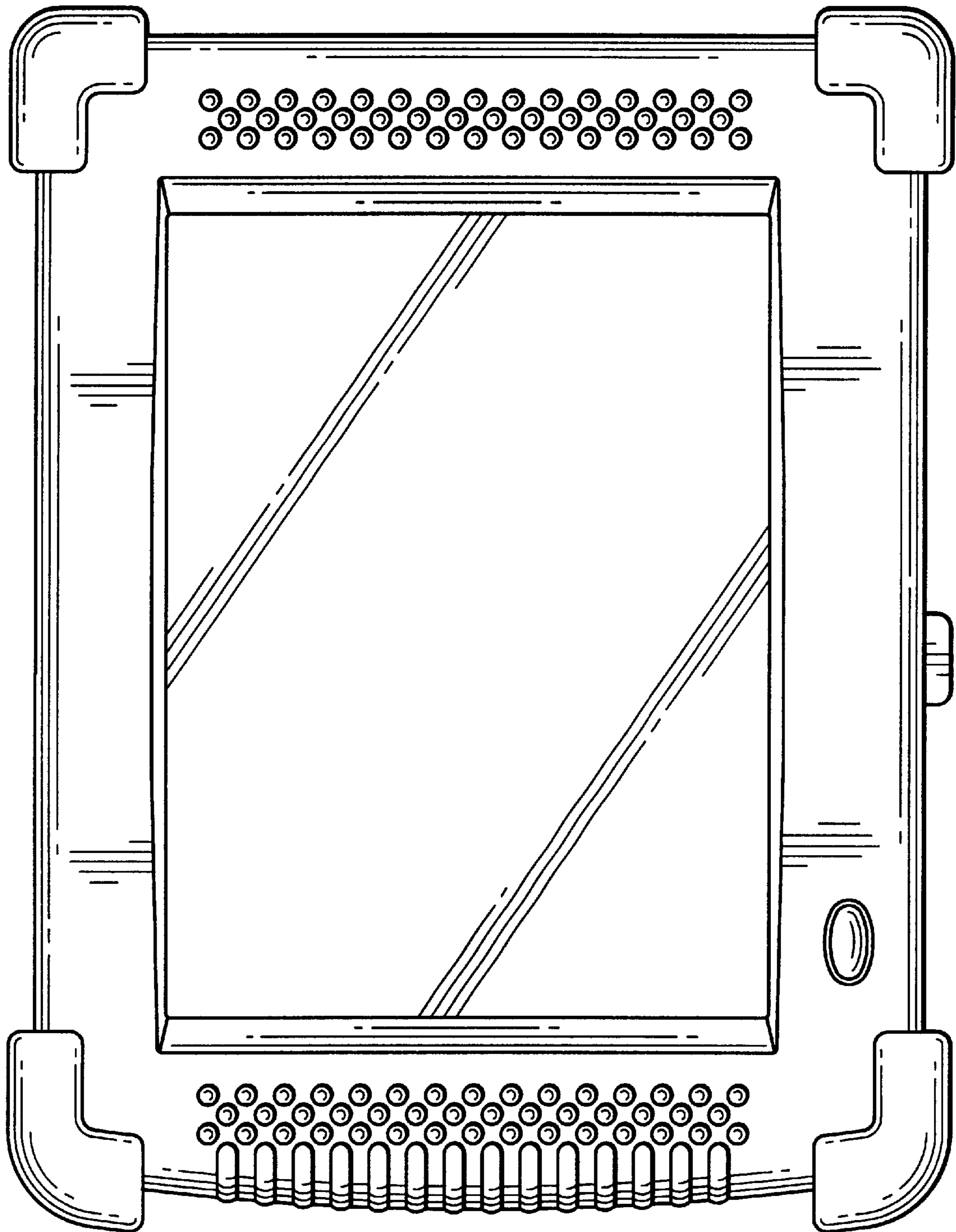

FIG.2

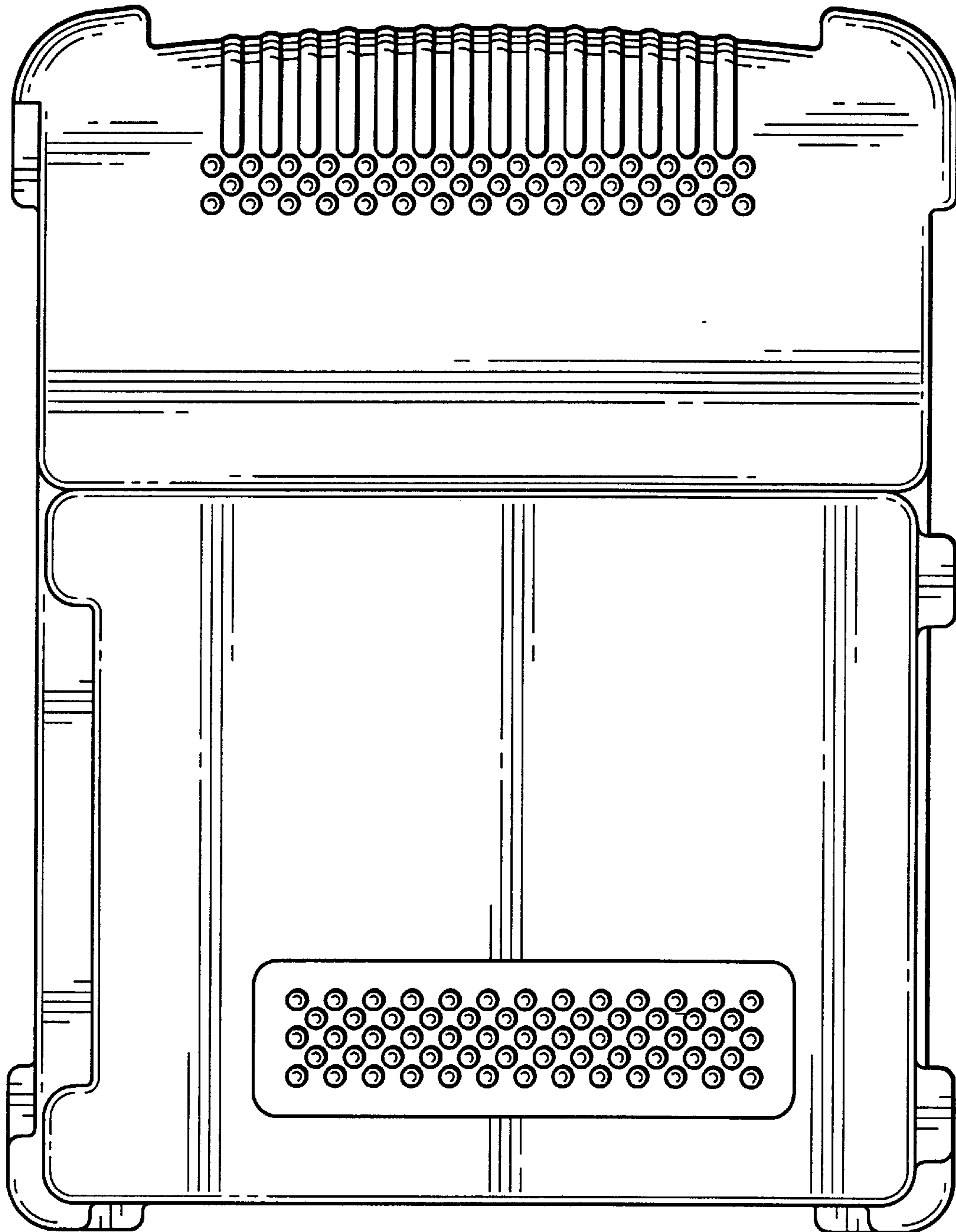

FIG.3

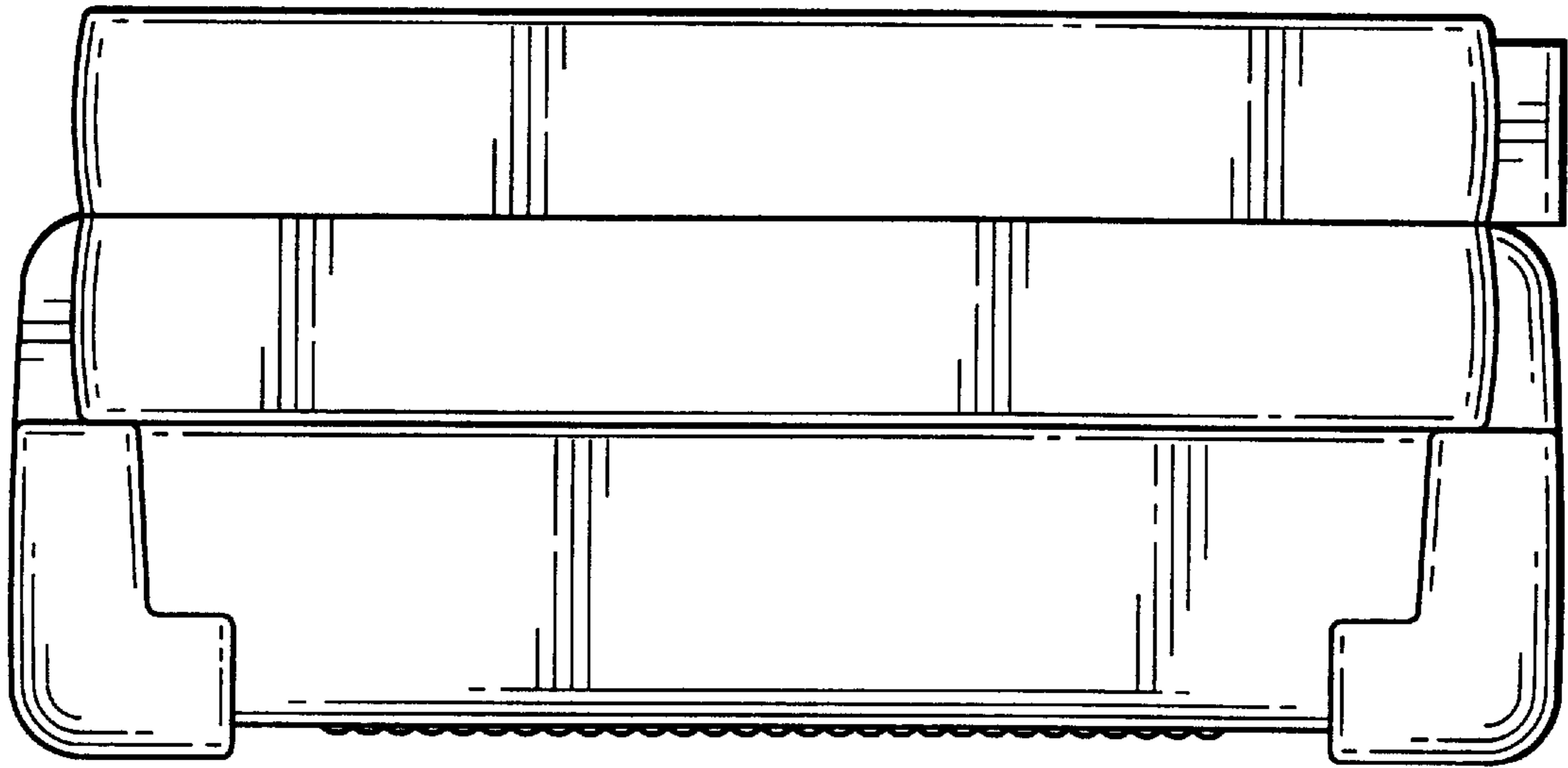

FIG. 5

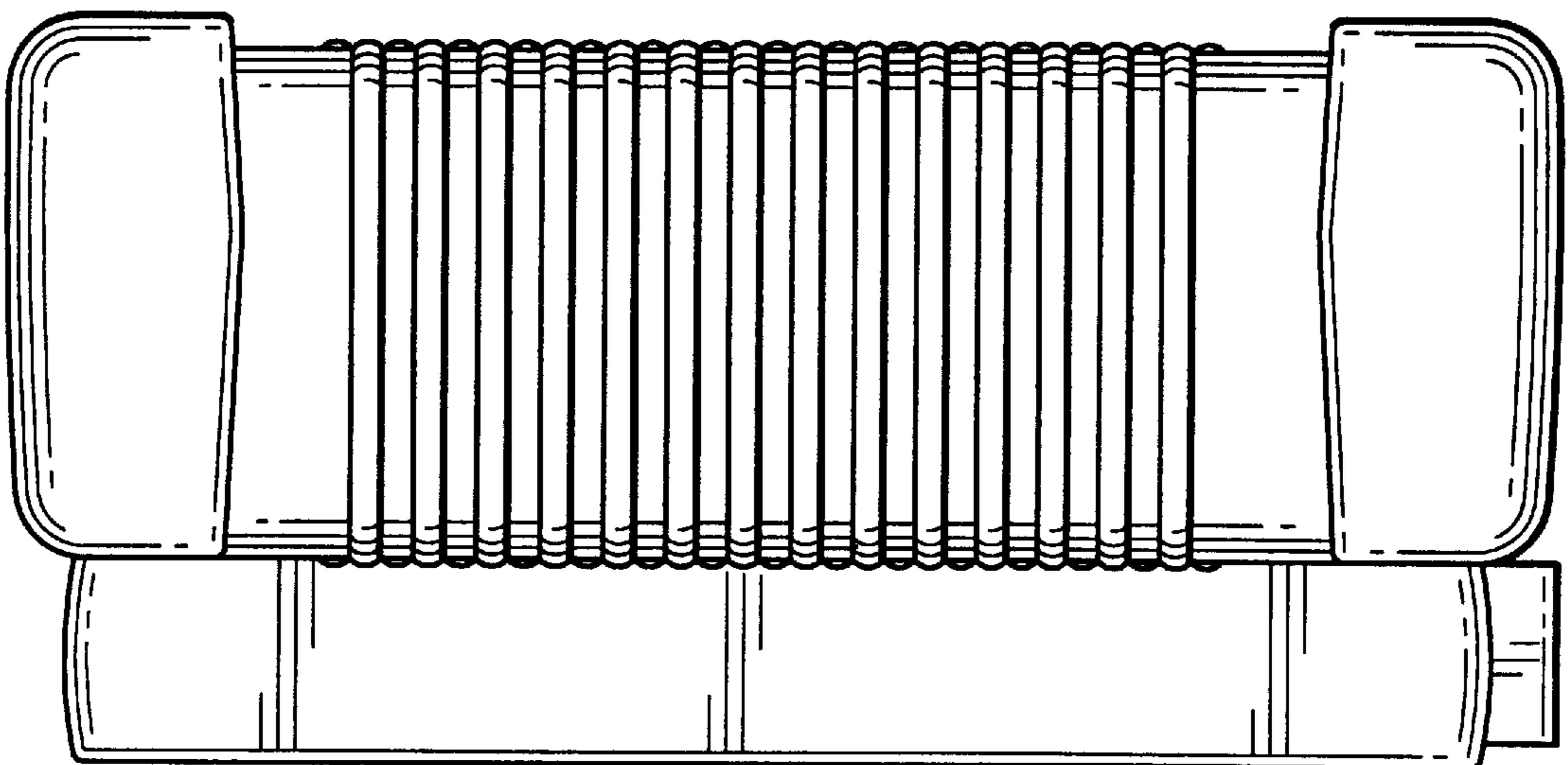

FIG. 4

FIG.6

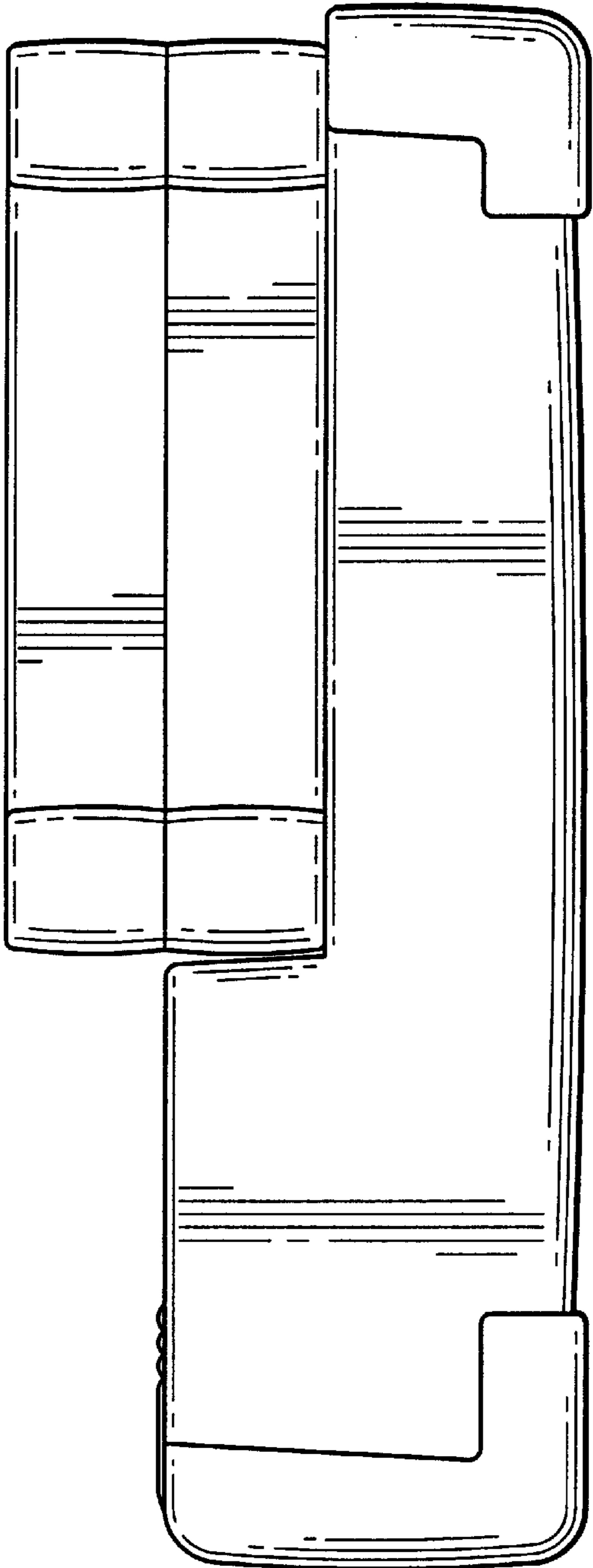

FIG.7

