



US00D444010S

(12) **United States Design Patent**
Ambrosio

(10) **Patent No.:** **US D444,010 S**

(45) **Date of Patent:** **** Jun. 26, 2001**

(54) **INTERCHANGEABLE SEAT BACK
LAMINATE PANEL**

(75) Inventor: **Neil Ambrosio**, Sunrise, FL (US)

(73) Assignee: **Pompeii Furniture Co., Inc.**, Miami,
FL (US)

(**) Term: **14 Years**

(21) Appl. No.: **29/137,217**

(22) Filed: **Feb. 16, 2001**

Related U.S. Application Data

(62) Division of application No. 29/109,472, filed on Aug. 16,
1999.

(51) **LOC (7) Cl.** **06-06**

(52) **U.S. Cl.** **D6/502**

(58) **Field of Search** D6/334, 339, 348,
D6/360, 374, 379, 380, 500-502; 297/452.38

(56) **References Cited**

U.S. PATENT DOCUMENTS

- D. 289,469 * 4/1987 Tonon D6/379
- D. 331,157 * 11/1992 Bennett D6/379
- D. 332,531 * 1/1993 Guion D6/379
- D. 350,443 * 9/1994 Lowsky D6/379

OTHER PUBLICATIONS

Four chairs at bottom of p. 92, *Schoner Wohen* magazine,
Sep. 1988.*

Chair with round backrest on top, p. 152, *Schoner Wohen*
magazine, Jun. 1987.*

1033 Cushion Back Barstool Swivel, 1061 Counter Seat
Cushion Back p. 5, US Seating Product brochure, Mar.
1989.*

* cited by examiner

Primary Examiner—Doris V. Coles

Assistant Examiner—Mimosa De

(74) *Attorney, Agent, or Firm*—Richard S. Ross, Esq.

(57) **CLAIM**

The ornamental design for an interchangeable seat back
laminate panel, as shown and described.

DESCRIPTION

FIG. 1 is a rear perspective view of a first embodiment of an
interchangeable seat back laminate panel showing my new
design;

FIG. 2 is a greatly enlarged cross sectional view thereof
taken along line 2—2 in FIG. 1, it being understood that the
panel has been broken away in the middle for convenience
of illustration;

FIG. 3 is an enlarged rear elevational view thereof;

FIG. 4 is a rear perspective view of a second embodiment of
an interchangeable seat back laminate panel showing my
new design;

FIG. 5 is a greatly enlarged cross sectional view thereof
taken along line 5—5 in FIG. 4, it being understood that the
panel has been broken away in the middle for convenience
of illustration; and,

FIG. 6 is an enlarged rear elevational view thereof.

The broken line showing of the environmental structure in
FIGS. 1, 2, 4, and 5 of the drawing is for illustrative purposes
only and forms no part of the claimed design.

1 Claim, 2 Drawing Sheets

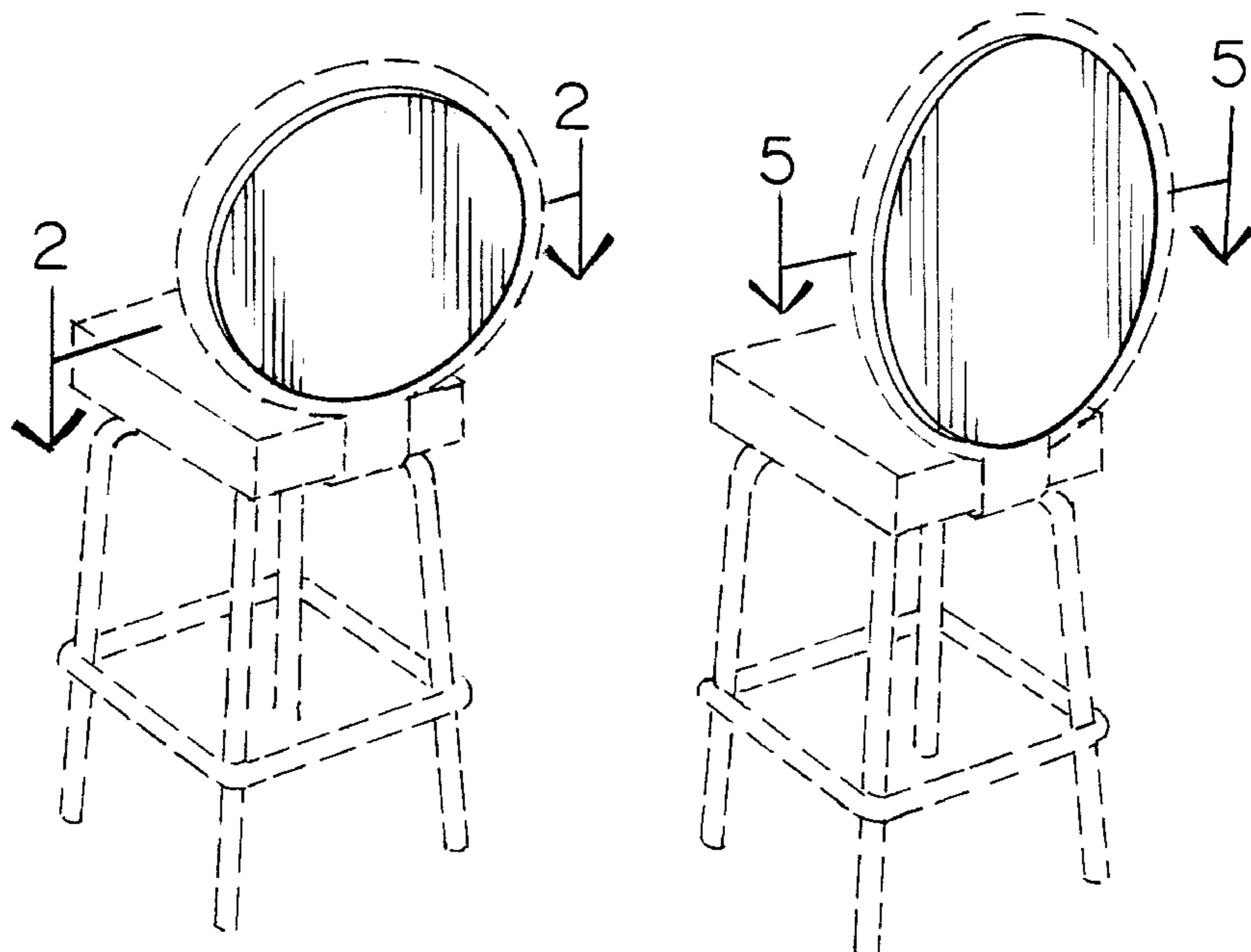

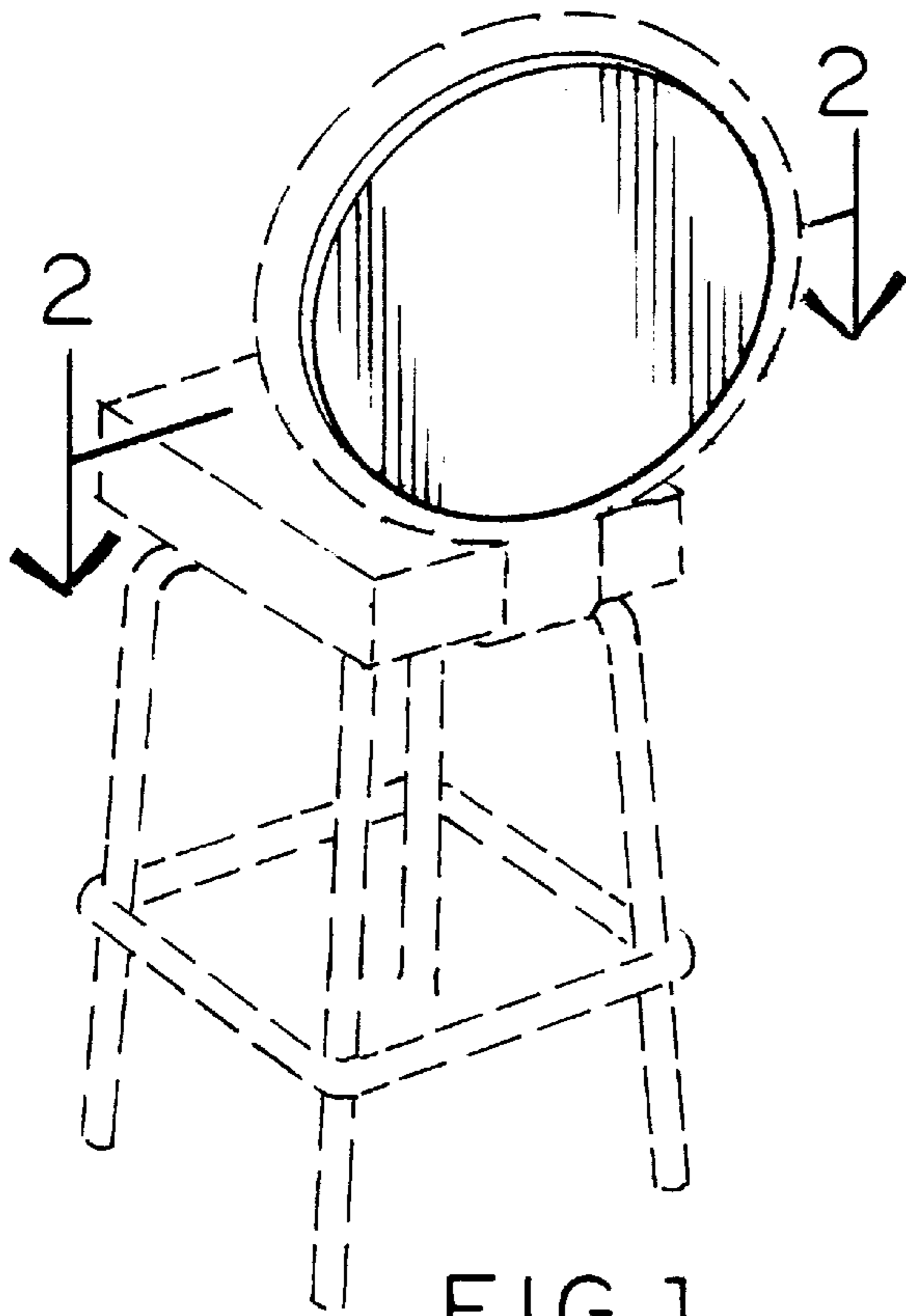

FIG. 1

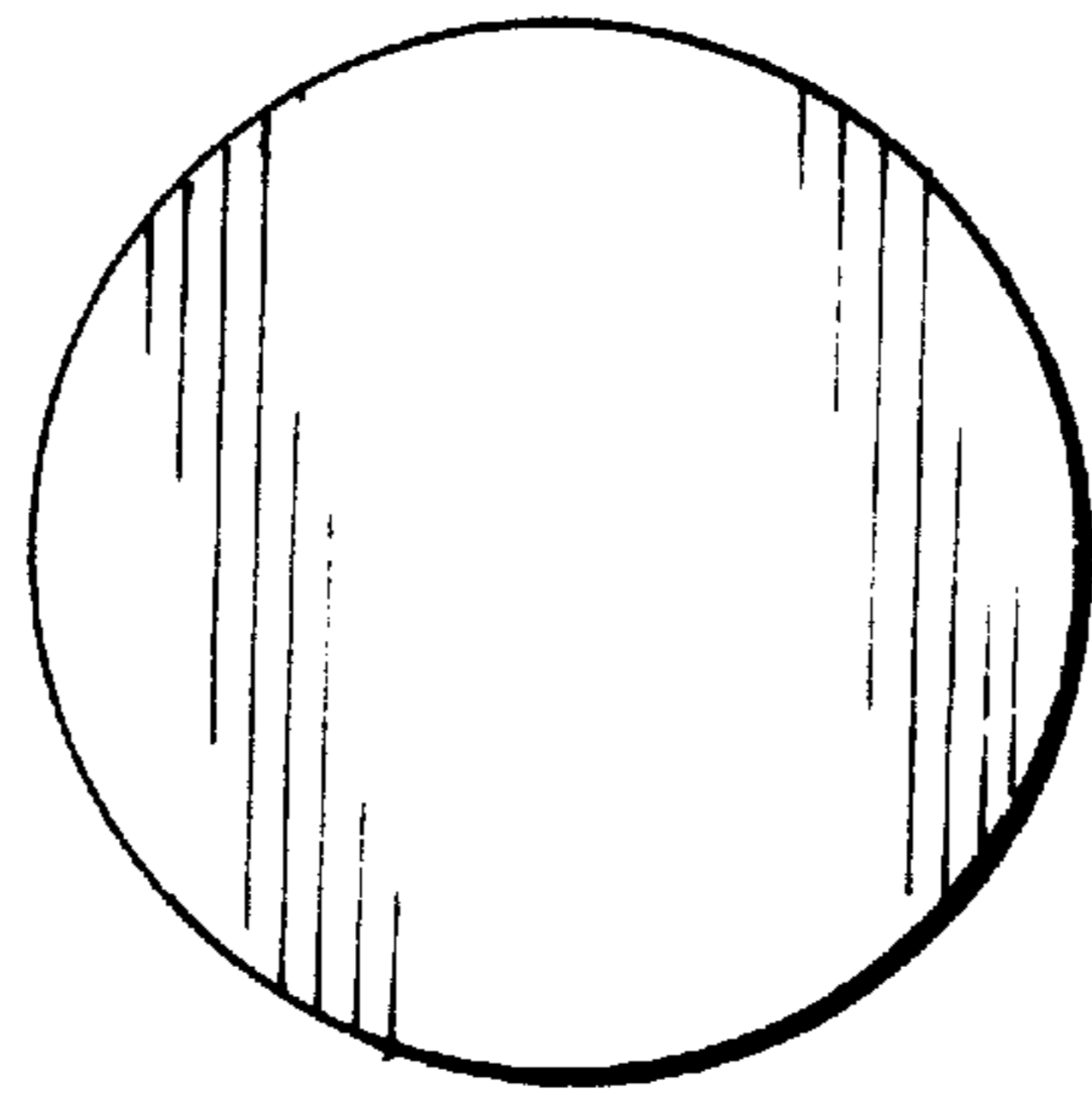

FIG. 3

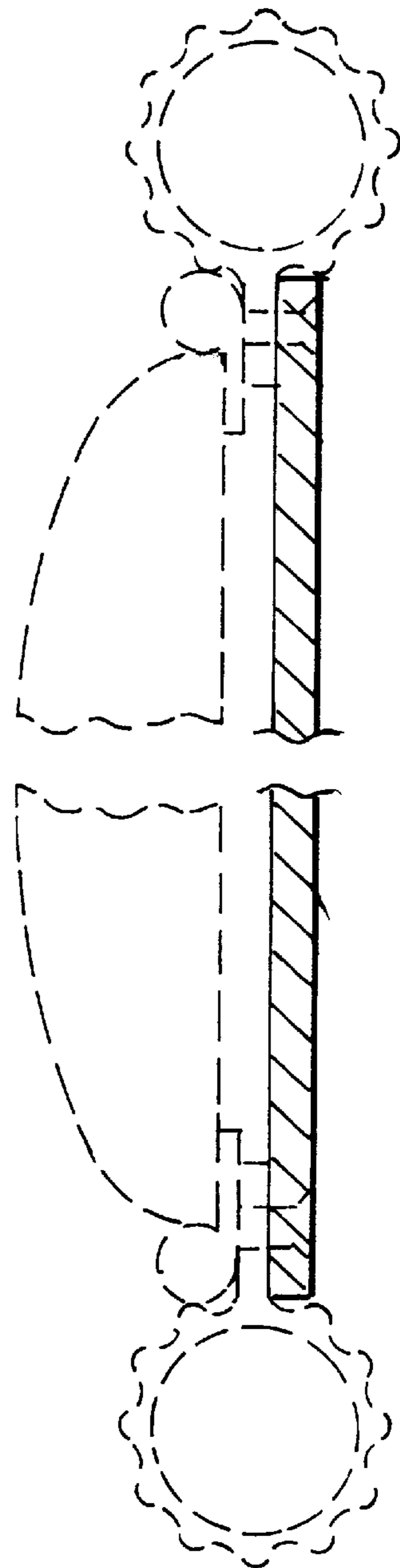

FIG. 2

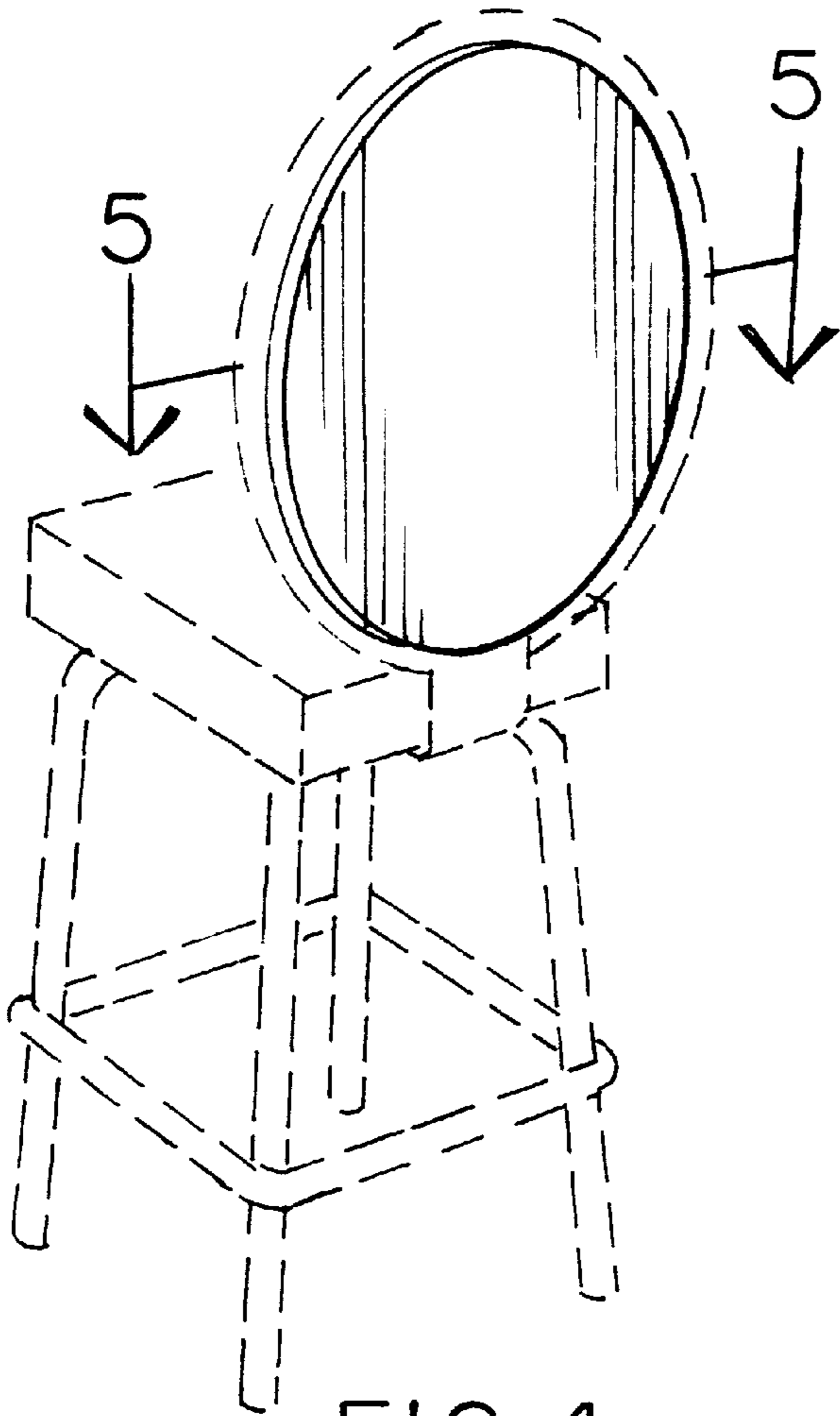

FIG. 4

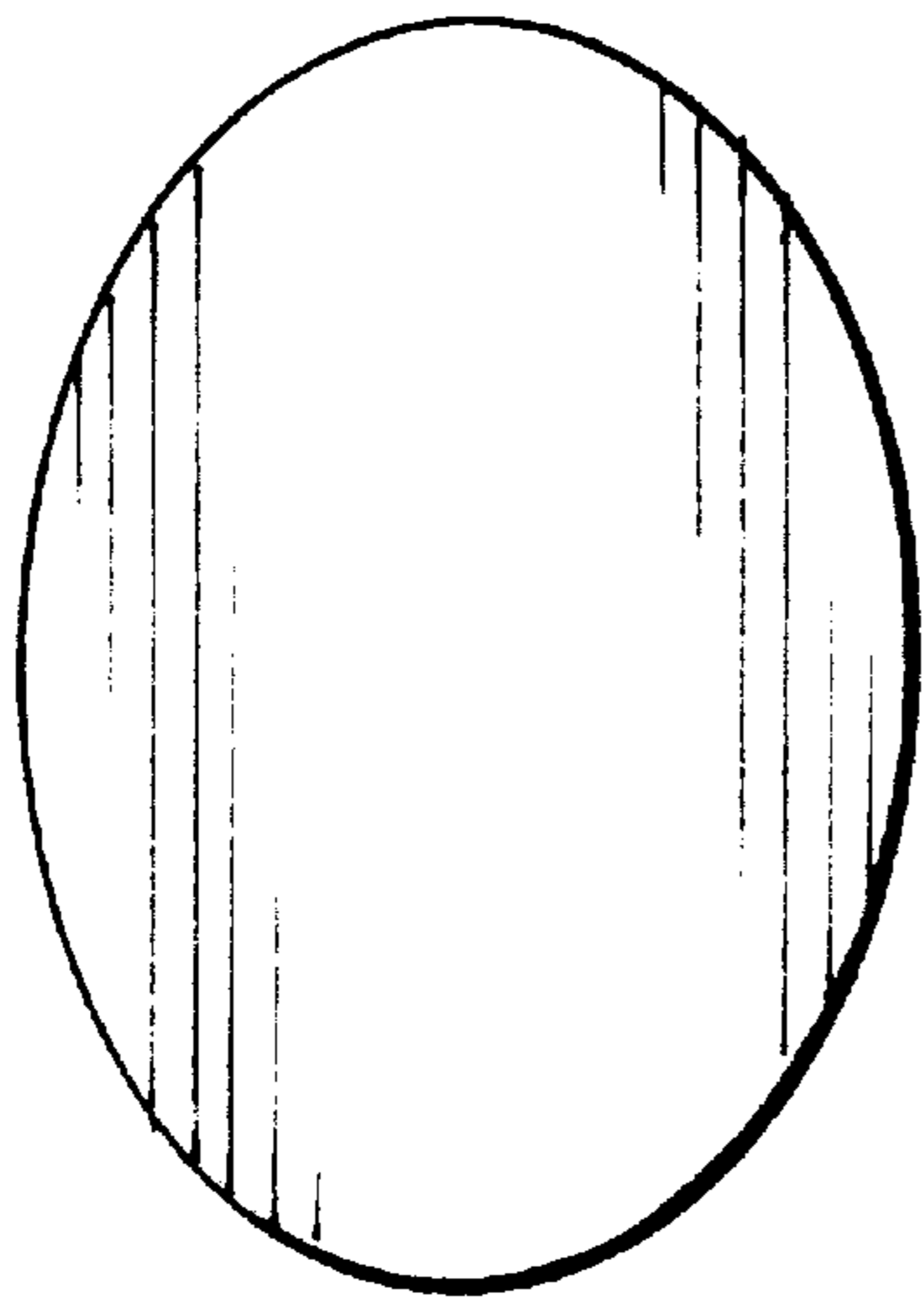

FIG. 6

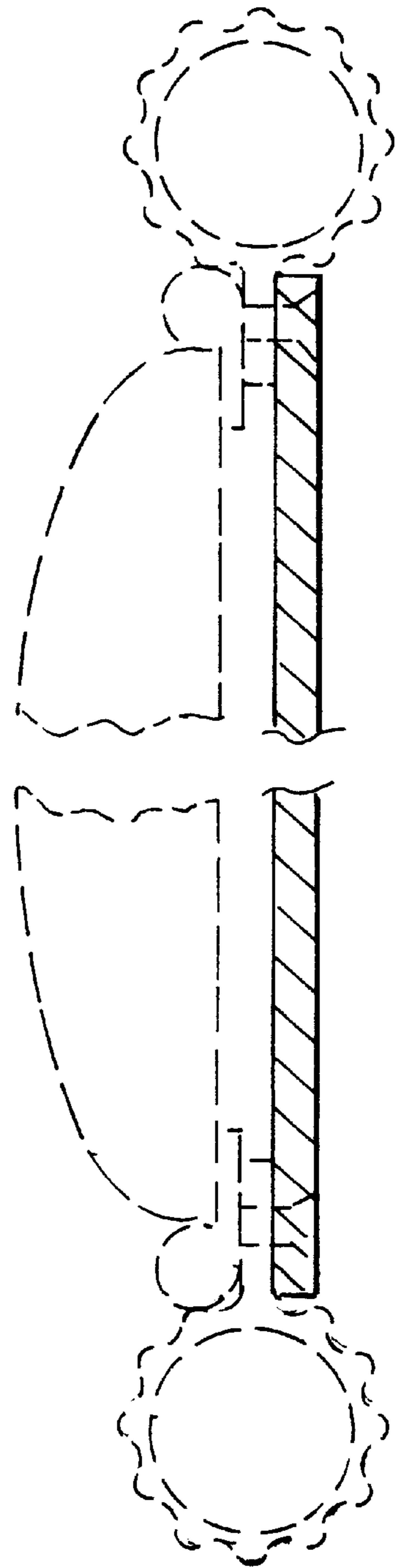

FIG. 5