



US00D443936S

(12) **United States Design Patent**
Biro

(10) **Patent No.:** **US D443,936 S**

(45) **Date of Patent:** **** Jun. 19, 2001**

(54) **ELONGATED FLOORING MEMBER
HAVING A NON-SLIP TREAD AND
COVERED ATTACHMENT CHANNELS**

(76) **Inventor:** **Michael Julius Biro**, 4014 NW. 24th
Ter., Boca Raton, FL (US) 33431

(**) **Term:** **14 Years**

(21) **Appl. No.:** **29/123,271**

(22) **Filed:** **May 15, 2000**

Related U.S. Application Data

(60) Continuation of application No. 09/228,734, filed on Jan. 12, 1999, now Pat. No. 6,062,844, which is a division of application No. 09/079,665, filed on May 14, 1998, now Pat. No. 5,904,011.

(51) **LOC (7) Cl.** **25-01**

(52) **U.S. Cl.** **D25/122**

(58) **Field of Search** D25/122, 138,
D25/124; 405/196, 201, 218; 14/73, 119,
164, 6, 123; 52/177, 179

(56) **References Cited**

U.S. PATENT DOCUMENTS

D. 422,718 * 4/2000 Chaney et al. D25/122

D. 429,347 * 8/2000 Doyle et al. D25/124

* cited by examiner

Primary Examiner—Doris Clark

(74) *Attorney, Agent, or Firm*—Ronald V. Davidge

(57) **CLAIM**

The ornamental design for an elongated flooring member having a non-slip tread and covered attachment channels, as shown and described.

DESCRIPTION

FIG. 1 is a left end elevation of the elongated flooring member having a non-slip tread and covered attachment channels, showing my new design, the right end elevation being identical;

FIG. 2 is a top plan view thereof;

FIG. 3 is a front elevation thereof, the rear elevation being identical;

FIG. 4 is a bottom plan view thereof;

FIG. 5 is an enlarged fragmentary plan view of a tread pattern on an upper surface thereof;

FIG. 6 is an enlarged fragmentary transverse cross-sectional view of the tread pattern of FIG. 5;

FIG. 7 is an enlarged fragmentary longitudinal cross-sectional view of the tread pattern of FIG. 5; and,

FIG. 8 is a perspective view of the elongated flooring member having a non-slip tread and covered attachment channels of FIG. 1.

FIGS. 2–4 and 8 are shown broken away to indicate indeterminate length.

1 Claim, 3 Drawing Sheets

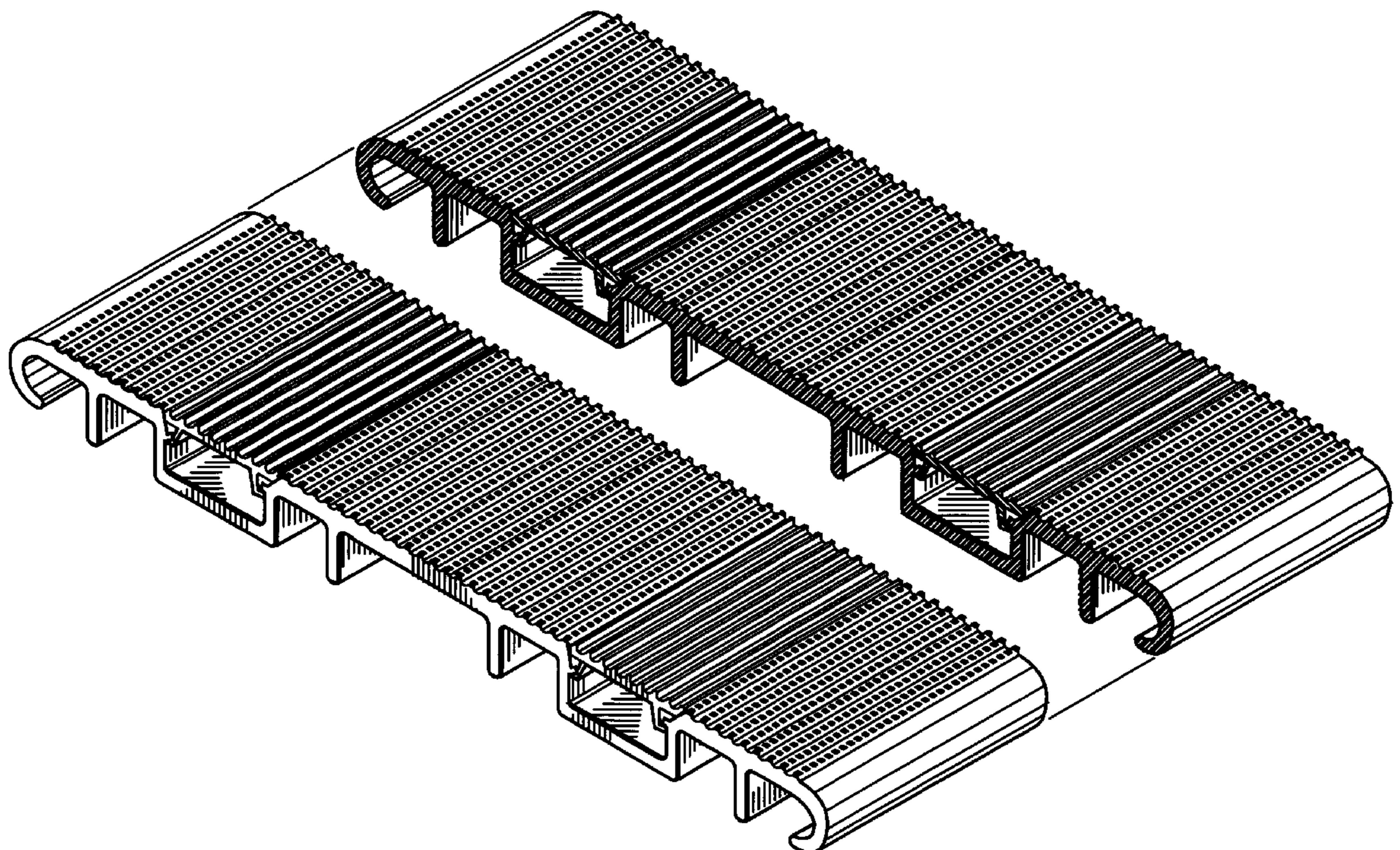



FIG. 1

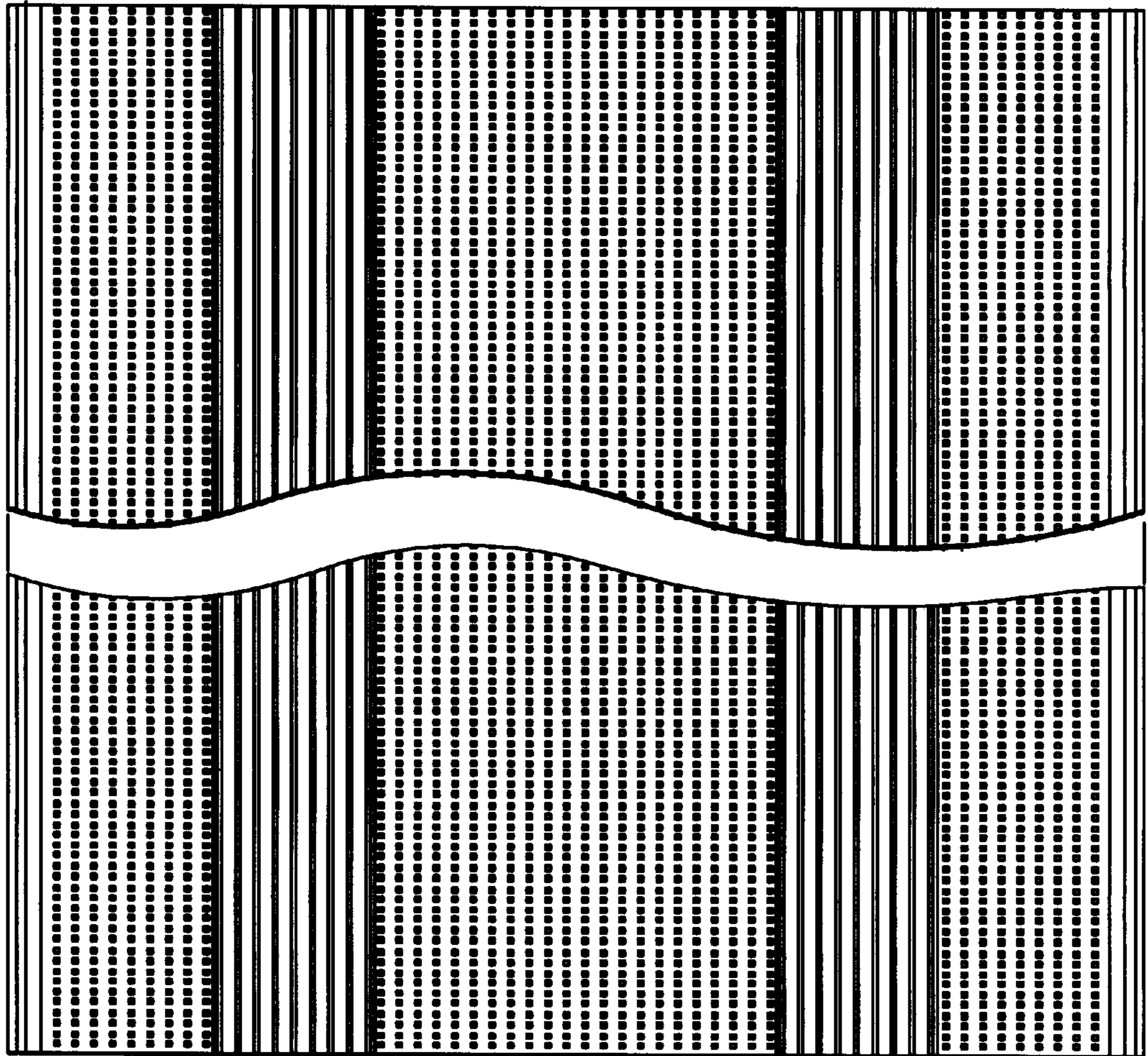

FIG. 2



FIG. 3

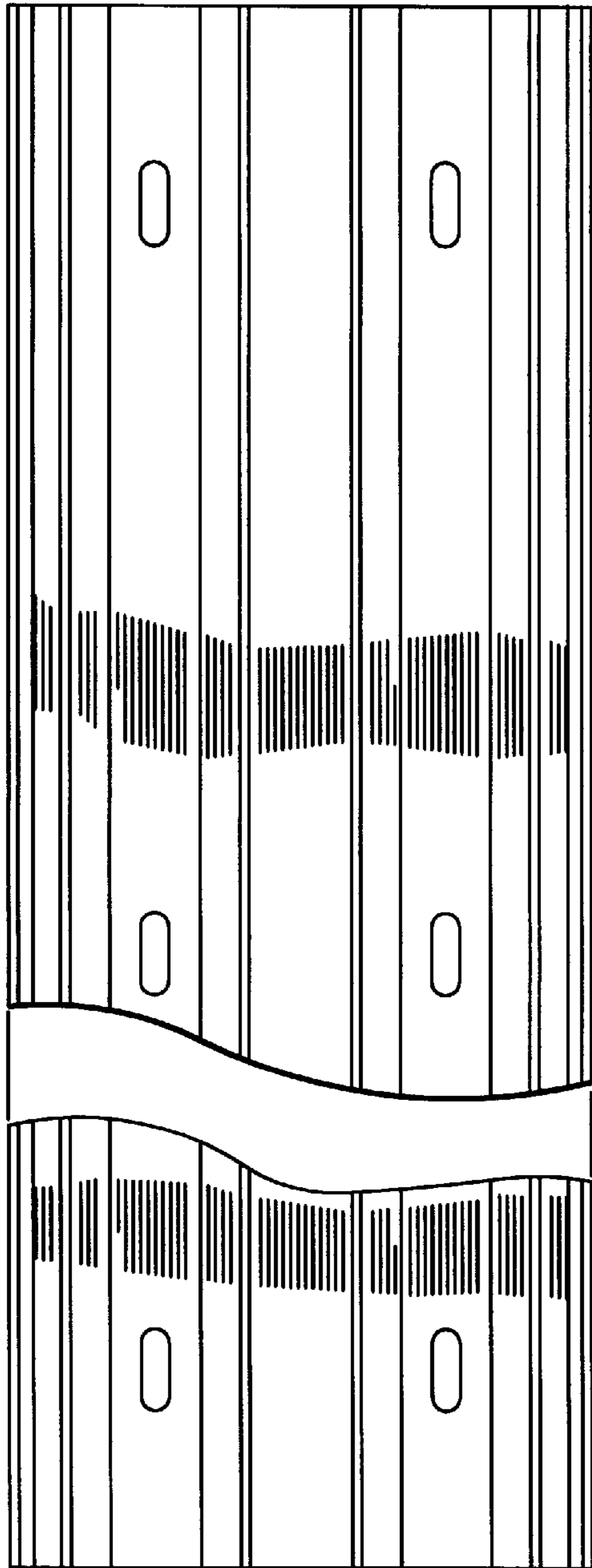

FIG. 4

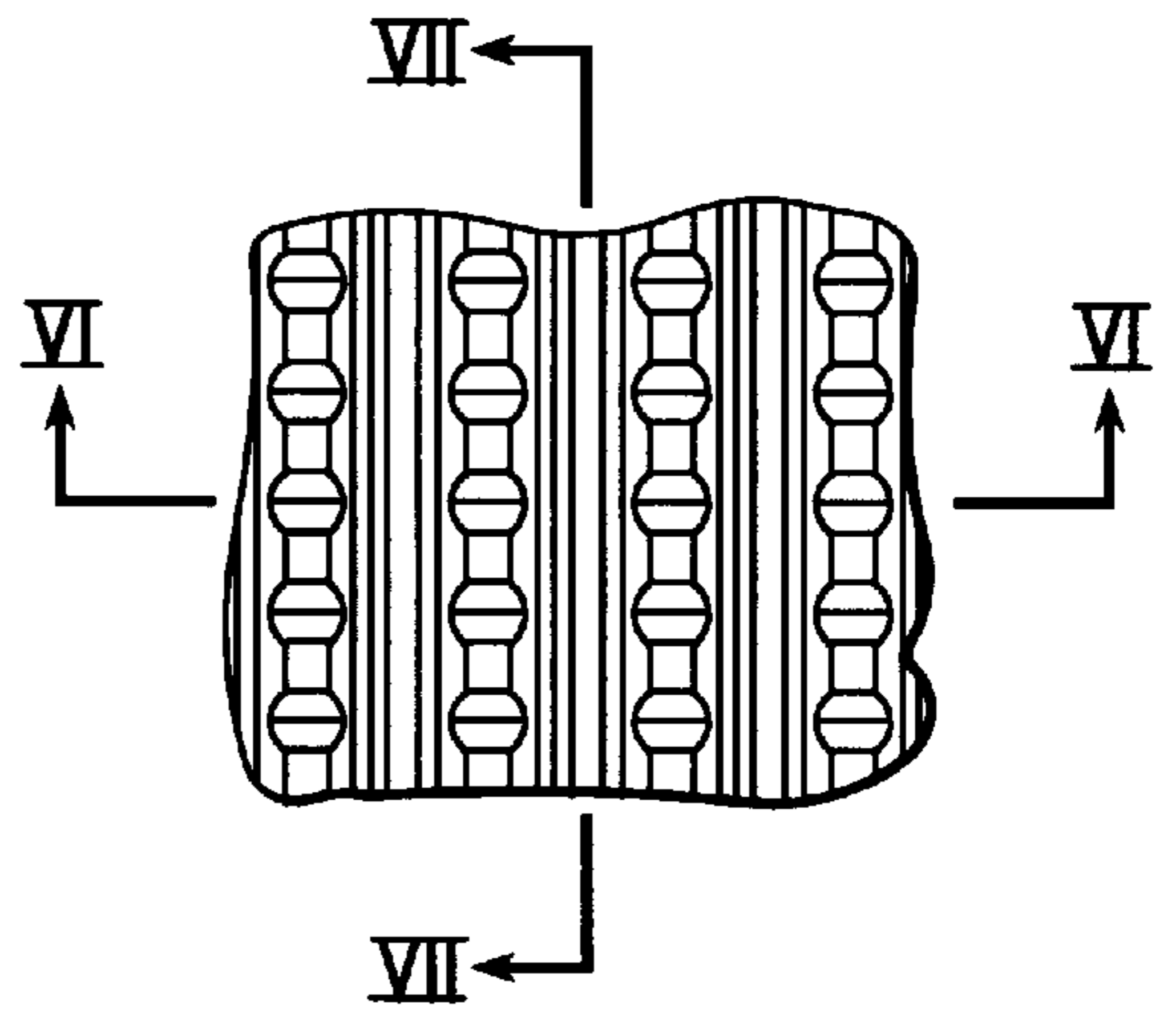

FIG. 5

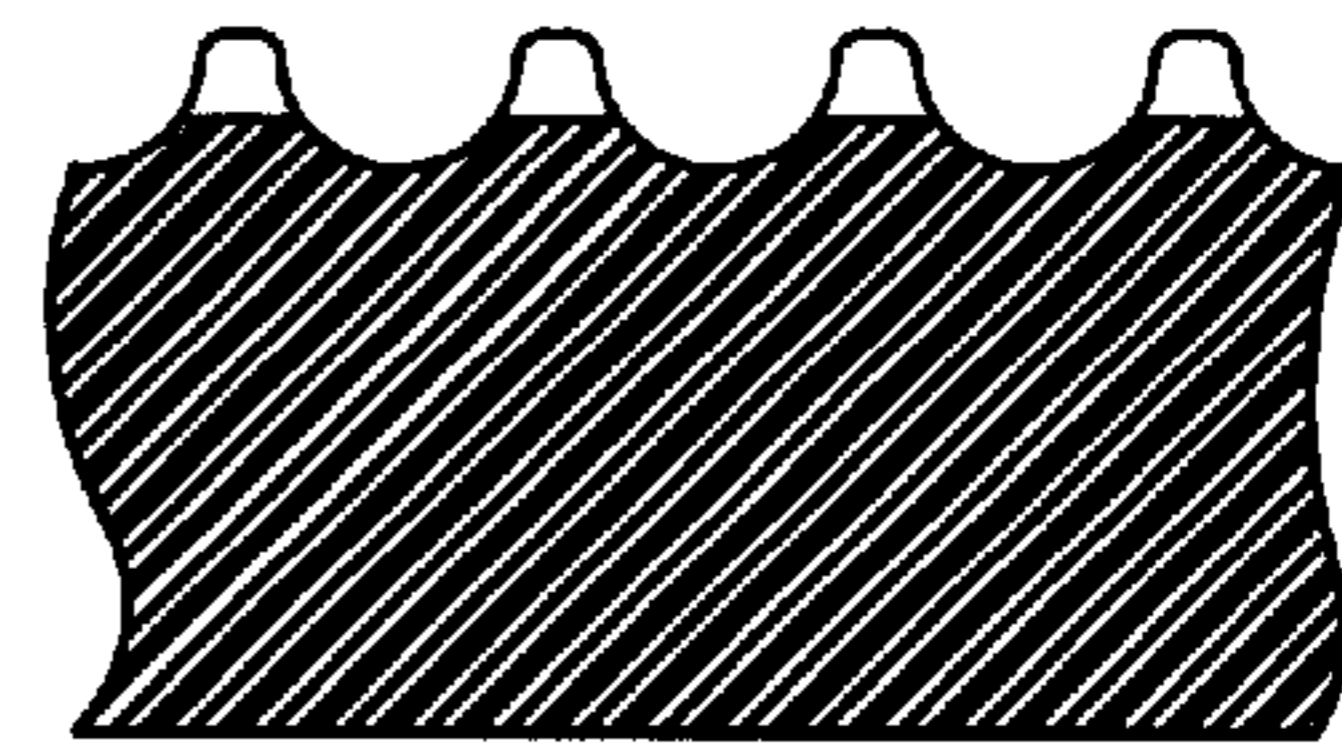

FIG. 6

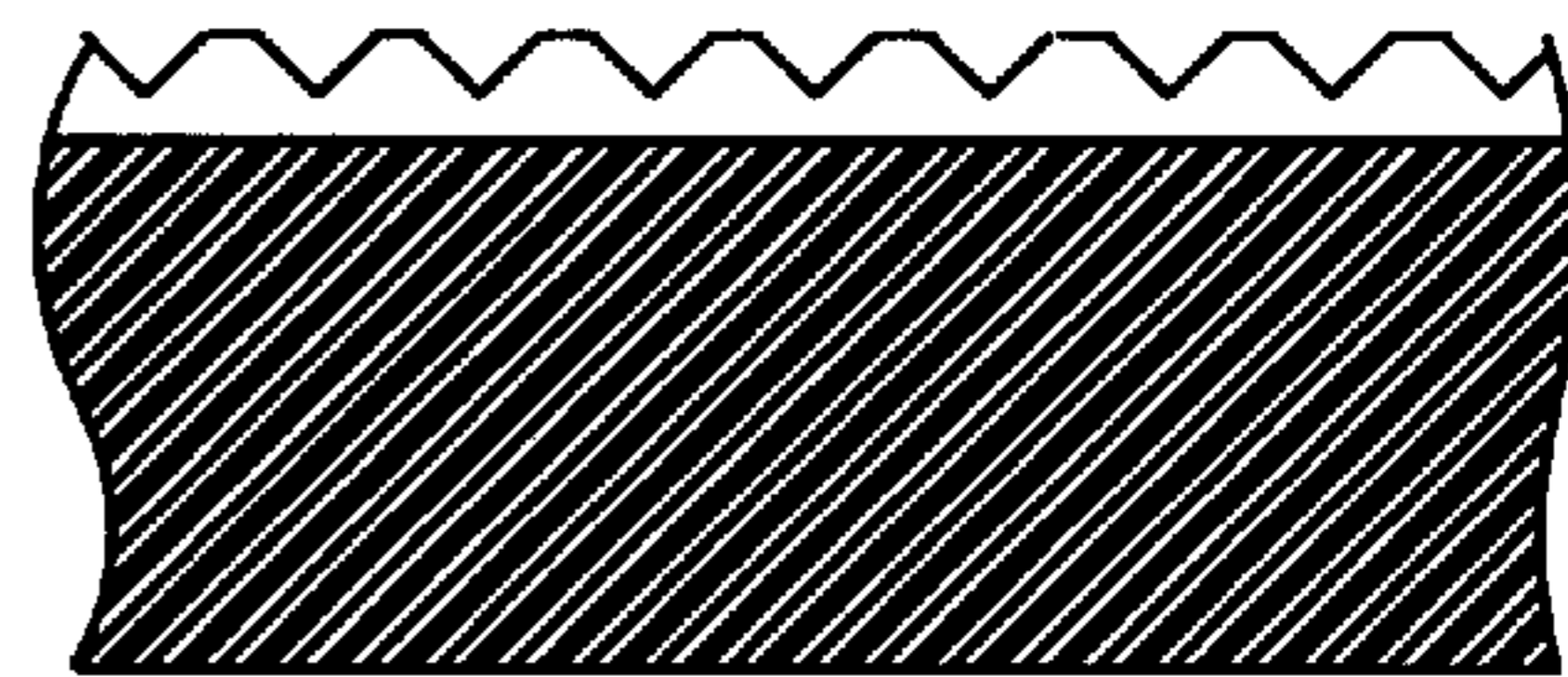

FIG. 7

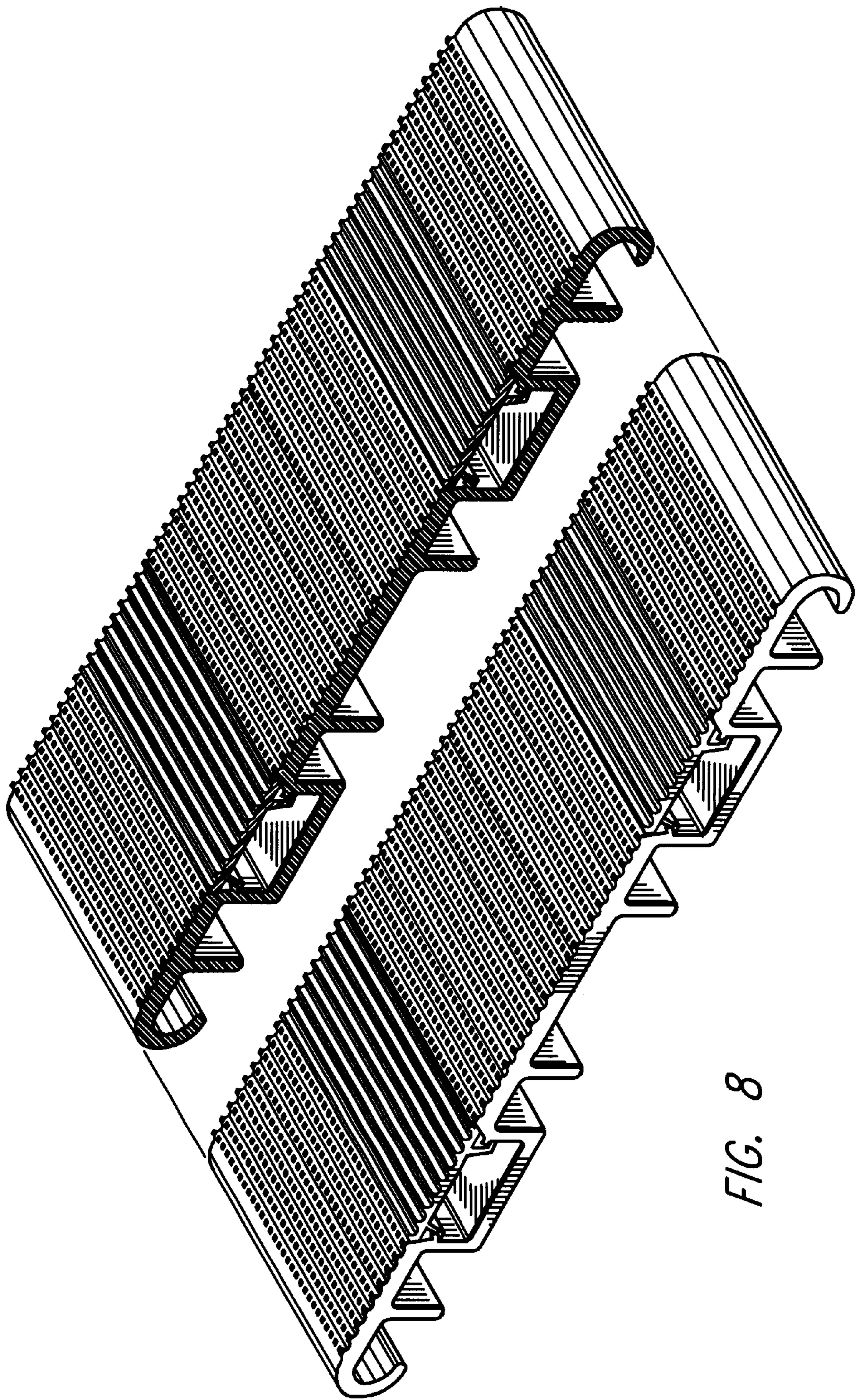

FIG. 8