



US00D443744S

(12) **United States Design Patent**
Intravatola

(10) **Patent No.:** **US D443,744 S**

(45) **Date of Patent:** **** Jun. 12, 2001**

(54) **CART FRAME**

(75) **Inventor:** **Lawrence Shane Intravatola**, Virginia Beach, VA (US)

(73) **Assignee:** **Air Systems, Inc.**, Chesapeake, VA (US)

(**) **Term:** **14 Years**

(21) **Appl. No.:** **29/123,979**

(22) **Filed:** **May 30, 2000**

(51) **LOC (7) Cl.** **12-02**

(52) **U.S. Cl.** **D34/12; D34/25**

(58) **Field of Search** D34/12-27; 280/47.24, 280/47.26, 47.27, 47.28, 47.19, 47.35, 79.11, 79.2, 79.3

(56) **References Cited**

U.S. PATENT DOCUMENTS

D. 311,083	*	10/1990	Dutro	D34/26
D. 330,103	*	10/1992	Andrews, Jr. et al.	D34/20
D. 340,565	*	10/1993	Klopfenstein	D34/25
4,098,416		7/1978	Fawley	.	
4,205,937		6/1980	Fawley	.	
4,253,716		3/1981	Turner, Jr.	.	
4,625,949		12/1986	Walker	.	
4,753,445		6/1988	Ferrare	.	
5,071,148		12/1991	Salvucci, Sr.	.	
5,340,136		8/1994	MacNeil et al.	.	
5,393,080		2/1995	Ross	.	
5,431,422		7/1995	Gamache	.	
5,570,895		11/1996	McCue et al.	.	

OTHER PUBLICATIONS

Air Systems International catalog, "Breathing Air Applications," pp. 1-47, (1999).

Scott brochure, "Scott Mobile Air Cart," (1999).

Catalog page, "High Pressure Air Sources: Air-Cart," (1999).

Catalog page, "SAR Systems," (1999).

SCI Catalog, "Air Source C.A.R.T.," pp. 14A-14B, (1999).
Catalog page, "Spirocart Modular Breathing Air System," (1999).

* cited by examiner

Primary Examiner—Kay H. Chin

(74) *Attorney, Agent, or Firm*—Brinks Hofer Gilson & Lione

(57) **CLAIM**

The ornamental design for a cart frame, as shown and described.

DESCRIPTION

FIG. 1 is a rear perspective view of a preferred embodiment of a cart frame with hanger brackets and a portion of a handle shown in broken lines;

FIG. 2 a front perspective view of the cart frame with hanger brackets and a portion of a handle shown in broken lines;

FIG. 3 is a top view of the cart frame with hanger brackets and a portion of a handle shown in broken lines;

FIG. 4 is a bottom view of the cart frame with hanger bracket shown in broken lines;

FIG. 5 is a rear view of the cart frame with hanger brackets and a portion of a handle shown in broken lines;

FIG. 6 is a right side view of the cart frame with hanger brackets and a portion of a handle shown in broken lines, with the left side view being a mirror image thereof;

FIG. 7 is a front view of the cart frame with hanger bracket and a portion of a handle shown in broken lines;

FIG. 8 is a front view of the cart frame with a handle, hanger bracket, wheels and tanks shown in broken lines; and,

FIG. 9 is a rear perspective view of the cart frame with a handle, wheels, straps and hanger brackets shown in broken lines.

The broken lines showing the wheels, tanks, straps, hanger brackets and handle, or portion thereof, in FIGS. 1-9 are for illustrative or environmental purposes only and do not form any part of the claimed design.

1 Claim, 3 Drawing Sheets

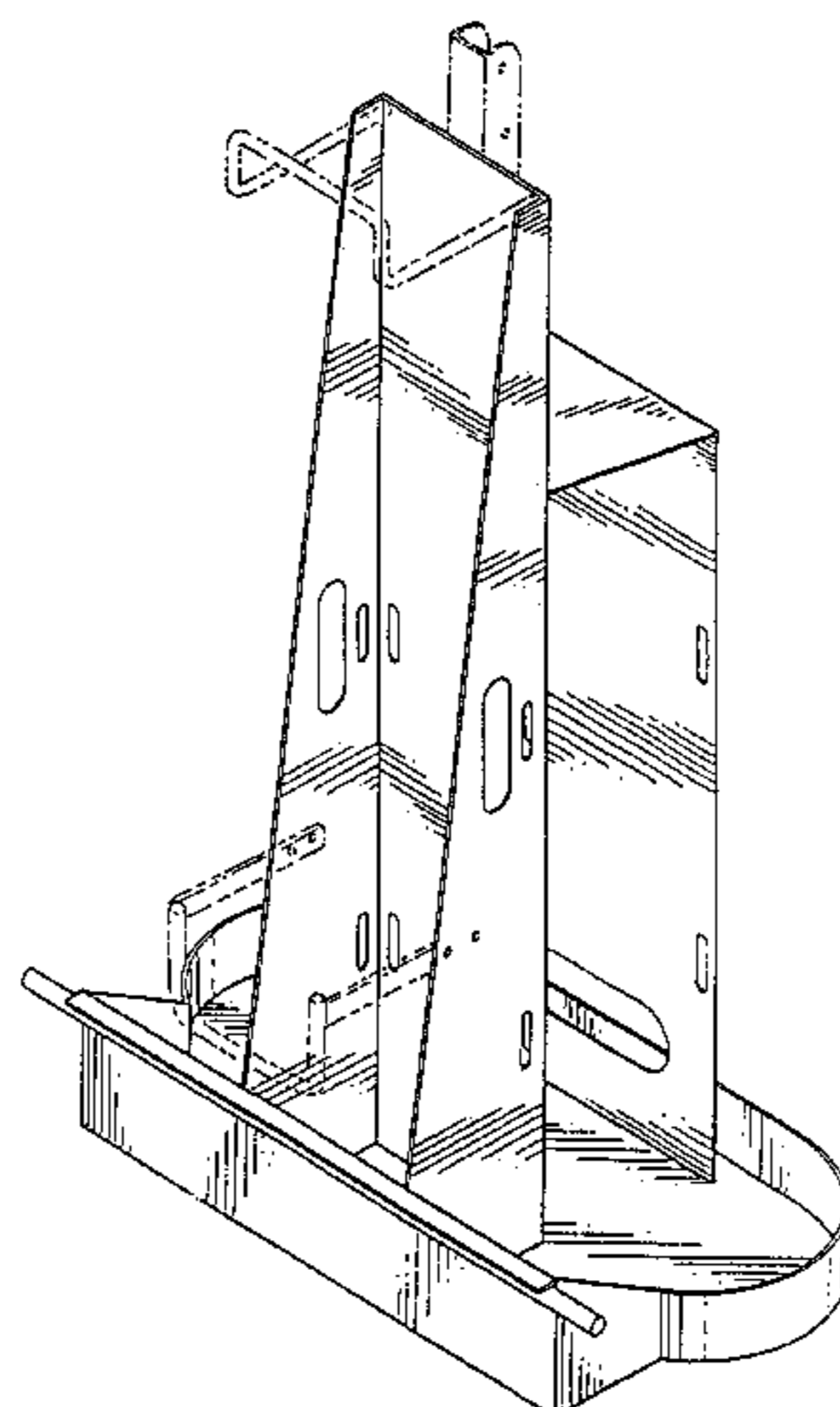

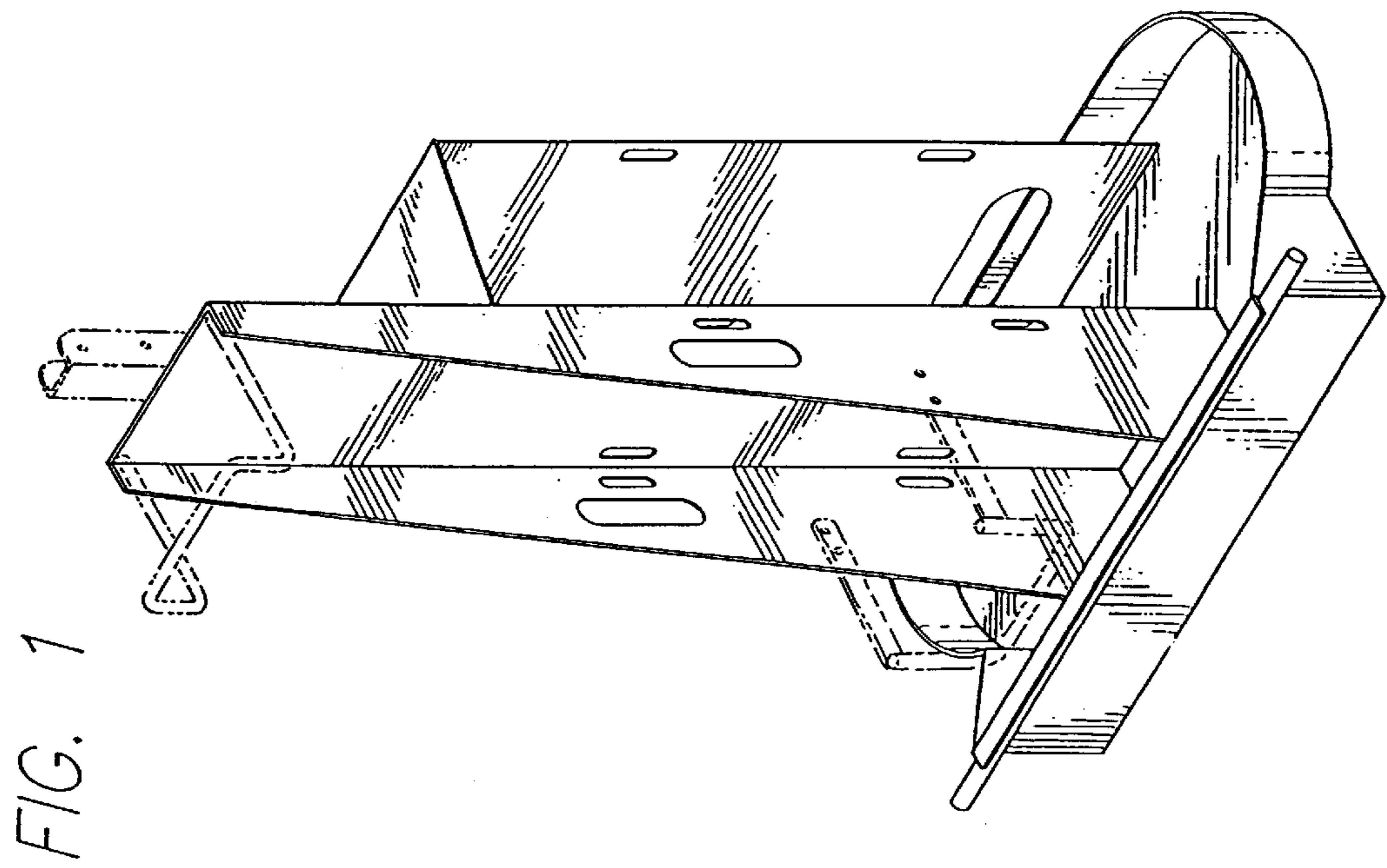
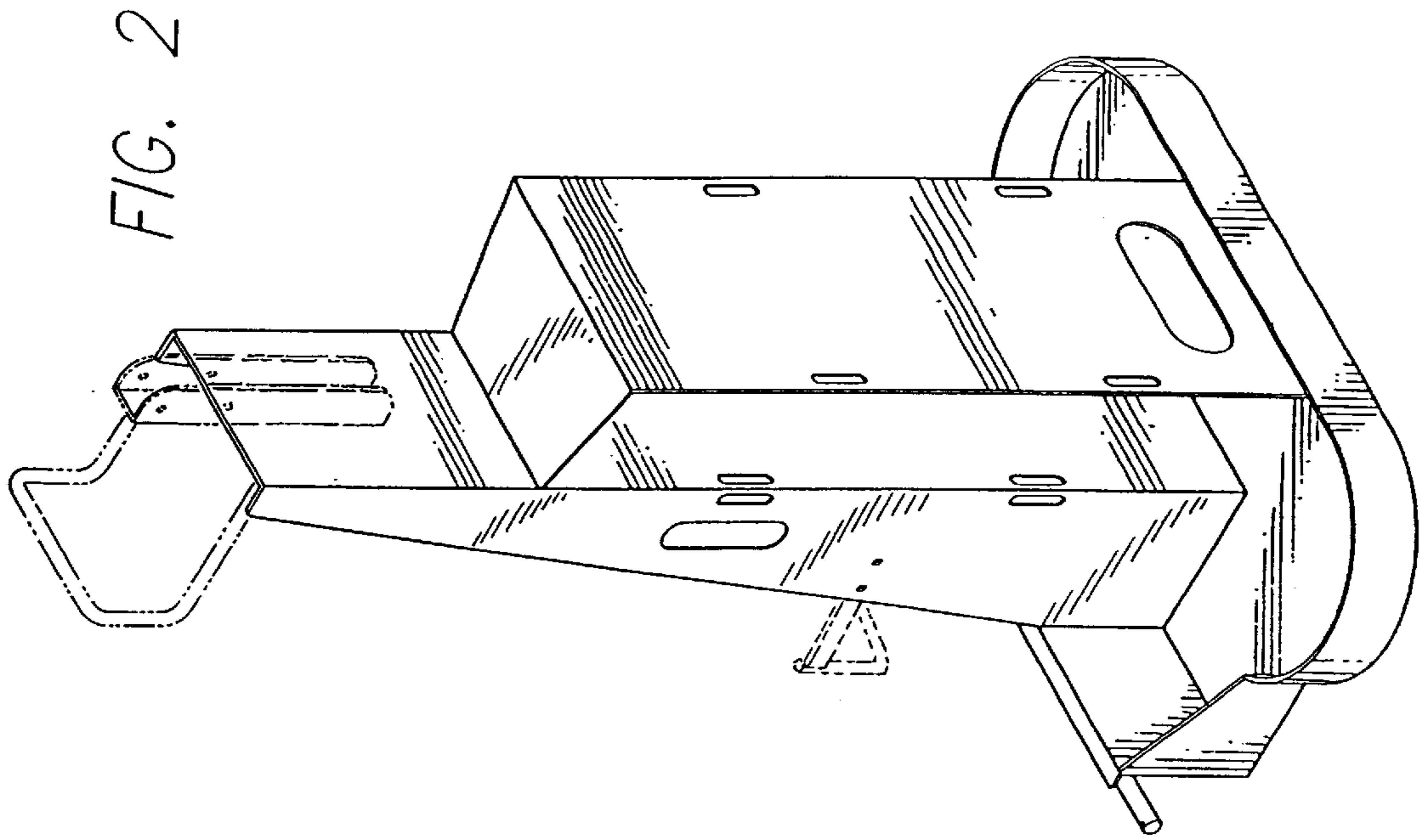

FIG. 3

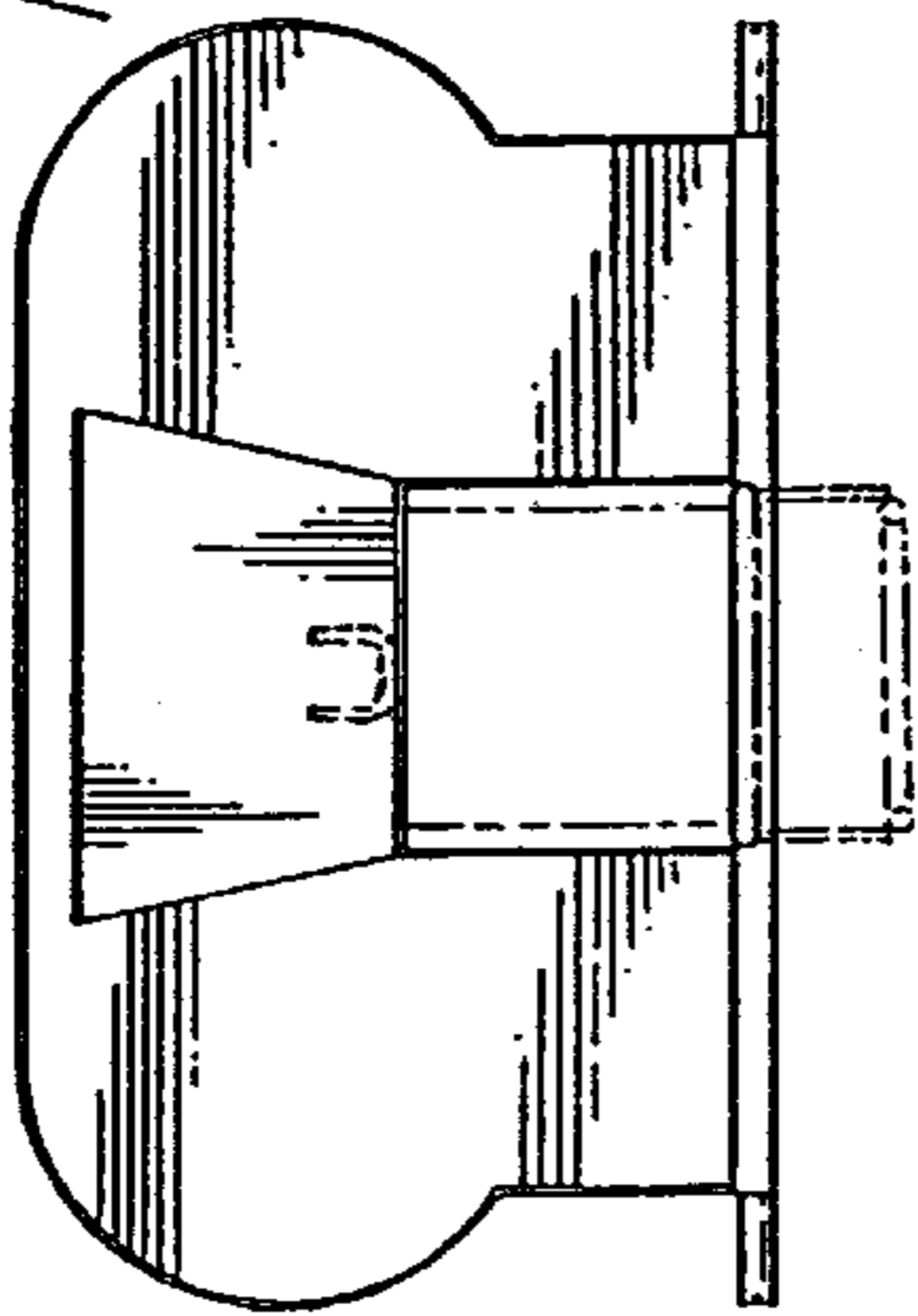

FIG. 4

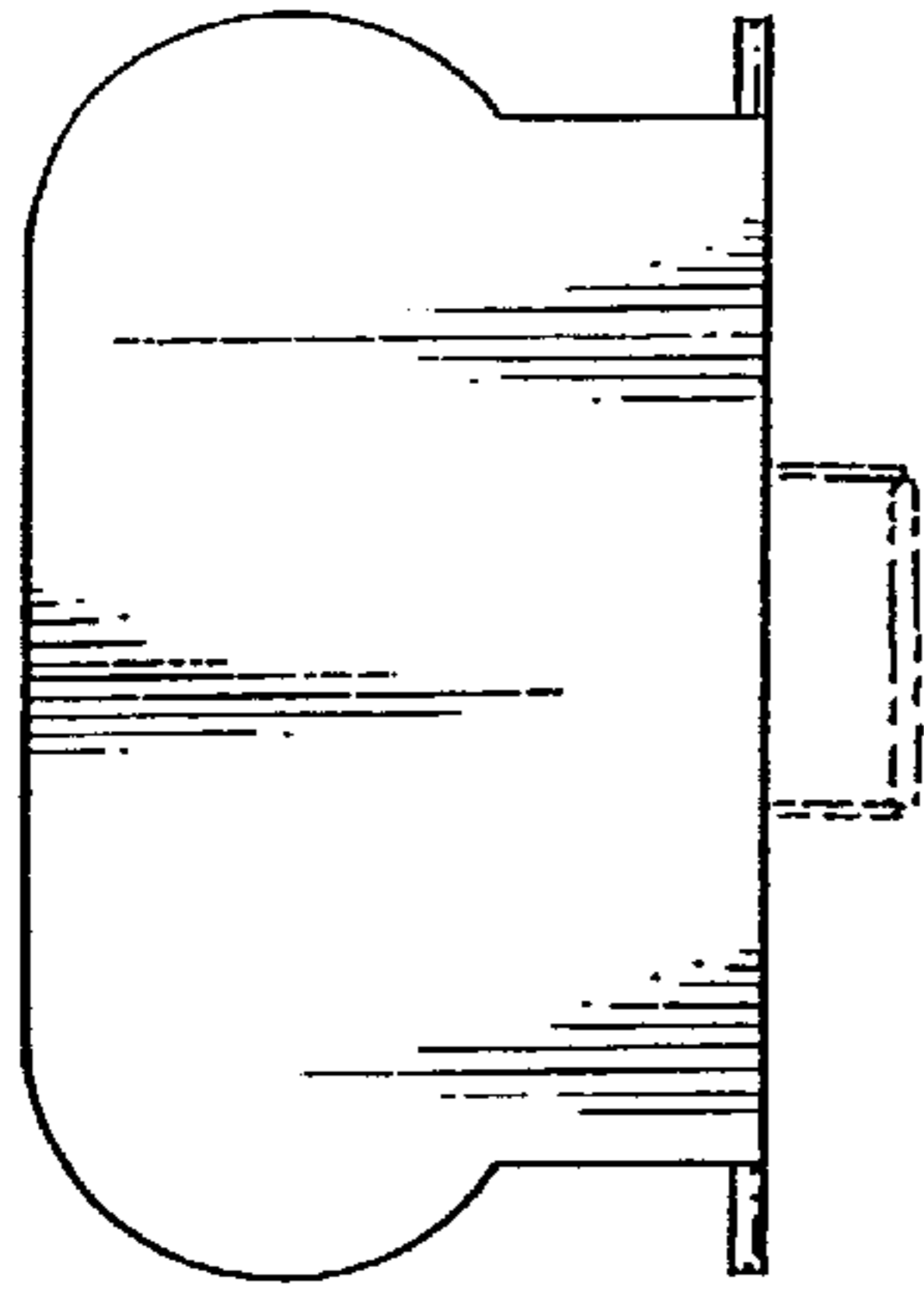

FIG. 6

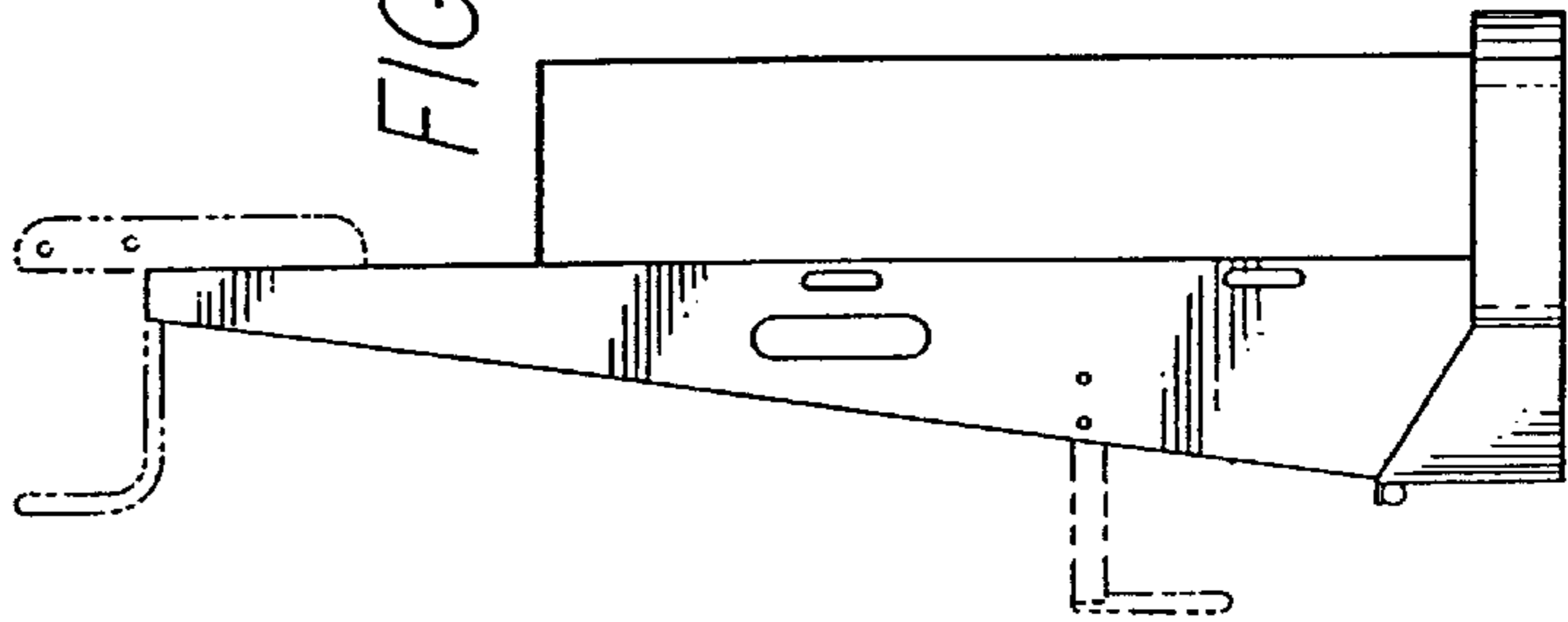

FIG. 5

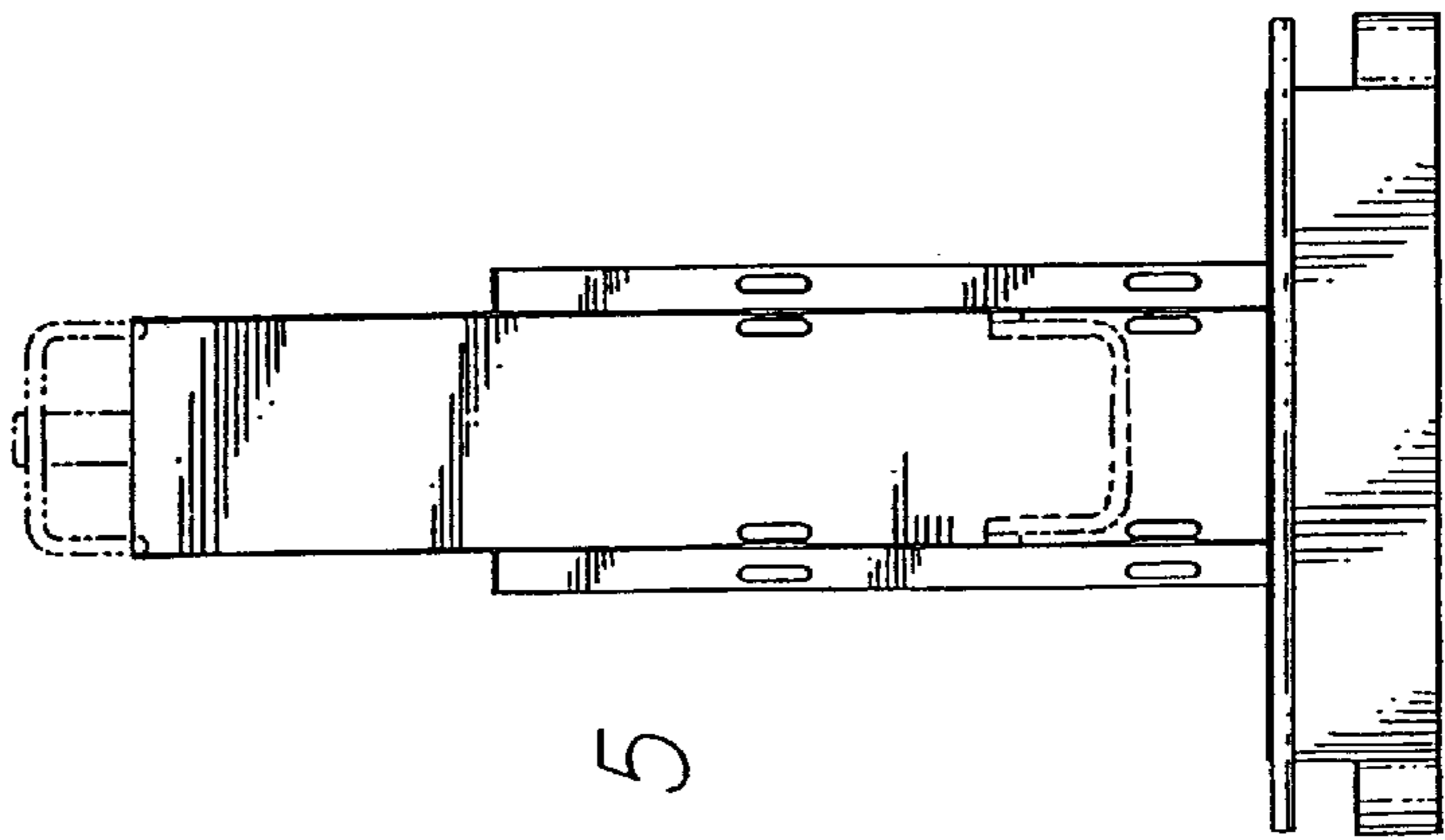

FIG. 7

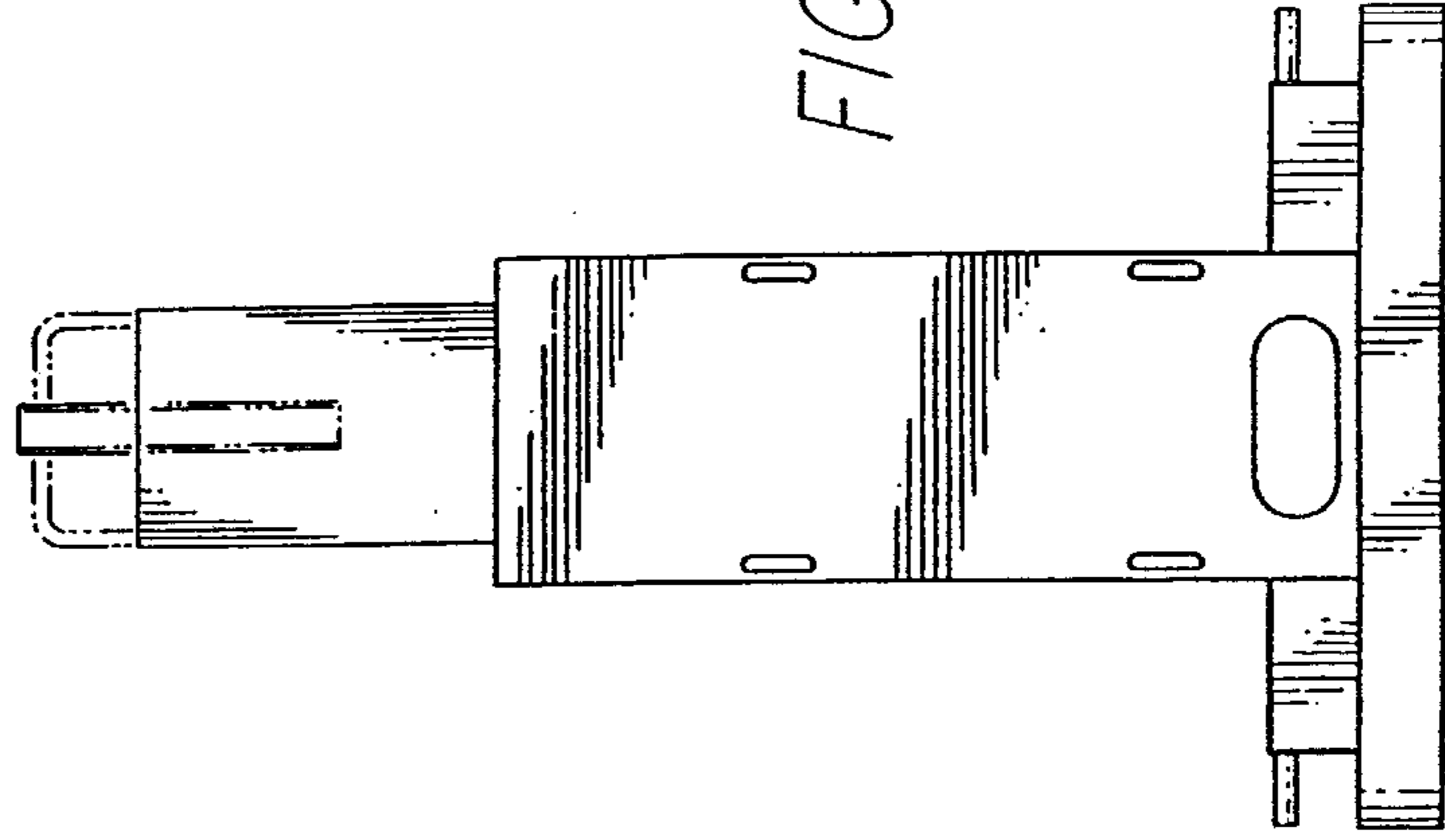

FIG. 9

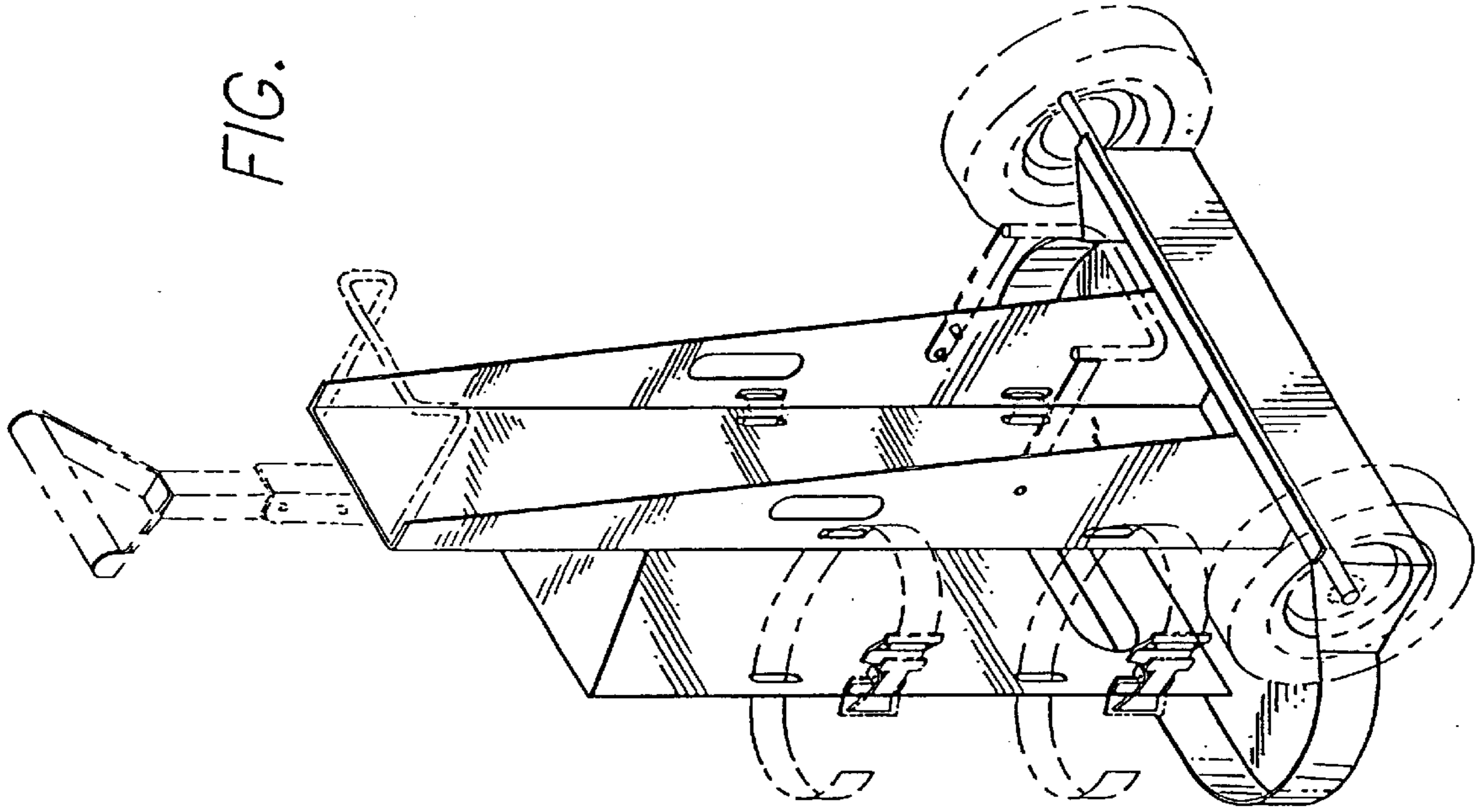

FIG. 8

