



US00D443571S

(12) **United States Design Patent**
DiGiovanni et al.

(10) **Patent No.:** **US D443,571 S**
(45) **Date of Patent:** **** Jun. 12, 2001**

(54) **STEERING TILLER FOR PERSONAL MOBILITY VEHICLE**

(75) Inventors: **Anthony P. DiGiovanni**, DeLand, FL (US); **Michael J. Flowers**, Mantua; **George G. Flowers**, Woodbury Heights, both of NJ (US); **Lee J. Faljoust**, Hatboro, PA (US); **Lee Volpe**, Voorhees, NJ (US)

(73) Assignee: **Electric Mobility Corporation**, Sewell, NJ (US)

(**) Term: **14 Years**

(21) Appl. No.: **29/113,128**

(22) Filed: **Oct. 29, 1999**

(51) **LOC (7) Cl.** **12-16**

(52) **U.S. Cl.** **D12/175**

(58) **Field of Search** D12/175, 16, 1, D12/185, 174; 56/249, 255, 295; 200/61.54

(56) **References Cited**

U.S. PATENT DOCUMENTS

- D. 377,325 * 1/1997 Brown et al. D12/16
- D. 389,491 * 1/1998 Wolf D12/175 X
- D. 389,782 * 1/1998 Scott et al. D12/16

* cited by examiner

Primary Examiner—Melody N. Brown

(74) *Attorney, Agent, or Firm*—Frijouf, Rust & Pyle, P.A.

(57) **CLAIM**

The ornamental design for a steering tiller for personal mobility vehicle, as shown and described.

DESCRIPTION

FIG. 1 is a left side view of our new design for a steering

tiller for personal mobility vehicle shown in a operating position with the personal mobility vehicle being shown in phantom;

FIG. 2 is view similar to FIG. 1 with the steering tiller for personal mobility vehicle being shown in an open position;

FIG. 3 is view similar to FIG. 1 with the steering tiller for personal mobility vehicle being shown in a first operating position;

FIG. 4 is view similar to FIG. 1 with the steering tiller for personal mobility vehicle being shown in a second operating position;

FIG. 5 is an enlarged left side view of our new design for a steering tiller for personal mobility vehicle;

FIG. 6 is a front view thereof;

FIG. 7 is a right side view thereof;

FIG. 8 is a rear view thereof;

FIG. 9 is an enlarged top view of FIG. 7;

FIG. 10 is an enlarged bottom view of FIG. 7;

FIG. 11 is view similar to FIG. 5 with the steering tiller for personal mobility vehicle being shown in the open position;

FIG. 12 is a front view thereof;

FIG. 13 is a right side view thereof;

FIG. 14 is a rear view thereof;

FIG. 15 is an enlarged top view of FIG. 13; and,

FIG. 16 is an enlarged bottom view of FIG. 13.

The portions of the vehicle shown in broken lines throughout the drawing views are for illustrative purposes only and form no part of the claimed design.

1 Claim, 8 Drawing Sheets

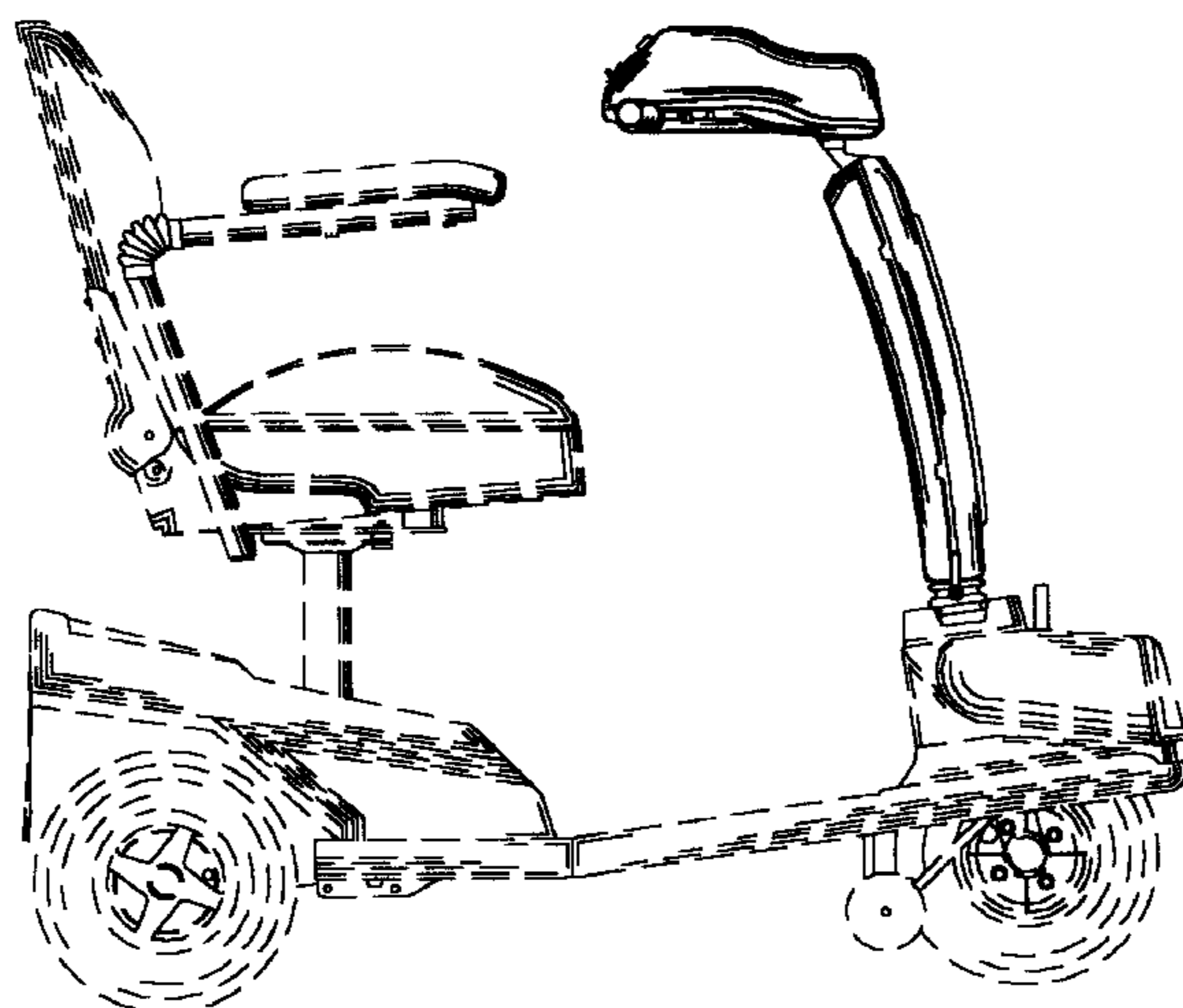

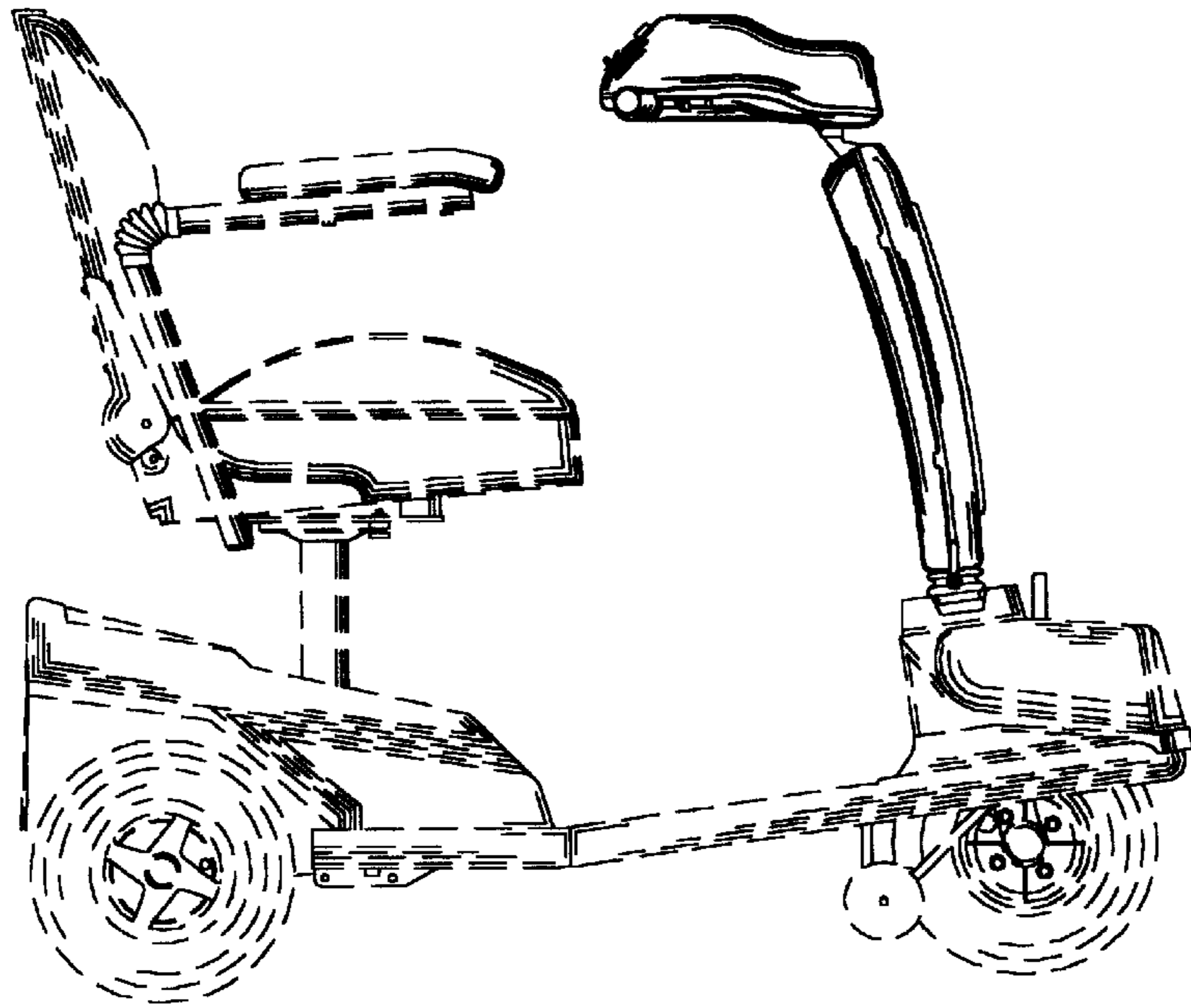

FIG. 1

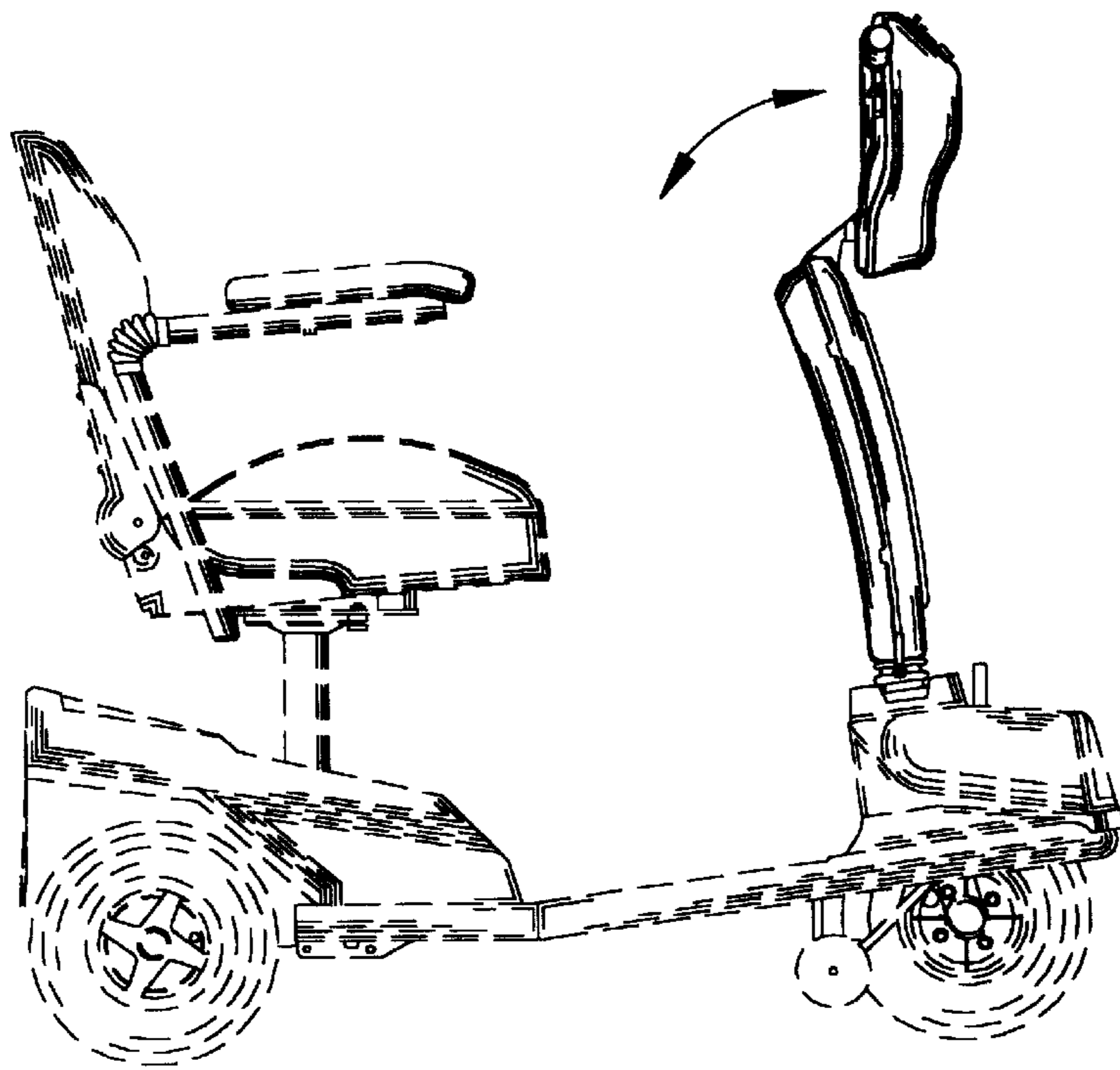

FIG. 2

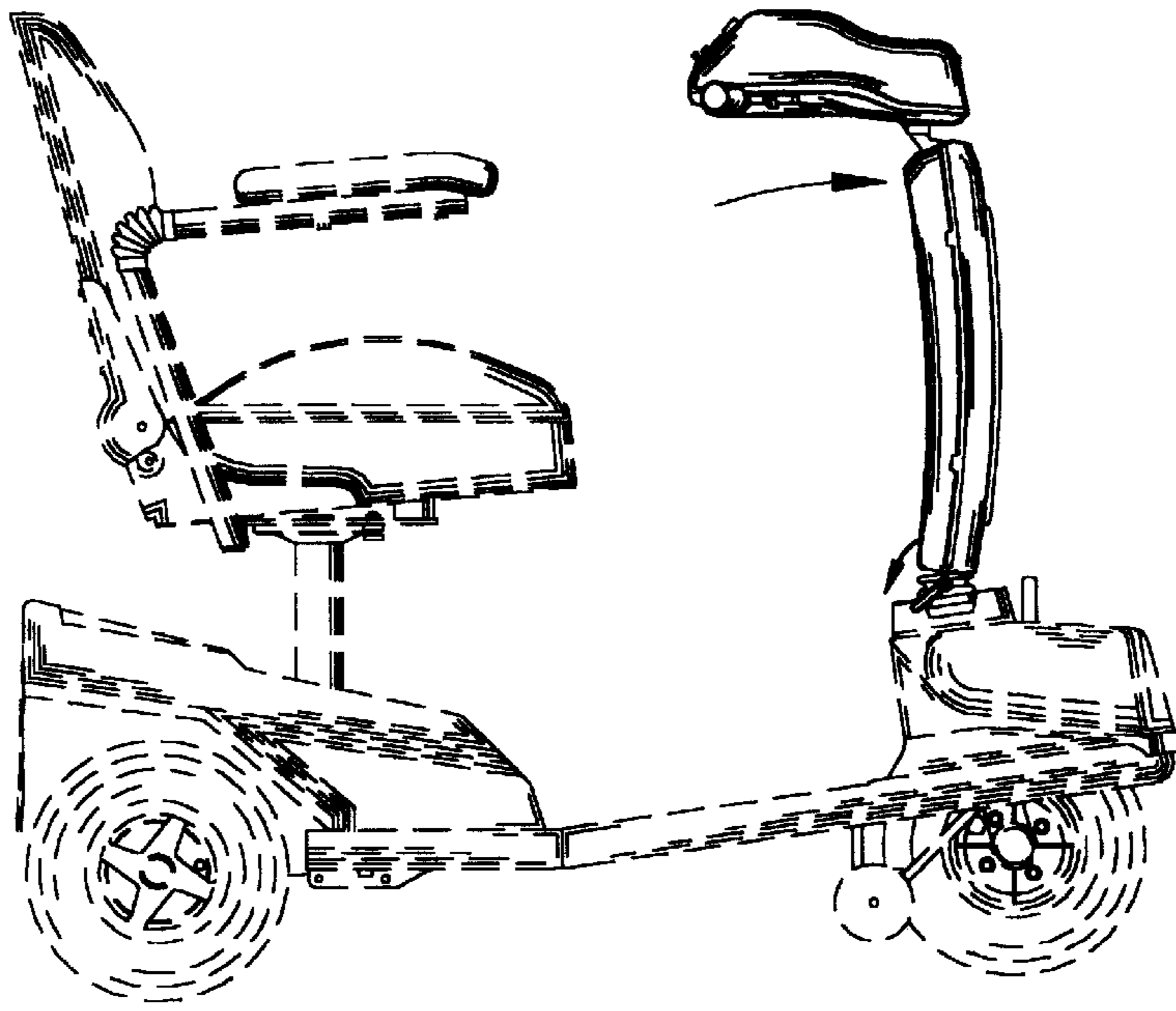

FIG. 3

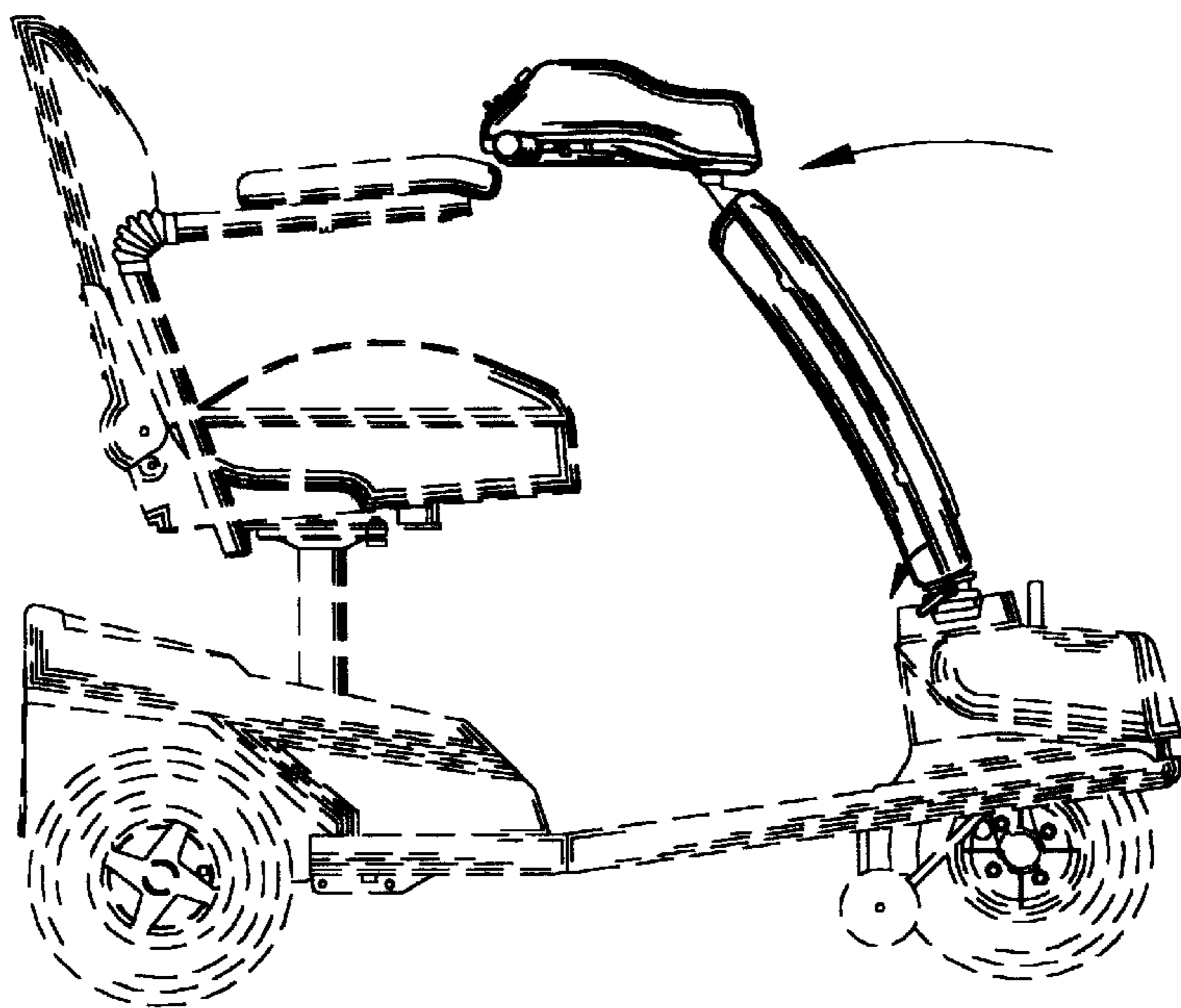

FIG. 4

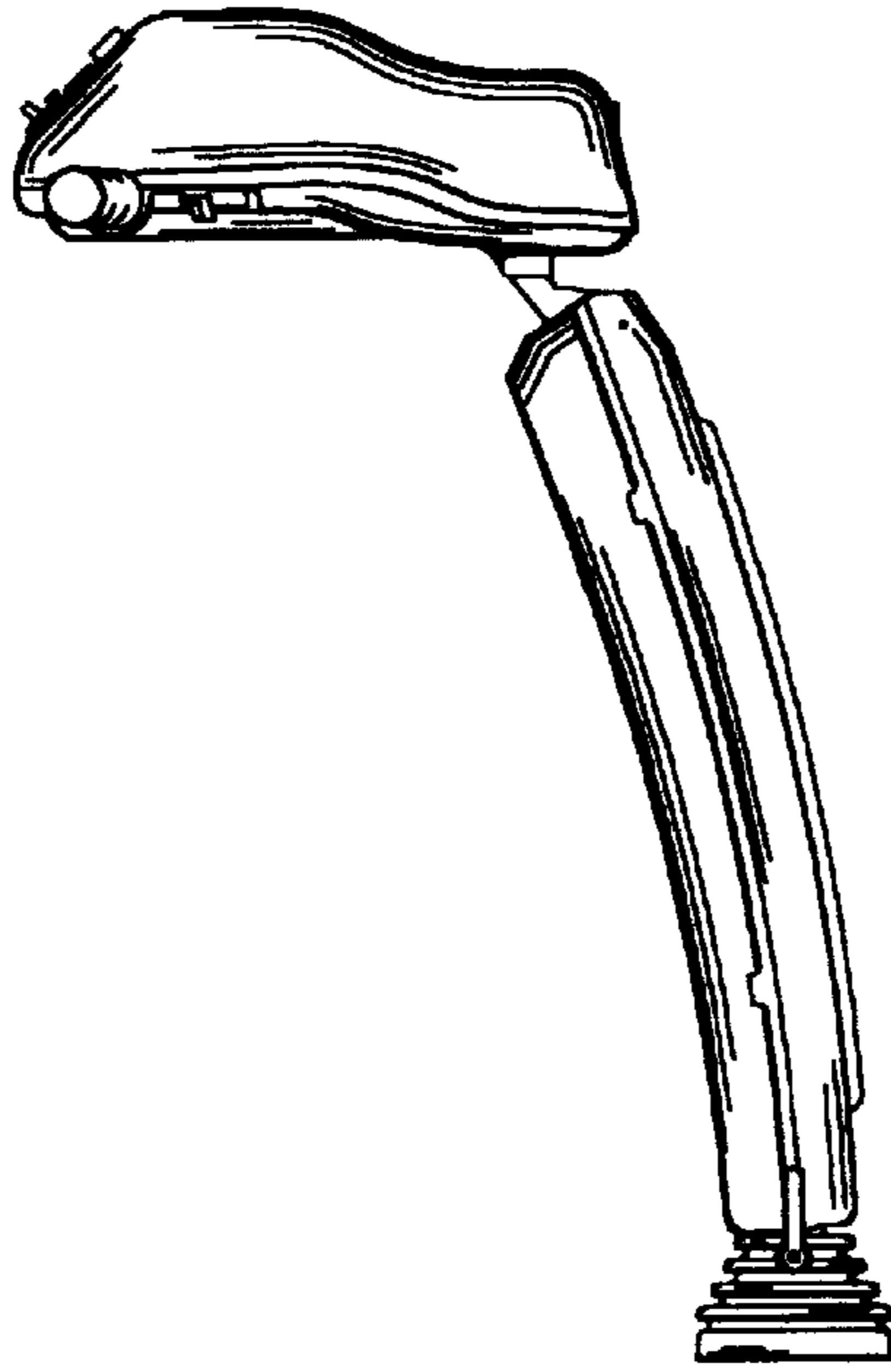

FIG. 5

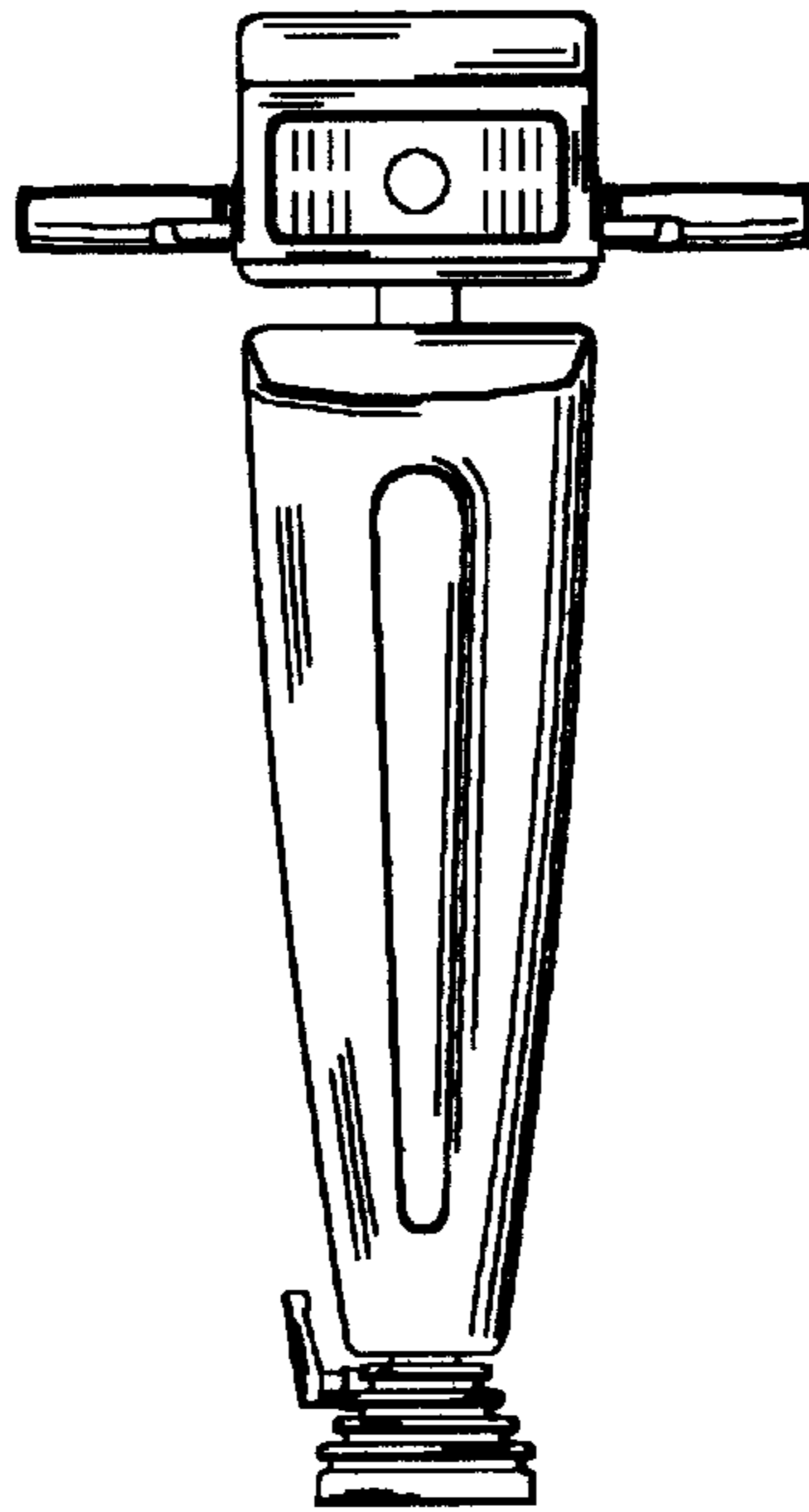

FIG. 6

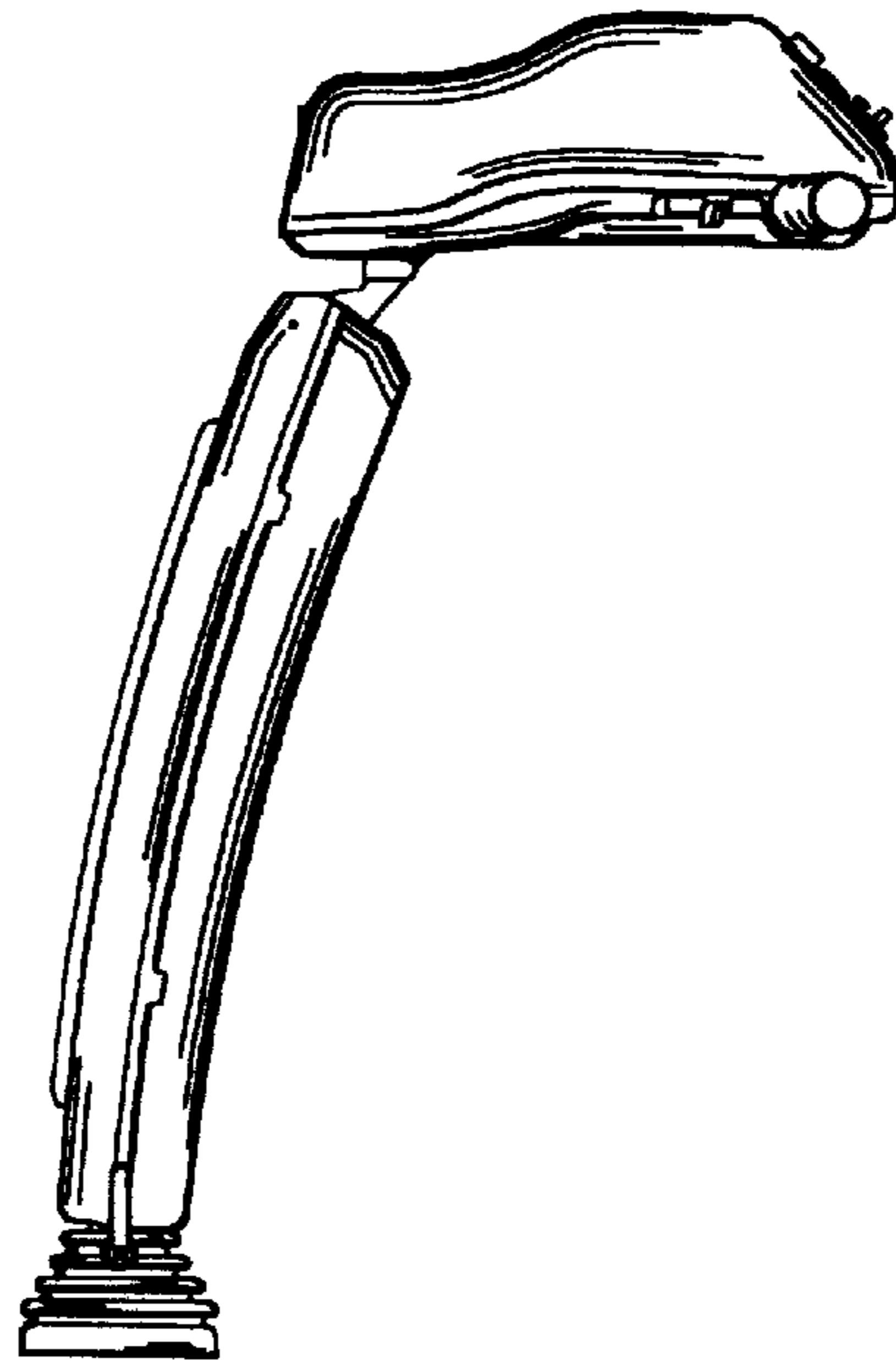

FIG. 7

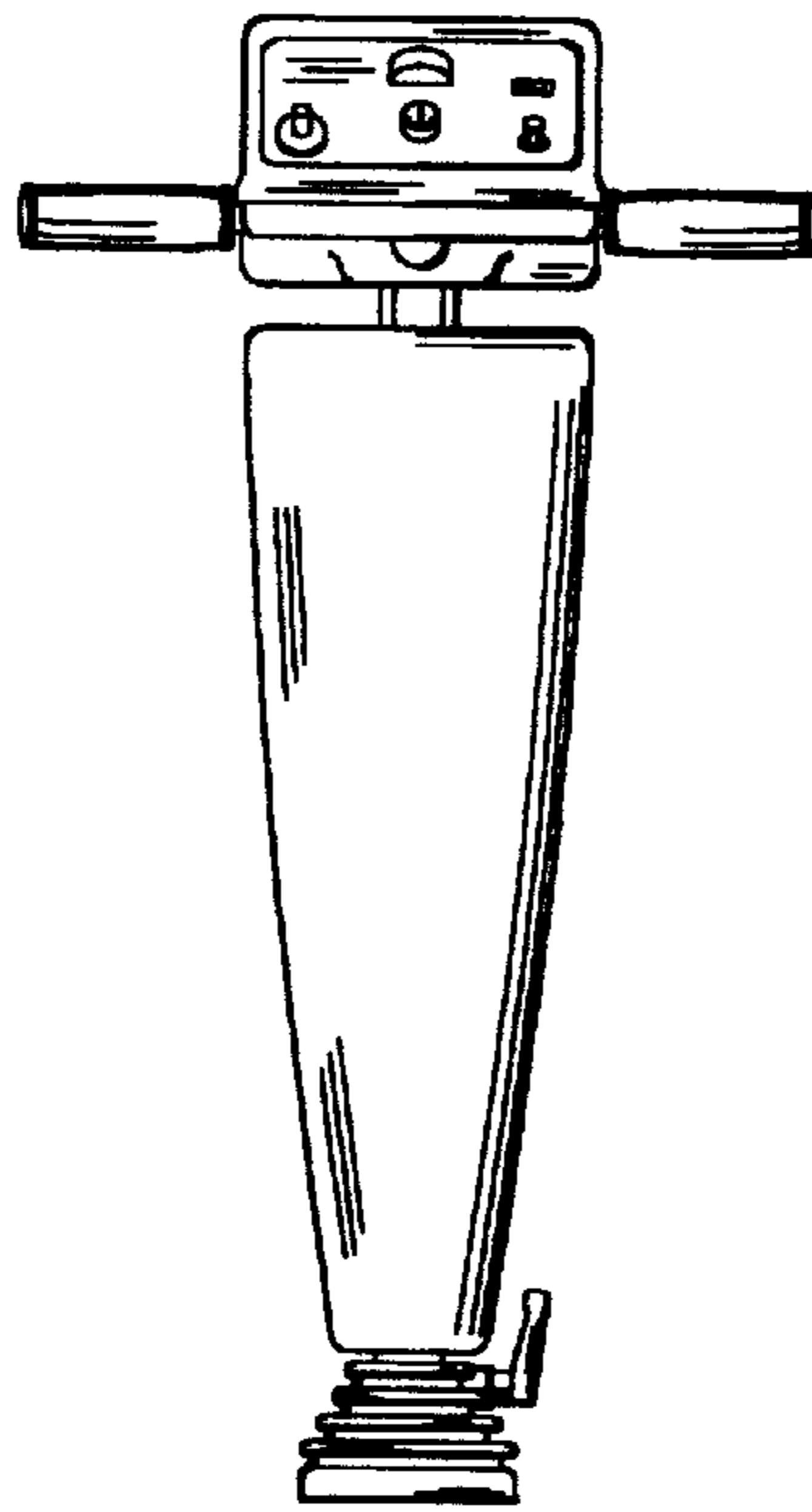

FIG. 8

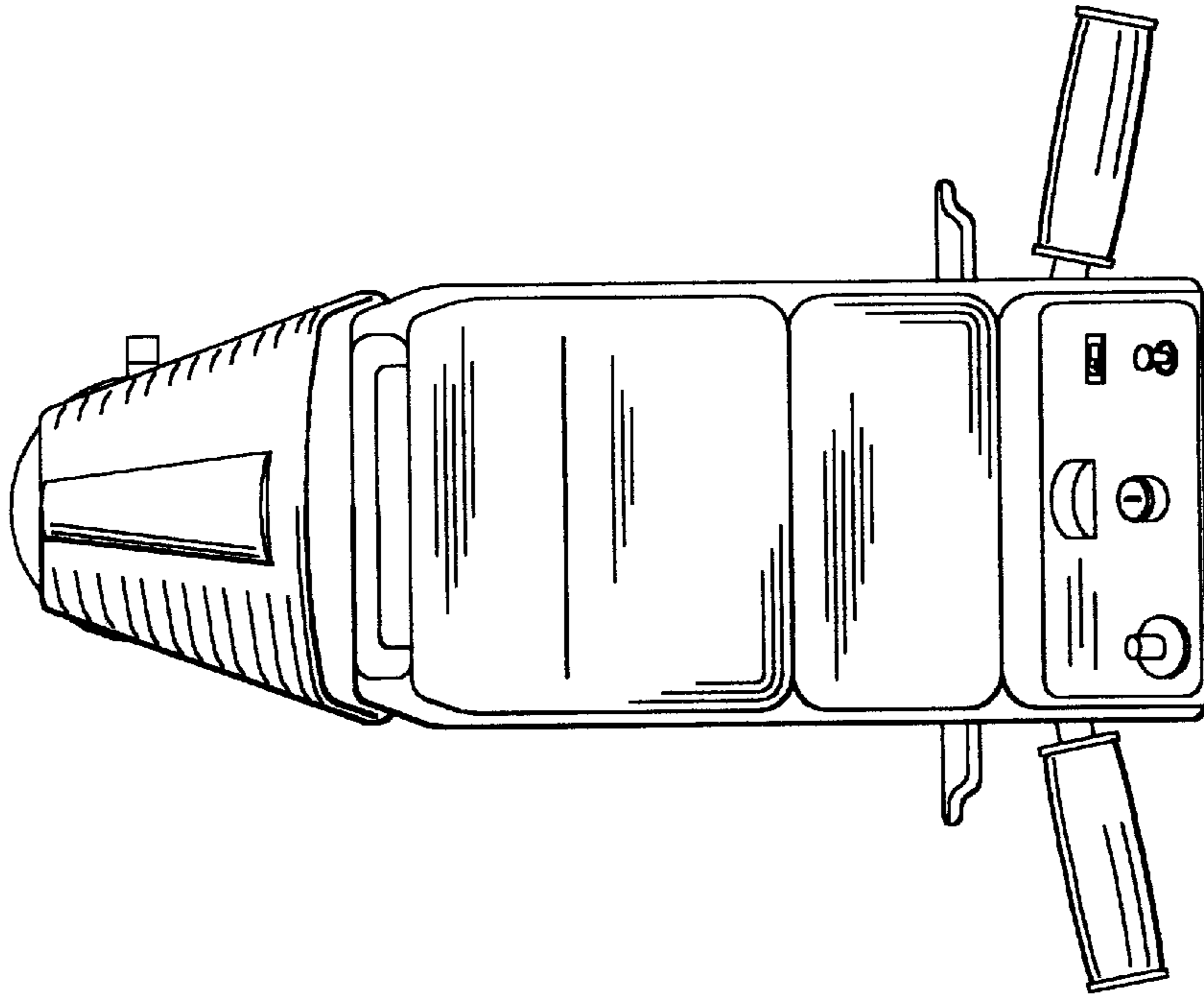

FIG. 9

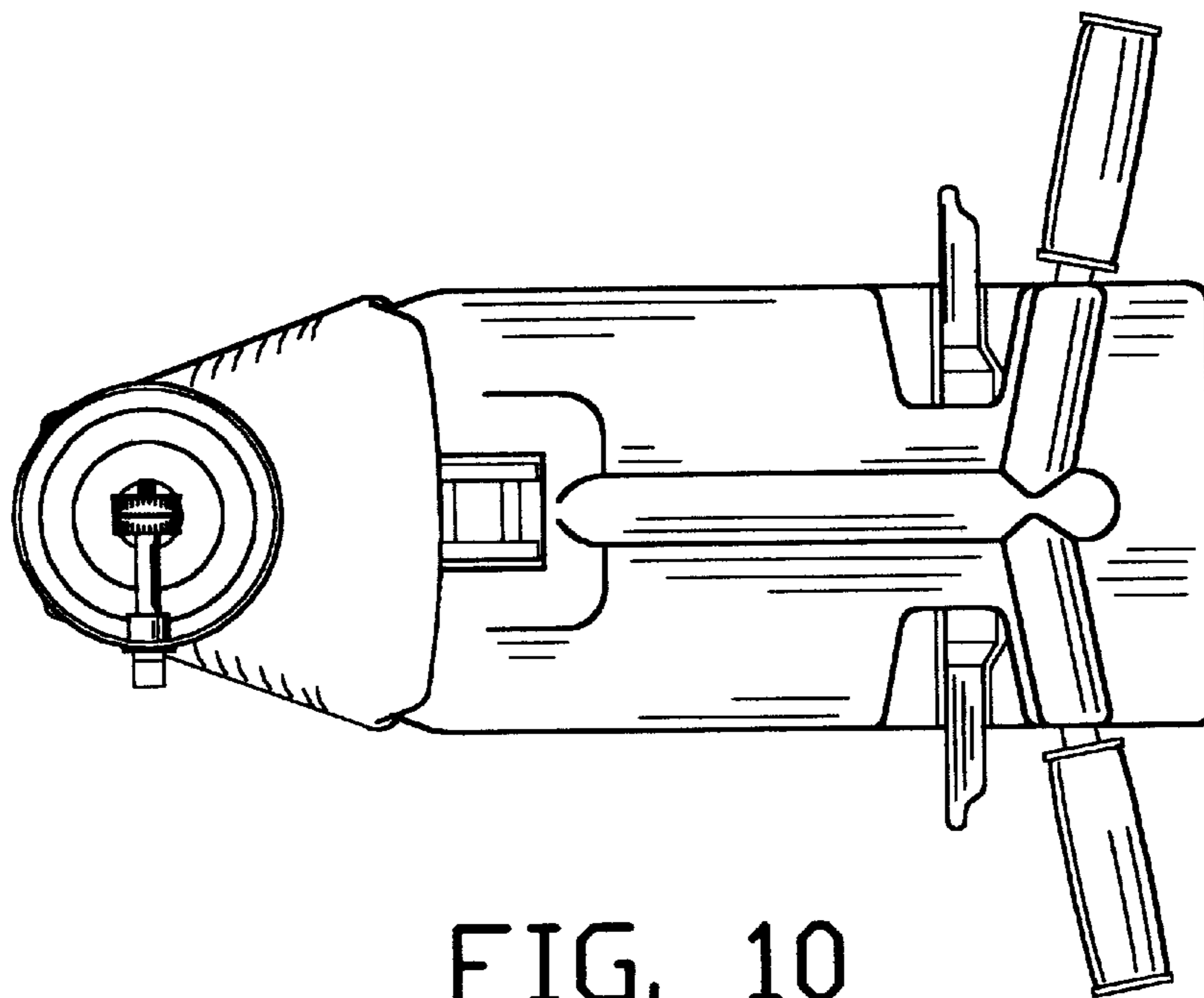

FIG. 10

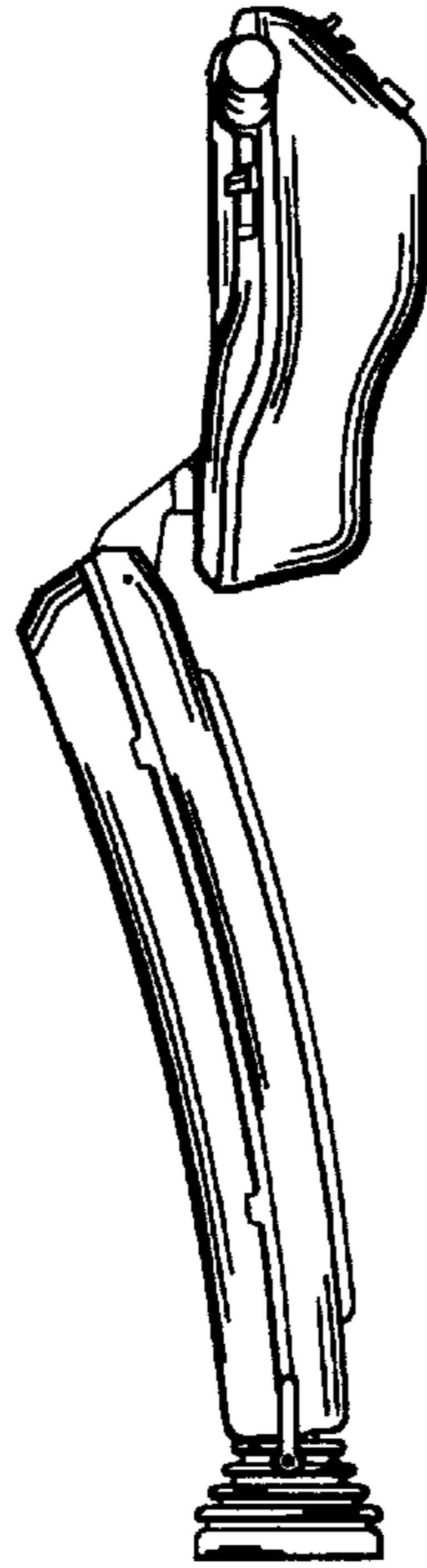

FIG. 11

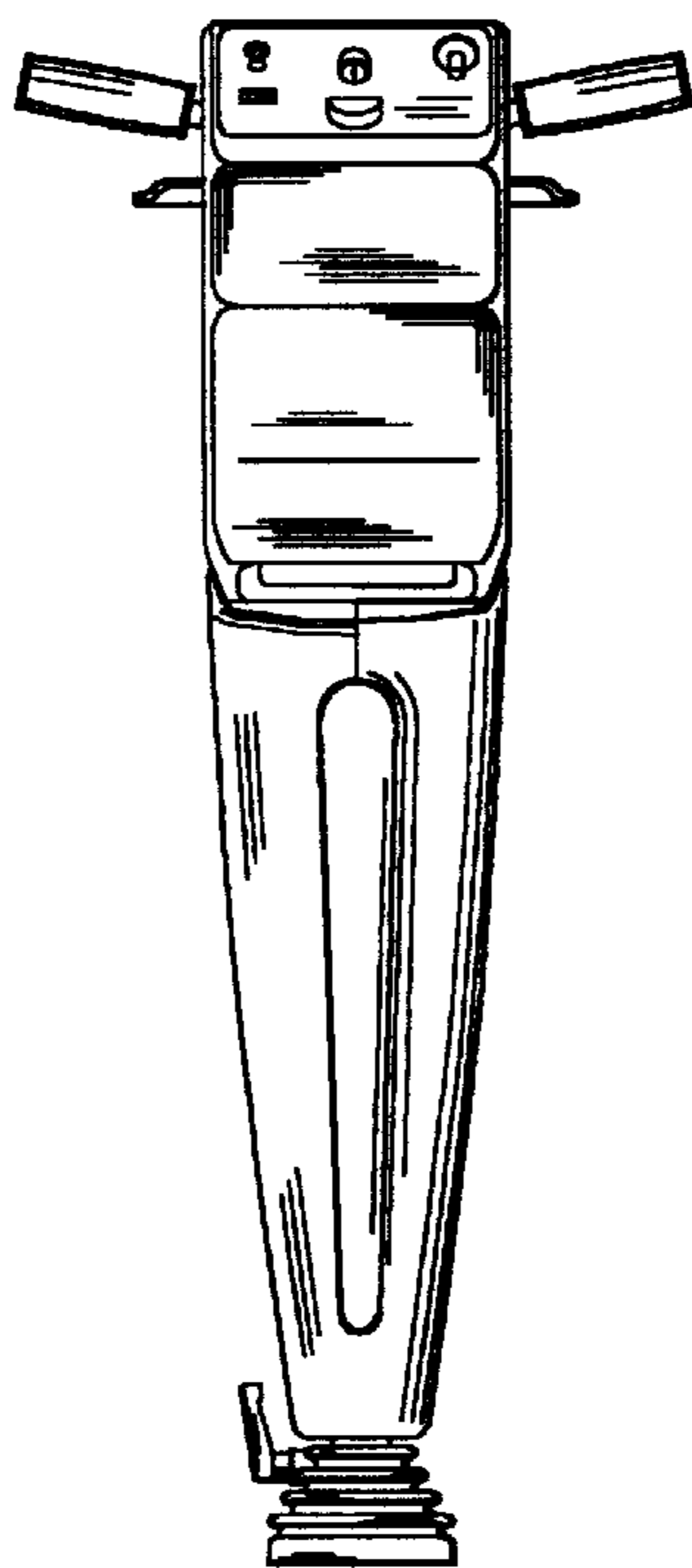

FIG. 12

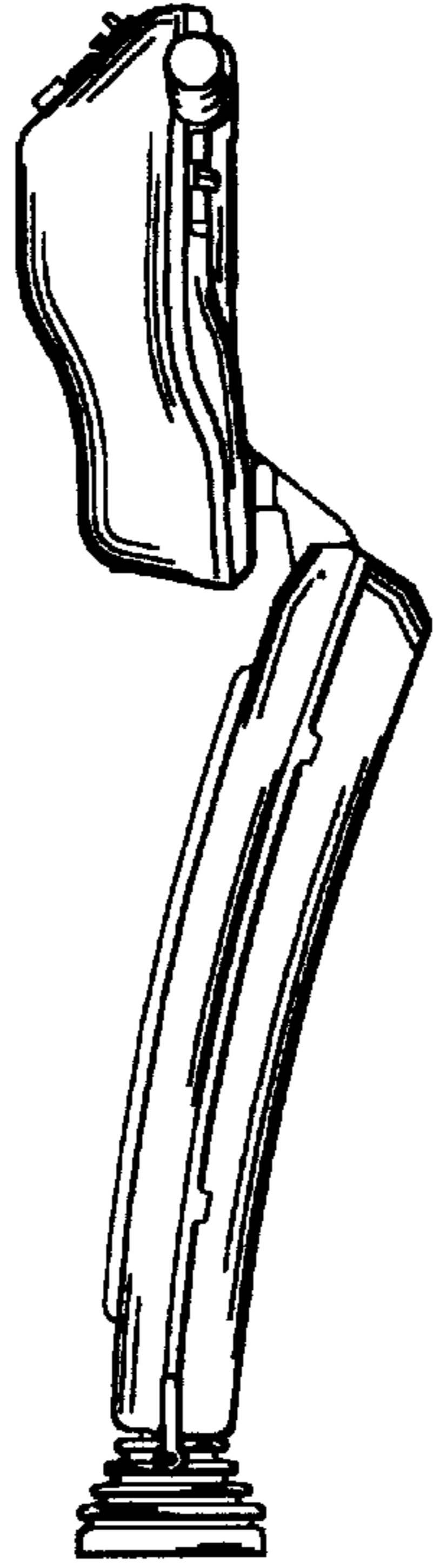

FIG. 13

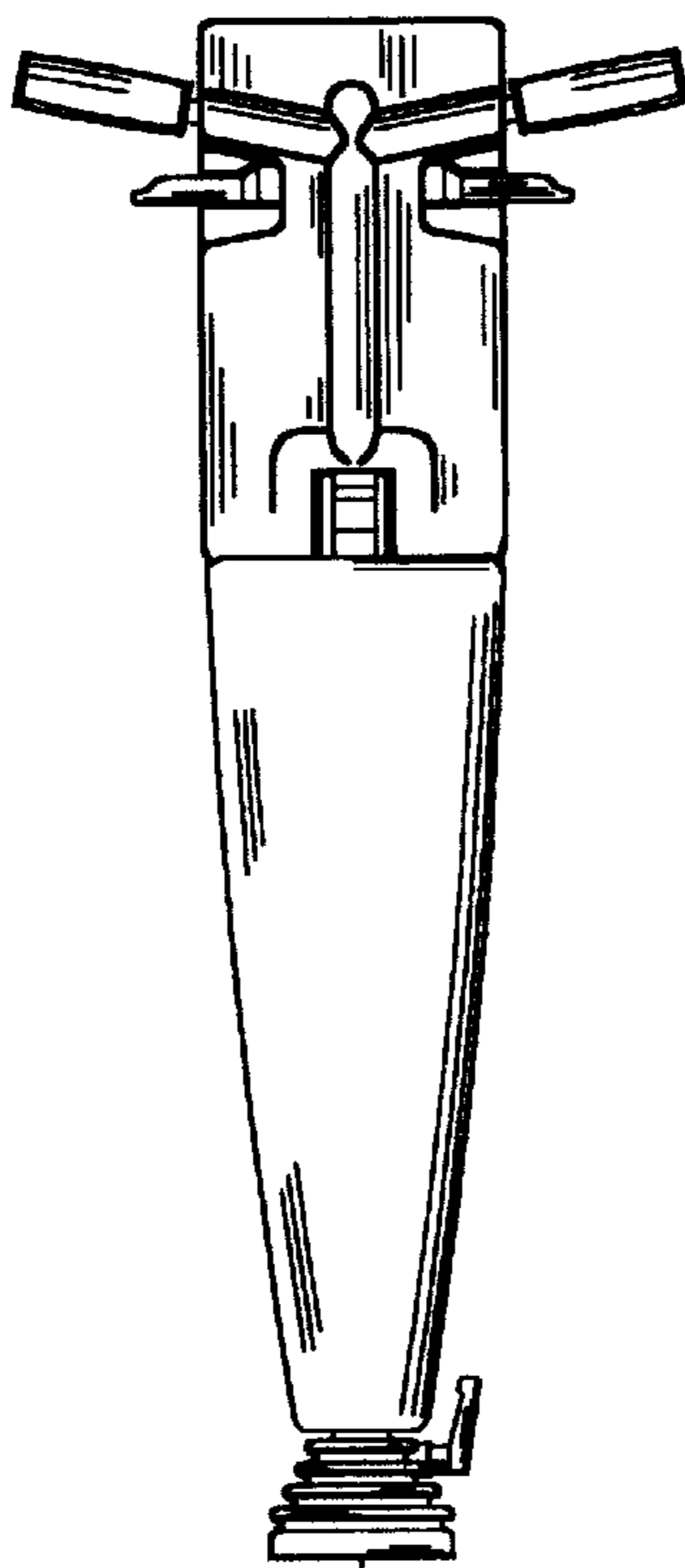

FIG. 14

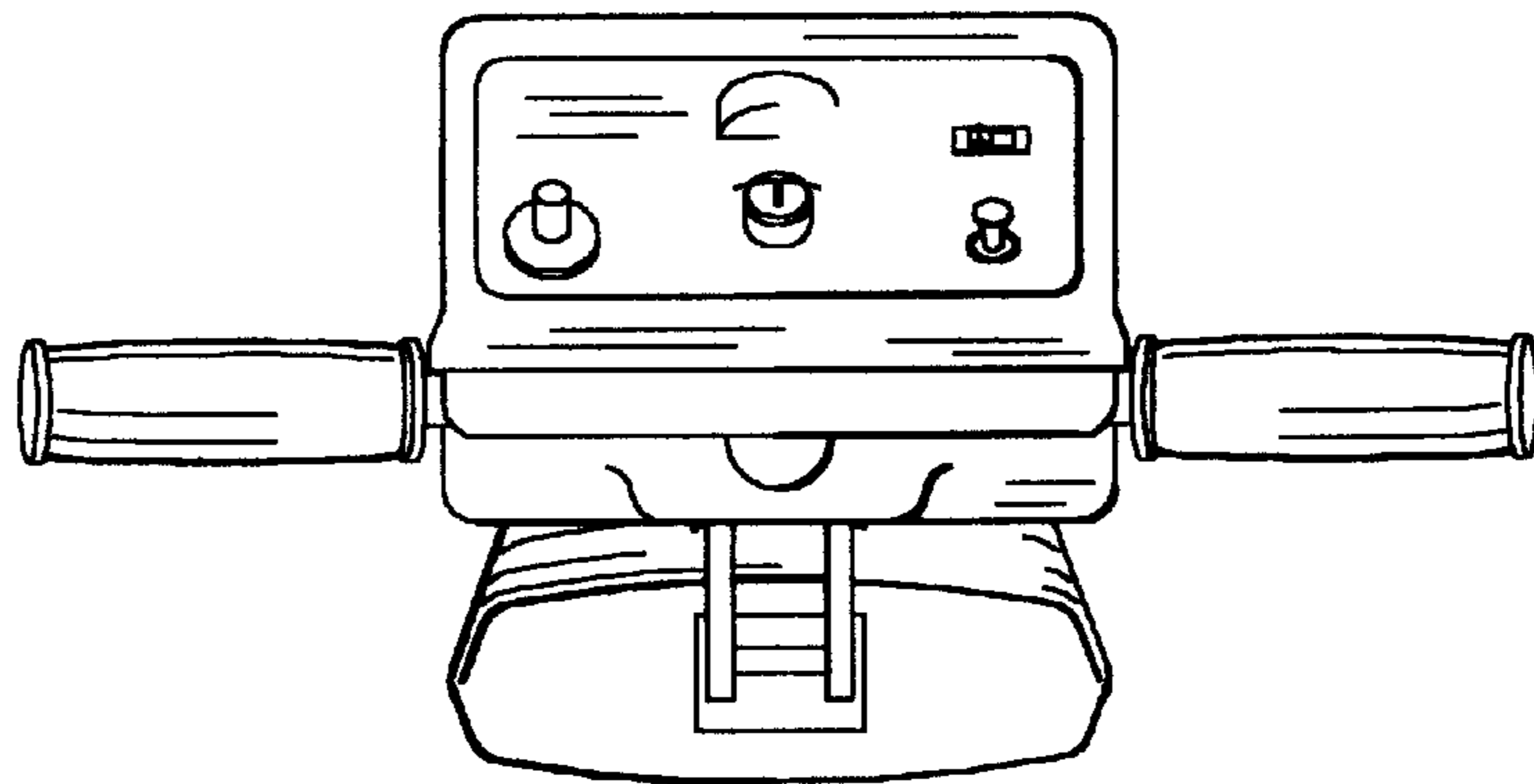

FIG. 15

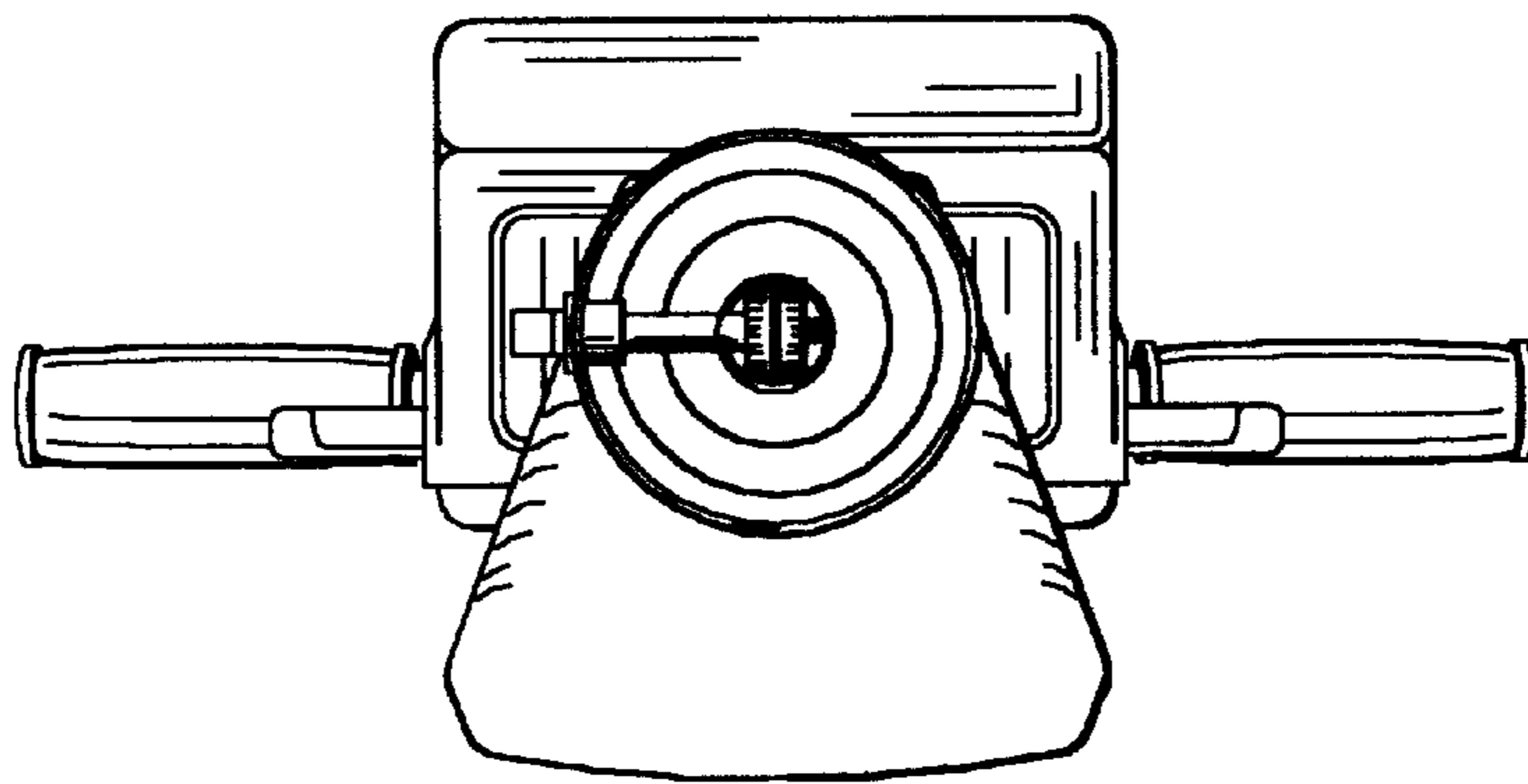

FIG. 16