



US00D443172S

(12) **United States Design Patent**
Taira

(10) **Patent No.:** **US D443,172 S**

(45) **Date of Patent:** **** Jun. 5, 2001**

(54) **MICROWAVE OVEN**

(75) **Inventor:** **Tomoki Taira, Osaka-fu (JP)**

(73) **Assignee:** **Sharp Kabushiki Kaisha, Osaka (JP)**

(*) **Notice:** This patent is subject to a terminal disclaimer.

(**) **Term:** **14 Years**

(21) **Appl. No.:** **29/121,594**

(22) **Filed:** **Apr. 11, 2000**

(30) **Foreign Application Priority Data**

Oct. 12, 1999 (JP) 11-27973

(51) **LOC (7) Cl.** **07-02**

(52) **U.S. Cl.** **D7/351**

(58) **Field of Search** D7/350.1-350.4,
D7/402, 351; 126/273 R, 273 A, 275 R,
275 E, 19 M, 21 A; 219/678, 680, 756-758

(56) **References Cited**

U.S. PATENT DOCUMENTS

- D. 295,356 * 4/1988 Nambu et al. D7/351
- D. 305,596 * 1/1990 Nishibori D7/351
- D. 305,600 * 1/1990 Iwahashi D7/351
- D. 305,856 * 2/1990 Iwahashi D7/351
- D. 305,970 * 2/1990 Nishibori D7/351
- D. 313,919 * 1/1991 Naito et al. D7/351
- D. 329,353 9/1992 Yamada .
- D. 334,688 4/1993 Kitae et al. .
- D. 335,064 4/1993 Sugiyama et al. .
- D. 352,636 11/1994 Nakamura .

- D. 352,866 * 11/1994 Kindley et al. D7/351
- D. 353,510 12/1994 Nakamura .
- D. 353,511 12/1994 Saimen .
- D. 353,512 12/1994 Saimen et al. .
- D. 356,006 3/1995 Saimen et al. .
- D. 357,159 4/1995 Mitsui et al. .
- D. 367,991 3/1996 Saimen .
- D. 367,992 3/1996 Saimen .
- D. 368,405 4/1996 Tada .
- D. 368,406 4/1996 Nakamura .
- D. 372,058 * 7/1996 Yang D21/524
- D. 373,502 9/1996 Fujii et al. .
- D. 390,411 2/1998 Nakagawa .
- D. 390,412 2/1998 Takimoto .
- D. 410,813 6/1999 Fujii .
- D. 410,814 6/1999 Koike .

* cited by examiner

Primary Examiner—Ruth McInroy

(74) *Attorney, Agent, or Firm*—Nixon & Vanderhye

(57) **CLAIM**

The ornamental design for a microwave oven, as shown and described.

DESCRIPTION

FIG. 1 is a top, front and right side perspective view of a microwave oven showing my new design;
FIG. 2 is a top plan view thereof;
FIG. 3 is a front elevational view thereof;
FIG. 4 is a right side elevational view thereof;
FIG. 5 is a left side elevational view thereof;
FIG. 6 is a rear elevational view thereof; and,
FIG. 7 is a bottom plan view thereof.

1 Claim, 4 Drawing Sheets

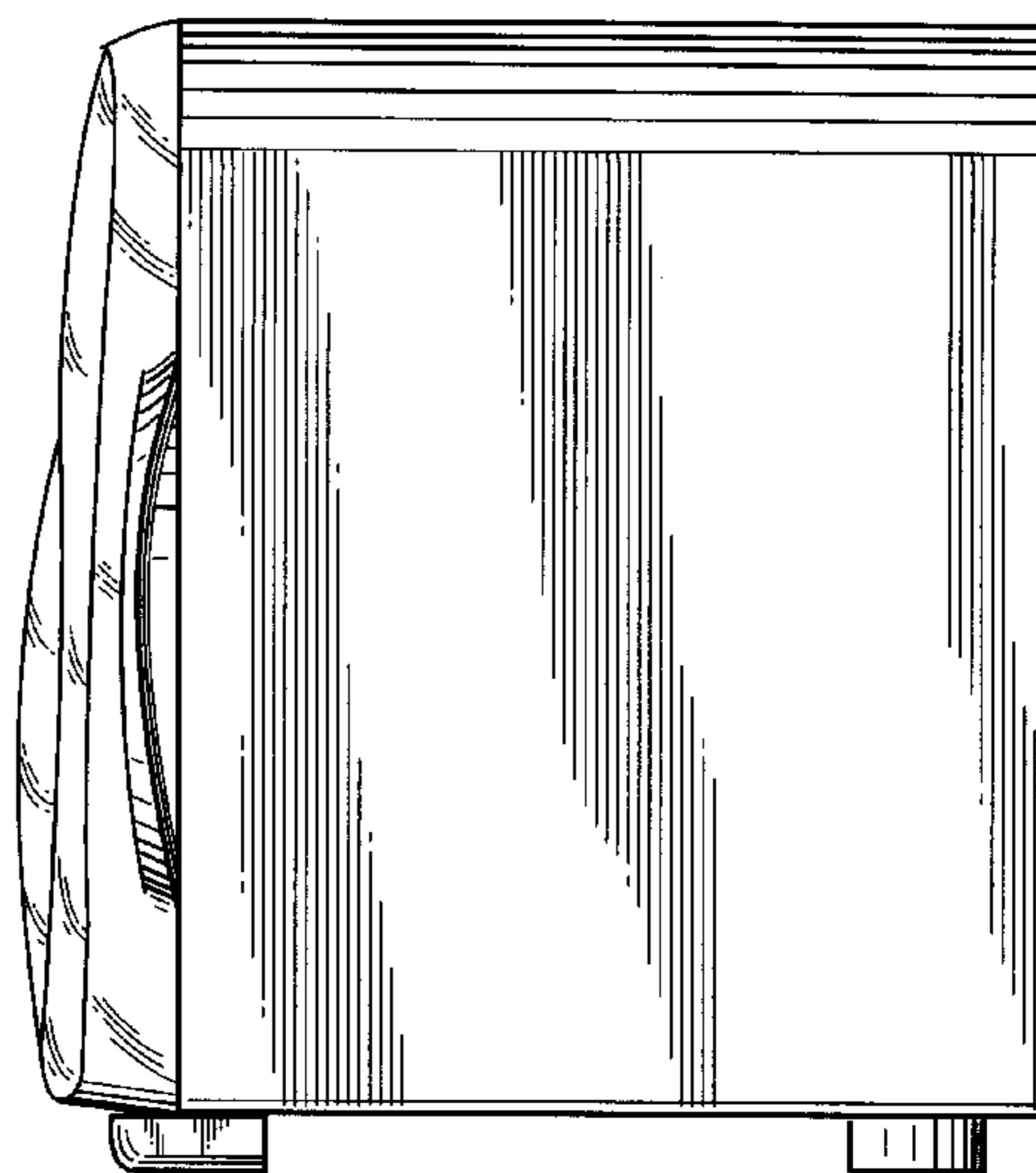
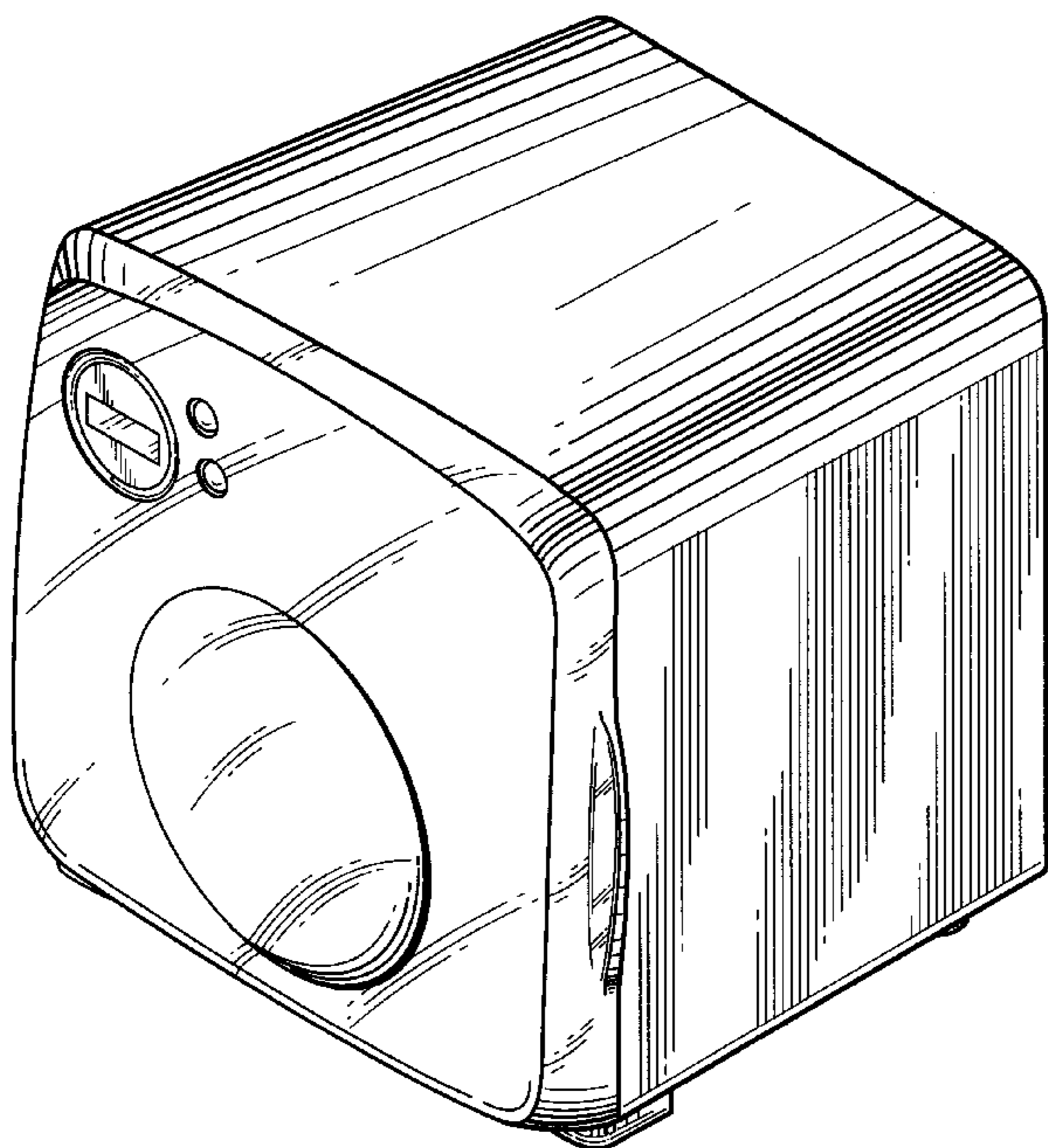

FIG. 1

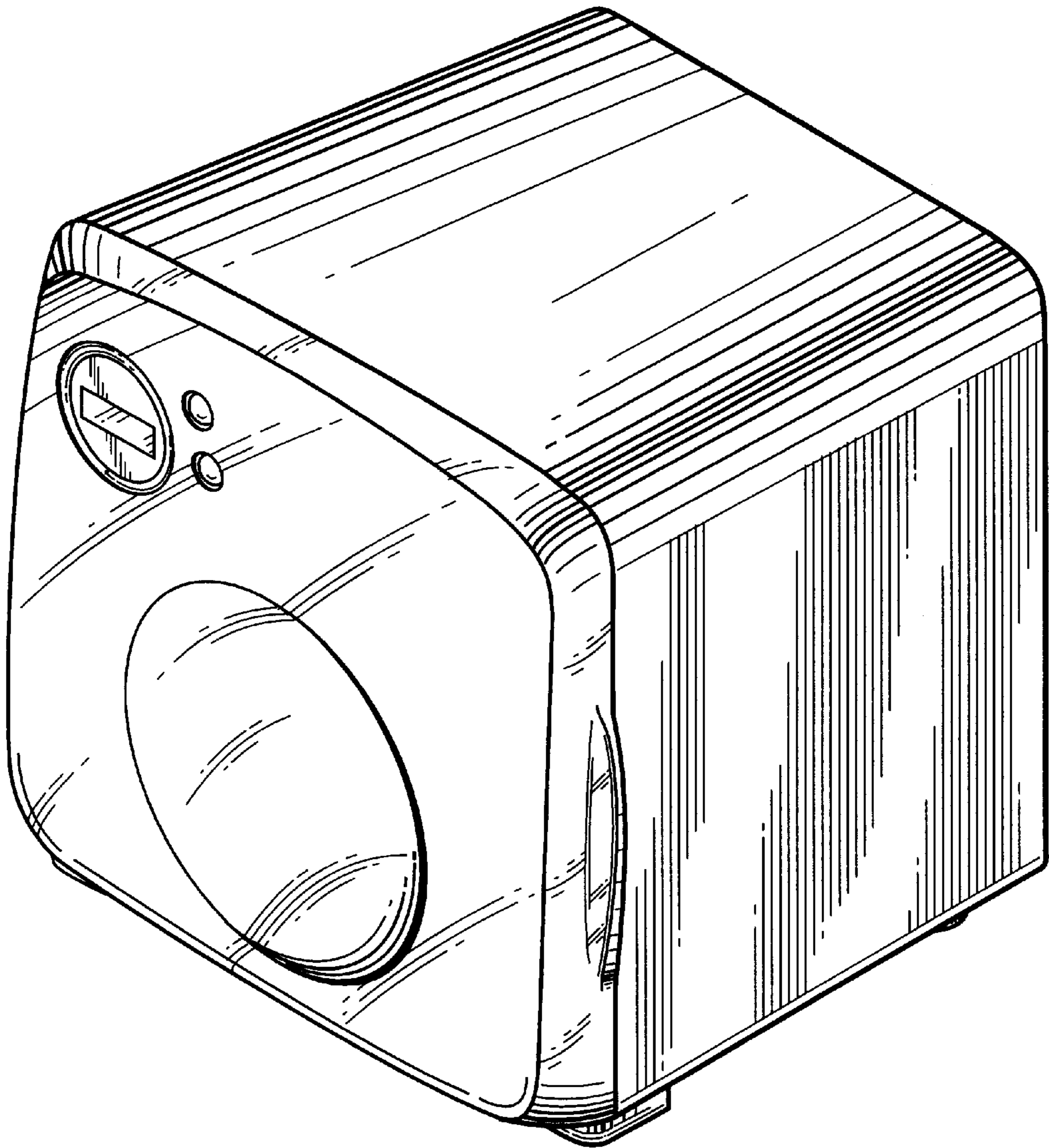

FIG. 2

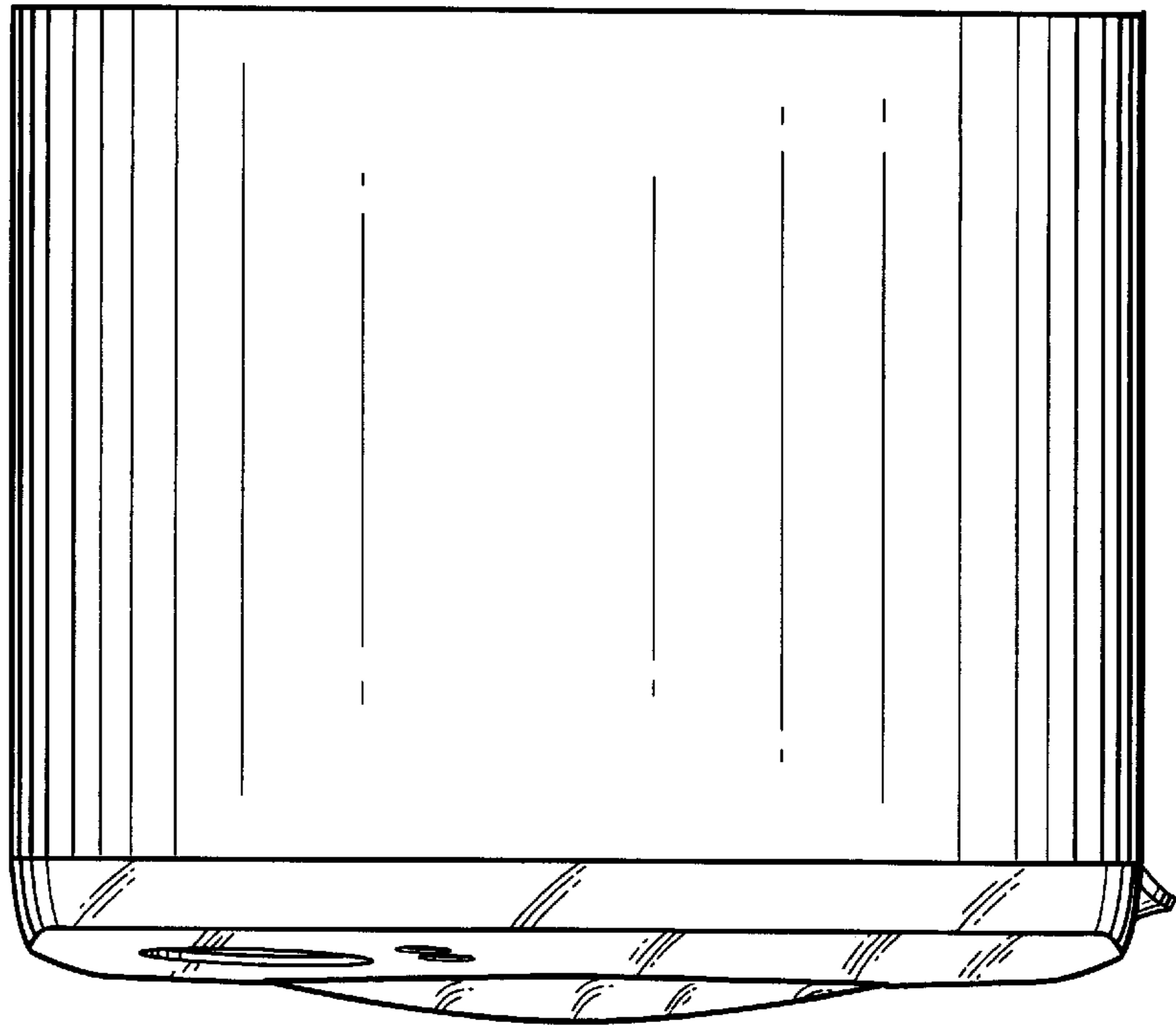

FIG. 3

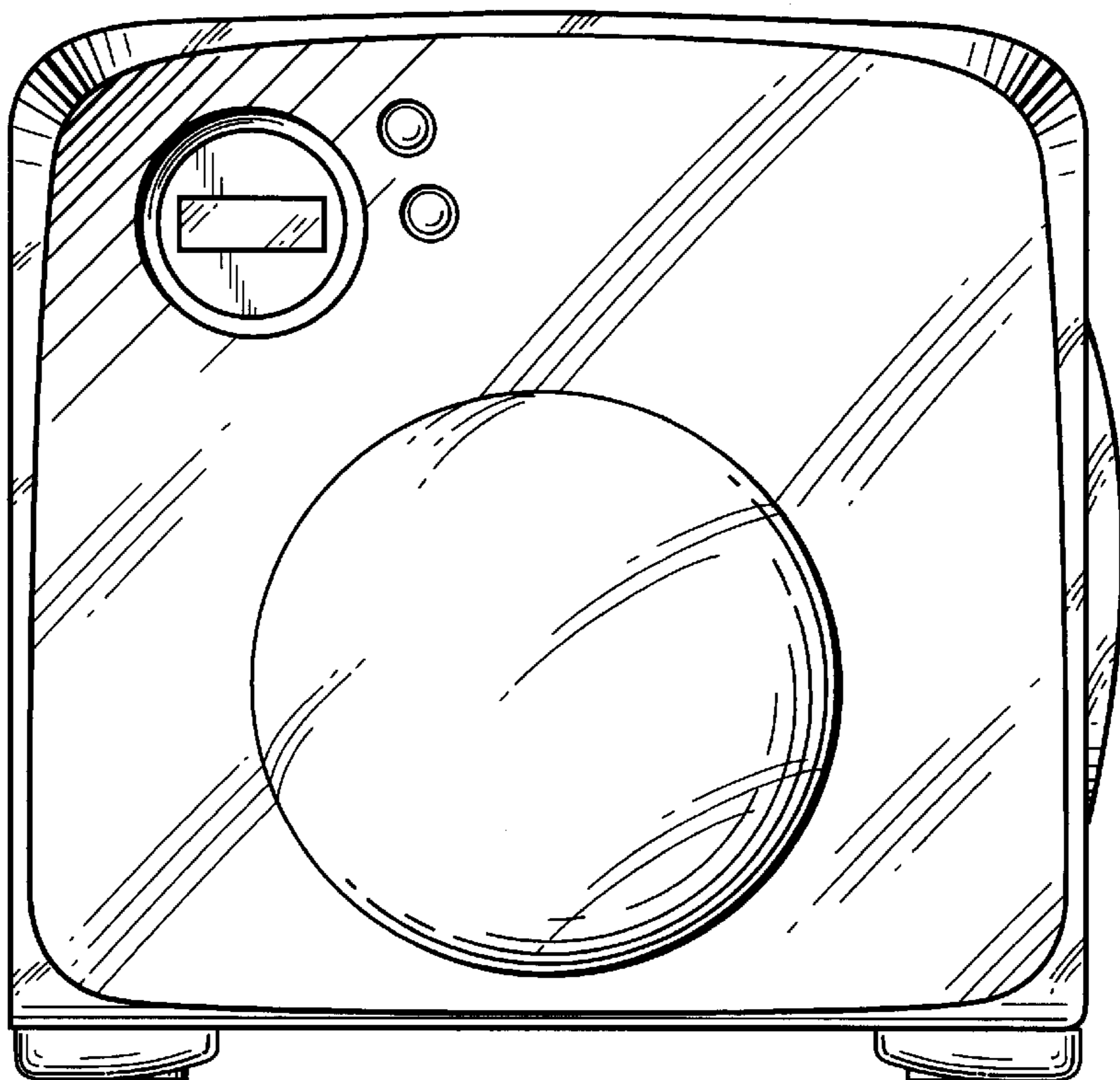

FIG. 4

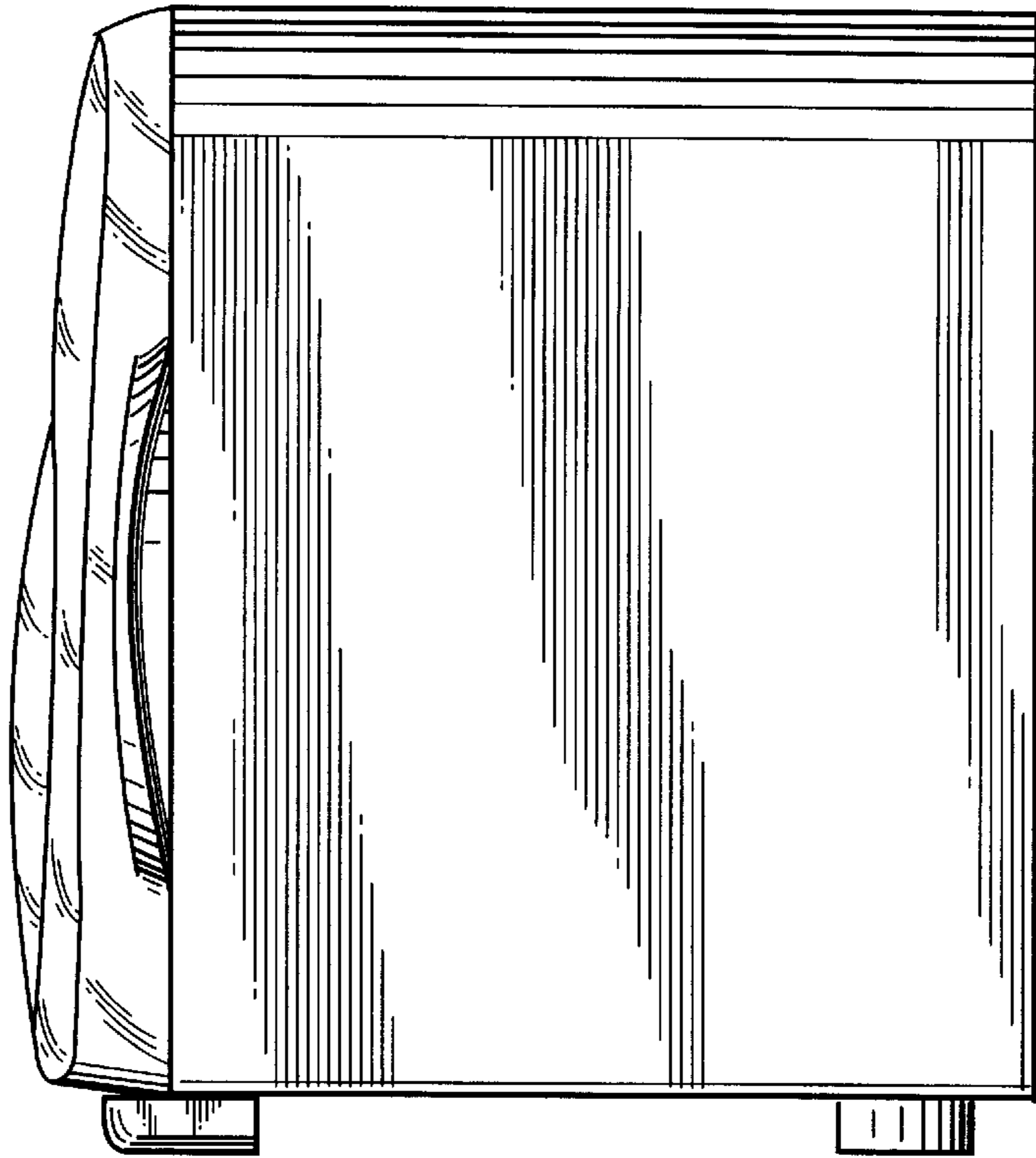

FIG. 5

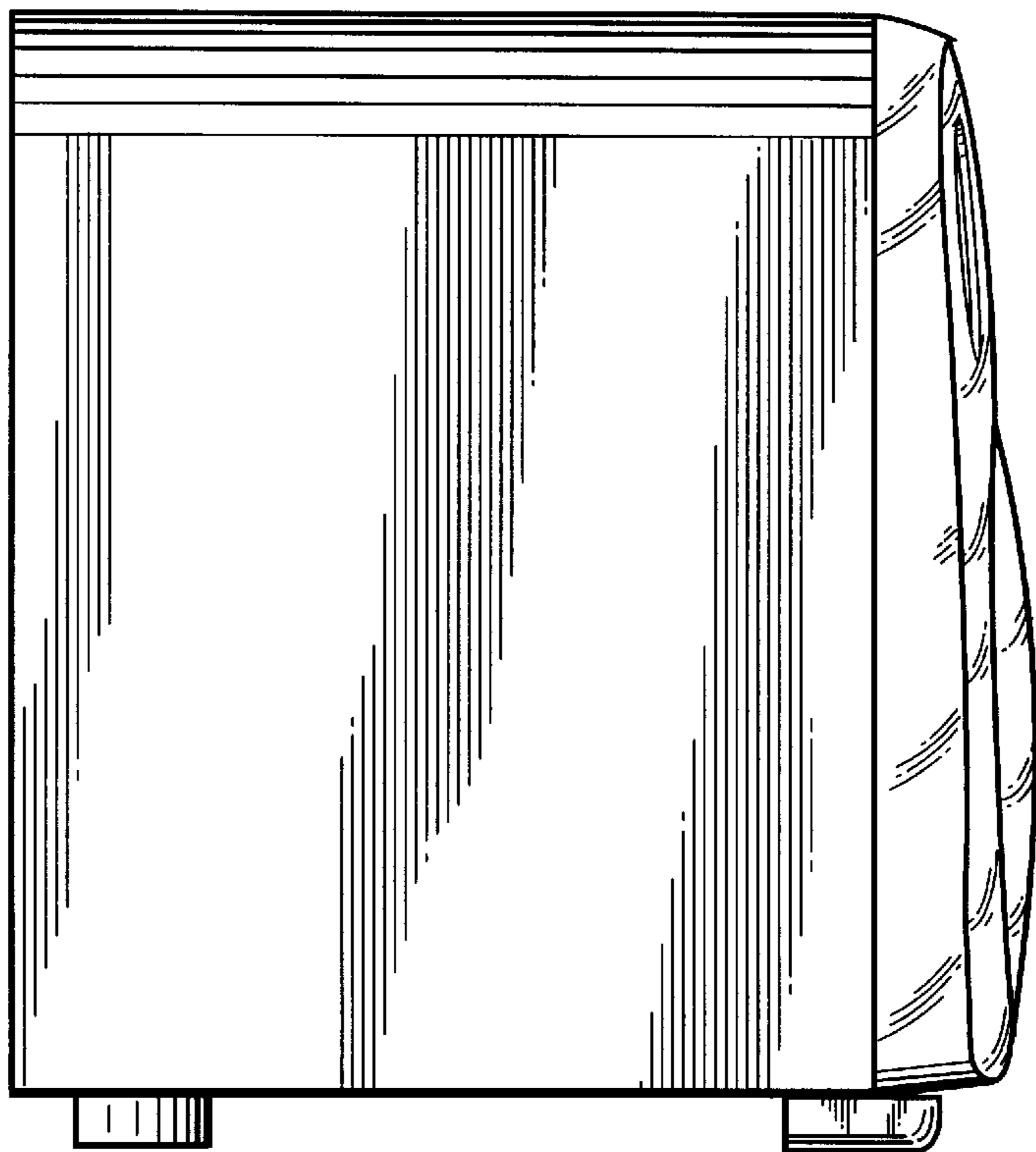

FIG. 6

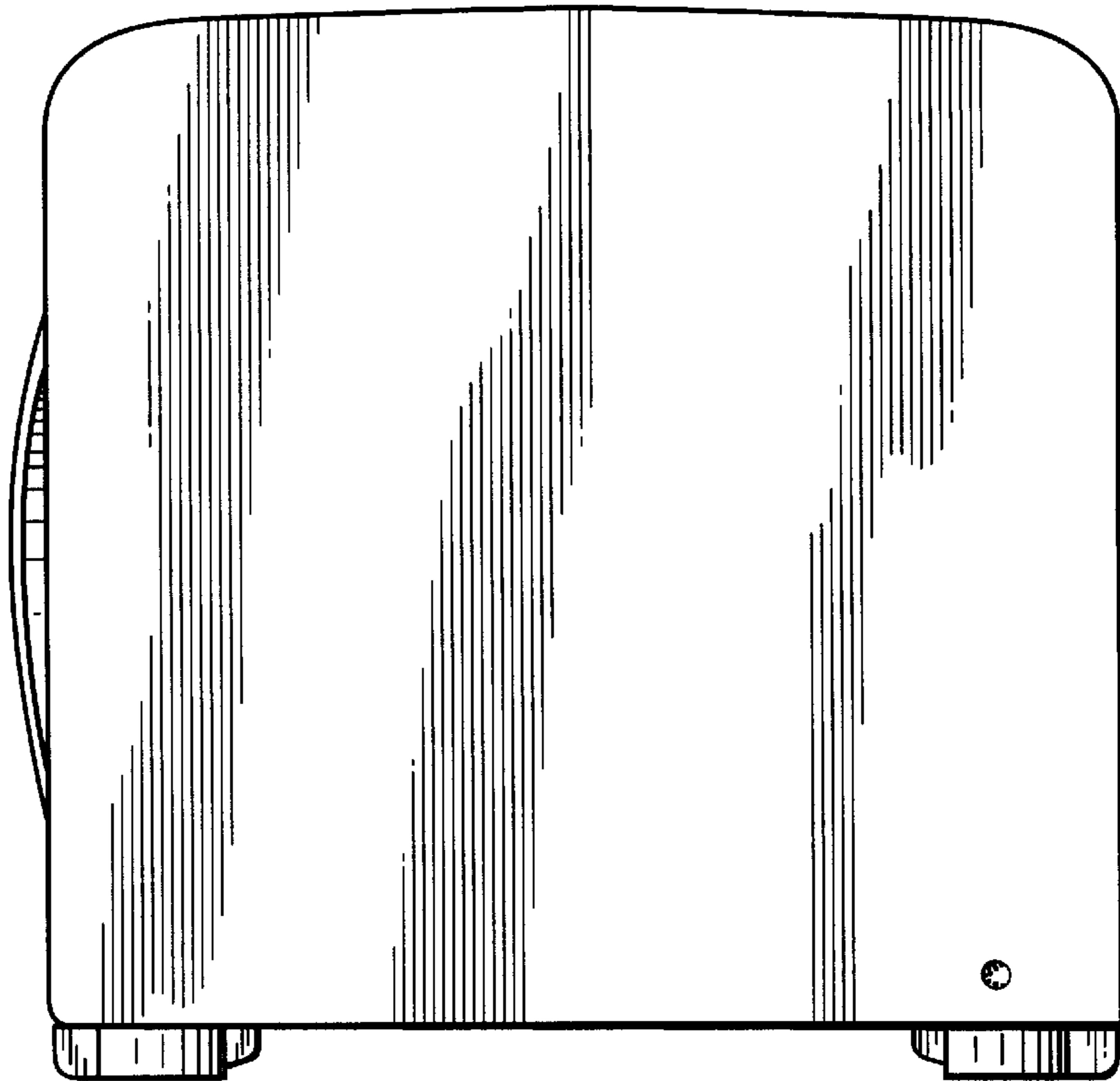

FIG. 7

