



US00D443019S

(12) **United States Design Patent**  
**Kang et al.**

(10) **Patent No.:** **US D443,019 S**

(45) **Date of Patent:** **\*\* May 29, 2001**

(54) **SPINNING REEL FOOT AND STEM**

FOREIGN PATENT DOCUMENTS

(75) Inventors: **Young Jue Kang**, Tulsa; **Rayford A. Cockerham**, Broken Arrow, both of OK (US); **Richard J. Robbins**, Sedgwick, KS (US)

2 050 781 6/1979 (GB) .

OTHER PUBLICATIONS

(73) Assignee: **Brunswick Corporation**, Lake Forest, IL (US)

*Bass Pro Shops*. Mater Catalog, 1999, p. 12, 15, 17-21, 24-27, 29-30, 32-33, 35, 37-41, 43, 54, 66, 81-82, 84, 85.  
*Browning Fishing*. Product catalog, 1999, p. 8-11, 21, 31.  
*Caleba's*. Master Catalog, Edition 1, Spring 1999, p. 11, 14-16, 18, 21-27, 43, 45, 47-49.  
*Quantum, Zebco, Martin*. Catalog, 1999, p. 13-19, 21, 33-34, 40, 45.

(\*\*) Term: **14 Years**

\* cited by examiner

(21) Appl. No.: **29/115,853**

(22) Filed: **Dec. 21, 1999**

*Primary Examiner*—Louis S. Zarfes

*Assistant Examiner*—Catherine R. Oliver

(51) **LOC (7) Cl.** ..... **22-05**

(52) **U.S. Cl.** ..... **D22/141**

(58) **Field of Search** ..... D22/137, 140,  
D22/141; 242/316, 224, 370, 223, 234,  
311, 322, 283; 43/19, 20, 21, 22

(74) *Attorney, Agent, or Firm*—Fellers, Snider, Blankenship, Bailey & Tippens, P.C.

(57) **CLAIM**

(56) **References Cited**

The ornamental design for a spinning reel foot and stem, as shown.

U.S. PATENT DOCUMENTS

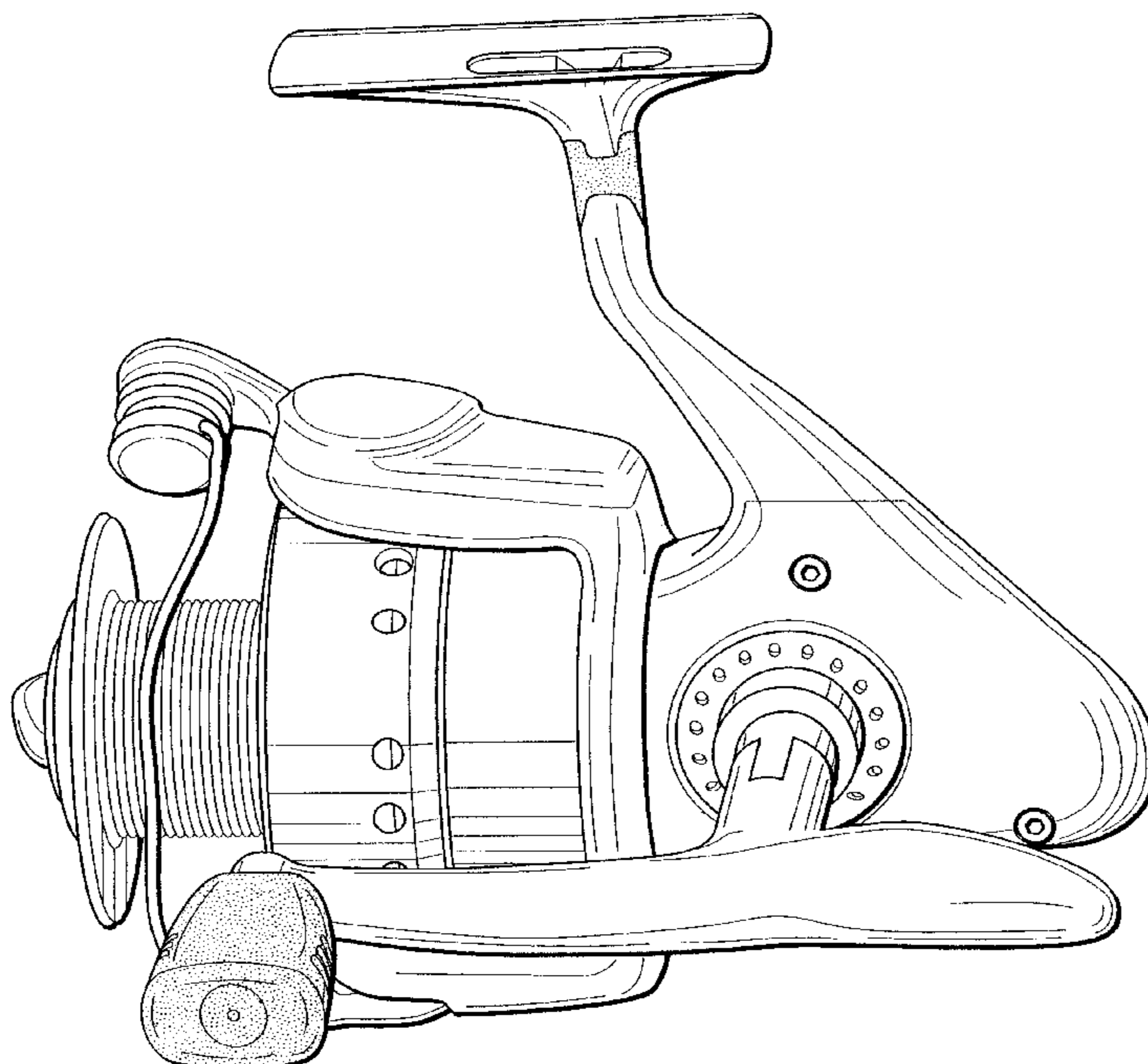
**DESCRIPTION**

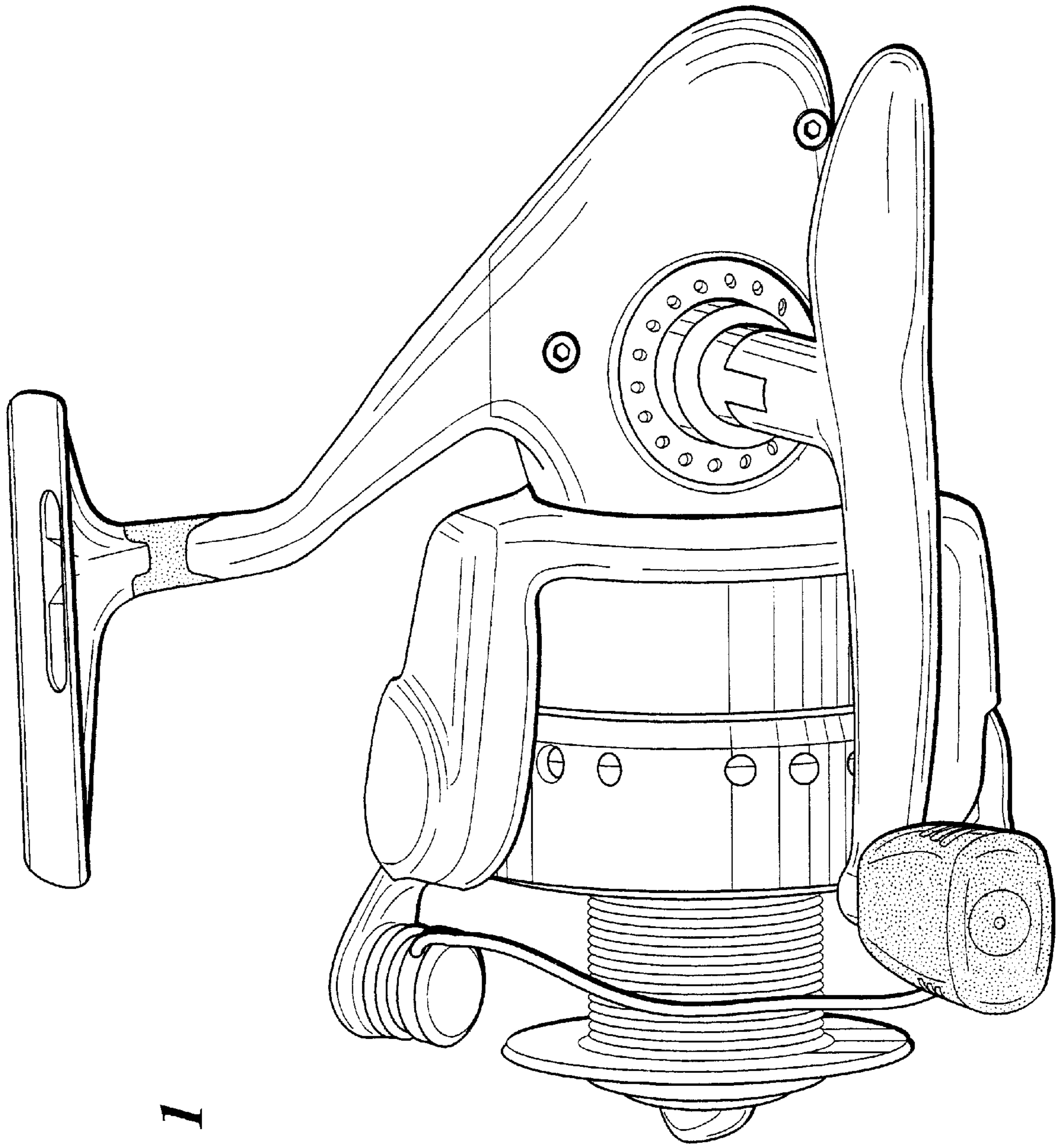
D. 269,798	*	7/1983	Fee et al.	.....	D22/141
D. 309,936		8/1990	Hiraishi et al.	.....	D22/141
D. 329,271		9/1992	Shiozaki	.....	D22/141
D. 353,183		12/1994	Kirby	.....	D22/141
D. 382,040		8/1997	Atherton et al.	.....	D22/141
D. 423,635	*	4/2000	Robbins	.....	D22/141
D. 424,657	*	5/2000	Kang et al.	.....	D22/141
4,108,392		8/1978	Masclat	.....	242/84.21
4,753,398		6/1988	Myojo	.....	242/84.2
4,830,306		5/1989	Tsunoda et al.	.....	242/84.2
4,905,399		3/1990	Hopps	.....	43/20
5,317,829		6/1994	Balkcom	.....	43/23
5,433,394	*	7/1995	Brozio	.....	242/283
5,904,000		5/1999	Ohmura	.....	43/22

FIG. 1 is a perspective view from palm side of a spinning reel foot and stem showing our new design; FIG. 2 is a front elevational view thereof; FIG. 3 is a right side elevational view thereof; FIG. 4 is a left side elevational view thereof; FIG. 5 is a rear elevational view thereof; FIG. 6 is a top plan view thereof; and, FIG. 7 is a bottom plan view thereof.

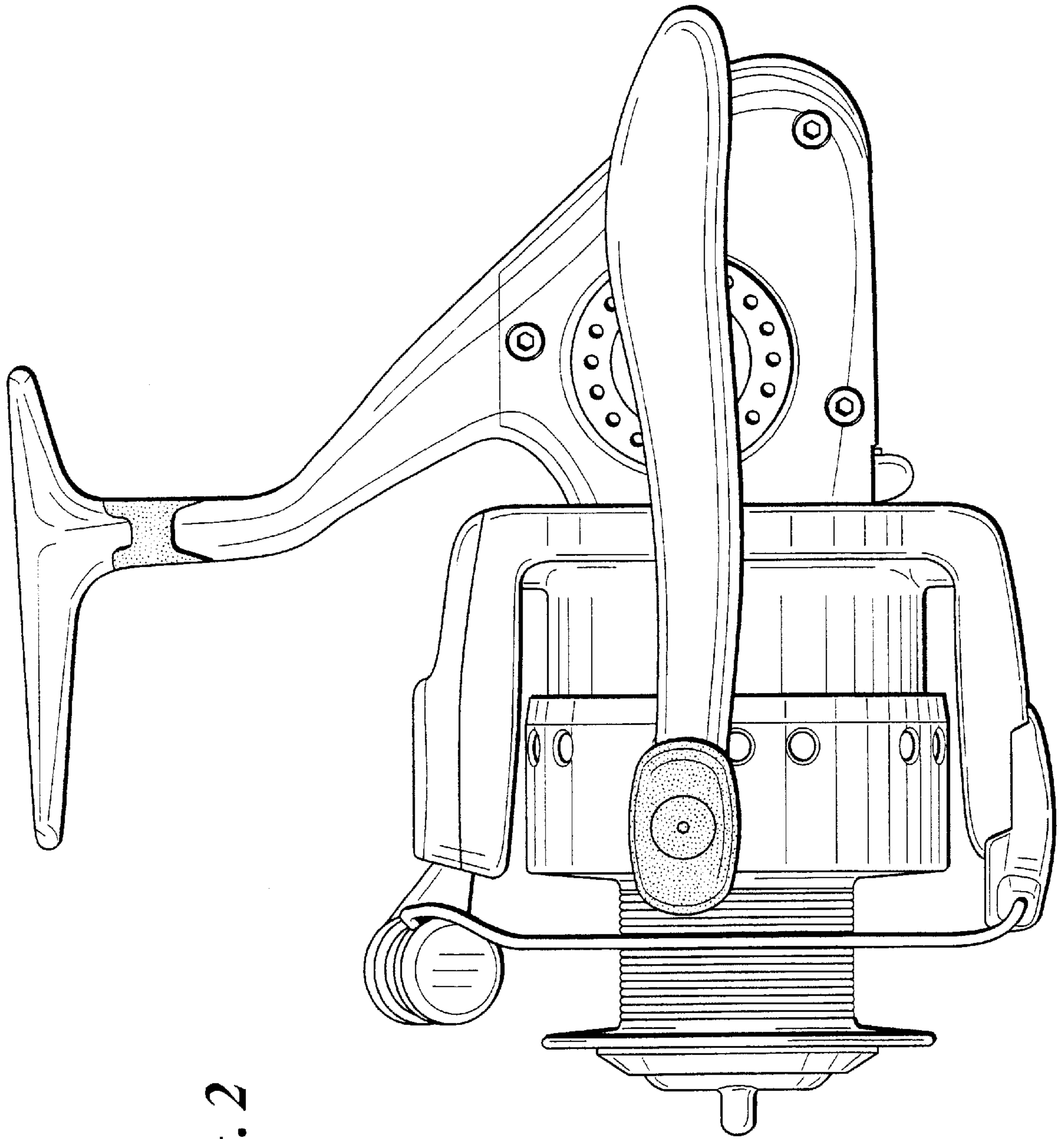
The broken line showing of environment in the drawings is for illustrative purposes only and forms no part of the claimed design.

**1 Claim, 7 Drawing Sheets**



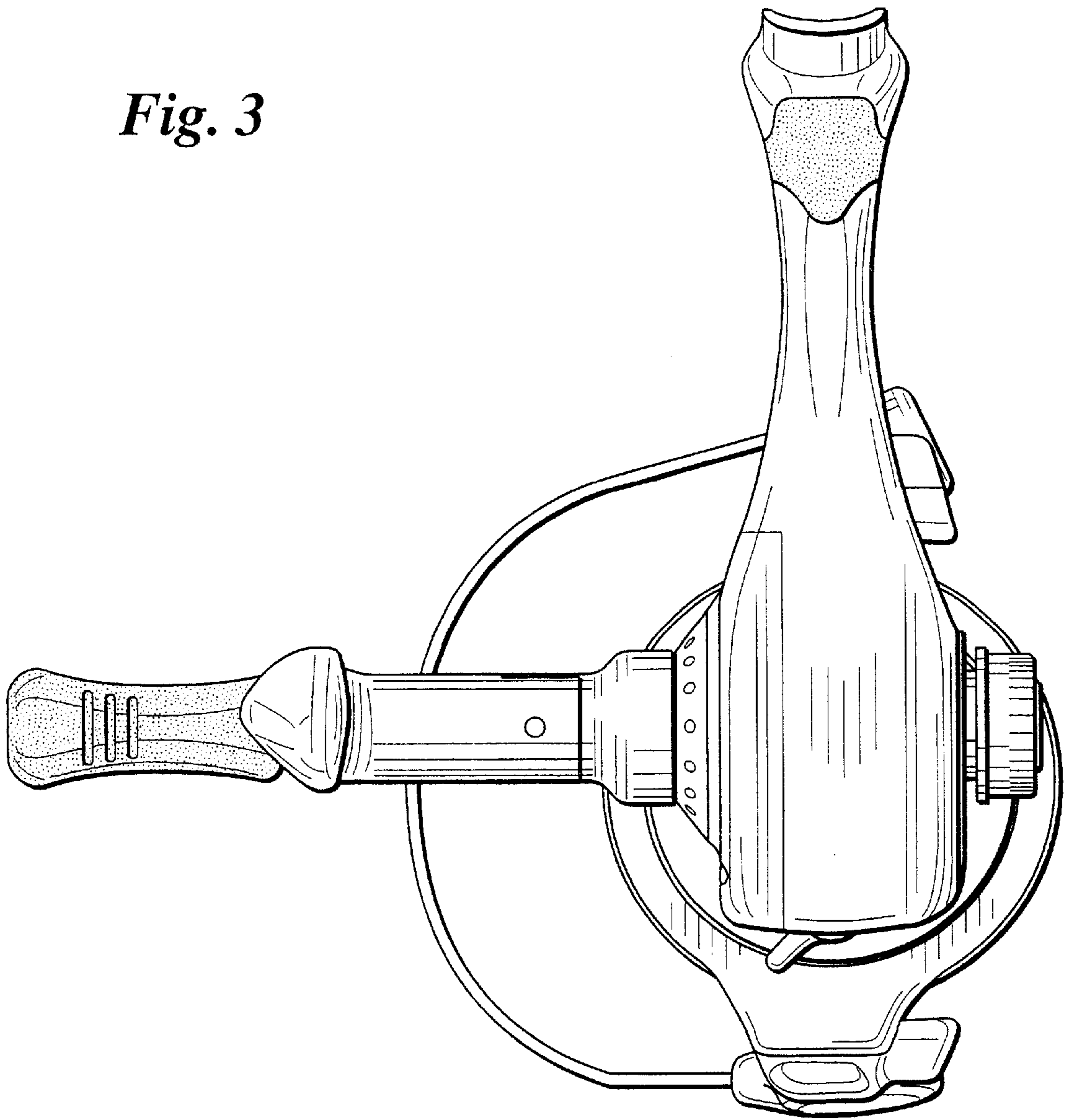


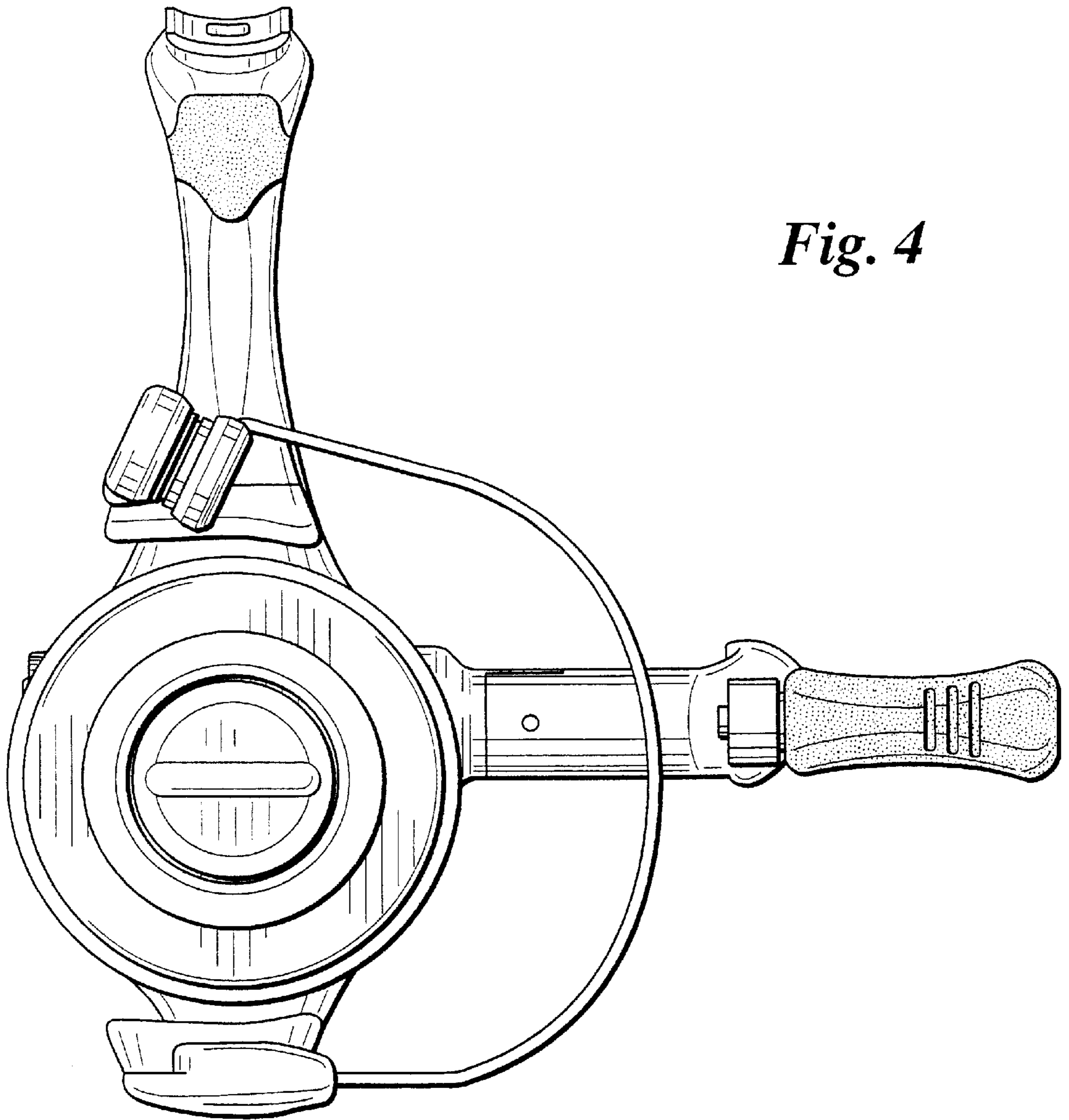
*Fig. 1*



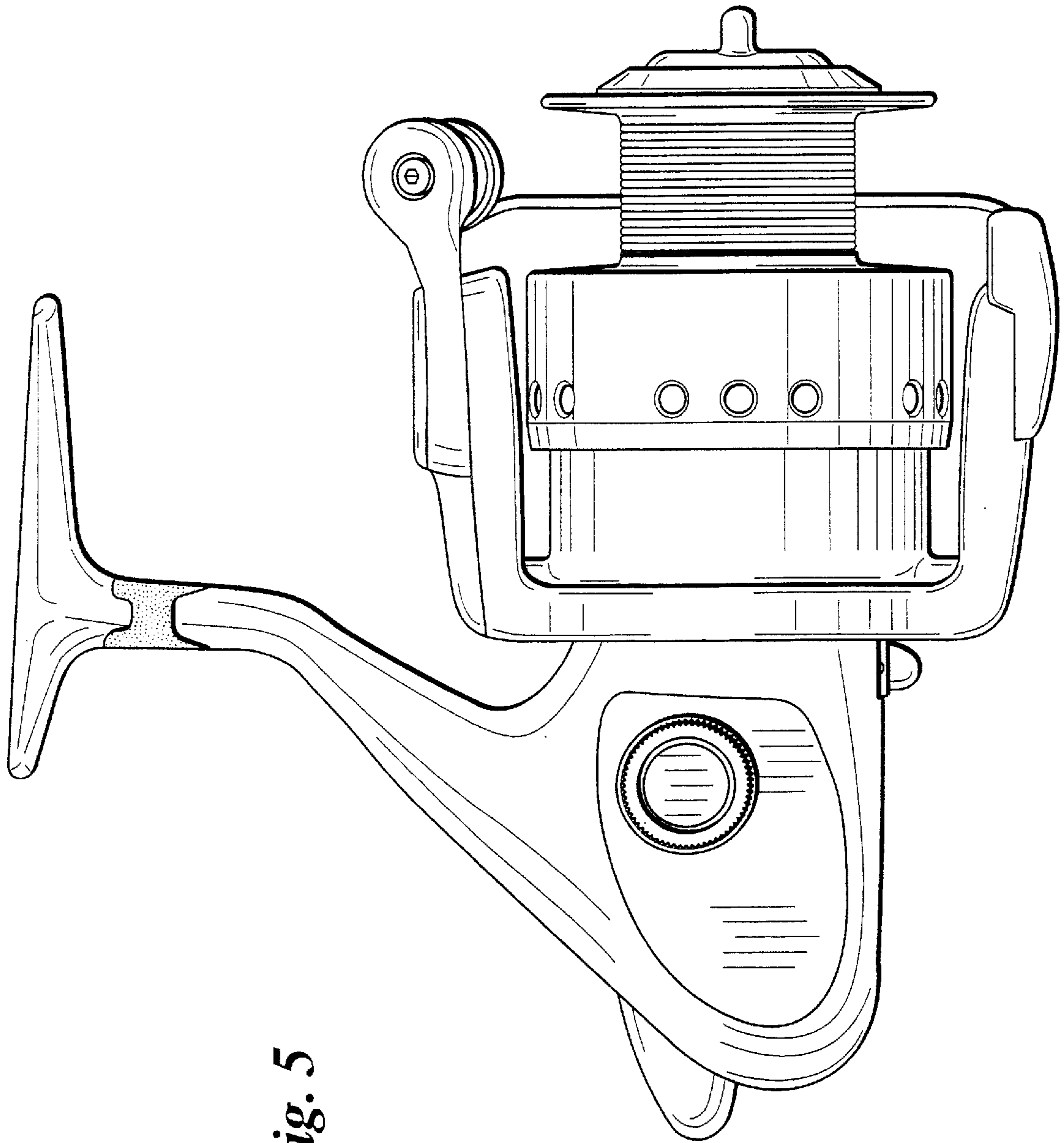
*Fig. 2*

*Fig. 3*

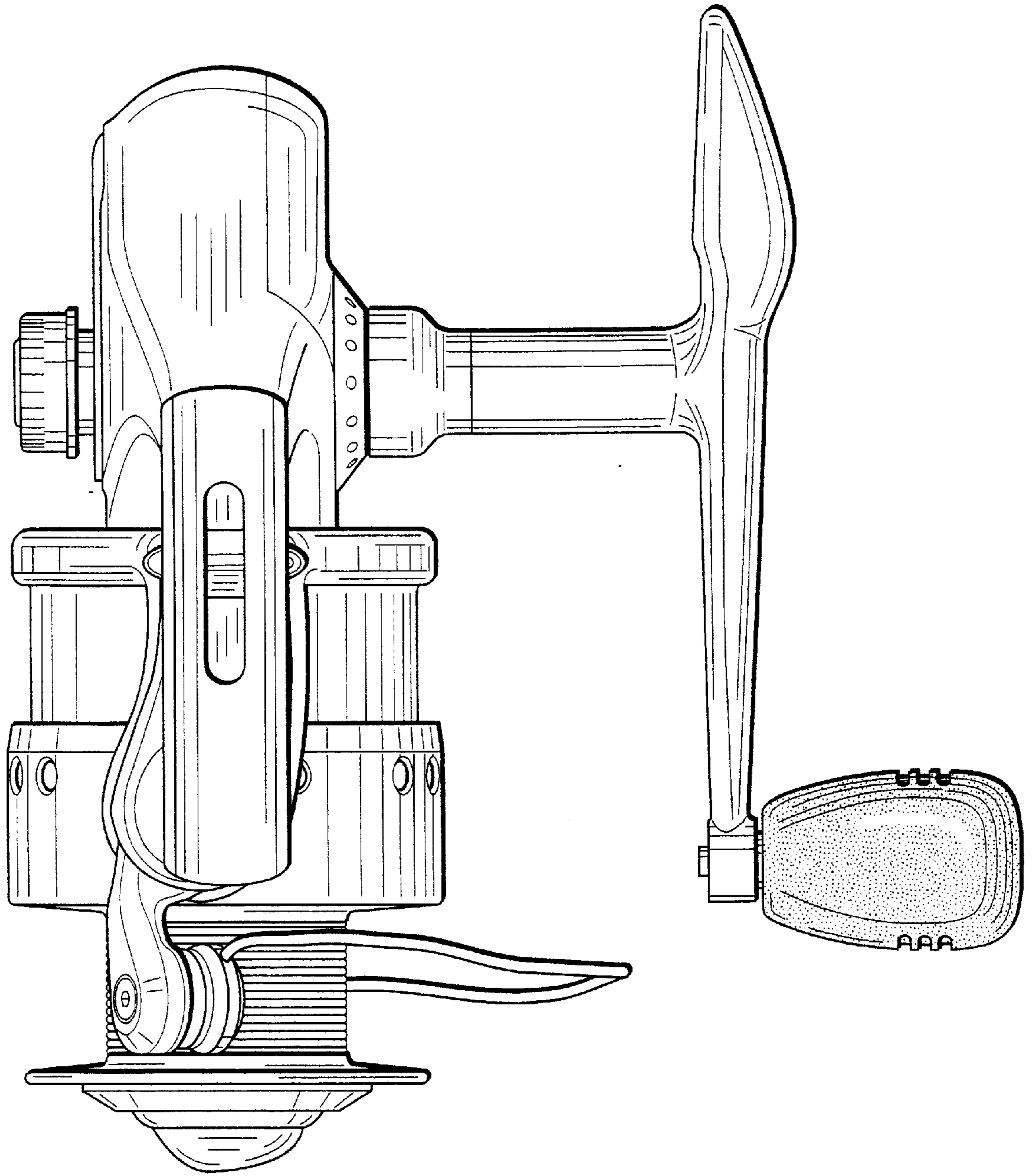




*Fig. 4*



*Fig. 5*



*Fig. 6*

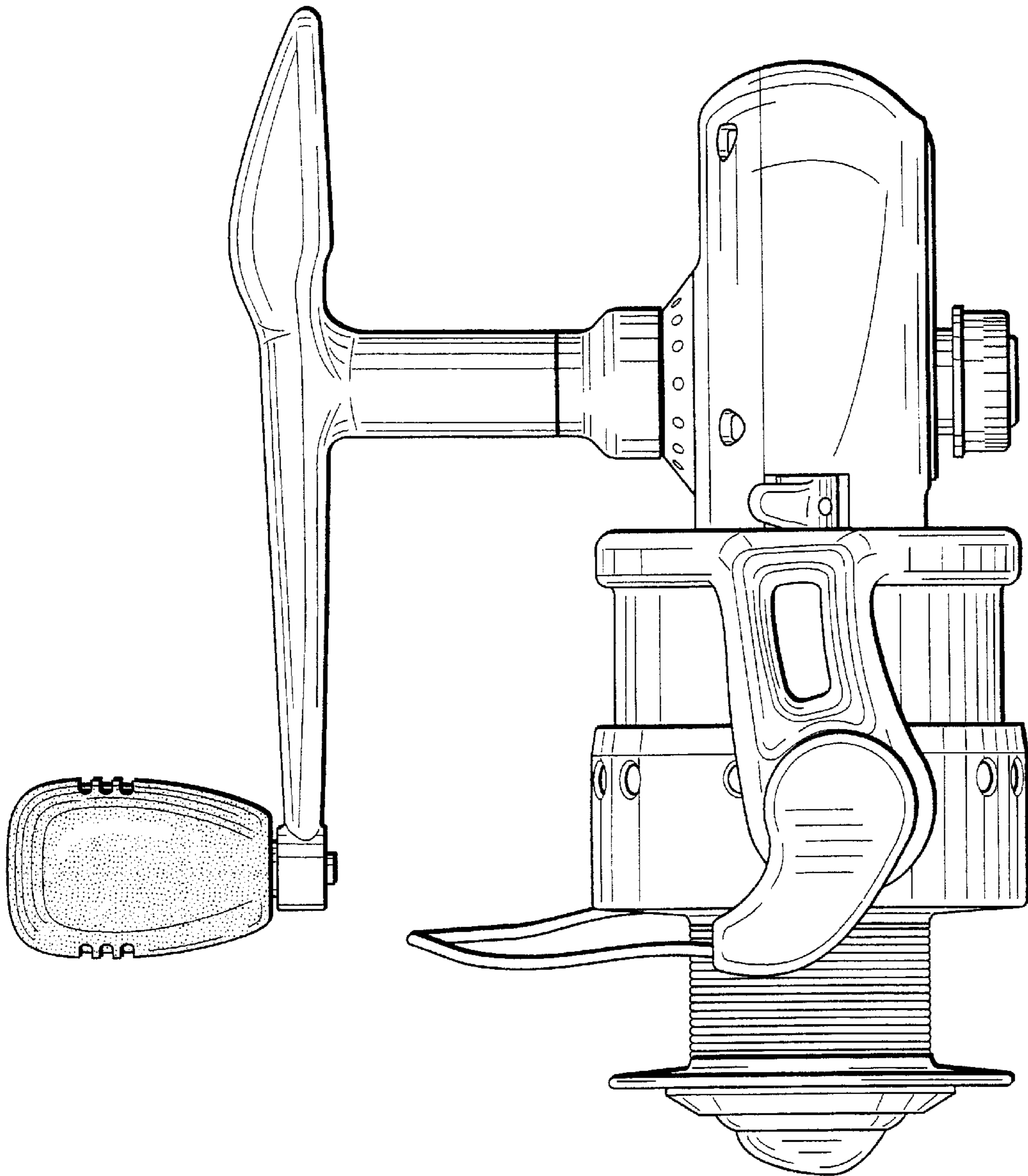


Figure 7



UNITED STATES PATENT AND TRADEMARK OFFICE  
**CERTIFICATE OF CORRECTION**

PATENT NO. : Des. 443,019 S  
DATED : May 29, 2001  
INVENTOR(S) : Kang et al.

Page 1 of 9


It is certified that error appears in the above-identified patent and that said Letters Patent is hereby corrected as shown below:

The Title page, showing an Illustrative figure, should be deleted and substitute therefore the attached title page.

Delete the drawing sheet(s) 1-7 of 7, and substitute therefore the drawing sheet(s) consisting of Fig(s) 1-7 as shown on the attached pages.

Signed and Sealed this

Twenty-seventh Day of May, 2003

A handwritten signature in black ink, appearing to read "James E. Rogan", with a thick horizontal line underneath it.

JAMES E. ROGAN  
*Director of the United States Patent and Trademark Office*

(12) **United States Design Patent** (10) **Patent No.:** **US D443,019 S**  
**Kang et al.** (45) **Date of Patent:** **\*\* May 29, 2001**

(54) **SPINNING REEL FOOT AND STEM**

(75) **Inventors:** **Young Jue Kang**, Tulsa; **Rayford A. Cockerham**, Broken Arrow, both of OK (US); **Richard J. Robbins**, Sedgwick, KS (US)

(73) **Assignee:** **Brunswick Corporation**, Lake Forest, IL (US)

(\*\*) **Term:** **14 Years**

(21) **Appl. No.:** **29/115,853**

(22) **Filed:** **Dec. 21, 1999**

(51) **LOC (7) Cl.** ..... **22-05**

(52) **U.S. Cl.** ..... **D22/141**

(58) **Field of Search** ..... **D22/137, 140, D22/141; 242/316, 224, 370, 223, 234, 311, 322, 283; 43/19, 20, 21, 22**

(56) **References Cited**

**U.S. PATENT DOCUMENTS**

D. 269,798 *	7/1983	Fee et al. ....	D22/141
D. 309,936	8/1990	Hiraishi et al. ....	D22/141
D. 329,271	9/1992	Shiozaki .....	D22/141
D. 353,183	12/1994	Kirby .....	D22/141
D. 382,040	8/1997	Atherton et al. ....	D22/141
D. 423,635 *	4/2000	Robbins .....	D22/141
D. 424,657 *	5/2000	Kang et al. ....	D22/141
4,108,392	8/1978	Masclet .....	242/84.21
4,753,398	6/1988	Myojo .....	242/84.2
4,830,306	5/1989	Tsunoda et al. ....	242/84.2
4,905,399	3/1990	Hopps .....	43/20
5,317,829	6/1994	Balkcom .....	43/23
5,433,394 *	7/1995	Brozio .....	242/283
5,904,000	5/1999	Ohmura .....	43/22

**FOREIGN PATENT DOCUMENTS**

2 050 781 6/1979 (GB) .

**OTHER PUBLICATIONS**

*Bass Pro Shops*. Mater Catalog, 1999, p. 12, 15, 17-21, 24-27, 29-30, 32-33, 35, 37-41, 43, 54, 66, 81-82, 84, 85.  
*Browning Fishing*. Product catalog, 1999, p. 8-11, 21, 31.  
*Caleba's*. Master Catalog, Edition 1, Spring 1999, p. 11, 14-16, 18, 21-27, 43, 45, 47-49.  
*Quantum, Zebco, Martin*. Catalog, 1999, p. 13-19, 21, 33-34, 40, 45.

\* cited by examiner

*Primary Examiner*—Louis S. Zarfes

*Assistant Examiner*—Catherine R. Oliver

(74) *Attorney, Agent, or Firm*—Fellers, Snider, Blankenship, Bailey & Tippens, P.C.

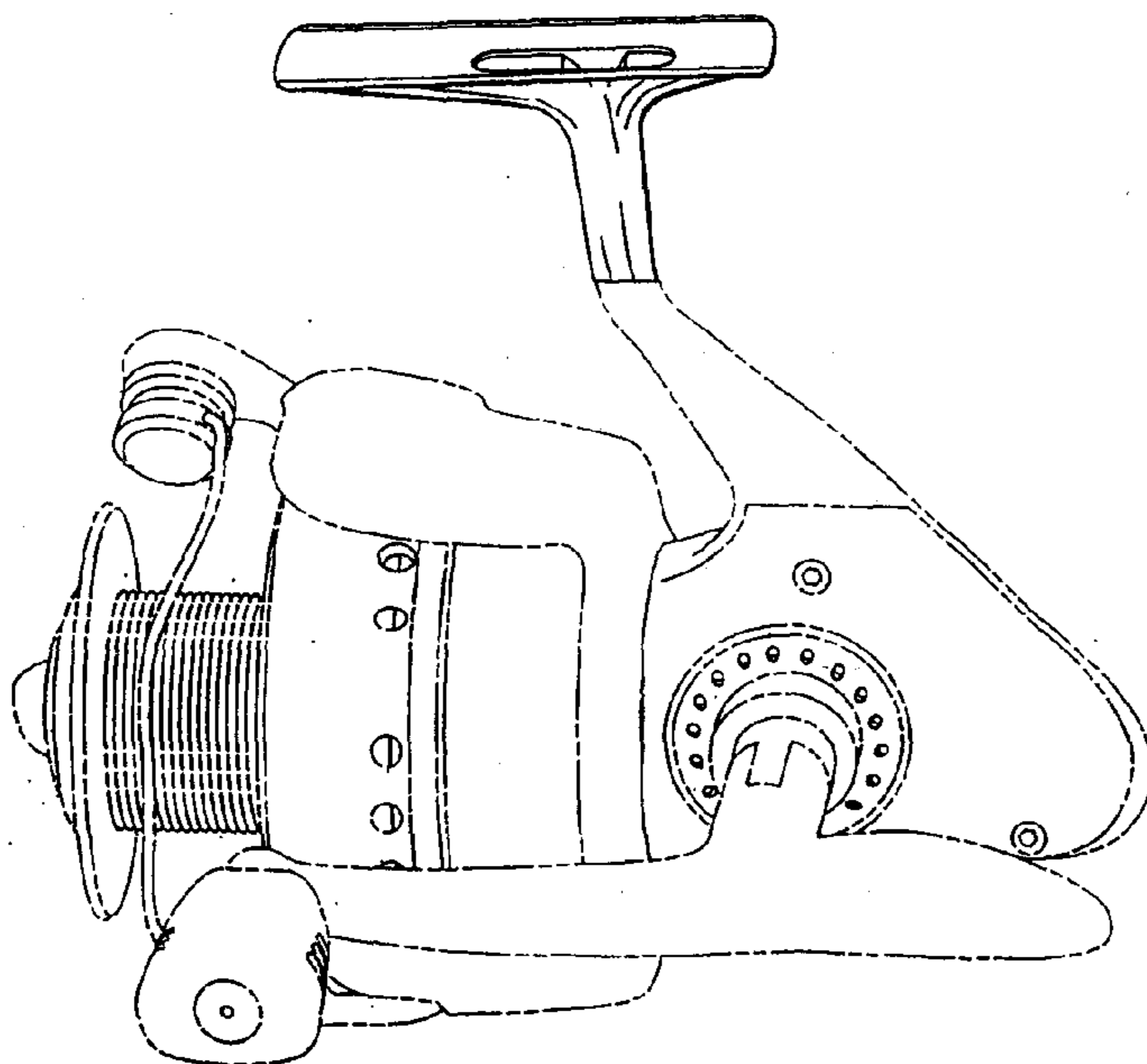
(57) **CLAIM**

The ornamental design for a spinning reel foot and stem, as shown.

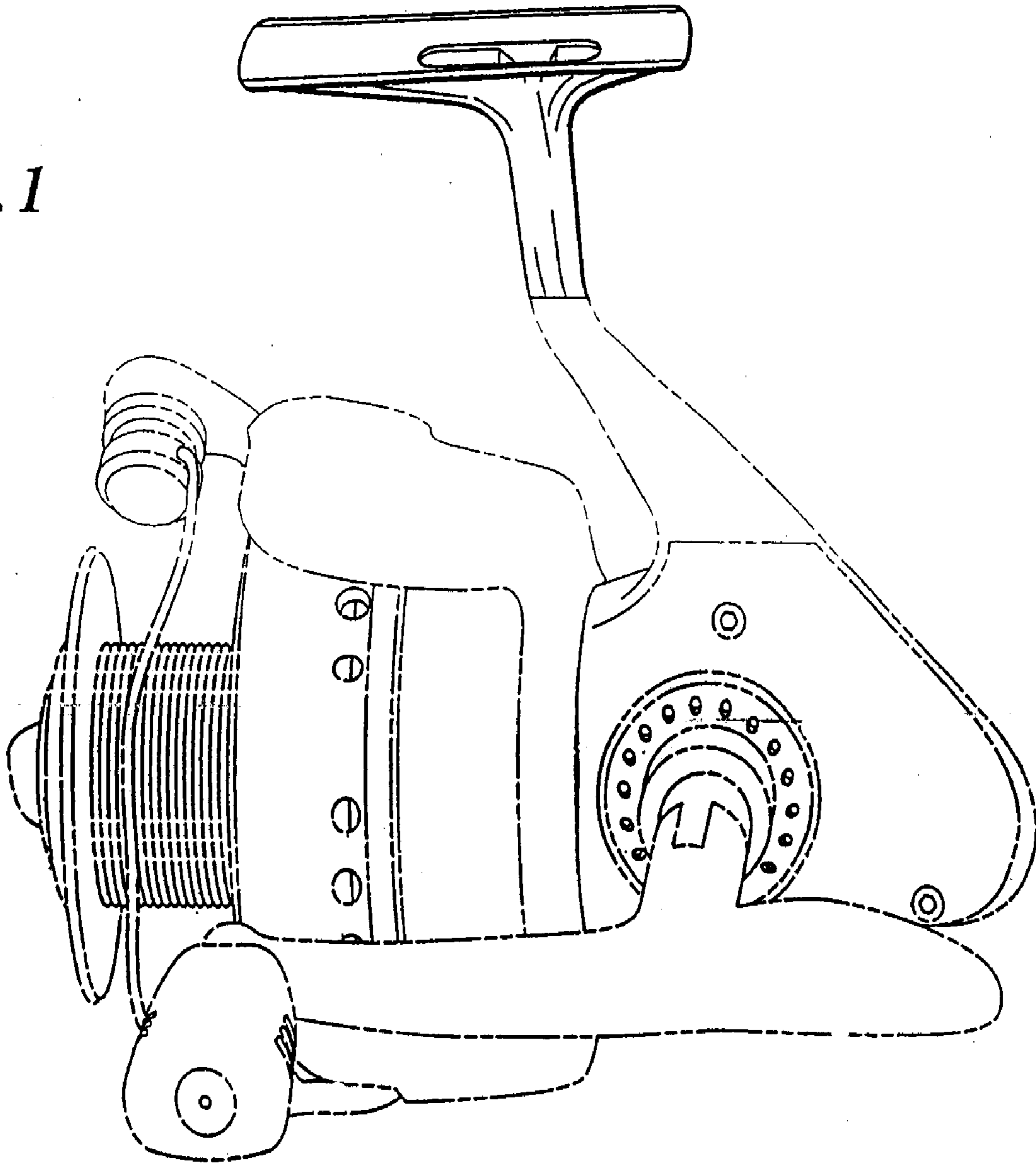
**DESCRIPTION**

FIG. 1 is a perspective view from palm side of a spinning reel foot and stem showing our new design; FIG. 2 is a front elevational view thereof; FIG. 3 is a right side elevational view thereof; FIG. 4 is a left side elevational view thereof; FIG. 5 is a rear elevational view thereof; FIG. 6 is a top plan view thereof; and, FIG. 7 is a bottom plan view thereof. The broken line showing of environment in the drawings is for illustrative purposes only and forms no part of the claimed design.

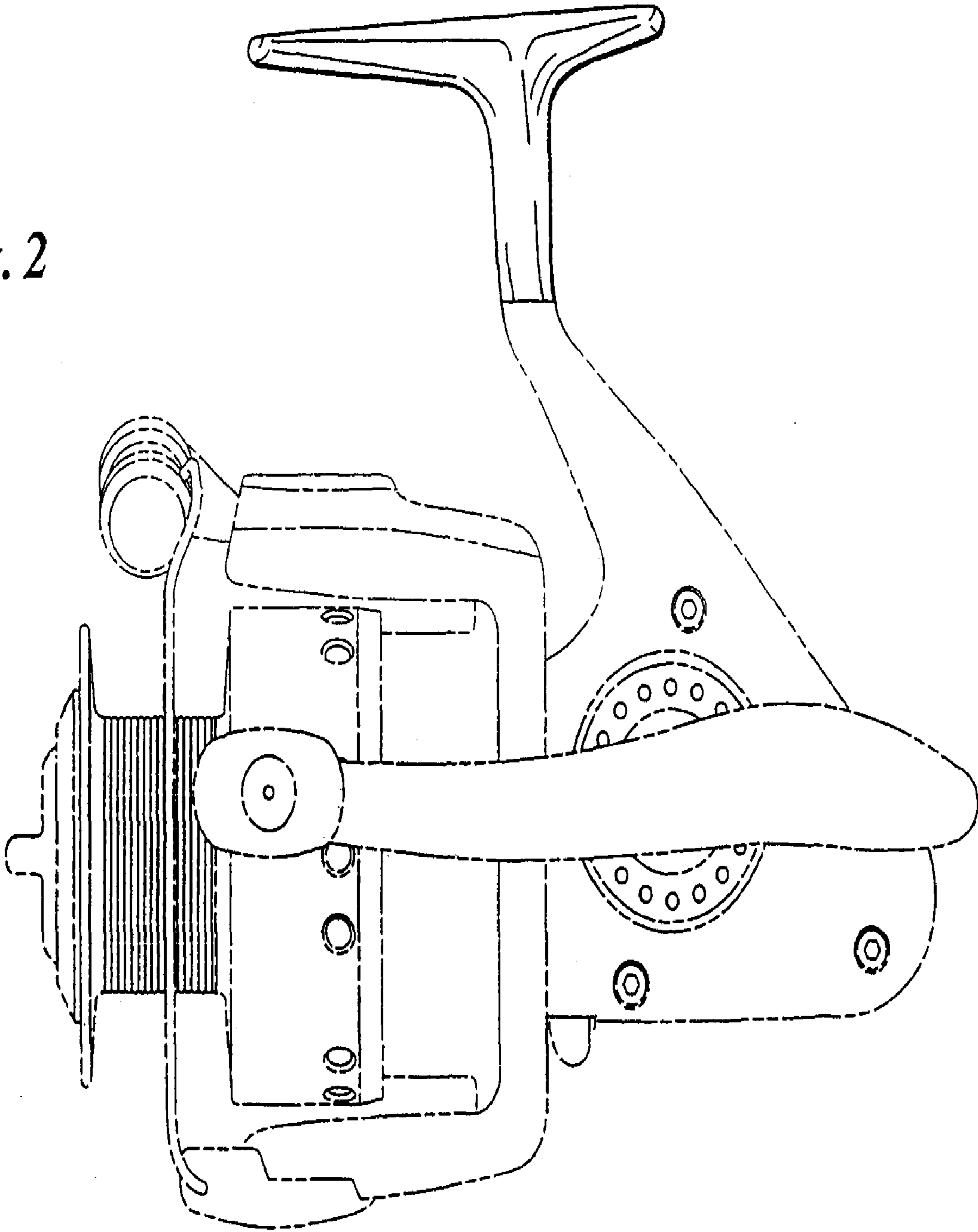
1 Claim, 7 Drawing Sheets



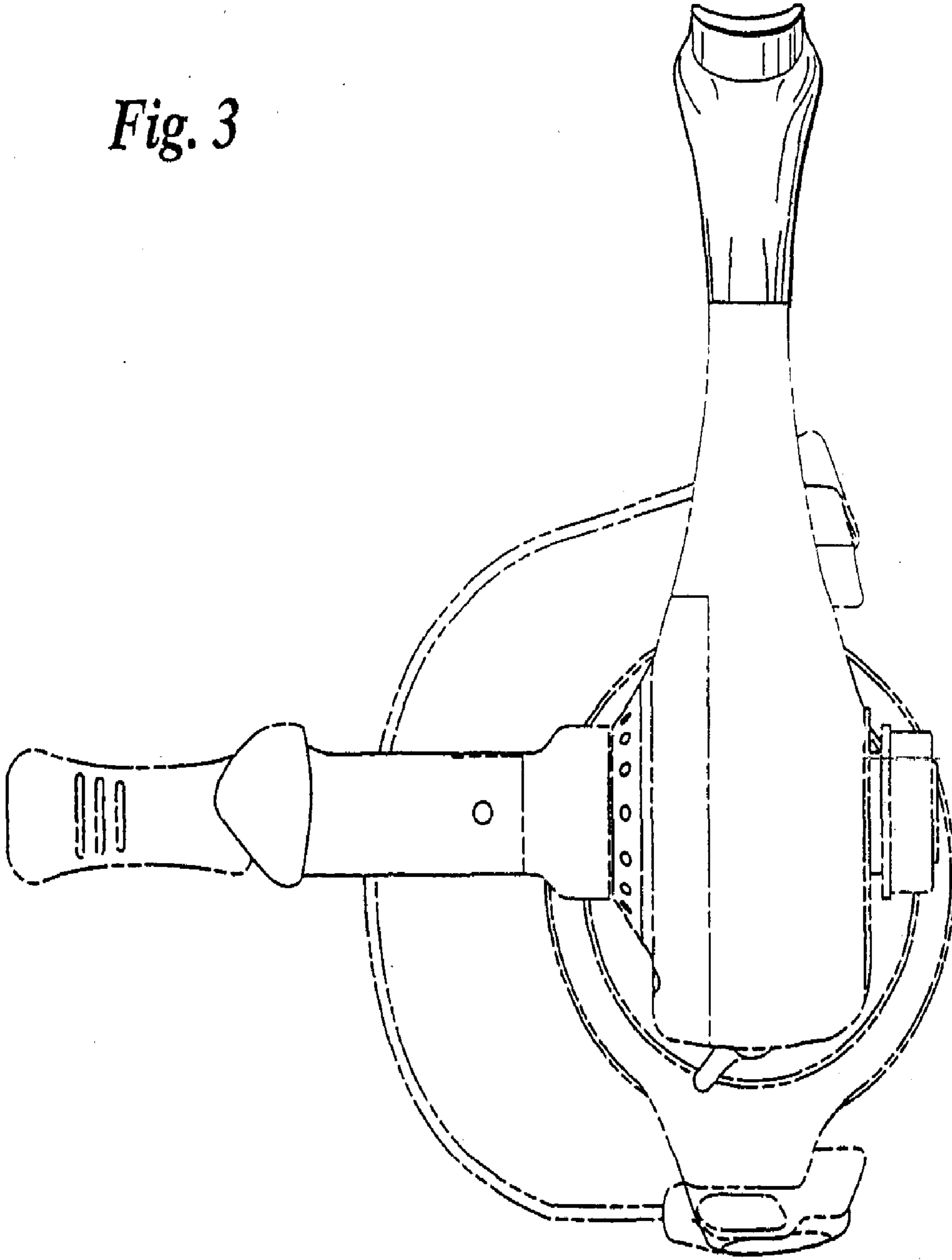
*Fig. 1*

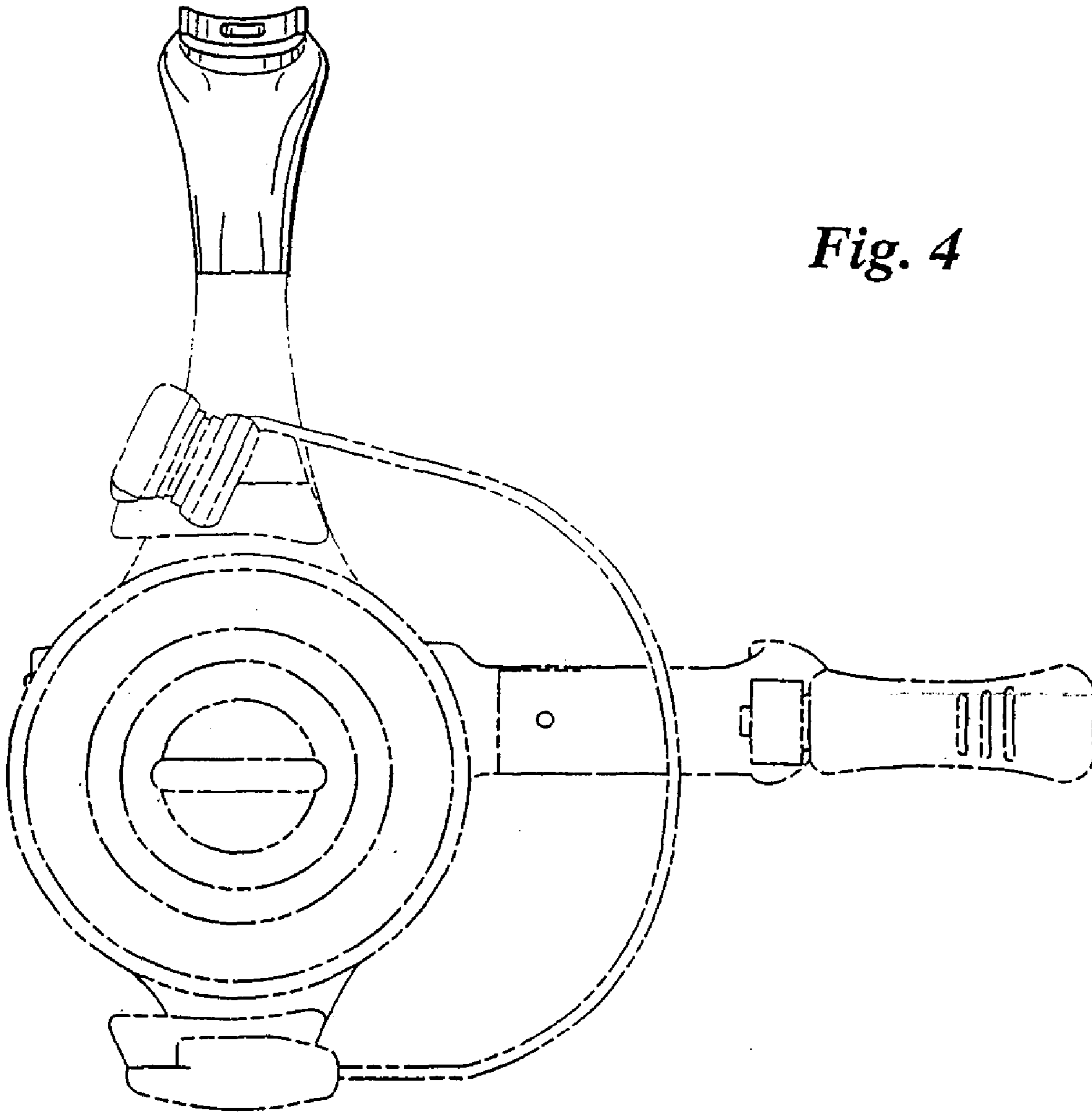


*Fig. 2*



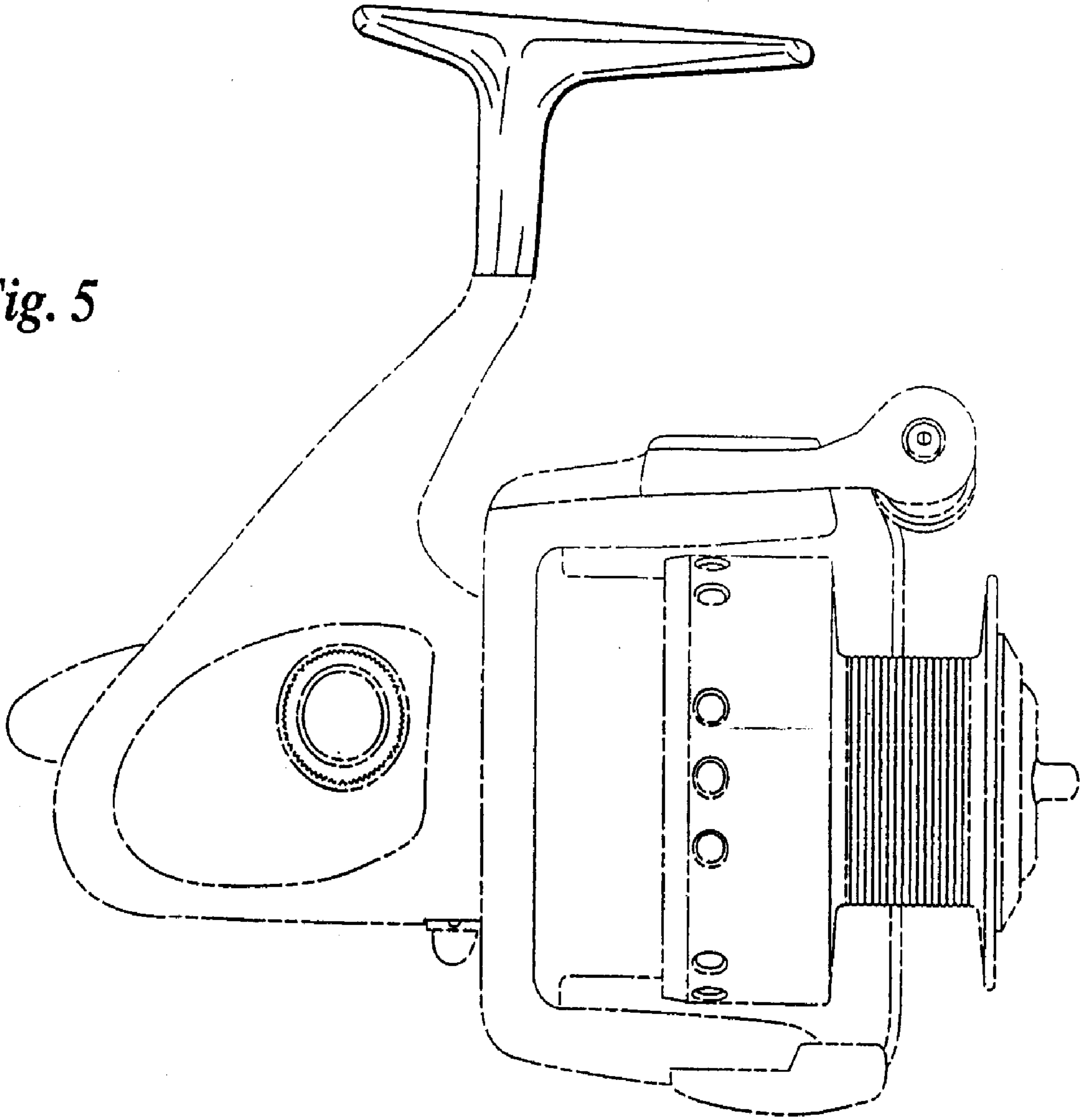
*Fig. 3*

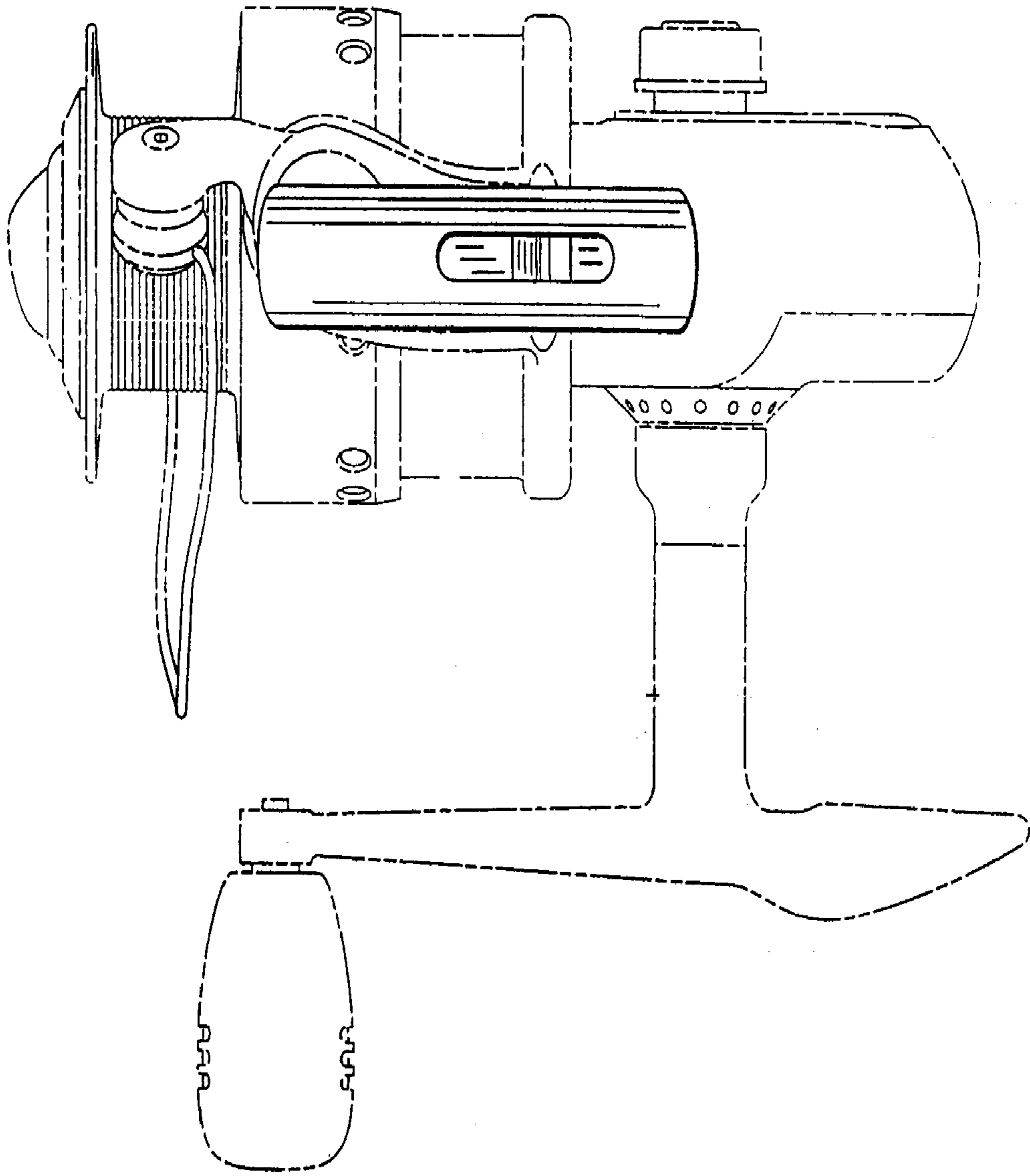




*Fig. 4*

***Fig. 5***





*Fig. 6*



**U.S. Patent**

**May 29, 2001**

**Sheet 7 of 7**

**D443,019 S**

